

# The Design of Rolling Bearing Mountings

FAG

Rolling Bearings

FAG Bearings Limited

Publ. No. WL 00 200/5 EC

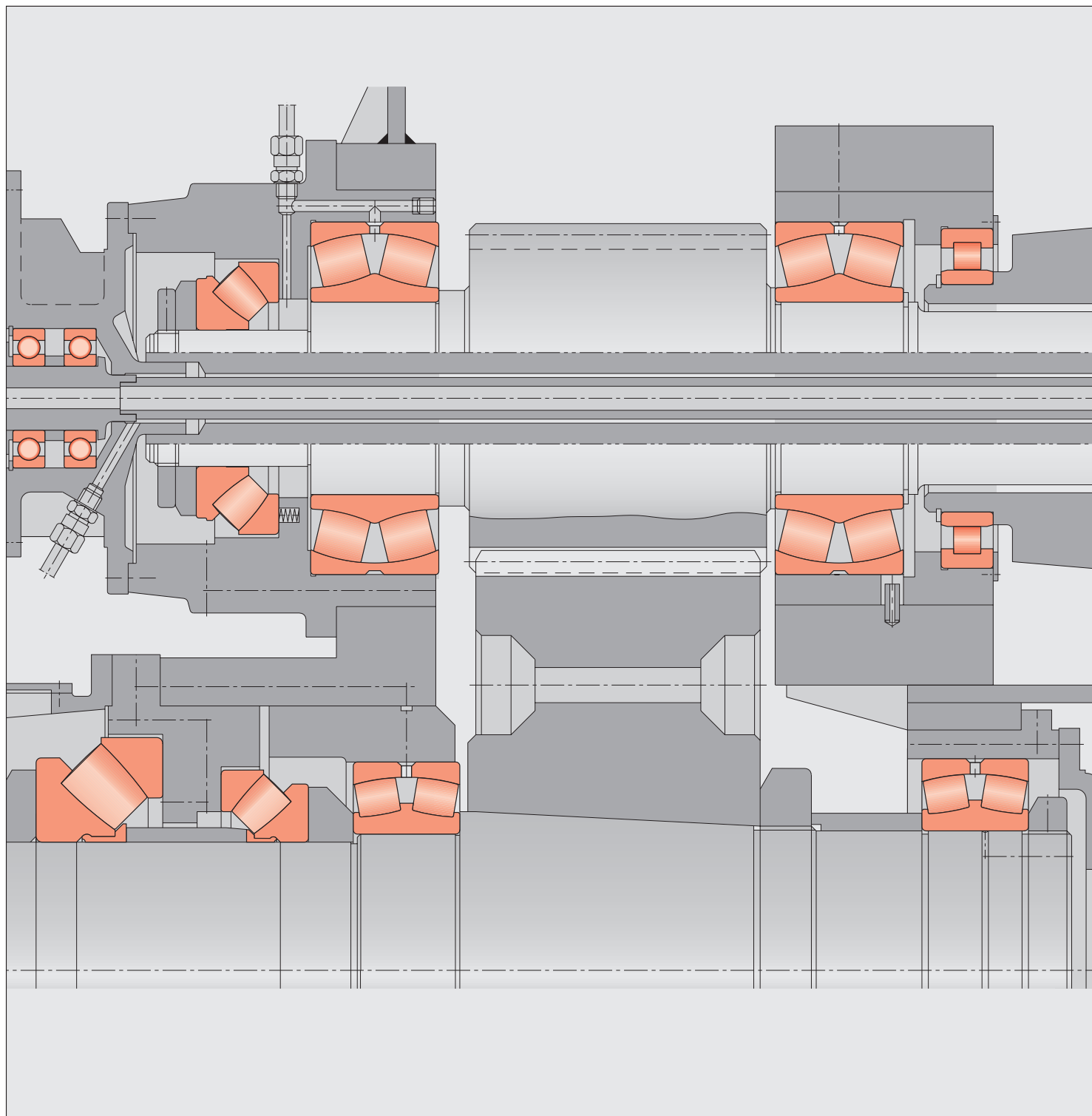

---

# The Design of Rolling Bearing Mountings

Design Examples covering  
Machines, Vehicles and Equipment

Publ. No. WL 00 200/5 EA

**FAG OEM und Handel AG**

A company of the FAG Kugelfischer Group

Postfach 1260 · D-97419 Schweinfurt

Telephone (0 97 21) 91-0 · Telefax (0 97 21) 91 34 35

Telex 67345-0 fag d

---

---

# Preface

---

This publication presents design examples covering various machines, vehicles and equipment having one thing in common: rolling bearings.

For this reason the brief texts concentrate on the rolling bearing aspects of the applications. The operation of the machine allows conclusions to be drawn about the operating conditions which dictate the bearing type and design, the size and arrangement, fits, lubrication and sealing.

Important rolling bearing engineering terms are printed in italics. At the end of this publication they are summarized and explained in a glossary of terms, some supplemented by illustrations.

Example Title	Page	Example Title	Page
<b>PRIME MOTORS, ELECTRIC MOTORS</b>		<b>MOTOR VEHICLES</b>	
1 Traction motor for electric standard-gauge locomotives . . . . .	6	<b>Automotive gearboxes</b> . . . . .	48
2 Traction motor for electric commuter trains . . . . .	8	32 Passenger car transmission . . . . .	50
3 Three-phase current standard motor . . . . .	10	33 Manual gearbox for trucks . . . . .	51
4 Electric motor for domestic appliances . . . . .	11	<b>Automotive differentials</b> . . . . .	52
5 Drum of a domestic washing machine . . . . .	12	34 Final drive of a passenger car . . . . .	53
6 Vertical-pump motor . . . . .	14	<b>Automotive wheels</b> . . . . .	54
7 Mine fan motor . . . . .	16	35 Driven and steered front wheel of a front drive passenger car . . . . .	55
<b>POWER ENGINEERING</b>		36 Driven and non-steered rear wheel of a rear drive passenger car . . . . .	56
8 Rotor of a wind energy plant . . . . .	18	37 Driven and non-steered rear wheel of a rear drive truck . . . . .	57
<b>METALWORKING MACHINES</b>		38 Steering king pin of a truck . . . . .	58
<b>Work spindles of machine tools</b> . . . . .	20	39 Shock absorbing strut for the front axle of a car . . . . .	59
9 Drilling and milling spindle . . . . .	21	<b>Other automotive bearing arrangements</b>	
10 NC-lathe main spindle . . . . .	22	40 Water pump for passenger car and truck engines . . . . .	60
11 CNC-lathe main spindle . . . . .	23	41 Belt tensioner for passenger car engines . . . . .	61
12 Plunge drilling spindle . . . . .	24	<b>RAIL VEHICLES</b>	
13 High-speed motor milling spindle . . . . .	25	<b>Wheelsets</b>	
14 Motor spindle of a lathe . . . . .	26	42 Axle box roller bearings of an Intercity train carriage . . . . .	62
15 Vertical high-speed milling spindle . . . . .	27	43-44 UIC axle box roller bearings for freight cars . . . . .	64
16 Bore grinding spindle . . . . .	28	45 Axle box roller bearings of series 120's three-phase current locomotive . . . . .	66
17 External cylindrical grinding spindle . . . . .	29	46 Axle box roller bearings for an ICE driving unit . . . . .	67
18 Surface grinding spindle . . . . .	30	47 Axle box roller bearings for the Channel tunnel's freight engine, class 92 . . . . .	68
<b>Other bearing arrangements</b>		48 Axle box roller bearings for an underground train . . . . .	70
19 Rotary table of a vertical lathe . . . . .	31	49 Axle box roller bearings for a light rail vehicle . . . . .	71
20 Tailstock spindle . . . . .	32	50 Axle box roller bearings according to A.A.R. standard and modified types . . . . .	72
21 Rough-turning lathe for round bars and pipes . . . . .	33	51 Kiln trucks for sand lime brick works . . . . .	73
22 Flywheel of a car body press . . . . .	34	<b>Drives</b>	
<b>MACHINERY FOR WORKING AND PROCESSING NON-METALLIC MATERIALS</b>		52 Universal quill drive for threephase current locomotives of series 120 . . . . .	74
23 Vertical wood milling spindle . . . . .	36	53 Suspension bearing arrangement for electric goods train locomotive . . . . .	75
24 Double-shaft circular saw . . . . .	37	54 Spur gear transmission for the underground or subway . . . . .	76
25 Rolls for a plastic calender . . . . .	38	55 Bevel gear transmission for city trains . . . . .	78
<b>STATIONARY GEARS</b>			
26 Infinitely variable gear . . . . .	40		
27 Spur gear transmission for a reversing rolling stand . . . . .	41		
28 Marine reduction gear . . . . .	42		
29 Bevel gear – spur gear transmission . . . . .	45		
30 Double-step spur gear . . . . .	46		
31 Worm gear pair . . . . .	47		

# Contents

Example Title	Page	Example Title	Page
<b>SHIPBUILDING</b>		<b>Excavators and bucket elevators</b>	
<b>Rudder shafts</b> .....	79	87 Bucket wheel shaft of a bucket wheel excavator .....	124
56-57 Spherical roller bearings as rudder shaft bearings .....	80	88 Bottom sprocket of a bucket chain dredger .....	125
58-59 Spherical roller thrust bearings as rudder carriers .....	81	89 Drive unit of a finished-goods elevator .	126
60 Spade-type rudder .....	82		
<b>Ship shafts</b>		<b>CONSTRUCTION MACHINERY</b>	
61-62 Ship shaft bearings and stern tube bearings .....	84	90 Driving axle of a construction machine .	127
63-64 Ship shaft thrust blocks .....	86	91 Vibrating road roller .....	128
<b>PAPER MACHINES</b> .....		<b>RAW MATERIAL PROCESSING</b>	
65 Refiners .....	89	<b>Crushers and mills</b>	
66 Suction rolls .....	90	92 Double toggle jaw crusher .....	130
67 Central press rolls .....	92	93 Hammer mill .....	131
68 Dryer rolls .....	93	94 Double-shaft hammer crusher .....	132
69 Guide rolls .....	94	95 Ball tube mill .....	134
70 Calender thermo rolls .....	96	96 Support roller of a rotary kiln .....	136
71 Anti-deflection rolls .....	98		
72 Pre-reading rolls .....	100	<b>Vibrating machines</b> .....	
	101	97 Two-bearing screen with circle throw ...	139
<b>LIFTING AND CONVEYING EQUIPMENT</b>		98 Two-bearing screen with straight-line motion .....	140
<b>Aerial ropeways, rope sheaves</b>		99 Four-bearing screen .....	142
73 Run wheel of a material ropeway .....	102	100 Vibrator motor .....	143
74 Rope return sheaves of passenger ropeway .....	104		
75 Rope sheave (underground mining) ....	106	<b>STEEL MILL AND ROLLING MILL EQUIPMENT</b>	
76 Rope sheave of a pulley block .....	108	101-103 Large-capacity converters .....	144
<b>Cranes, lift trucks</b>		104 Roll bearings of a non-reversing four-high cold rolling stand for aluminium ..	146
77 Crane pillar mounting with a spherical roller thrust bearing .....	110	105 Work rolls for the finishing section of a four-high hot wide strip mill .....	148
78 Crane pillar mounting with a spherical roller thrust bearing and a spherical roller bearing .....	111	106 Roll mountings of a two-high ingot slab stand or ingot billet stand .....	149
79 Roller track assembly .....	112	107 Combined reduction and cogging wheel gear of a billet mill .....	150
80 Crane run wheel .....	114	108 Work rolls of a section mill .....	152
81 Crane hook .....	116	109 Two-high rolls of a dressing stand for copper and brass bands .....	154
82 Mast guidance bearings of a fork lift truck .....	117	110 Straightening rolls of a rail straightener .	156
<b>Belt conveyors</b>		<b>AGRICULTURAL MACHINERY · FOOD INDUSTRY</b>	
83 Head pulley of a belt conveyor .....	118	111 Disk plough .....	158
84 Internal bearings for the tension/ take-up pulley of a belt conveyor .....	120	112 Plane sifter .....	160
85 Rigid idlers .....	122		
86 Idler garland .....	123		

Example Title .....Page

## **PRINTING PRESSES**

113 Impression cylinders of a newspaper  
rotary printing press ..... 162

114 Blanket cylinder of a sheet-fed offset  
press ..... 164

## **PUMPS**

115 Centrifugal pump ..... 165

116-117 Axial piston machines ..... 166

## **VENTILATORS, COMPRESSORS, FANS**

118 Exhauster ..... 169

119 Hot gas fan ..... 170

120 Fresh air blower ..... 171

## **PRECISION MECHANICS, OPTICS, ANTENNAS**

121 Optical telescope ..... 172

Radiotelescope ..... 174

122 Elevation axle ..... 175

123 Azimuth axis (track roller and king  
pin bearings) ..... 176

124 Data wheel ..... 177

**GLOSSARY** ..... 178

# 1 Traction motor for electric standard-gauge locomotives

## Operating data

Three-phase current motor supplied by frequency converter.

Nominal output 1,400 kW, maximum speed 4,300 min<sup>-1</sup> (maximum driving speed for transmissions with standard gear ratios is 200 km/h). One-end drive with herringbone gear pinion.

## Bearing selection, dimensioning

Collective loads which cover representative load cases for the motor torque, speeds, and percentages of time for the operating conditions in question, are used to determine bearing stressing.

Load case	$M_d$	$n$
	N m	%
1	6,720	
1,056	2	
2	2,240	
1,690	34	
3	1,920	
2,324	18	
4	3,200	
2,746	42	
5	2,240	
4,225	6	

The collective load is the basis for determining the average speeds (2,387 min<sup>-1</sup>) and the average driving speed (111 km/h). For each of the load cases the tooth load acting on the pinion and the reaction loads from the bearings have to be calculated both for forward and backward motion (percentage times 50 % each).

In addition to these forces, the bearings are subjected to loads due to the rotor weight, the unbalanced magnetic pull, unbalanced loads and rail shocks. Of these loads only the rotor weight,  $G_L$ , is known; therefore, it is multiplied by a supplementary factor  $f_z = 1.5 \dots 2.5$  – depending on the type of motor suspension. The bearing loads are determined from this estimated load. For the spring-suspended traction motor shown, a supplementary factor  $f_z = 1.5$  is used.

The bearing loads from weight and drive allow the resultant bearing loading to be determined by vector addition. In this example only the critical transmission-end bearing will be discussed. The *attainable life*  $L_{hna1\dots5}$  is determined for every load case using the formula  $L_{hna} = a_1 \cdot a_{23} \cdot L_h$  [h], taking into account the *operating viscosity*  $\nu$  of the transmission oil at 120 °C,

the *rated viscosity*  $\nu_1$  as well as the factors  $K_1$  and  $K_2$ . The basic  $a_{23II}$  factor is between 0.8 and 3. The *cleanliness factor*  $s$  is assumed to be 1. Then,  $L_{hna}$  is obtained using the formula:

$$L_{hna} = \frac{100}{\frac{q_1}{L_{hna1}} + \frac{q_2}{L_{hna2}} + \frac{q_3}{L_{hna3}} + \dots}$$

When selecting the bearing it should be ensured that the nominal mileage is reached and that, due to the high speed, the drive-end bearing is not too large. With the bearings selected the theoretical mileage of 2.5 million kilometers required by the customer can be reached.

A cylindrical roller bearing FAG NU322E.TVP2.C5.F1 serves as *floating bearing* at the drive end; an FAG 566513 with an angle ring HJ318E.F1 serves as *the locating bearing*.

The cylindrical roller bearing FAG 566513 is an NJ318E.TVP2.P64.F1, but its inner ring is 6 mm wider. The resulting *axial clearance* of 6 mm is required in order to allow the herringbone gearing on the pinion to align freely.

## Suffixes:

E	reinforced design
TVP2	<i>moulded cage</i> of glass fibre reinforced polyamide, <i>rolling element</i> riding
C5	<i>radial clearance</i> larger than C4
F1	FAG manufacturing and inspection specification for cylindrical roller bearings in traction motors which considers, among others, the requirements according to DIN 43283 "Cylindrical roller bearings for electric traction".
P64	<i>tolerance class</i> P6, <i>radial clearance</i> C4

## Machining tolerances

Drive end: shaft r5; end cap to M6  
Opposite end: shaft n5; end cap to M6

The bearings are fitted tightly on the shaft due to the high load, which is sometimes of the shock type. This reduces the danger of fretting corrosion, particularly at the drive end.

## Bearing clearance

Due to the tight *fits*, the inner ring of the bearing is expanded and the outer ring with the roller and cage

---

assembly is contracted. Thus the *radial clearance* of the bearing is reduced after mounting. It is further reduced during operation as the operating temperature of the inner ring is higher than that of the outer ring. For this reason bearings with an increased *radial clearance* (C4...C5) are mounted.

### Lubrication, sealing

The drive-end bearing is lubricated, due to the high speeds, with transmission *oil* ISO VG 320 with *EP additives*. No *sealing* is required between pinion and bearing so that a shorter cantilever can be used, thus reducing the bearing loading. Flinger edges and oil collecting grooves prevent the *oil* from escaping in the direction of the coil.

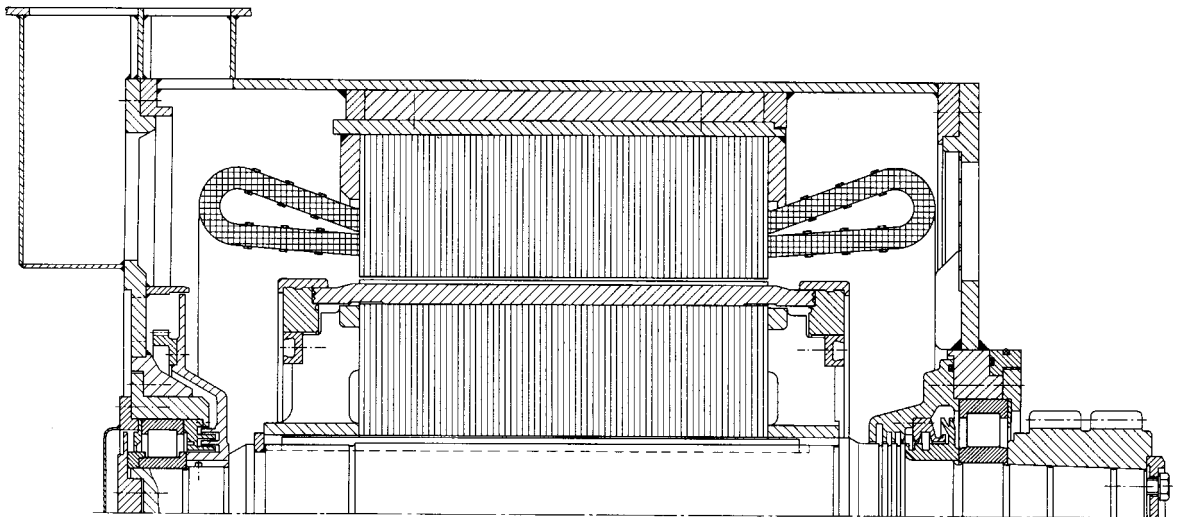

1: Traction motor for electric standard-gauge locomotive

---

# 2 Traction motor for electric commuter trains

---

The bearing at the opposite end is lubricated with a lithium soap base *grease* of *NLGI penetration* class 3 (FAG rolling bearing grease *Arcanol*L71V). The bearings should be relubricated after 400,000 kilometers or five years, respectively. Multiple labyrinths prevent contaminants from penetrating into the bearings.

## Operating data

Self-ventilated converter current motor, permanent power 200 kW at a speed of  $1,820 \text{ min}^{-1}$  (driving speed 72 km/h), maximum speed  $3,030 \text{ min}^{-1}$  (maximum driving speed 120 km/h), one-end drive with herringbone gear pinion.

## Bearing selection, dimensioning

The operating mode of commuter train motor vehicles is characterized by the short distances between stops. The periodic operating conditions – starting, driving, braking – can be recorded on an operating graph representing the motor torque versus the driving time. The cubic mean of the motor torque and an average speed, which is also determined from the operating graph, form the basis for the rolling bearing analysis. The mean torque is about 90 % of the torque at constant power.

The bearing loads are calculated as for traction motors for standard-gauge locomotives (example 1). They are made up of the reaction loads resulting from the gear force on the driving pinion and a theoretical radial load which takes into account the rotor weight, the magnetic pull, unbalanced loads and rail shocks. This theoretical radial load applied at the rotor centre of gravity is calculated by multiplying the rotor weight by the supplementary factor  $f_z = 2$ . The value 2 takes into account the relatively rigid motor suspension.

An overhung pinion provides the drive. At the pinion end a cylindrical roller bearing FAG NU320E.M1.P64.F1 is mounted as the *floating bearing*. At the commutator end a deep groove ball bearing FAG 6318M.P64.J20A very safely accommodates the thrust load resulting from the  $7^\circ$  helical gearing of the pinion, even at relatively high speeds.

---

## Current insulation

Where converter current motors with an output of more than 100 kW are used, ripple voltages can be caused by magnetic asymmetries. As a result, an induced circuit is generated between rotor shaft and stator which can cause current passage damage in the bearing.

To interrupt the flow of current, one bearing (in this case the deep groove ball bearing) is provided with current insulation.

Current-insulated bearings feature an oxide ceramic coating on the outer ring O.D.s and faces.

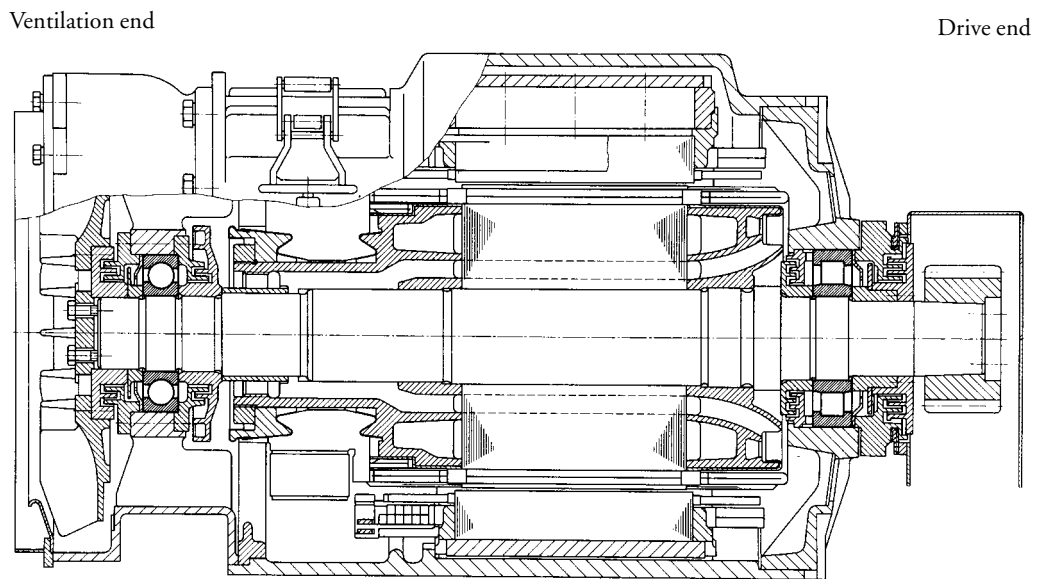

# 3 Three-phase current standard motor

## Operating data

Belt drive: Power 3 kW; rotor mass 8 kg; nominal speed  $2,800 \text{ min}^{-1}$ ; size 100 L; totally enclosed fan-cooled according to DIN 42673, sheet 1 – design B3, type of protection IP44, insulation class F.

## Bearing selection

Low-noise bearings in a simple, maintenance-free arrangement should be provided. These requirements are best met by deep groove ball bearings.

In DIN 42673, the shaft-end diameter specified for size 100 L is 28 mm. Consequently, a bore diameter of 30 mm is required. In this case a bearing of series 62 was selected for both bearing locations, i.e. an FAG 6206.2ZR.C3.L207. They guide the rotor shaft both at the drive side and at the ventilating side. The spring at the drive side provides clearance-free adjustment of the bearings and accommodates opposing axial loads on the rotor shaft.

By *adjusting* the deep groove ball bearings to zero clearance the adverse influence of bearing clearance on noise behaviour is eliminated.

## Bearing dimensioning

The calculation of the bearings for this motor differs somewhat from the usual approach. As not even the motor manufacturer knows the amount of load at the shaft end, the permissible radial loading is indicated in the motor catalogues.

To determine the radial load carrying capacity, the drive-side deep groove ball bearing is calculated. The calculation is based on an *attainable life*  $L_{\text{hna}}$  of 20,000 h and a *basic  $a_{23II}$*  value of 1.5. In addition, the rotor weight, the unilateral magnetic pull and the unbalanced load have to be taken into account. As the

latter two criteria are not known the rotor weight is simply multiplied by a supplementary factor of  $f_z = 1.5$ .

With these values a permissible radial loading of 1 kN is calculated for the shaft-end middle.

Since the operating load in most applications is lower than the admissible load, an *attainable life*  $L_{\text{hna}}$  of more than 20,000 hours is obtained. The life of electric motor bearings, therefore, is usually defined not by material fatigue but by the *grease service life*.

## Suffixes

- .2ZR Bearing with two shields
- C3 *Radial clearance* larger than PN (normal)
- L207 *Grease filling with Arcanol L207*

## Machining tolerances

Shaft to j5; end cap bore to H6.

The bore tolerance H6 ensures the slide fit required for free axial adjustment of both bearings.

## Lubrication, sealing

The .2ZR design with shields on both bearing sides has been successful in small and medium-sized electric motors. The *grease filling* in these bearings is sufficient for their entire *service life*. Increased operating temperatures must be taken into consideration in the case in question due to the insulation class F provided. For this reason the FAG high-temperature grease *Arcanol L207* is used. The shields prevent the grease from escaping and protect the bearings from contamination from the motor. Gap type *seals* protect the shaft opening at the drive side against dust and moisture. The requirements on insulation type IP44 are, therefore, met.

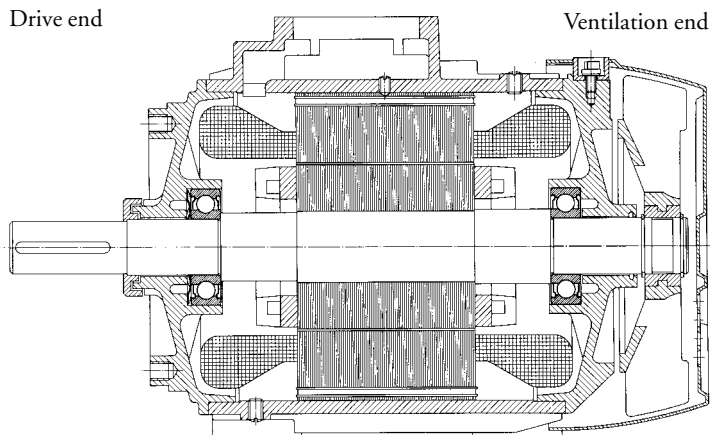

3: Three-phase current standard motor

# 4 Electric motor for domestic appliances

## Operating data

Power 30 W; speed 3,500 min<sup>-1</sup>.

## Bearing selection

Quiet running is the prime requirement for domestic appliance motors. The noise level of a motor is influenced by bearing quality (form and running accuracy), bearing clearance and the finish of the shaft and end cap bore.

Today, the quality of standard bearings already adequately meets the common noise requirements. Zero-clearance operation of the bearings is achieved by a spring washer lightly preloading the bearings in the axial direction.

The bearing seats on the shaft and in the end cap bores must be well aligned. To allow the spring washer to *adjust* the bearings axially, the outer rings have slide fits in the end caps.

A deep groove ball bearing FAG 626.2ZR is provided on the collector side, and an FAG 609.2ZR.L91 on the other side.

## Suffixes

- .2ZR Bearing with shields on both sides; they form a gap-type *seal*
- L91 special *grease* filling (*Arcanol* L91)

## Bearing dimensioning

The shaft diameter is usually dictated by the machine design, and as a result the bearings are sufficiently dimensioned with regard to *fatigue life*. Fatigue damage hardly ever occurs; the bearings reach the required life of between 500 and 2,000 hours.

## Machining tolerances

Shaft to j5; end cap bore to H5

The bore tolerance H5 provides the slide *fit* required to permit free axial alignment of both bearings.

## Sealing, lubrication

*Grease lubrication* with lithium soap base grease of *consistency* number 2 with an especially high degree of cleanliness. It is characterized by its low friction. The overall efficiency of this motor is considerably influenced by the frictional moment of the ball bearings. The bearings with shields (.2ZR design) are prelubricated with *grease*, i.e. regreasing is not required. The gap-type *seal* formed by the shields offers adequate protection against contamination under normal ambient conditions.

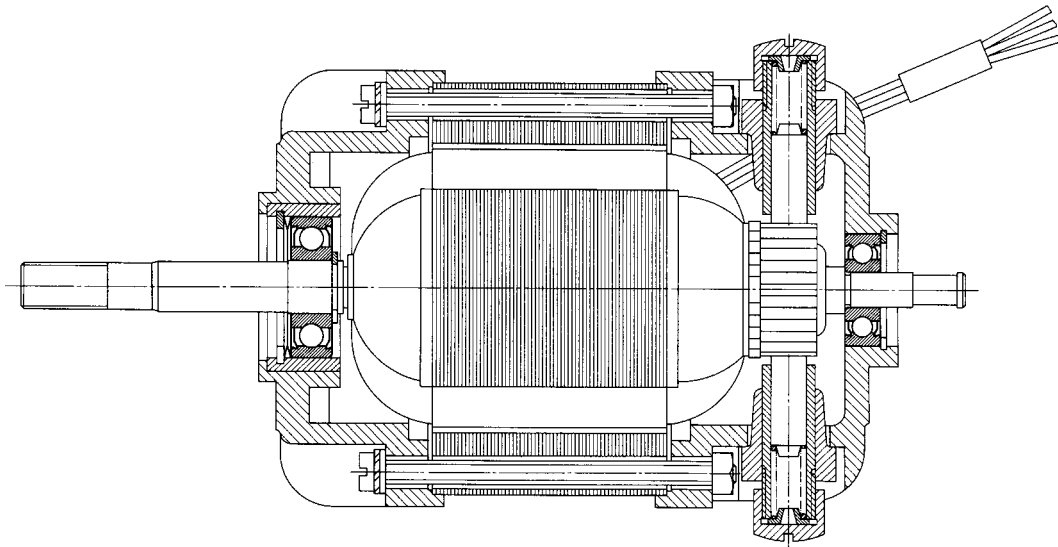

# 5 Drum of a domestic washing machine

## Operating data

Capacity 4.5 kg dry mass of laundry  
(weight  $G_w = 44 \text{ N}$ );  
Speeds: when washing  $50 \text{ min}^{-1}$   
when spinning after prewash cycle  $800 \text{ min}^{-1}$   
when dry spinning  $1,000 \text{ min}^{-1}$

## Bearing selection

The domestic washing machine is of the front loading type. The drum is overhung and pulley-driven. Bearing selection depends on the journal diameter which is determined by rigidity requirements, and also on the weight and unbalanced loads. Very simplified data is assumed for bearing load determination, on which the bearing dimensions are based, since loads and speeds are variable.

Domestic washing machines generally have several, partly automatic, washing cycles with or without spinning. During the actual washing cycle, i.e. a cycle without spinning, the drum bearings are only lightly loaded by the weight resulting from drum and wet laundry. This loading is unimportant for the bearing dimensioning and is thus neglected. The opposite applies to the spinning cycle: Since the laundry is unevenly distributed around the drum circumference, an unbalanced load arises which, in turn, produces a large centrifugal force. The bearing dimensioning is based on this centrifugal force as well as on the weights of the drum,  $G_T$ , and the dry laundry,  $G_w$ . The belt pull is generally neglected.

The centrifugal force is calculated from:

$$F_Z = m \cdot r \cdot \omega^2 \quad [\text{N}]$$

where

$$m = G_U / g \quad [\text{N} \cdot \text{s}^2 / \text{m}]$$

$G_U$  Unbalanced load [N]. 10...35 % of the dry laundry capacity is taken as unbalanced load.

$g$  Acceleration due to gravity =  $9.81 \text{ m/s}^2$

$r$  Radius of action of unbalanced load [m]  
Drum radius =  $d_T / 2$  [m]

$\omega$  Angular velocity =  $\pi \cdot n / 30$  [ $\text{s}^{-1}$ ]

$n$  Drum speed during spinning [ $\text{min}^{-1}$ ]

The total force for determination of the bearing loads thus is:  $F = F_Z + G_T + G_w$  [N]

This load is applied to the washing drum centre.

The bearing loads are:

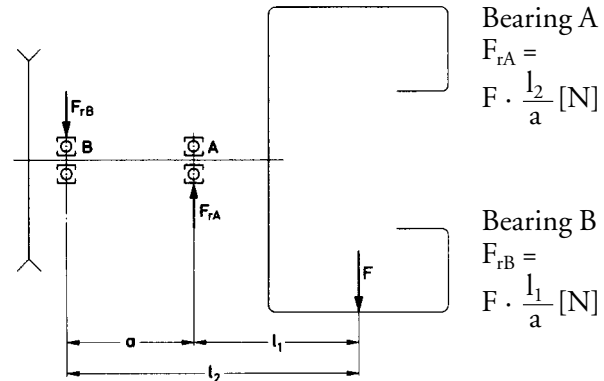

## Bearing dimensioning

The bearings for domestic washing machines are dimensioned for an *index of dynamic stressing*  $f_L = 0.85 \dots 1.0$ .

These values correspond to a *nominal life* of 300...500 hours of spinning.

In the example shown a deep groove ball bearing FAG 6306.2ZR.C3 was selected for the drum side and a deep groove ball bearing FAG 6305.2ZR.C3 for the pulley side.

The bearings have an increased *radial clearance* C3 and are *sealed* by shields (.2ZR) at both sides.

## Machining tolerances

Due to the unbalanced load  $G_U$ , the inner rings are subjected to *point load*, the outer rings to *circumferential load*. For this reason, the outer rings must have a tight *fit* in the housing; this is achieved by machining the housing bores to M6. The fit of the inner rings is not as tight; drum journal to h5. This ensures that the *floating bearing* is able to adjust in the case of thermal expansion. A loose fit also simplifies mounting.

## Lubrication, sealing

The bearings, *sealed* at both sides, are prelubricated with a special *grease*, sufficient for the bearing *service life*. There is an additional rubbing-type *seal* at the drum side.

---

---

Pulley

Drum

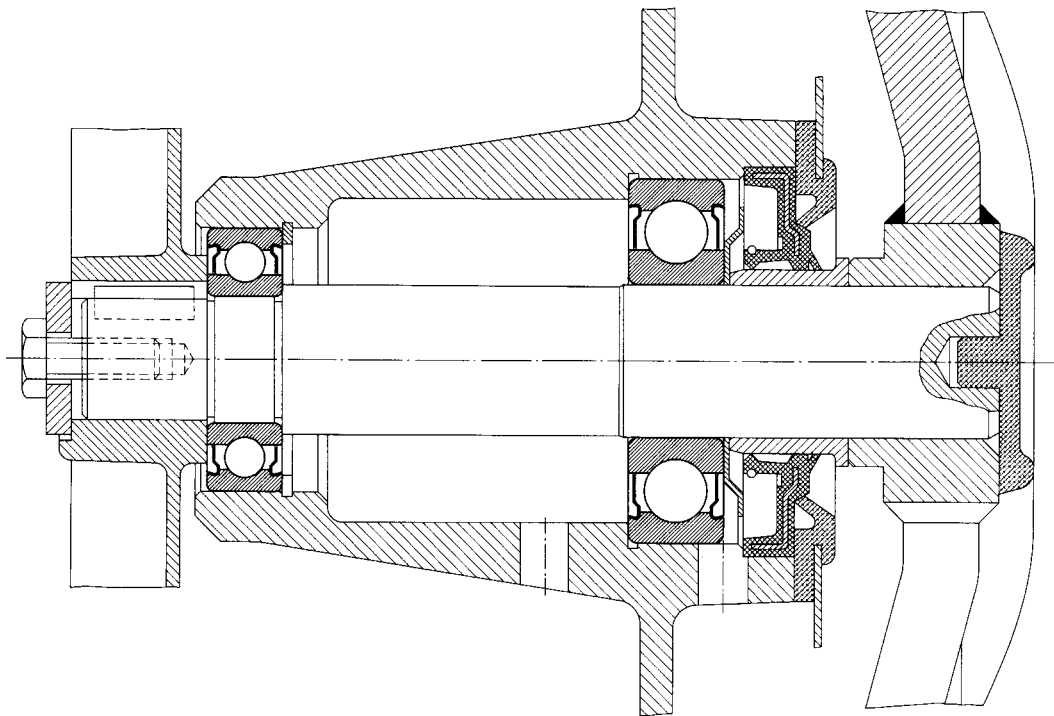

5: Drum mounting of a domestic washing machine

---

# 6 Vertical-pump motor

---

## Operating data

Rated horsepower 160 kW; nominal speed 3,000 min<sup>-1</sup>;  
Rotor and pump impeller mass 400 kg; pump thrust  
9 kN, directed downwards; type V1.

## Bearing selection

The selection of the bearings is primarily based on the main thrust, which is directed downwards. It is made up of the weight of the rotor and pump impeller (4 kN), the pump thrust (9 kN) and the spring preload (1 kN). When the motor idles the pump thrust may be reversed so that the bearings have, briefly, to accommodate an upward axial load of 4 kN, as well.

The radial loads acting on the bearings are not exactly known. They are made up by the unbalanced magnetic pull and potential unbalanced loads from the rotor and pump impeller. However, field experience shows that these loads are sufficiently taken into account by taking 50 % of the rotor and pump impeller mass, which in this case is 2 kN.

In the example shown, the supporting bearing is an angular contact ball bearing FAG 7316B.TVP which has to accommodate the main thrust. To ensure that no radial force acts on the bearing this part of the housing is radially relieved to clearance *fit* E8.

In normal operation, the deep groove ball bearing FAG 6216.C3 takes up only a light radial load and the axial spring preload; in addition, the thrust reversal load of the idling motor has to be accommodated.

As a result, the rotor is vertically displaced in the upward direction (ascending distance) which is limited by the defined gap between deep groove ball bearing face and end cap. To avoid slippage during the thrust reversal stage, the angular contact ball bearing is subjected to a minimum axial load by means of springs. On the pump impeller side a cylindrical roller bearing FAG NU1020M1.C3 acts as the *floating bearing*. As it accommodates the unbalanced loads from the pump impeller both the inner and the outer ring are fitted tightly.

The cylindrical roller bearing design depends on the shaft diameter of 100 mm, which in turn is dictated by strength requirements. Due to the relatively light radial load, the lighter series NU10 was selected.

## Machining tolerances

Cylindrical roller bearing:	Shaft to m5; housing to M6
Deep groove ball bearing:	Shaft to k5; housing to H6
Angular contact ball bearing:	Shaft to k5, housing to E8

## Lubrication

The bearings are lubricated with FAG rolling bearing grease *Arcanol* L71V and can be relubricated.

Replenishment quantity

– for the *floating bearing* 15 g

– for the *locating bearing* 40 g

The *relubrication interval* is 1,000 hours. The spent grease is collected in annular cover chambers provided below the bearing locations.

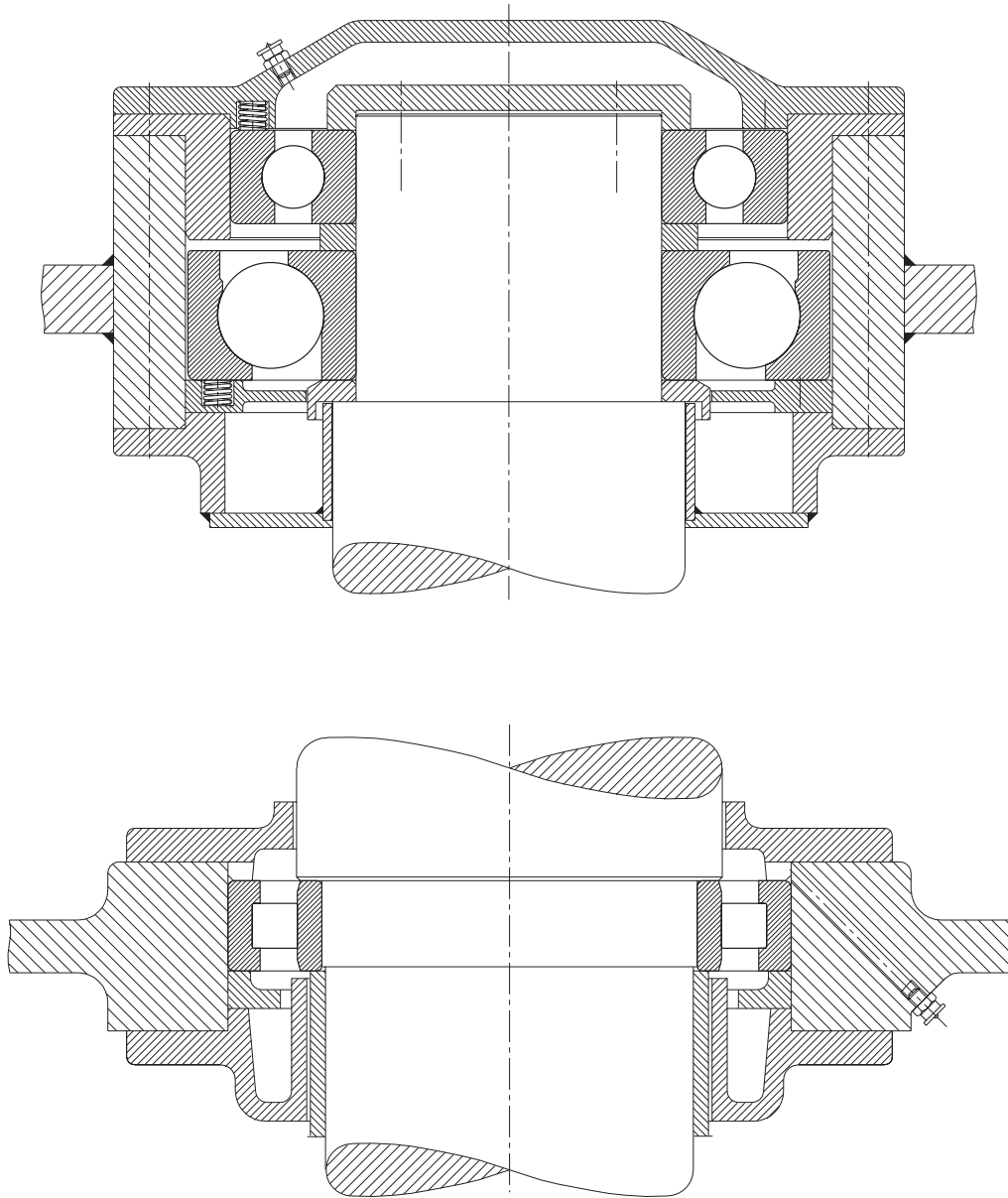

6: Rotor bearing arrangement of a vertical-pump motor

# 7 Mine fan motor

## Operating data

Rated horsepower 1,800 kW; speed  $n = 750 \text{ min}^{-1}$ ; Axial load  $F_a = 130 \text{ kN}$ ; radial load  $F_r = 3.5 \text{ kN}$ ; the bearings are vertically arranged.

## Bearing selection

The axial load of 130 kN is made up of the weight of the rotor and the two variable top and bottom fan impellers as well as the thrust of these fan impellers. They are supported by the upper *thrust bearing*.

The radial loads on vertical motors are only guiding loads. They are very small and generally result from the unbalanced magnetic pull and the potential rotor unbalanced load. In the example shown, the radial load per bearing is 3.5 kN. If the exact values are not known, these loads can be sufficiently taken into account, assuming that half the rotor weight acts as the radial load at the rotor centre of gravity.

The upper supporting bearing is a spherical roller thrust bearing FAG 29260E.MB. Radial guidance is ensured by a deep groove ball bearing FAG 16068M mounted on the same sleeve as the supporting bearing and accommodating the opposing axial loads on the rotor. Axial guidance is necessary for transporting and mounting as well as for motor idling. In this operating condition the counterflow of air can cause reversal of rotation and thrust. The axial displacement is limited to 1 mm in the upward direction so that the spherical roller thrust bearing does not lift off. Springs arranged below the housing washer (spring load 6 kN) ensure continuous contact in the bearings.

Radial guidance at the lower bearing position is provided by a deep groove ball bearing FAG 6340M; it is mounted with a slide fit as the floating bearing. Since it is only lightly loaded, it is preloaded with springs of 3 kN.

## Bearing dimensioning

Spherical roller thrust bearing FAG 29260E.MB has a *dynamic load rating* of  $C = 1430 \text{ kN}$ . The *index of dynamic stressing*  $f_L = 4.3$  is calculated with the axial load  $F_a = 130 \text{ kN}$  and the *speed factor* for roller bearings  $f_n = 0.393$  ( $n = 750 \text{ min}^{-1}$ ). The *nominal life*  $L_h = 65,000$  hours.

Based on the *operating viscosity*  $\nu$  of the *lubricating oil* (viscosity class ISO VG150) at approx.  $70 \text{ }^\circ\text{C}$ , the *rated viscosity*  $\nu_1$  and the *factors*  $K_1$  and  $K_2$ , a *basic*  $a_{23II}$  *value* of about 3 is determined. The *cleanliness factor*  $s$  is assumed to be 1. The *attainable life*  $L_{hna}$  of the thrust bearing is longer than 100,000 hours and the bearing is therefore sufficiently dimensioned. The two radial bearings are also sufficiently dimensioned with the *index of dynamic stressing*  $f_L > 6$ .

## Machining tolerances

### Upper bearing location

Spherical roller thrust bearing: Shaft to k5; housing to E8

Deep groove ball bearing: Shaft to k5; housing to H6

### Lower bearing location

Deep groove ball bearing: Shaft to k5; housing to H6

## Lubrication, sealing

*Thrust and radial bearings* at the upper bearing location are *oil-lubricated*.

The spherical roller thrust bearing runs in an oil bath and, due to its asymmetrical design, provides automatic circulation from the inner to the outer diameter. A tapered oil feeder and angled oilways supply the upper bearing. A retaining and a flinger ring ensure oil supply during start-up.

The lower bearing is *grease-lubricated* with provision for relubrication and a grease valve. Both bearing locations are *labyrinth-sealed*.

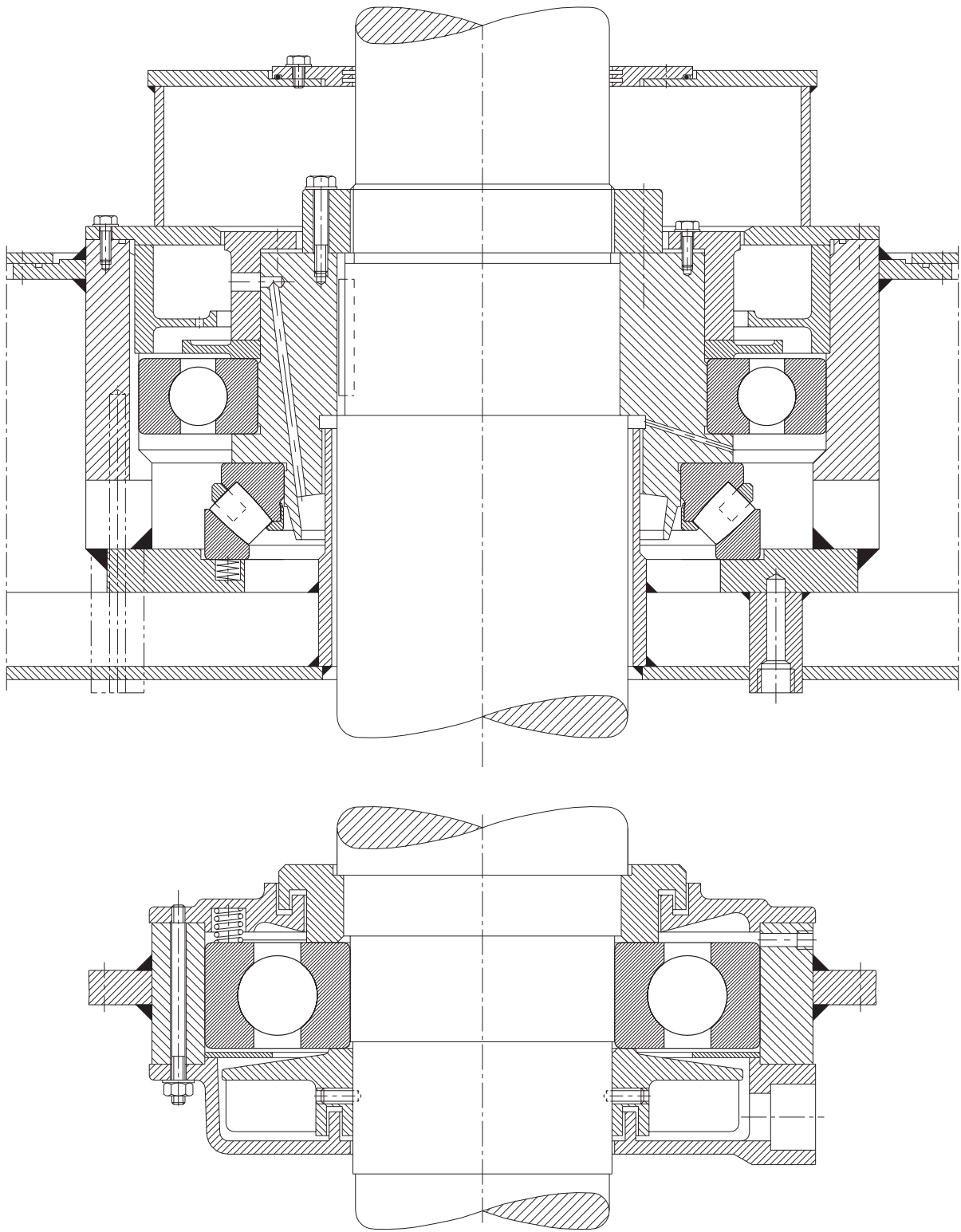

7: Rotor bearing arrangement of a mine fan motor

# 8 Rotor of a wind energy plant

Wind energy plants are among the alternative and environmentally friendly energy sources. Today, they generate powers of up to 3,200 kW. There are horizontal-rotor systems and vertical-rotor systems. The wind energy plant WKA60 is 44 meters high and features a three-blade horizontal rotor with a diameter of 60 m.

## Operating data

Nominal speed of the three-blade rotor =  $23 \text{ min}^{-1}$ ; gear transmission ratio  $i = 1:57.4$ ; electrical power 1,200 kW at a nominal rotor speed of the generator of  $n = 1,320 \text{ min}^{-1}$ .

## Bearing selection

A *service life* of 20 years was specified. To support the overhung blade rotor, spherical roller bearings FAG 231/670BK.MB (dimensions 670 x 1,090 x 336 mm) were selected for the *locating bearing* location and FAG 230/900BK.MB (dimensions 900 x 1,280 x 280 mm) for the *floating bearing* location.

## Bearing dimensioning

The recommended value for dimensioning the main bearings of wind energy plants is  $P/C = 0.08 \dots 0.15$ . The varying wind forces, causing vibrations, make it difficult to exactly determine the loads to be accommodated by the bearings. A *nominal life* of  $L_h > 130,000 \text{ h}$  was specified. For this reason, the mean equivalent load is, as a rule, determined on the basis of several load cases with variable loads, speeds and percentage times. The *locating bearing* of the WKA60 plant is subjected to radial loads of  $F_r = 400 \dots 1,850 \text{ kN}$  and thrust loads of  $F_a = 60 \dots 470 \text{ kN}$ . The *floating bearing* may have to accommodate radial loads of  $F_r = 800 \dots 1,500 \text{ kN}$ .

For the *locating bearing*, the radial and axial loads to be accommodated yield a mean *equivalent dynamic load* of  $P = 880 \text{ kN}$ . For the bearing FAG 231/670BK.MB with a *dynamic load rating* of  $C = 11,000 \text{ kN}$  this yields a load ratio of  $P/C = 880/11,000 = 0.08$ .

The *floating bearing* FAG 230/900BK.MB accommodates a mean radial force of  $F_r = P = 1,200 \text{ kN}$ . With a *dynamic load rating* of 11,000 kN a load ratio of  $1,200/11,000 = 0.11$  is obtained.

The *life values* calculated for the normally loaded spherical roller bearings (in accordance with DIN ISO 281) are far above the number of hours for 20-year continuous operation.

## Mounting and dismounting

To facilitate mounting and dismounting of the bearings, they are fastened on the shaft by means of hydraulic adapter sleeves FAG H31/670HGJS and FAG H30/900HGS. Adapter sleeves also allow easier adjustment of the required *radial clearance*.

The bearings are supported by one-piece plummer block housing of designs SUB (*locating bearing*) and SUC (*floating bearing*). The housings are made of cast steel and were checked by means of the finite-element method.

## Machining tolerances

The withdrawal sleeve seats on the rotor shaft are machined to h9 and cylindricity tolerance IT5/2 (DIN ISO 1101).

The bearing seats in the housing bore are machined to H7; this allows the outer ring of the *floating bearing* to be displaced.

## Lubrication, sealing

The bearings are lubricated with a lithium soap base grease of penetration class 2 with EP additives (FAG rolling bearing grease Arcanol L186V).

The housings are sealed on both sides by means of a double felt seal. A grease collar around the sealing gap prevents ingress of dust, dirt and, possibly, splash water.

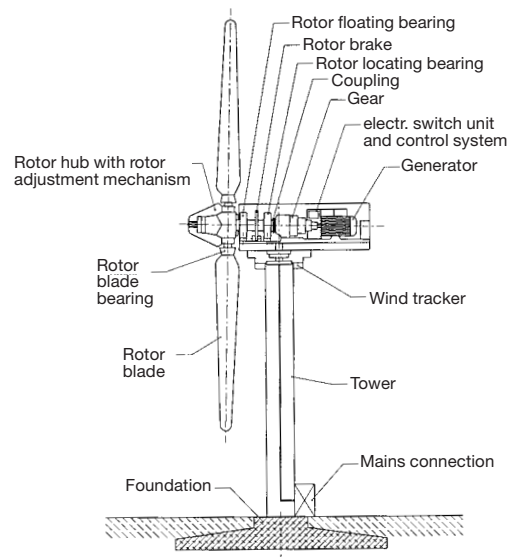

Wind energy plant, schematic drawing

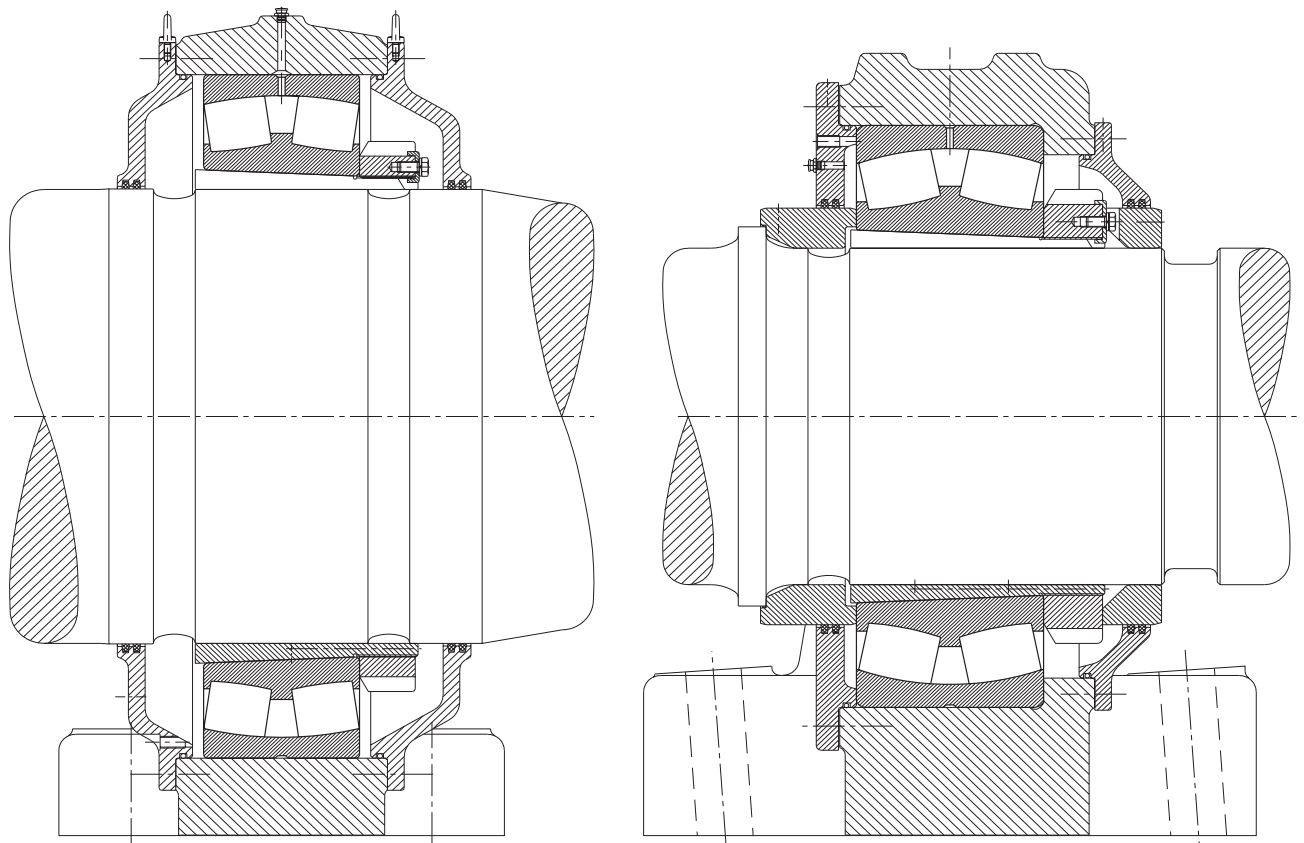

8: Rotor shaft bearings of a wind energy plant

# 9–18 Work spindles of machine tools

The heart of every machine tool is its main or work spindle and its work spindle bearings. The main quality characteristics of the spindle-bearing system are cutting volume and machining precision. Machine tools are exclusively fitted with rolling bearings of increased precision; mainly angular contact ball bearings and spindle bearings (radial angular contact ball bearings with *contact angles* of  $15^\circ$  and  $25^\circ$ , respectively), double-direction angular contact thrust ball bearings, radial and thrust cylindrical roller bearings and, occasionally, tapered roller bearings.

Depending on the performance data required for a machine tool, the spindle bearing arrangement is designed with ball or roller bearings based on the following criteria: rigidity, friction behaviour, precision, *speed suitability*, lubrication and *sealing*.

Out of a multitude of possible spindle bearing arrangements for machine tools a few typical arrangements have proved to be particularly suitable for application in machine tools (figs. a, b, c).

## Dimensioning

Usually, a *fatigue life* calculation is not required for the work spindles since, as a rule, to achieve the required spindle and bearing rigidity, bearings with such a large bore diameter have to be selected that, with increased or utmost cleanliness in the lubricating gap, the bearings are failsafe. For example, the *index of dynamic stressing*  $f_L$  of lathe spindles should be 3...4.5; this corresponds to a *nominal life* of  $L_h = 15,000 \dots 50,000$  h.

Example: The main spindle bearing arrangement of a CNC lathe (fig. a) is supported at the work end in three spindle bearings B7020E.T.P4S.UL in *tandem-O-arrangement* (*contact angle*  $\alpha_0 = 25^\circ$ ,  $C = 76.5$  kN,  $C_0 = 76.5$  kN). At the drive end, the belt pull is accommodated by a double-row cylindrical roller bearing NN3018ASK.M.SP. The cutting forces cause 50 % each of the axial reaction forces for the two *tandem-arranged* spindle bearings. The front bearing at the work end accommodates 60 % of the radial forces. It is loaded with  $F_r = 5$  kN,  $F_a = 4$  kN at  $n = 3,000$  min $^{-1}$ .

If the bearings are lubricated with the lithium soap base grease FAG Arcanol L74V (*base oil viscosity*  $23$  mm $^2$ /s at  $40^\circ\text{C}$ ), an *operating viscosity* of  $\nu = 26$  mm $^2$ /s will be obtained at an operating temperature of  $35^\circ\text{C}$ . With the mean bearing diameter  $d_m = 125$  mm and the speed  $n = 3,000$  min $^{-1}$  a *rated viscosity* of  $\nu_1 = 7$  mm $^2$ /s is obtained.

This yields a *viscosity ratio*  $\kappa = \nu/\nu_1 \approx 4$ ; i. e. the rolling contact areas are fully separated by a lubricant film. With  $\kappa = 4$ , a *basic  $a_{23II}$  factor* of 3.8 is obtained from the  $a_{23}$  diagram. Since the bearings, as a rule, are relatively lightly loaded ( $f_{s^*} > 8$ ), a very good *cleanliness factor* ( $s = \text{infinite}$ ) is obtained with increased ( $V = 0.5$ ) and utmost ( $V = 0.3$ ) cleanliness. Consequently, the *factor  $a_{23}$*  ( $a_{23} = a_{23II} \cdot s$ ), and thus the *attainable life* ( $L_{hna} = a_1 \cdot a_{23} \cdot L_h$ ) becomes infinite; the bearing is *failsafe*.

So, as long as  $f_{s^*} \geq 8$  and the main spindle bearings are lubricated well ( $\kappa \geq 4$ ), only the cleanliness in the lubricating gap determines whether the bearing is *failsafe* or not.

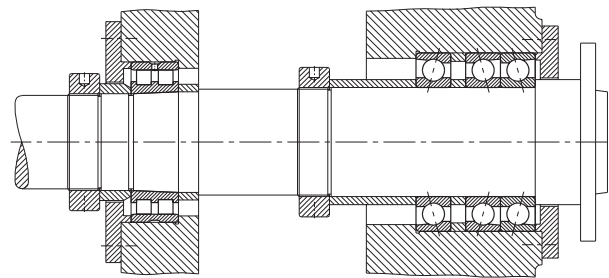

a: Spindle bearing arrangement with universal-design spindle bearings (spindle bearing set), subjected to combined load, at the work end and a single-row or double-row cylindrical roller bearing at the drive end which accommodates only radial loads.

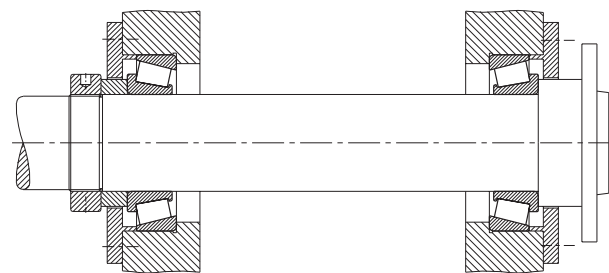

b: Spindle bearing arrangement with two tapered roller bearings in *O* arrangement. The bearings accommodate both radial and axial loads.

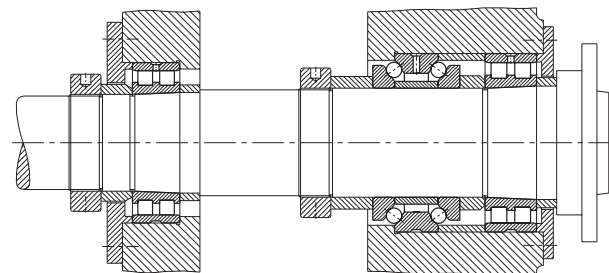

c: Spindle bearing arrangement with two double-row cylindrical roller bearings and a double-direction angular contact thrust ball bearing. Radial and axial loads are accommodated separately.

# 9 Drilling and milling spindle

## Operating data

Input power 20 kW; range of speed 11...2,240 min<sup>-1</sup>.

## Bearing selection

Radial and axial forces are accommodated separately. The *radial bearings* are double-row cylindrical roller bearings – an FAG NN3024ASK.M.SP at the work end and an FAG NN3020ASK.M.SP at the opposite end. The double-direction angular contact thrust ball bearing FAG 234424M.SP guides the spindle in axial direction. This bearing has a defined preload and *adjustment* is, therefore, not required.

Machining of the housing bore is simplified in that the nominal outside diameters of the *radial* and *thrust bearings* are the same. The O.D. tolerance of the angular contact thrust ball bearing is such as to provide a loose *fit* in the housing.

## Lubrication, sealing

Circulating *oil* lubrication.

The labyrinth *seal* at the work end consists of ready-to-mount, non-rubbing sealing elements. The inner labyrinth ring retains the *lubricating oil*, the outer labyrinth ring prevents the ingress of cutting fluid.

## Machining tolerances

Bearing	Seat	Diameter tolerance	Form tolerance (DIN ISO 1101)	Axial runout tolerance of abutment shoulder
Cylindrical roller bearing	Shaft, tapered Housing	Taper 1:12 K5	IT1/2 IT1/2	IT1 IT1
Angular contact thrust bearing	Shaft Housing	h5 K5	IT1/2 IT1/2	IT1 IT1

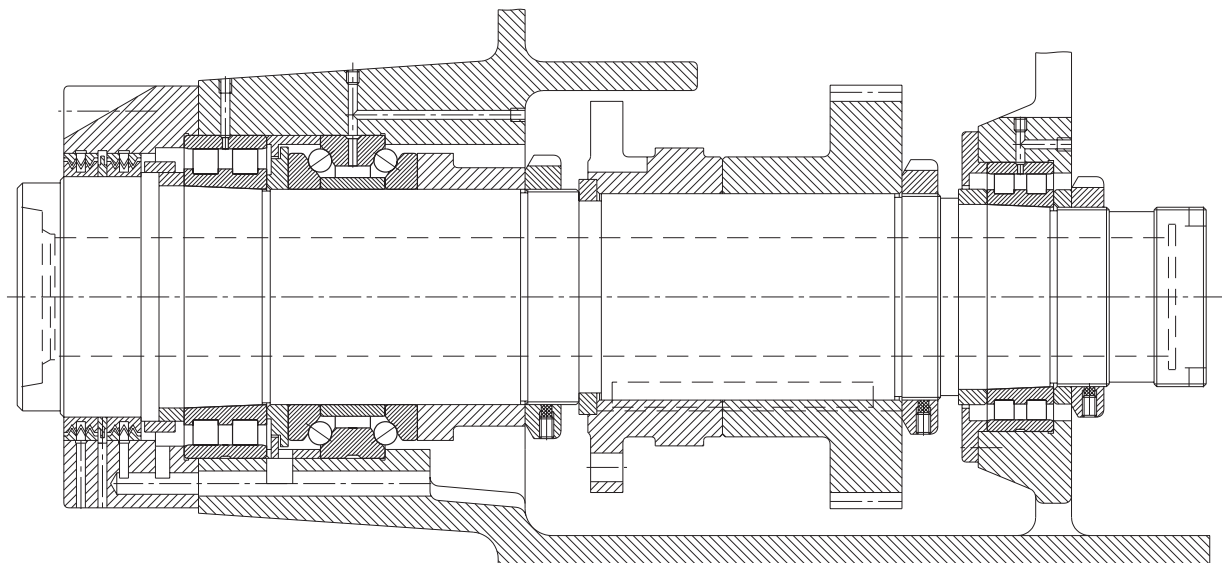

# 10 NC-lathe main spindle

## Operating data

Input power 27 kW;  
maximum spindle speed 9,000 min<sup>-1</sup>.

## Bearing selection

The main requirements on this bearing arrangement are an extremely good *speed suitability*, rigidity, and accurate guidance of the work spindle. At the work end, a spindle bearing set FAG B7017C.T.P4S.DTL in *tandem arrangement* is provided; at the drive end, a spindle bearing set FAG B71917C.T.P4S.DTL in *tandem arrangement*.

The bearings are lightly preloaded (UL) and have an increased precision (P4S).

The arrangement has no *floating bearing*; it is a rigid *locating bearing* system. Both bearing groups together form an *O arrangement*.

## Bearing dimensioning

The size of the bearings is primarily based on the spindle rigidity required, i. e. on the largest possible spindle diameter. The *fatigue life* of the bearings is taken into account for dimensioning but it does not play a dominating role in practice.

## Machining tolerances

Bearing	Seat	Diameter tolerance	Form tolerance (DIN ISO 1101)	Axial run-out tolerance of abutment shoulder
Spindle bearings	Shaft	+5/-5 µm	1.5 µm	2.5 µm
Drive end/work end	Housing	+2/+10 µm	3.5 µm	5 µm

Main spindle bearings do not normally fail due to material fatigue but as a result of *wear*; the *grease service life* is decisive.

## Bearing clearance

FAG spindle bearings of *universal design* are intended for mounting in *X*, *O* or *tandem arrangement* in any arrangement. When mounting in *X* or *O arrangement* a defined preload results. The light preload UL meets the normal requirements.

The original preload remains in the bearings due to outer and inner spacer sleeves of identical lengths. With a good bearing distance, the axial and radial heat expansions of the work spindle compensate each other so that the bearing preload remains unchanged under any operating condition.

## Lubrication, sealing

The bearings are greased for life with the FAG rolling bearing *grease Arcanol L74V* and about 35 % of the cavity is filled.

*Sealing* is provided by labyrinth *seals* with defined gaps.

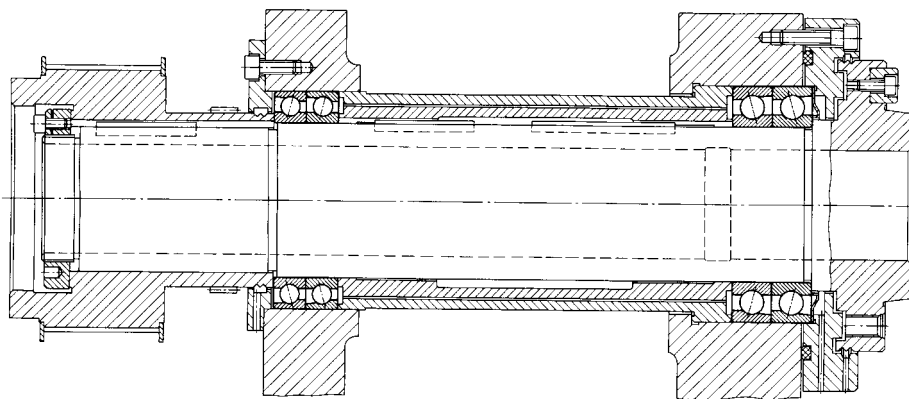

10: NC-lathe main spindle

# 11 CNC-lathe main spindle

## Operating data

Input power 25 kW;  
Speed range 31.5...5,000 min<sup>-1</sup>.

## Bearing selection

The bearings must accurately guide the spindle radially and axially and be very rigid. This is achieved by selecting as large a shaft diameter as possible and a suitable bearing arrangement. The bearings are preloaded and have an increased precision.

At the work end a spindle bearing set FAG B7018E.T.P4S.TBTL in *tandem-O-arrangement* with a light preload is mounted as *locating bearing*.

At the drive end there is a single-row cylindrical roller bearing FAG N1016K.M1.SP as *floating bearing*.

This bearing arrangement is suitable for high speeds and for high cutting capacities.

## Bearing dimensioning

The bearing size is primarily based on the spindle rigidity required, i.e. on the spindle diameter. The *fatigue life* of the bearings is taken into account for dimensioning but it does not play a dominating role in practice.

## Machining tolerances

Bearing	Seat	Diameter tolerance	Form tolerance (DIN ISO 1101)	Axial runout tolerance of abutment shoulder
Spindle bearings	Shaft	+5/-5 µm	1.5 µm	2,5 µm
	Housing	-4/+8 µm	3.5 µm	5 µm
Cylindrical roller bearings	Shaft, tapered	Taper 1:12	1.5 µm	2.5 µm
	Housing	-15/+3 µm	3.5 µm	5 µm

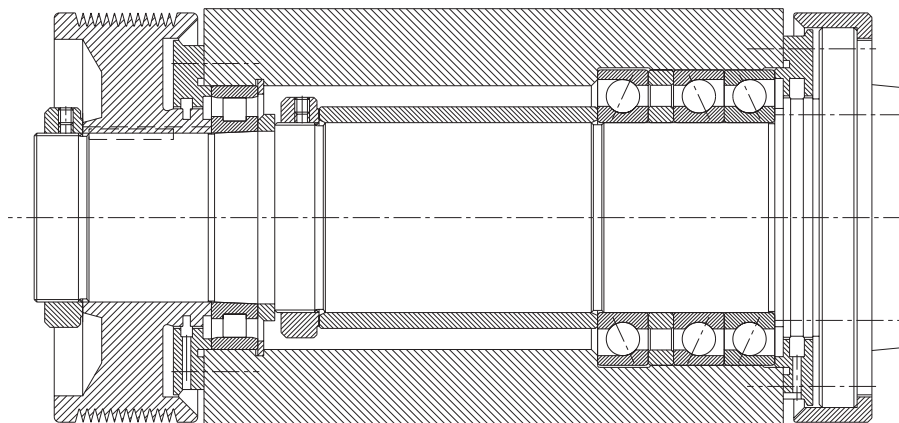

11: CNC-lathe main spindle

Apart from the Hertzian contact pressure, the *service life* of the bearings is mainly dictated by the *grease service life*. Main spindle bearings do not normally fail due to material fatigue but as a result of *wear*.

## Bearing clearance

FAG spindle bearings of *universal design* are intended for mounting in *X*, *O* or *tandem arrangement* in any arrangement. When mounting in *X* or *O arrangement* a set preload results. The light preload UL meets the normal requirements.

The cylindrical roller bearing is adjusted with almost zero *radial clearance* by axially pressing the tapered inner ring onto the spindle.

## Lubrication, sealing

The bearings are greased for life with the FAG rolling bearing grease *Arcanol L74V*.

Approximately 35% of the spindle bearing cavity and approximately 20% of the cylindrical -roller bearing cavity is filled with *grease*.

*Sealing* is provided by a labyrinth with set narrow radial gaps.

# 12 Plunge drilling spindle

## Operating data

Input power 4 kW;  
maximum spindle speed 7,000 min<sup>-1</sup>.

## Bearing selection

Accurate axial and radial guidance of the drilling spindle is required. Consequently, bearing selection is based on the axial loads to be accommodated while providing the greatest possible axial rigidity. Another criterion is the available space which, e.g. in the case of multispindle cutter heads, is limited.

Work end:

1 spindle bearing set FAG B71909E.T.P4S.TTL  
(three bearings mounted in *tandem arrangement*)

Drive end:

1 spindle bearing set FAG B71909E.T.P4S.DTL  
(two bearings mounted in *tandem arrangement*).

The two bearing sets can also be ordered as a single set of five:

FAG B71909E.T.P4S.PBCL (*tandem pair* mounted against three *tandem-arranged* bearings in *O arrangement*, lightly preloaded). This bearing arrangement includes no *floating bearing*; it forms a rigid *locating bearing system*.

## Bearing dimensioning

The bearing size is based on the spindle rigidity required, i.e. on as large a spindle diameter as possible.

## Machining tolerances

Bearing	Seat	Diameter tolerance	Form tolerance (DIN ISO 1101)	Axial runout tolerance of abutment shoulder
Spindle bearing (drive/work end)	Shaft Housing	+3.5/-3.5 μm -3/+5 μm	1 μm 2 μm	1.5 μm 3 μm

As regards loading, the bearings usually have a *stress index*  $f_{s^*} > 8$  and are, consequently, *failsafe*. The *bearing life* is significantly influenced by a good *sealing* which allows the *grease service life* to be fully utilized.

## Bearing clearance

FAG spindle bearings of *universal design* are intended for mounting in *X*, *O* or *tandem arrangement* in any arrangement. When mounting in *X* or *O arrangement*, a set preload results. The light preload UL meets the normal requirements.

The original preload remains in the bearings due to outer and inner spacer sleeves of identical lengths. With a good bearing distance, the axial and radial heat expansions of the work spindle compensate each other so that the bearing preload remains unchanged under any operating condition.

## Lubrication, sealing

The bearings are greased for life with the FAG rolling bearing grease Arcanol L74V and about 35 % of the cavity is filled.

*Sealing* is provided by labyrinth *seals* with a collecting groove and a drain hole where a syphon may be provided.

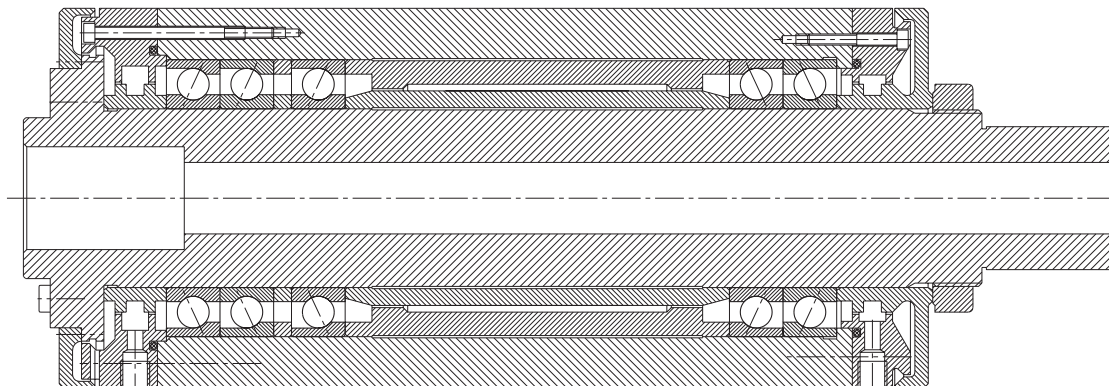

12: Drilling spindle bearing arrangement

# 13 High-speed motor milling spindle

## Operating data

Input power 11 kW;  
maximum spindle speed 28,000 min<sup>-1</sup>.

## Bearing selection

The bearings must be suitable for very high speeds and for the specific thermal operating conditions in a motor spindle. Hybrid spindle bearings with ceramic balls are particularly suitable for this application. Milling spindles must be guided extremely accurately both in the axial and in the radial direction.

Work end:

1 spindle bearing set FAG HC7008E.T.P4S.DTL in *tandem arrangement*.

Drive end:

1 spindle bearing set FAG HC71908E.T.P4S.DTL in *tandem arrangement*.

The bearing pairs at drive end and work end are mounted in *O arrangement* and elastically *adjusted* by means of springs (spring load 300 N), corresponding to a medium preload. The bearing pair at the drive end is mounted on a sleeve which is supported on a linear ball bearing with zero clearance so that axial length variations of the shaft can be freely compensated for.

## Machining tolerances

Bearing	Seat	Diameter tolerance	Form tolerance (DIN ISO 1101)	Axial runout tolerance of abutment shoulder
Spindle bearing (drive/work end)	Shaft Housing	+6/+10 μm -3/+5 μm	1 μm 2 μm	1.5 μm 3 μm

## Bearing dimensioning

Bearing size and bearing arrangement are selected on the basis of the specified speed and on the spindle diameter.

Two other factors that have to be taken into account are the heat generated by the motor, which causes a major temperature difference between the inner ring and the outer ring of the bearing, and the ring expansion which makes itself felt by the centrifugal force resulting from the high speed. In a rigid bearing arrangement, this would considerably increase the preload. Due to the spring preload, both these influences are easily compensated for. As a result, the contact pressure in the rolling contact area of the bearing is relatively low ( $p_0 \leq 2,000 \text{ N/mm}^2$ ), and the bearings are *failsafe*. Consequently, the service life of the bearings is dictated by the *grease service life*.

## Lubrication, sealing

The bearings are lubricated with rolling bearing *grease Arcanol L207V* which is particularly suitable for the greater thermal stressing and for high speeds. To protect the *grease* from contamination, and consequently to increase the *grease service life*, the bearings are sealed by labyrinths consisting of a gap-type *seal* with flinger grooves and a collecting groove.

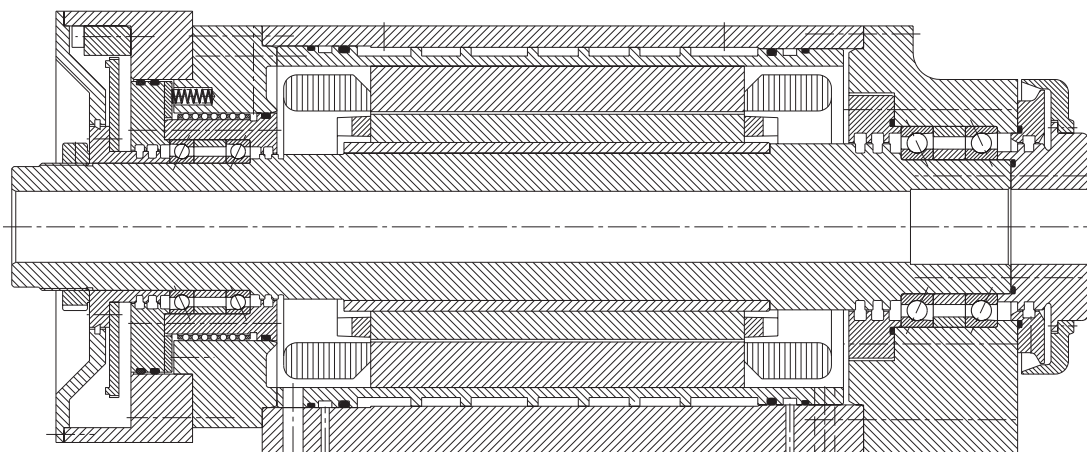

13: Bearing arrangement of a high-speed motor milling spindle

# 14 Motor spindle of a lathe

## Operating data

Input power 18 kW;  
maximum spindle speed 4,400 min<sup>-1</sup>.

## Bearing selection

The bearings must be very rigid and accurately guide the spindle in the radial and axial direction. This is achieved by selecting as large a shaft diameter as possible and a suitable bearing arrangement. The bearings are preloaded and have an increased precision. Also, the specific thermal conditions found in a motor bearing arrangement have to be taken into account.

Work end: 1 spindle bearing set  
FAG B7024E.T.P4S.QBCL  
(*tandem-O-tandem arrangement*)  
as *locating bearing*

Opposite end: 1 cylindrical roller bearing  
FAG N1020K.M1.SP  
as *floating bearing*.

## Bearing dimensioning

As the bearing size primarily depends on the spindle rigidity (larger spindle diameter) bearing sizes are

obtained whose load carrying capacity is more than adequate.

Consequently, the *service life* of the bearings is primarily dictated by the *grease service life*.

## Bearing clearance

The spindle bearings are mounted with a light preload. The cylindrical roller bearing is *adjusted* to a *radial clearance* of a few μm by axially pressing the tapered inner ring onto the tapered shaft seat and reaches the required zero clearance at operating temperature.

## Lubrication, sealing

The bearings are lubricated for life with the rolling bearing *grease Arcanol L207V*. This *grease* is particularly suitable for increased temperatures and high speeds. Approximately 35 % of the spindle bearing cavity and approximately 20 % of the cylindrical-roller bearing cavity is filled with grease.

*Sealing* is provided by a stepped labyrinth with collecting grooves and drain holes. A gap-type *seal* protects the cylindrical roller bearing from external contamination.

## Machining tolerances

Bearing	Seat	Diameter tolerance	Form tolerance (DIN ISO 1101)	Axial runout tolerance of abutment shoulder
Spindle bearing	Shaft	-5/+5 μm	1.5 μm	2.5 μm
	Housing	-4/+10 μm	3.5 μm	5 μm
Cylindrical roller bearing	Shaft, tapered	1:12	1.5 μm	2.5 μm
	Housing	-15/+3 μm	3.5 μm	5 μm

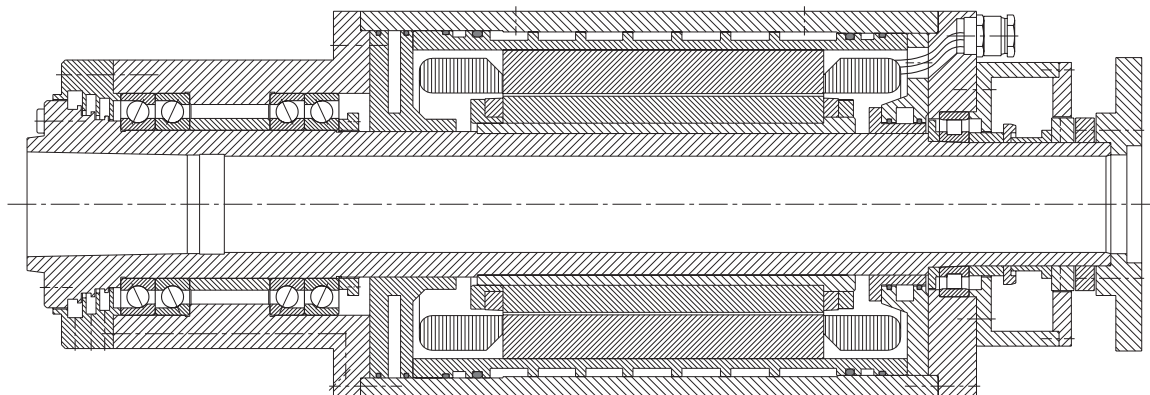

14: Motor spindle bearing arrangement of a lathe

# 15 Vertical high-speed milling spindle

## Operating data

Input power 2.6/3.14 kW;  
Nominal speed 500...4,000 min<sup>-1</sup>.

## Bearing selection

The bearings must operate reliably over the entire speed range from 500 to 4,000 min<sup>-1</sup>. For example, the spindle must be rigidly guided at 500 min<sup>-1</sup> under heavy loads both in the radial and axial direction. On the other hand, at the maximum speed of 4,000 min<sup>-1</sup>, the bearing temperature must not be so high as to impair accuracy.

At the milling spindle work end a spindle bearing set FAG B7014E.T.P4S.TBTM are mounted in *tandem-O-arrangement* with a medium preload. The bearing group is preloaded with 1.9 kN by means of a nut and a spacer sleeve.

The deep groove ball bearing FAG 6211TB.P63 guides the spindle at the drive end. To ensure clearance-free operation this bearing is lightly preloaded by means of Belleville spring washers.

## Bearing dimensioning

Milling spindles must be resistant to deflection and torsion. This requirement dictates the spindle diameter and the bearing size. The required bearing rigidity is obtained by the chosen bearing arrangement and preload. The two angular contact ball bearings arranged at the upper drive end accommodate the driving forces.

## Machining tolerances

Seat	Diameter tolerance	Cylindricity tolerance (DIN ISO 1101)	Axial runout tolerance of abutment shoulder
Shaft	js4	IT1/2	IT1
Housing (work end)	JS5	IT2/2	IT2
Housing (drive end)	H6	IT3/2	IT3

## Lubrication, sealing

The bearings are *grease lubricated* (FAG rolling bearing grease *Arcanol*L74V).

A gap-type *seal* with oil splash ring and collecting grooves protect the spindle bearings from contamination.

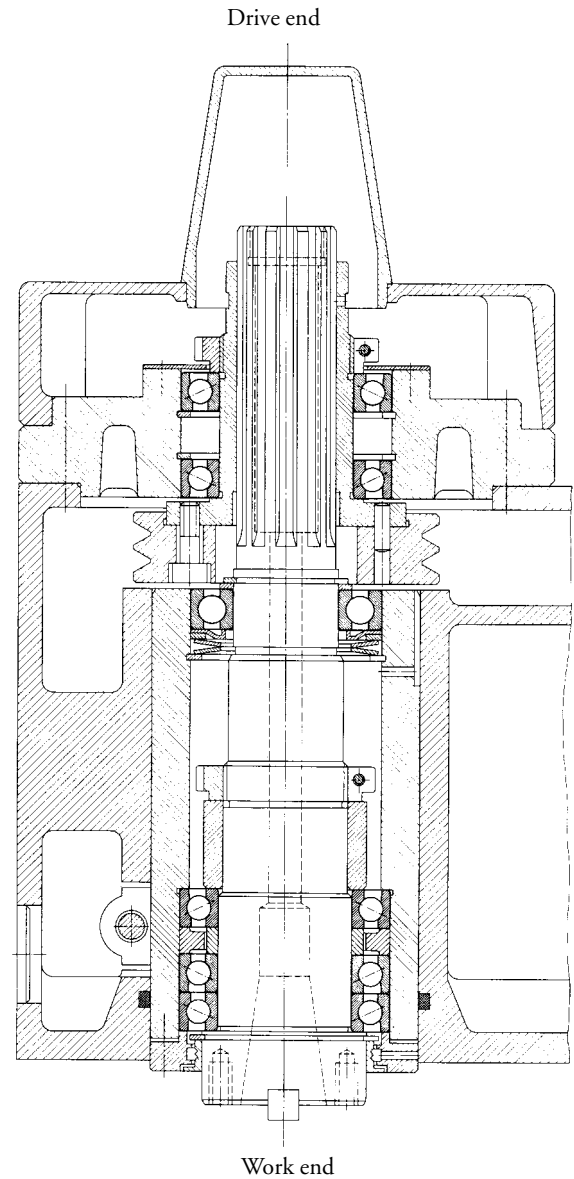

15: Bearing arrangement of a vertical high-speed milling spindle

# 16 Bore grinding spindle

## Operating data

Input power 1.3 kW; spindle speed 16,000 min<sup>-1</sup>.  
The spindle is radially loaded by the grinding pressure.  
The load depends on grinding wheel quality, feed and depth of cut.

## Bearing selection

Due to the high speeds required during bore grinding, the spindle speeds must also be high. Sufficient rigidity and accurate guidance, especially in axial direction, are also required. The demands for high speed and high rigidity can be met with spindle bearings. As the spindle requires primarily a high radial rigidity, it is advisable to provide bearings with a *contact angle* of 15° (design C).

At the work end and at the drive end there is one spindle bearing set FAG B7206C.T.P4S.DTL in *tandem arrangement* each. The load is equally shared by these *O arranged* tandem bearing pairs. For this purpose the

spacer rings must be identical in width and also flush ground.

The bearings are lightly preloaded by a coil spring for clearance-free operation under all operating conditions. The preload increases the rigidity of the bearing arrangement. It is, however, limited by the permissible bearing temperature and varies between 300 and 500 N depending on the spindle application.

The spindle diameter, which determines the bearing size, is based on the required rigidity.

## Lubrication, sealing

*Grease lubrication* for high-speed bearings (FAG rolling bearing grease *Arcanol L74V*). The bearings are lubricated for *life* during mounting and therefore no relubrication is required.

The high-speed bearings require the use of non-rubbing *seals*, in this case labyrinth seals.

## Machining tolerances

Seat	Diameter tolerance	Cylindricity tolerance (DIN ISO 1101)	Axial runout tolerance of abutment shoulder
Shaft	js3	IT0/2	IT0
Housing (drive end)	+2/+6 μm	IT1/2	IT1
Housing (work end)	-1/+3 μm	IT1/2	IT1

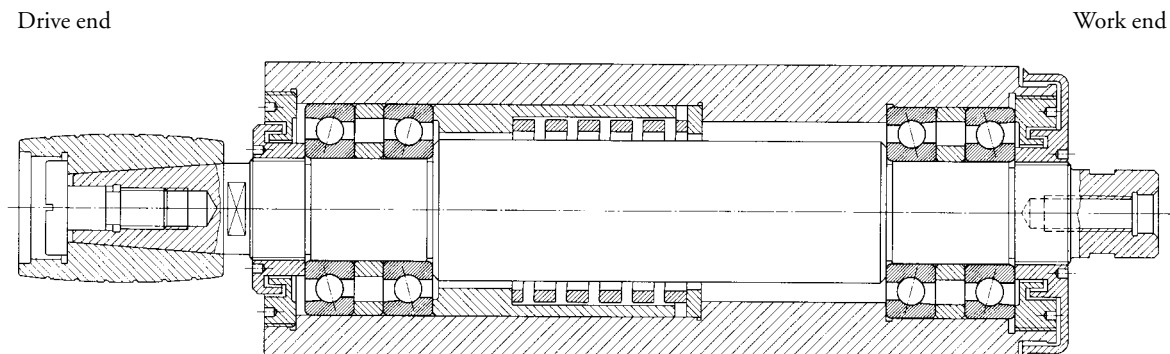

16: Bearing arrangement of a bore grinding spindle

# 17 External cylindrical grinding spindle

## Operating data

Input power 11 kW; speed  $n = 7,500 \text{ min}^{-1}$ ; running accuracy: radially  $3 \mu\text{m}$ , axially  $1 \mu\text{m}$ .

## Bearing selection

During external cylindrical grinding a high cutting capacity is required (for rough grinding) and a high standard of form and surface quality (for fine grinding). A high degree of rigidity and running accuracy as well as good damping and *speed suitability* form the main criteria for the bearing arrangement. These requirements are met by *precision bearings*.

Sealed universal spindle bearings with small steel balls (HSS) are used:

- at the work end: 1 spindle bearing set  
FAG HSS7020C.T.P4S.QBCL in double-*O arrangement* as *locating bearing*
- at the drive end: 1 spindle bearing set  
FAG HSS7020C.T.P4S.DBL in *O arrangement* as *floating bearing*

Where even higher speeds have to be accommodated, it is advisable to use sealed hybrid spindle bearings HCS with small ceramic balls (lower centrifugal forces).

## Bearing dimensioning

The required spindle diameter or the specified outside diameter of the quill determines the bearing size. The *contact angle* of  $15^\circ$  is suitable for high radial rigidity. Damping and running accuracy are improved by arranging four bearings at the work end.

## Bearing clearance

All UL *universal design* bearings are lightly preloaded when mounted in *O arrangement*. Spacers improve the thermal conditions and provide a larger *spread* at the bearing location. To ensure that the defined bearing preload is not altered by the spacers, the latter must be identical in width and flush ground.

## Lubrication, sealing

The sealed FAG HSS spindle bearings require no maintenance and are lubricated for life with the FAG rolling bearing *grease Arcanol L74*. Additional *sealing* is provided at the grinding wheel end by a labyrinth with defined narrow axial gaps of  $0.3 \dots 0.8 \text{ mm}$ . A plain labyrinth *seal* is sufficient at the drive end.

## Machining tolerances

Bearing	Seat	Diameter tolerance	Form tolerance (DIN ISO 1101)	Axial runout tolerance of abutment shoulder
Spindle bearing (work end)	Shaft Housing	$+3/-3 \mu\text{m}$ $-3/+5 \mu\text{m}$	$1 \mu\text{m}$ $2 \mu\text{m}$	$1.5 \mu\text{m}$ $3.5 \mu\text{m}$
Spindle bearing (drive end)	Shaft Housing	$+3/-3 \mu\text{m}$ $+5/+13 \mu\text{m}$	$1 \mu\text{m}$ $2 \mu\text{m}$	$1.5 \mu\text{m}$ $3.5 \mu\text{m}$

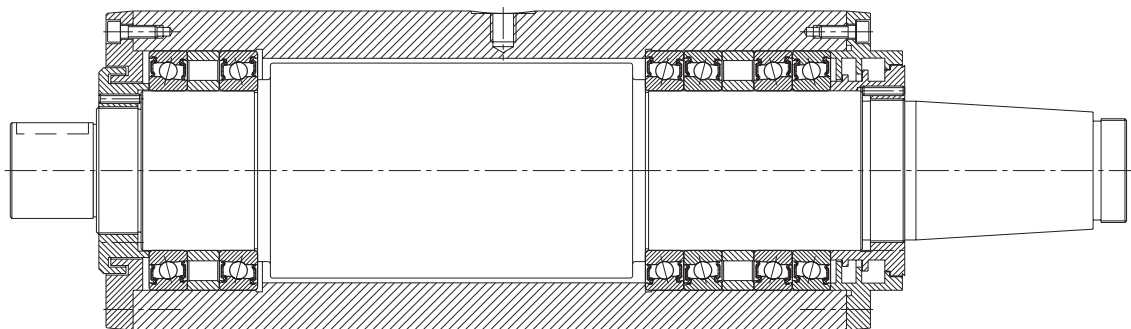

17: Bearing arrangement of an external cylindrical grinding spindle

# 18 Surface grinding spindle

## Operating data

Grinding motor power 220 kW; maximum speed  $375 \text{ min}^{-1}$ ; weight of spindle, rotor and grinding spindle head 30 kN; maximum grinding pressure 10 kN.

## Bearing selection

The spindle is supported at the grinding spindle head by a double-row cylindrical roller bearing FAG NN3060ASK.M.SP. The thrust ball bearing FAG 51164MP.P5 arranged above this bearing absorbs the thrust component of the grinding pressure. The upper end of the spindle is fitted with a double-row cylindrical roller bearing FAG NN3044ASK.M.SP and a thrust ball bearing FAG 51260M.P6. The cylindrical roller bearing provides radial guidance; the thrust ball bearing carries the weight of the rotor, spindle, and spindle head. To increase axial rigidity this bearing is adjusted with Belleville spring washers against the lower thrust ball bearing.

## Bearing dimensioning

Rigid spindle guidance in the radial direction is ensured by accurately dimensioned mating parts, tight *fits* of the rings, and a light preload of the cylindrical roller bearings. The inner rings are pushed along the tapered bearing seat until the roller-and-cage assembly runs under a light preload ( $5 \mu\text{m}$ ). Surface finish and dimensional accuracy of the workpiece mainly depend on the axial rigidity of the spindle headstock and of the rotary table. Therefore, the rigidity of the *thrust bearings* is especially important. To increase the rigidity, the thrust bearings are preloaded to 40 kN by Belleville spring washers at the upper end of the spindle. Since the combined weight of spindle, rotor, and spindle head is 30 kN, the lower *thrust bearing* is preloaded to 10 kN. Rigid, clearance-free spindle guidance also in the axial direction is, therefore, guaranteed. The nominal rigidity is  $2.5 \text{ kN}/\mu\text{m}$ ; the spindle deviates axially by only  $4 \mu\text{m}$  with the maximum grinding pressure of 10 kN.

## Lubrication, sealing

The headstock bearings are lubricated for life with FAG rolling bearing *grease Arcanol L74V*. A gap-type *seal* suffices at the upper spindle end since the headstock is protected by a cap. A shaft seal prevents *grease* from penetrating into the motor. The lower bearings are sealed at the motor end with a gap-type *seal* and at the spindle head with a gap-type *seal* preceded by a labyrinth.

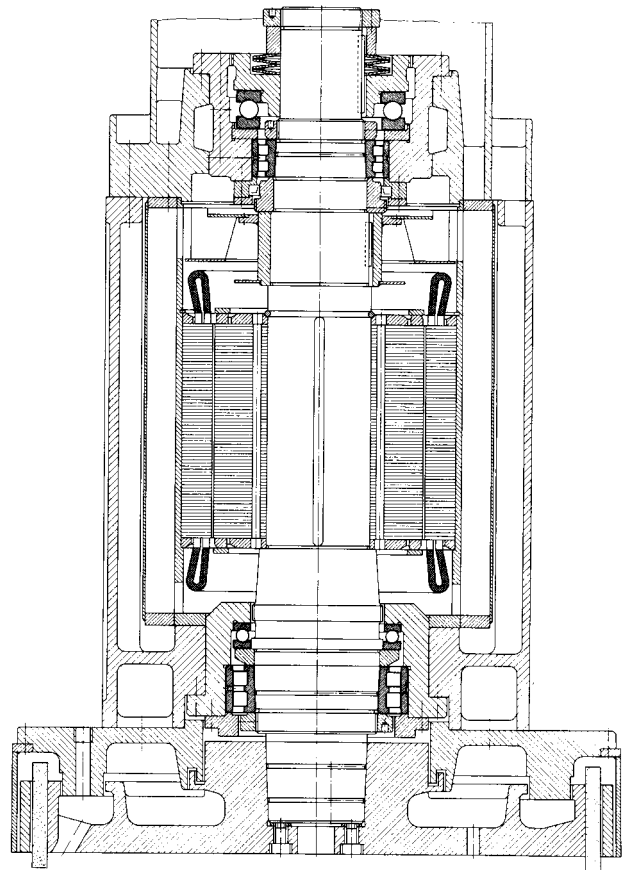

18: Bearing arrangement of a surface grinding spindle

# 19 Rotary table of a vertical lathe

## Operating data

Input power 100 kW; speeds up to  $n = 200 \text{ min}^{-1}$ ; rotary table O.D. 2,000, 2,200 or 2,500 mm; maximum workpiece diameter 2,800 mm, maximum workpiece height 2,700 mm, maximum workpiece weight 250 kN; maximum radial and axial runout  $5 \mu\text{m}$ .

## Bearing selection

The face plate bearings must provide a high running accuracy and rigidity. As the thrust load predominates and eccentric load application causes a great tilting moment, a thrust ball bearing of increased precision (main dimensions  $1,250 \times 1,495 \times 150 \text{ mm}$ ) is installed. Radial guidance is provided by an angular contact ball bearing of increased precision, FAG 7092MP.P5 ( $30^\circ$  contact angle). Both bearings are preloaded against each other with 50 kN.

The high preload guarantees a high running accuracy while ensuring a high radial and axial moment or tilting rigidity and keeping internal heating relatively low. By taking special measures during mounting and after final grinding of the rotary table a maximum axial run-out of  $5 \mu\text{m}$  is obtained.

## Machining tolerances

Thrust ball bearing: gearing to j5

Angular contact ball bearing: kingpin to j5/gearing to K6

## Lubrication, sealing

The bearings have circulating *oil* lubrication.

The oil is fed directly to the various bearings through oil feed ducts. After flowing through the bearings, the oil passes through a filter and into an oil collecting container from where it returns to the bearings.

The labyrinth *seal* prevents the *oil* from escaping from the bearings and protects them from contamination.

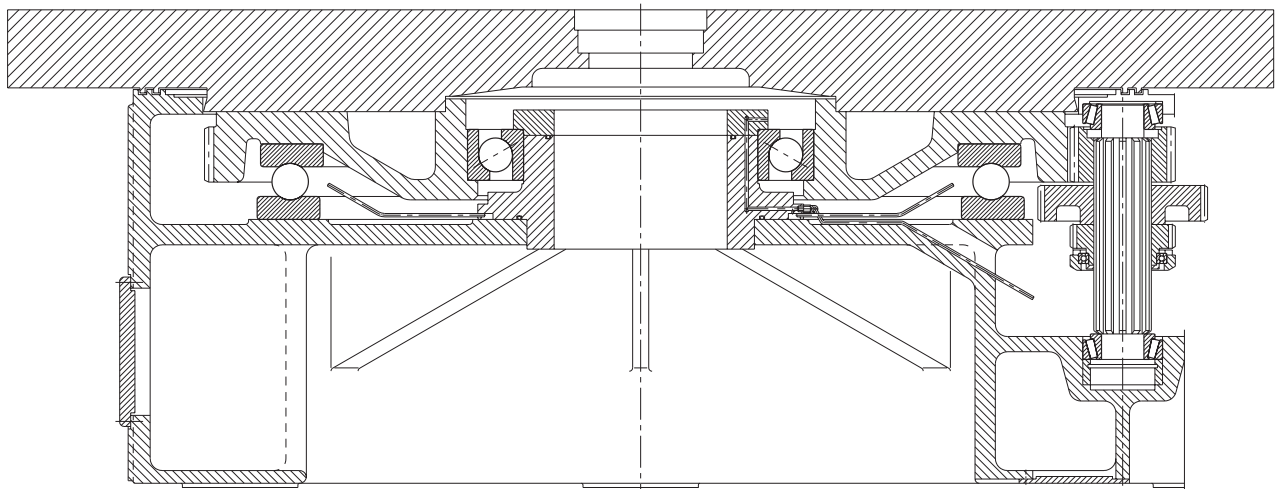

19: Bearing arrangement of a rotary table of a vertical lathe

# 20 Tailstock spindle

## Operating data

Maximum speed  $n = 3,500 \text{ min}^{-1}$

## Bearing selection, dimensioning

The bearing arrangement must be particularly rigid and have a high load carrying capacity. Other requirements such as precision and high-speed suitability are met by bearings of *precision design*.

At the work end the high radial load is accommodated by a double-row cylindrical roller bearing FAG NN3014ASK.M.SP. The high axial load is accommodated at the opposite end by four angular contact ball bearings FAG 7210B.TVP.P5.UL. Three of these bearings are mounted in *tandem arrangement*; the fourth bearing is merely for axial *counter guidance*.

The maximum bearing O.D. is dictated by the size of the quill.

Cylindrical roller bearings have a high radial load carrying capacity, and angular contact ball bearings with a  $40^\circ$  *contact angle* have a high axial load carrying capacity.

## Bearing clearance

The cylindrical roller bearing with a tapered bore is preloaded with  $2...3 \mu\text{m}$  by pressing the inner ring on to the tapered shaft seat (taper 1:12).

The angular contact ball bearings of *universal design* UL have a light preload in the *O arrangement*. The two spacers are identical in width and exclusively serve to provide a cavity which can accommodate the excess *grease* escaping from the bearings.

## Lubrication, sealing

The bearings are lubricated for life with FAG rolling bearing *grease Arcanol/L135V*. A labyrinth *seal* prevents dirt from penetrating into the bearings.

## Machining tolerances

Bearing	Seat	Diameter tolerance	Form tolerance (DIN ISO 1101)	Axial runout tolerance of abutment shoulder
Cylindrical roller bearing	Shaft, tapered	Taper 1:12	$1.5 \mu\text{m}$	$2 \mu\text{m}$
	Housing	$-13 / +2 \mu\text{m}$	$2.5 \mu\text{m}$	$4 \mu\text{m}$
Angular contact ball bearings	Shaft	$-4 / +4 \mu\text{m}$	$1.5 \mu\text{m}$	$2 \mu\text{m}$
	Housing	$-4 / +6 \mu\text{m}$	$2.5 \mu\text{m}$	$4 \mu\text{m}$

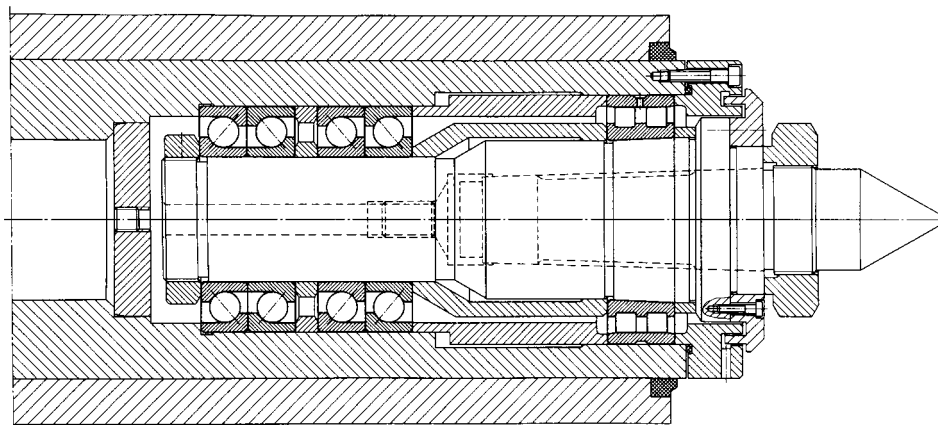

20: Bearing arrangement of a tailstock spindle

# 21 Rough-turning lathe for round bars and pipes

Rough-turning lathes are used for particularly economical production of bars and pipes to tolerance class h9 with a wide range of diameters. In this process, the stationary round stock is moved against rotating lathe tools at a certain feed rate. In this machine four cutting tool carriages are attached to the circumference of the turret head which are radially adjustable.

## Operating data

Input power 75 kW; speed  $n = 300 \dots 3,600 \text{ min}^{-1}$ ; material O.D. 11...85 mm; feed rate 1...40 m/min.

## Bearing selection

The main bearing arrangement is formed by two spindle bearings FAG B7036E.T.P4S.UL and accommodates the cutting forces transmitted by the four cutting tools. The bearings are mounted in *O* arrangement and preloaded with 14.5 kN (2 % of  $C_0/Y_0$ ) by means of springs.

$C_0$  static load rating

$Y_0$  thrust factor (static loading)

Two angular contact ball bearings FAG 71848MP.P5.UL in *O* arrangement accommodate the guiding loads from the axially displaceable hollow cone in which the four tool carriages are radially guided and adjusted.

These bearings are also *adjusted* against each other with a spring preload of 5 kN (1 % of  $C_0/Y_0$ ). Experience shows that with these preloads no slippage damage results, even if the rough-turning lathe is slowed down from  $3,600 \text{ min}^{-1}$  to zero within a second.

## Machining tolerances

The inner rings of both bearings are subjected to *circumferential loads* and are fitted with a tolerance of js5. The bearing seats for the outer rings are machined to G6. The spring preload remains effective in all operating conditions as the expansion of the rotating parts due to the effects of heat and centrifugal force do not cause jamming of the outer rings in the housing.

## Lubrication, sealing

The bearings are lubricated by *oil* injection lubrication with ISO VG 32 ( $32 \text{ mm}^2/\text{s}$  at  $40 \text{ }^\circ\text{C}$ ). At  $80 \text{ }^\circ\text{C}$  the *oil* has an *operating viscosity* of  $\nu = 8 \text{ mm}^2/\text{s}$ .

An elaborate labyrinth *seal* protects the bearings from the ingress of cutting fluid and chips (rubbed-off particles) and from *oil* escape.

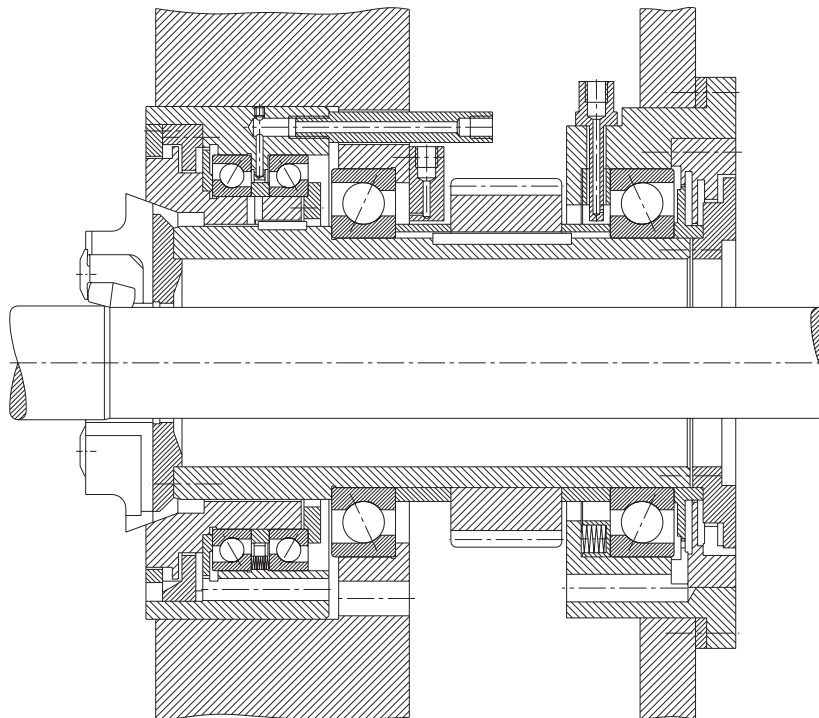

21: Bearing arrangement of a rough-turning lathe for round bars and pipes

---

# 22 Flywheel of a car body press

---

## Operating data

Input power 33 kW; flywheel speed 370 min<sup>-1</sup>; radial load from flywheel weight and belt pull approximately 26 kN.

## Bearing selection

Both rings must be tightly fitted to their mating parts due to the heavy loads and the *circumferential load* on the outer ring. Nevertheless, mounting and dismounting should be simple. These requirements can be met with cylindrical roller bearings. They feature a high load carrying capacity, and they are *separable*, i.e. inner and outer rings can be mounted separately.

The flywheel is supported on the hollow trunnion protruding from the press frame by two cylindrical roller bearings FAG NU1048M1A. The suffix M1A indicates that the bearings are fitted with an outer ring riding *machined* brass cage. Two angle rings HJ1048, one at each of the outer sides of the cylindrical roller bearings, are provided for axial location of the flywheel. Spacer J is arranged between the bearing inner rings and spacer A between the outer rings. Spacer J is 0.6<sup>+0.2</sup> mm longer than spacer A, which ensures adequate *axial clearance*. After the bearing has been mounted, the *axial clearance* is checked (minimum 0.4 mm).

## Bearing dimensioning

The trunnion diameter, which is determined by the design, determines in turn the bearing size.

## Machining tolerances

The outer rings are subjected to *circumferential load* and therefore require tight *fits*; the hub bore is machined to M6. The inner rings are *point-loaded*. The trunnion is machined to j5.

## Bearing clearance

Calculations show that the *radial clearance* is reduced after mounting, due to outer ring contraction and inner ring expansion (probable interference), by only 20 µm from the value measurable prior to mounting (value indicated in table). Bearings of normal *radial clearance* (CN = 110...175 µm) can, therefore, be used.

## Lubrication, sealing

*Grease lubrication* (FAG rolling bearing grease Arcanol L71V).

Shaft *seals* prevent the ingress of dirt.

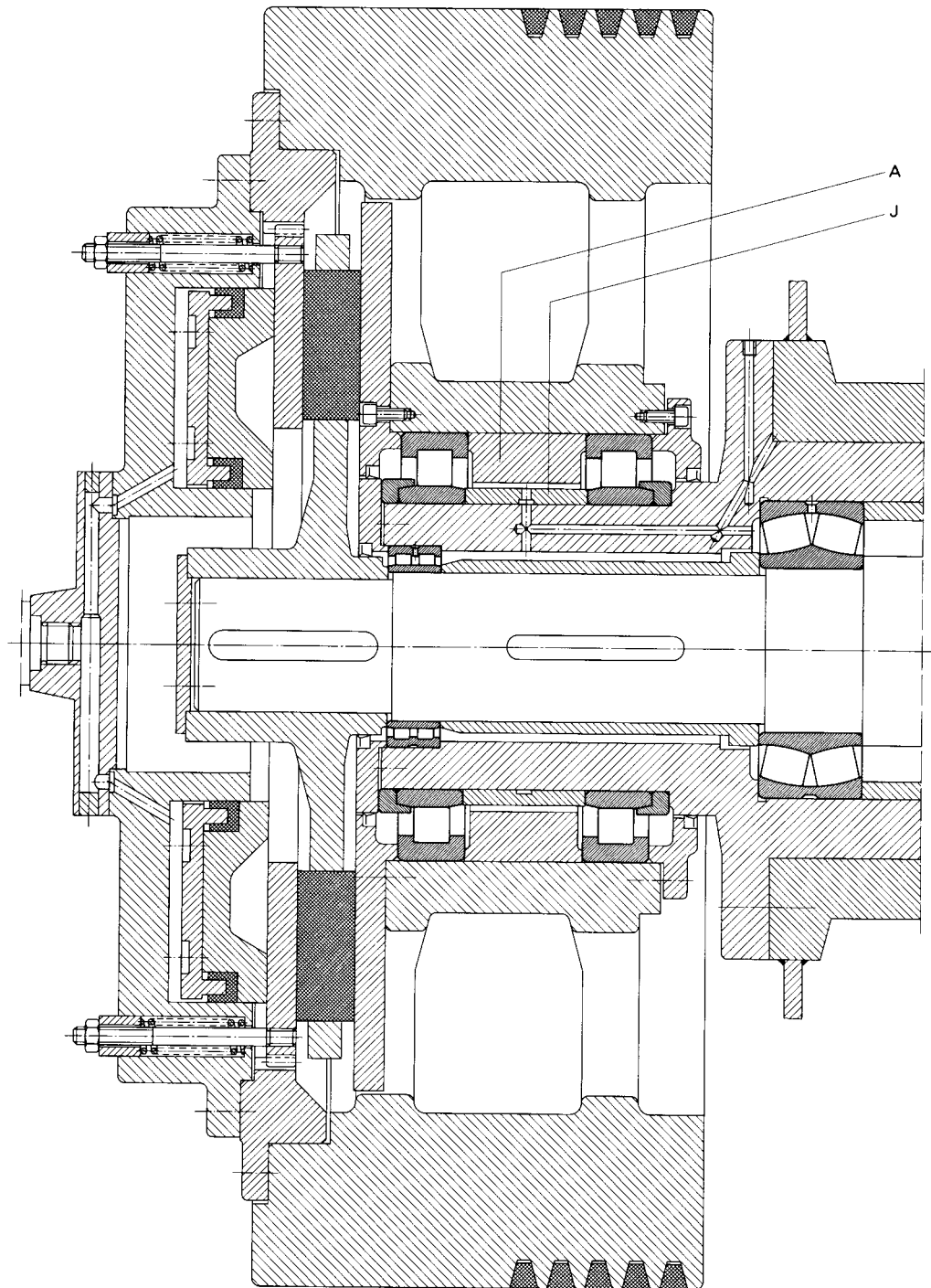

22: Flywheel bearing arrangement of a car body press

# 23 Vertical wood milling spindle

## Operating data

Input power 4 kW; nominal speed 12,000 min<sup>-1</sup>.  
Maximum load on the work end bearing:  
radial – maximum cutting load of 0.9 kN,  
axial – shaft weight and spring preload of 0.2 kN.  
Maximum load on the drive end bearing:  
radial – maximum belt pull of 0.4 kN,  
axial – spring preload of 0.5 kN.

## Bearing selection

Since a simple bearing arrangement is required the bearing is not *oil-lubricated* as is normally the case for such high-speed applications. Experience has shown that *grease lubrication* is effective if deep groove ball bearings of increased precision with textile laminated phenolic resin *cages* are used. Where very high speeds have to be accommodated, angular contact ball bearings with a small *contact angle* (spindle bearings) are often provided. These bearings are interchangeable with deep groove ball bearings and can, therefore, be employed without modifying the spindle design. The work end features a deep groove ball bearing FAG 6210TB.P63 and the drive end a deep groove ball bearing FAG 6208TB.P63. Two Belleville spring washers preload the bearings to 500 N. Clearance-free operation and high rigidity of the spindle system is, therefore, ensured. In addition to this, the spring preload ensures that both bearings are loaded under all operating conditions, thus avoiding ball skidding which may occur in unloaded bearings at high speeds, which in turn may cause roughening of the surfaces (increased running noise).

## Bearing dimensioning

The size of the bearings is dictated by the shaft diameter, which in turn is based on the anticipated vibrations. The bearing sizes thus determined allow a sufficient *bearing life* to be achieved so that a *contamination factor*  $V = 0.5 \dots 0.3$  can be assumed if great care was taken to ensure cleanliness during mounting and maintenance (relubrication). With this very good to utmost cleanliness the bearings even can be failsafe.

## Lubrication, sealing

*Grease lubrication* with FAG rolling bearing grease *Arcanol L74V*. The bearings are packed with *grease* and replenished at the required intervals. In view of the high speeds the grease quantities should not, however, be too large (careful regulation) so that a temperature rise due to working of the grease is avoided.

As a rule, the bearings have to be relubricated every six months, and for high speeds even more often. Non-rubbing labyrinth *seals* are used instead of rubbing-type *seals* in order to avoid generation of additional heat.

## Machining tolerances

Seat	Diameter tolerance	Cylindricity tolerance (DIN ISO 1101)	Axial runout tolerance of the abutment shoulder
Shaft	js5	IT2/2	IT2
Housing (work end)	JS6	IT3/2	IT3
Housing (drive end)	H6	IT3/2	IT3

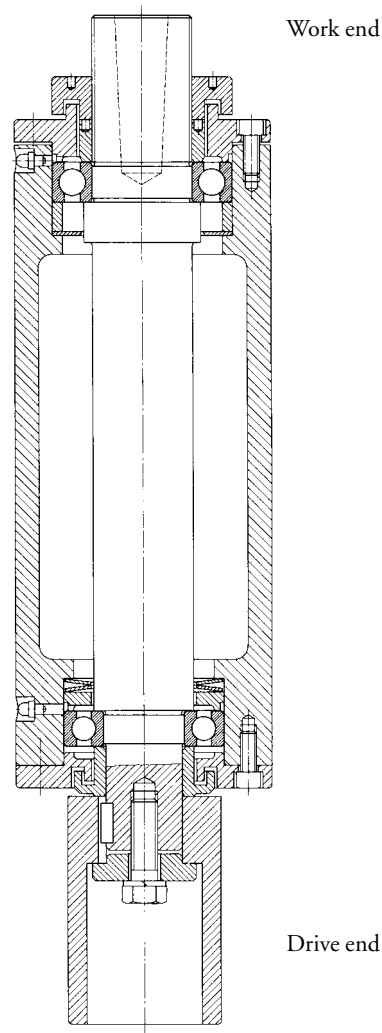

23: Vertical milling cutter spindle

# 24 Double-shaft circular saw

## Operating data

Input power max. 200 kW;  
max. speed 2,940 min<sup>-1</sup>.

## Bearing selection

A simple bearing arrangement is required with standardized bearings which are suitable for very high speeds and allow accurate shaft guidance. The required high shaft rigidity determines the bearing bore diameter.

The *locating bearing* is at the work end in order to keep heat expansion in the axial direction as small as possible at this end. The two spindle bearings FAG B7030E.T.P4S.UL are mounted in *O arrangement*. The bearings of the UL *universal design* are lightly preloaded by clamping the inner rings axially. The bearing pair is suitable for high speeds.

The cylindrical roller bearing FAG NU1026M at the drive end is the *floating bearing*. Heat expansion in the axial direction is freely accommodated in the bearing. The cylindrical roller bearing also accommodates the high belt pull tension forces.

## Machining tolerances

Shaft tolerance js5  
Housing tolerance JS6

## Lubrication, sealing

The bearings are *greased for life*, e.g. with FAG rolling bearing grease *Arcanol L74V*. Good *sealing* is required due to the dust arising during sawing. Non-rubbing *seals* are used due to the high speed. Flinger disks prevent the penetration of coarse contaminants into the gap-type *seals*.

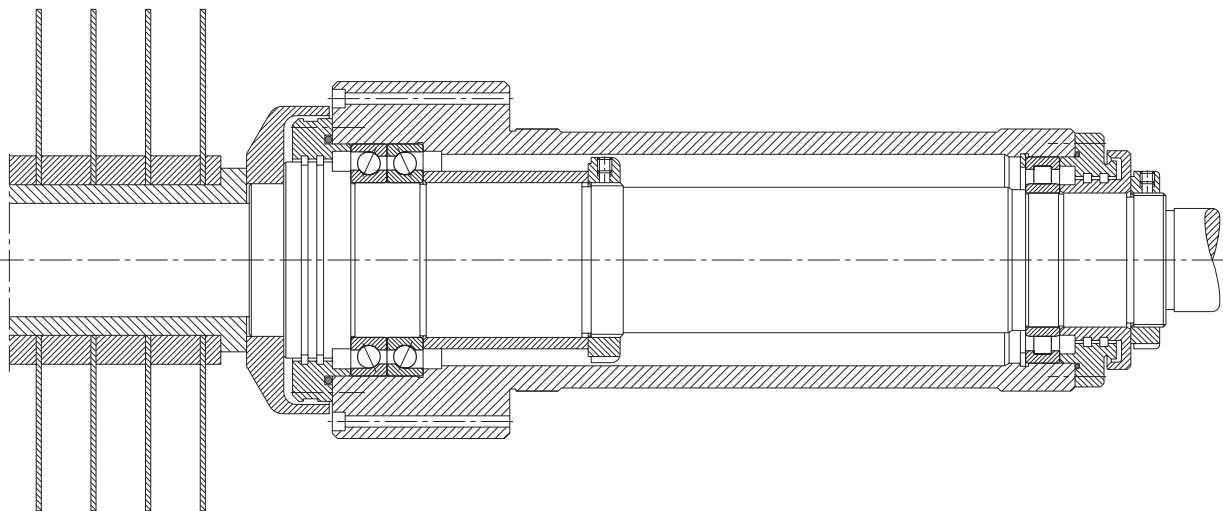

# 25 Rolls for a plastic calender

Plastic foils are produced by means of calenders comprising several rolls made of chilled cast iron or steel with polished surfaces which are stacked on top of each other or arranged side by side.

Hot oil or steam flows through the rolls, heating the O.D.s, depending on the material, to up to 220 °C (rigid PVC), which ensures a good processibility of the material. Rolls 1, 2 and 4 are subjected to deflection under the high loads in the rolling gap. In order to still achieve the thickness tolerances of the sheets in the micrometer range, the deflection is compensated for by inclining of rolls 1 and 3 and by counterbending of rolls 2 and 4. Moreover, the narrow tolerance of the foil thickness requires a high radial runout accuracy of the bearings and adequate radial guidance of roll 3 which is only lightly loaded; this is achieved by preloading the main bearing arrangement by means of collaterally arranged, separate preloading bearings.

## Operating data

Type: four-roll calender, F-shaped

Useful width 3,600 mm

Roll diameter 820 mm

Rolling gap 1st step 1.5...2 mm  
2nd step 1...1.5 mm  
3rd step 0.25...1 mm

Roll speed  $n = 6...24 \text{ min}^{-1}$

Inner ring temperature 170 °C

Roll mass 18 t (weight  $\approx 180 \text{ kN}$ )

## Bearing system

To accommodate the radial and thrust loads, the four rolls are supported at both ends by the same type of main bearing arrangement. It consists of two double-row cylindrical roller bearings forming the *floating bearing* and of two double-row cylindrical roller bearings plus one deep groove ball bearing forming the *locating bearing* at the drive end. In addition, rolls 2 and 4 have to accommodate counterbending forces, and roll 3 has to accommodate preloading forces. These counterbending and preloading forces are supported at both roll ends in spherical roller bearings.

## Bearing selection

### Main bearing arrangement

The radial pressure by load of 1,620 kN resulting from the maximum gap load of 4.5 kN/cm, as well as the counterbending and preloading forces, are accommodated by the main bearing arrangement at each end of rolls 1, 2 and 4. The radial loads and the axial guiding loads are accommodated by double-row FAG cylindri-

## Roll arrangement 1 to 4

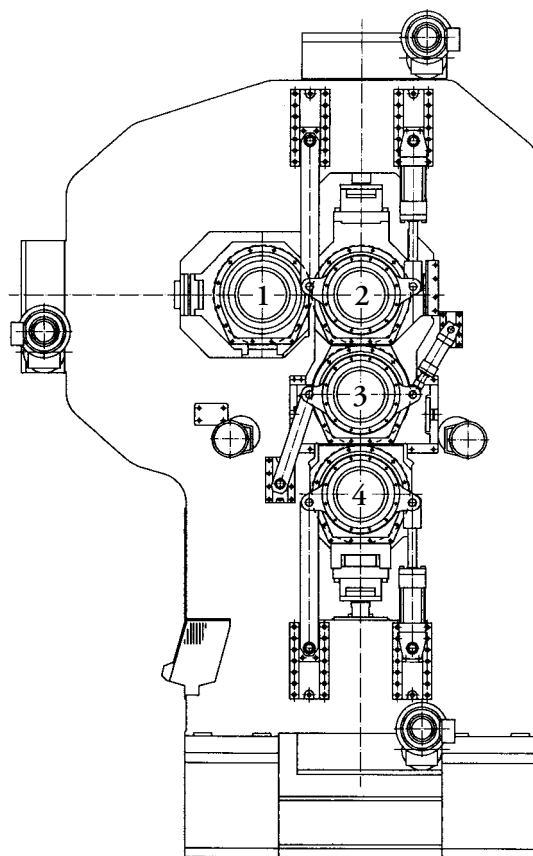

cal roller bearings (dimensions 500 x 650 x 130 mm) and deep groove ball bearings FAG 61996M.P65. At the *locating bearing* end the radially relieved deep groove ball bearing accommodates only axial guiding loads.

At the *floating bearing* end, heat expansions are compensated by cylindrical roller bearings. Misalignments resulting from shaft deflections and roll inclination are compensated for by providing a spherical recess for the bearing housings in the machine frame. The bearings must be dimensionally stable up to 200 °C as their inner rings may heat up to 180 °C as a result of roll heating.

The high radial runout accuracy ( $\leq 5 \mu\text{m}$ ) is achieved by grinding the bearing inner rings and the roll body to finished size in one setting at a roll surface temperature of 220 °C. The inner rings and the roll body can be ground together due to the fact that the inner rings of the cylindrical roller bearings – in contrast to those of spherical or tapered roller bearings – can be easily removed and mounted separately.

The dimension of the inner ring raceway after grinding has been selected such that no detrimental radial preload is generated even during the heating process when the temperature difference between outer and inner ring is about 80 K.

### Rollbending bearings

A counterbending force is generated by means of hydraulic jacks. The counterbending force (max. 345 kN per bearing location) is transmitted to the roll neck by spherical roller bearings FAG 23980BK.MB.C5. The bearings ensure low-friction roll rotation and accommodate misalignments resulting from shaft deflection.

### Preloading bearings

The main bearings of roll 3 have to accommodate the difference from the rolling forces from rolls 2 and 4. In order to avoid uncontrolled radial roll movements, the main bearings are preloaded with 100 kN via spherical roller bearings FAG 23888K.MB.C5.

### Bearing dimensioning

Two cylindrical roller bearings FAG 522028.. mounted side by side have a *dynamic load rating* of  $2 \times 2,160$  kN. The load accommodated by the bearings is calculated, depending on the load direction, from (roll weight + press-on force + counterbending force)/2. The dimensioning calculation is carried out for the most heavily loaded roll 2 which rotates at an average speed of  $15 \text{ min}^{-1}$ .

The *nominal life* is approx. 77,000 hours. Due to the high bearing temperature, the *attainable life*, which takes into account the amount of load, lubricant film

thickness, lubricant *additives*, cleanliness in the lubricating gap and bearing type, is only 42,000 hours. The required *bearing life* of 40,000 h is reached.

### Machining tolerances

Main bearings:	Shaft to r6/housing to H6
Guiding bearing:	Shaft to g6/housing radially relieved
Preloading bearing:	Shaft tapered/ housing H7
Rollbending bearing:	Shaft tapered/ housing to H7

### Lubrication

The bearings are lubricated with *oil*. The lubricant has to meet very stringent requirements. Due to the low speed and the high operating temperature, no elasto-hydrodynamic lubricant film can form. As a result, the bearings always operate in the mixed-friction range and are exposed to the risk of increased *wear*. This condition requires particularly suitable and tested *lubricating oils*.

A central circulation lubrication system with recooling supplies all bearings with *oil*. Holes in the bearing housings, circumferential grooves in the bearing outer rings and in the spacers as well as radial grooves in the outer faces feed the *oil* directly into the bearings. Lip *seals* in the housing covers prevent dirt particles from penetrating into the bearings.

- a Main bearing arrangement (radial), at each end of all rolls:  
2 cylindrical roller bearings
- b Main bearing arrangement (axial), at the drive end of all rolls:  
1 deep groove ball bearing 61996M.P65
- c Preloading bearing arrangement, each end of roll 3:  
1 spherical roller bearing 23888K.MB.C5
- d Rollbending bearing arrangement, each end of rolls 2 and 4:  
1 spherical roller bearing 23980BK.MB.C5

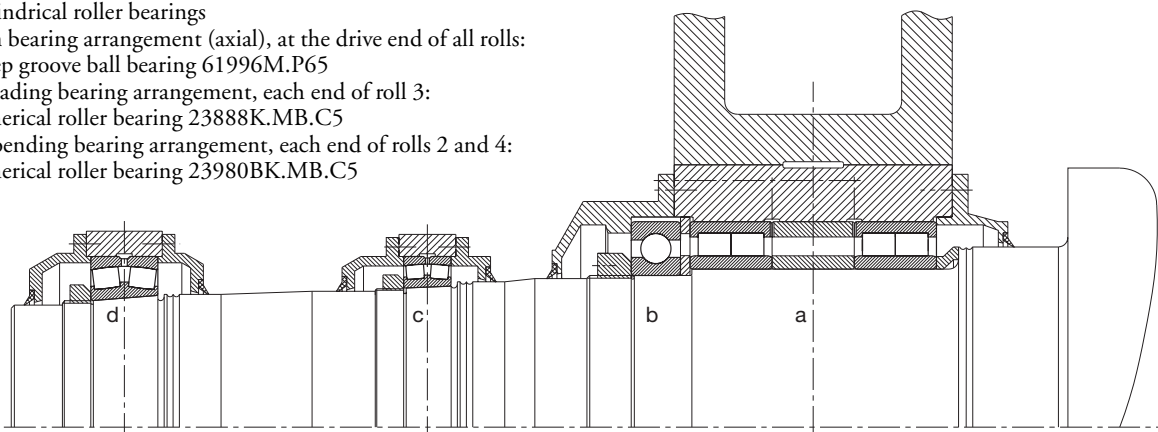

25: Bearing arrangement of a plastic calender

# 26 Infinitely variable gear

The main components of this infinitely variable gear are two shafts linked by a chain which is guided by two bevelled drive disks at each of the shafts. By varying the distance between the bevelled drive disks the running circle of the chain increases or decreases, providing an infinitely variable transmission ratio.

## Bearing selection

The two variator shafts are each supported by two deep groove ball bearings FAG 6306. The driving torque is transmitted by sleeve M via balls to the bevelled disk hub H. The ball contact surfaces of coupling K are wedge-shaped. Thus, sleeve and bevelled disk hub are separated depending on the torque

transmitted, and subsequently the contact pressure between chain and disks is adapted to the torque. Two angular contact thrust ball bearings FAG 751113M.P5 and one thrust ball bearing FAG 51110.P5 accommodate the axial loads resulting from the contact pressure.

Torque variations are associated with small relative movements between shaft and drive disks; for this reason the two parts are separated by needle roller and cage assemblies (dimensions 37 x 45 x 26 mm).

## Lubrication

Oil bath lubrication provides for ample *oil* supply to variator components and bearings.

## Machining tolerances

Bearing	Seat	Diameter tolerance	Cylindricity tolerance (DIN ISO 1101)	Axial runout tolerance of abutment shoulder
Deep groove ball bearing	Shaft	k5	IT3/2	IT3
	Housing	J6	IT3/2	IT3
Angular contact thrust ball bearings and thrust ball bearing	Bevelled disk hubs/ Sleeve	k5	IT2/2	IT2 IT3
Needle roller and cage assembly	Shaft	h5	IT3/2	IT3
	Housing	G6	IT3/2	IT3

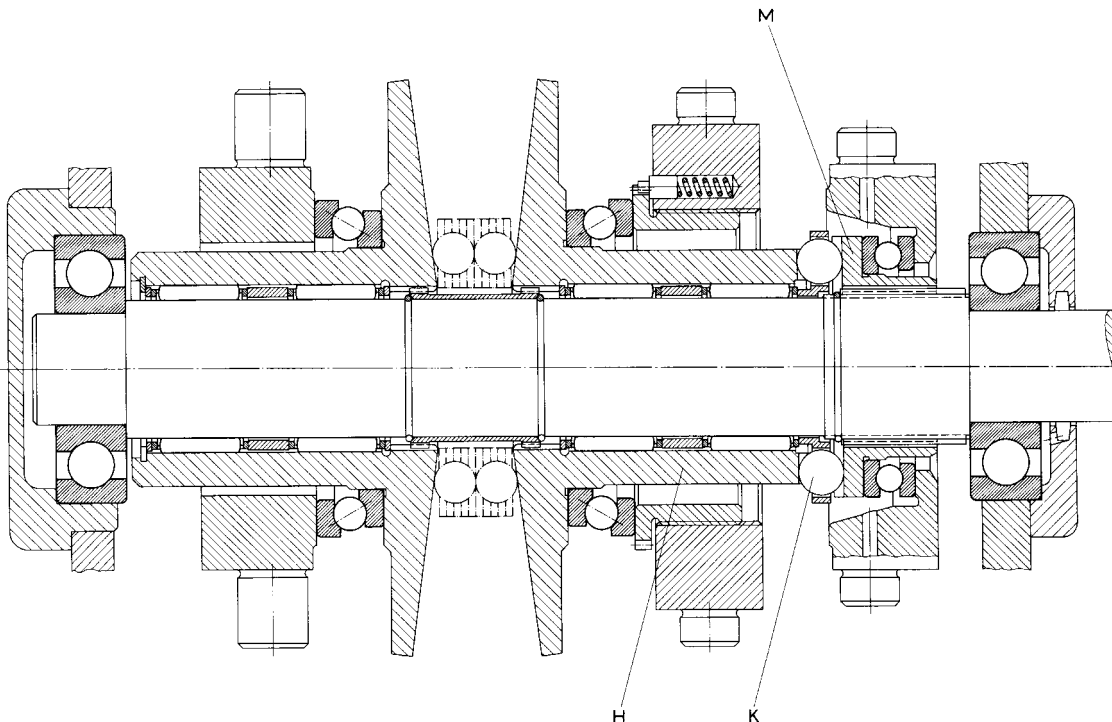

26: Infinitely variable gear

# 27 Spur gear transmission for a reversing rolling stand

## Operating data

The housing contains two three-step transmissions. The drive shafts (1) are at the same level on the outside and the output shafts (4) are stacked in the housing centre.

Input speed 1,000 min<sup>-1</sup>; gear step-up 16.835:1; input power 2 x 3,950 kW.

## Bearing selection

### Input shafts (1)

One cylindrical roller bearing FAG NU2336M.C3 and one four-point bearing FAG QJ336N2MPA.C3 form the *locating bearing*. The *floating bearing* is a cylindrical roller bearing FAG NJ2336M.C3. The four-point bearing is mounted with clearance in the housing (relieved) and, therefore, takes up just the axial loads. The two cylindrical roller bearings only take up the radial loads.

### Intermediate shafts (2, 3)

The intermediate shafts have a *floating bearing* arrangement with FAG spherical roller bearings: 22348MB.C3 and 24160B.C3 for shafts 2. 23280B.MB and 24164MB for shafts 3.

### Output shafts (4)

A spherical roller bearing FAG 24096B.MB is used as *locating bearing*. A full-complement single-row cylindrical roller bearing as a *floating bearing* compensates for the thermal length variations of the shaft.

## Machining tolerances

### Input shafts (1):

Cylindrical roller bearing: – Shaft n6; housing J6

Four-point bearing: – Shaft n6; housing H7

### Intermediate shafts (2 and 3):

Spherical roller bearing: – Shaft n6; housing relief-turned.

### Output shafts (4):

Cylindrical roller bearing: – Shaft p6; housing JS6

Spherical roller bearing: – Shaft n6; housing JS6

## Lubrication

The bearings are also connected to the *oil* circulation system for the transmission wheels. The *oil* (ISO VG320) is fed directly to the bearing positions from the oil filter.

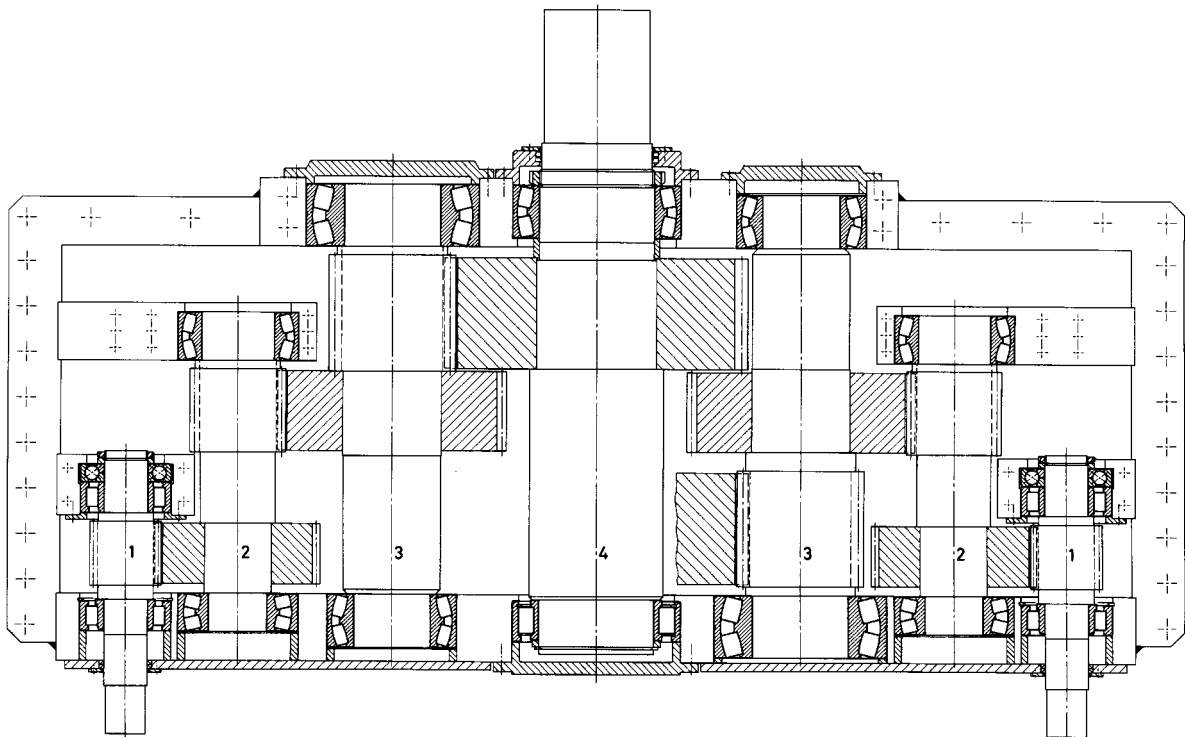

27: Spur gear transmission for a reversing rolling stand

# 28 Marine reduction gear

The hardened and ground gearings of marine gears transmit great torques.

## Operating data

Input power  $P = 5,475$  kW; input speed  $750$  min<sup>-1</sup>; output speed  $209$  min<sup>-1</sup>; operating temperature ca.  $50$  °C.

## Bearing selection

### Coupling shaft

The coupling shaft (upper right) is supported at the drive end by a spherical roller bearing 23248B.MB (*locating bearing*) and at the opposite end by a cylindrical roller bearing NU1056M (*floating bearing*). The shaft transmits only the torque. The bearings have to accommodate only the slight deadweights and minor gearwheel forces from a power take-off system. The bearing dimensions are determined by the design; as a result larger bearings are used than needed to accommodate the loads. Consequently, a *life* calculation is not required.

### Input shaft

At the input shaft the radial loads from the gearing are accommodated by two spherical roller bearings 23248B.MB. The thrust loads in the main sense of rotation during headway operation are separately accommodated by a spherical roller thrust bearing 29434E. The bearing 23248B.MB on the left side also accom-

modates the smaller axial loads in the opposite direction. It is *adjusted* against the spherical roller thrust bearing with a slight clearance and preloaded by springs. The preload ensures that the *thrust bearing* rollers do not lift off the raceways when the load changes but keep rolling without slippage. The housing washer of the spherical roller thrust bearing is not radially supported in the housing to ensure that this bearing can transmit no radial loads.

### Output shaft

At the output shaft, radial and axial loads are accommodated separately. The radial loads are accommodated by two spherical roller bearings 23068MB. In the *locating bearing* position at the output end a spherical roller thrust bearing 29464E accommodates the difference from the propeller thrust during headway operation and the axial tooth loads. The smaller axial loads during sternway operation are taken up by the smaller spherical roller thrust bearing 29364E. These two thrust bearings are also *adjusted* against each other with a slight *axial clearance*, preloaded by springs and not radially supported in the housing.

## Bearing dimensioning

Based on the operating data, the following *nominal fatigue lives* are obtained for the different bearings. The minimum value of  $L_h = 40,000$  hours required for classification was not only reached but far exceeded.

Shaft	Bearing location	Rolling bearing	Equivalent dynamic load $P$ [kN]	Index of dynamic stressing $f_L$	Nominal fatigue life $L_h$ [h]	Viscosity ratio $\nu/\nu_1$	Factor $a_{23} = a_{23II} \cdot s$	Attainable life at utmost cleanliness $L_{hna}$ [h]
<b>Coupling shaft</b>								
<i>Locating bearing</i>	1	23248B.MB	only slightly loaded by deadweight					
<i>Floating bearing</i>	2	NU1056M	only slightly loaded by deadweight					
<b>Input shaft</b>								
<i>Radial bearings</i>	3	23248B.MB	242	3.98	49,900	6.3	>114	»200,000
	3 new	23048B.MB	242	1.88	4,100	5.8	>114	»200,000
	4	23248B.MB	186	5.18	120,000	6.3	>114	»200,000
<i>Thrust bearings</i>	5	29434E	80	>6.03	>200,000	5.2	>114	»200,000
	5 new	29334E	80	4.91	102,000	5.0	>114	»200,000
<b>Output shaft</b>								
<i>Radial bearings</i>	6	23068MB	158	>6.03	>200,000	2.4	>84	»200,000
	7	23068MB	293	4.64	83,500	2.4	>84	»200,000
	7 new	23968MB	293	2.70	13,600	2.3	39	»200,000
<i>Thrust bearings</i>	8	29364E	only briefly loaded during sternway operation					
	9	29464E	650	3.81	43,300	2.5	> 87	»200,000
	9 new	29364E	650	2.35	8,600	2.3	> 84	»200,000

The effects of basing the bearing dimensions on *attainable life* become evident in the case of the two bearings dimensioned for the least load carrying capacity: the spherical roller bearing 23248B.MB (bearing location 3) at the coupling end of the input shaft and the spherical roller thrust bearing 29464E (bearing location 9) at the output end of the output shaft.

Based on the *index of dynamic stressing*  $f_L$  a *nominal life*  $L_h = 49,900$  h is calculated for spherical roller bearing 3 and  $L_h = 43,300$  h for spherical roller thrust bearing 9. Due to the required minimum *life* of 40,000 h the transmission bearings would thus be sufficiently dimensioned.

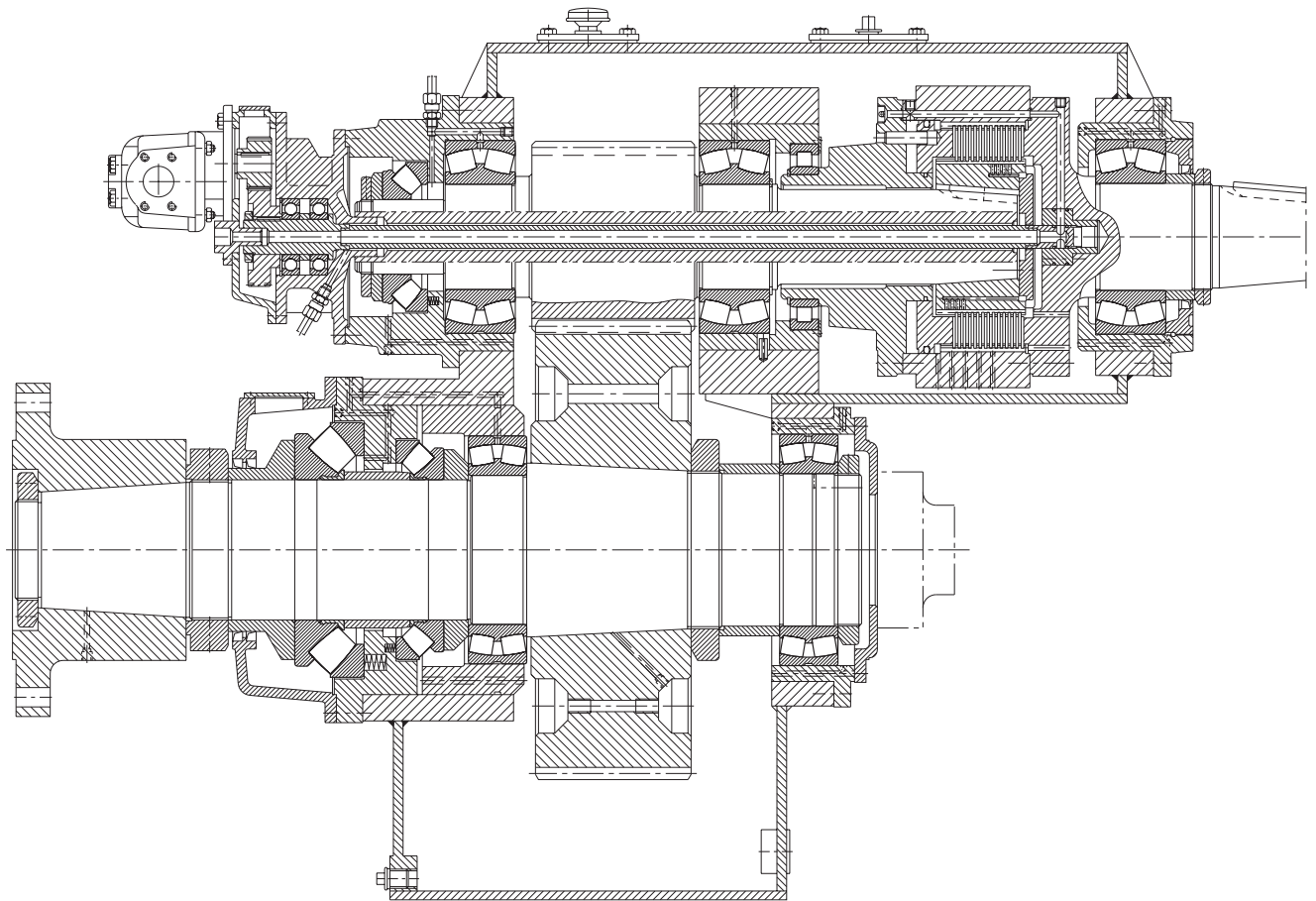

28: Bearing arrangement of a marine gear

## Attainable life

The actually *attainable life*  $L_{\text{hna}}$  is considerably longer than the *nominal life*  $L_{\text{h}}$ .

$L_{\text{hna}} = a_1 \cdot a_{23} \cdot L_{\text{h}}$  is calculated with the following data:

Nominal *viscosity* of the *oil*:  $\nu_{40} = 100 \text{ mm}^2/\text{s}$

Operating temperature:  $t = 50 \text{ }^\circ\text{C}$

Operating *viscosity*:  $\nu = 58 \text{ mm}^2/\text{s}$

Spherical roller bearing 23248B (no. 3):

$C = 2,450 \text{ kN}$ ;  $C_0 = 4,250 \text{ kN}$ ;  $n = 750 \text{ min}^{-1}$ ;

$d_{\text{m}} = (440 + 240)/2 = 340 \text{ mm}$

Rated *viscosity*:  $\nu_1 = 9.2 \text{ mm}^2/\text{s}$

*Viscosity ratio*:  $\nu/\nu_1 = 6.3$

Spherical roller thrust bearing 29464E (no. 9):

$C = 4,300 \text{ kN}$ ;  $C_0 = 15,600 \text{ kN}$ ;  $n = 209 \text{ min}^{-1}$ ;

$d_{\text{m}} = (580 + 320)/2 = 450 \text{ mm}$

Rated *viscosity*:  $\nu_1 = 23 \text{ mm}^2/\text{s}$

*Viscosity ratio*:  $\kappa = \nu/\nu_1 = 2.5$

A *stress index*  $f_{\text{s}^*} = C_0/P_{0^*} > 14$  is obtained for both bearings; consequently,  $K_1 = 1$  and  $K_2 = 1$ ; therefore,  $K = 1 + 1 = 2$ .

From the *viscosity ratio*  $\kappa$  and the *factor*  $K$  the following *basic factors* are obtained:

- for the radial spherical roller bearing  $a_{23\text{II}} = 3.8$
- for the spherical roller thrust bearing  $a_{23\text{II}} = 2.9$

*Factor*  $a_{23}$  is obtained from  $a_{23} = a_{23\text{II}} \cdot s$ .

The *cleanliness factor*  $s$  is determined on the basis of the *contamination factor*  $V$ . Both bearings operate under utmost cleanliness conditions ( $V = 0.3$ ). Cleanliness is utmost if the particle sizes and filtration ratios of *contamination factor*  $V = 0.3$  are not exceeded.

Taking into account the *viscosity ratio*  $\kappa$  and the *stress index*  $f_{\text{s}^*}$ , a *cleanliness factor* of  $s > 30$  and consequently an  $a_{23}$  *factor* =  $a_{23\text{II}} \cdot s > 114$  and  $> 87$ , respectively, is obtained for the bearings under consideration. The *attainable life* is in the *endurance strength* range.

This means that smaller bearings could be provided for bearing locations 3, 5, 7 and 9 to accommodate the same shaft diameter (see table: 3 new, 5 new, 7 new, 9 new) and would, in spite of the now higher bearing loads, still be in the *endurance strength* range.

## Machining tolerances

As all bearing inner rings in this application are subjected to *circumferential load* they are fitted tightly onto the shaft seats:

- *Radial bearings* to n6
- *Thrust bearings* to k6.

If the *radial bearing* outer rings are subjected to *point load*, the bearing seats in the housings are machined to H7.

As the spherical roller thrust bearings are to accommodate exclusively thrust loads they are fitted with clearance, i.e. radially relieved, into the housing seats which are machined to E8.

## Lubrication, sealing

To meet the high requirements on safety and reliability, adequate lubrication and cleanliness conditions are provided for marine gears. The circulating *oil*/ISO VG 100, which is used to lubricate both gear wheels and rolling bearings, is cooled and directly fed to the bearings. By-pass filters with filter condition indicators and with an adequate filtration ratio ensure an oil condition where no particles bigger than  $75 \mu\text{m}$  are found and where, consequently, cleanliness is usually utmost (*contamination factor*  $V = 0.3$ ).

For this reason, the *oil* cleanliness class should be 14/11 or 15/12 (ISO 4406).

Radial shaft *seals* protect the transmission from contamination.

# 29 Bevel gear – spur gear transmission

## Operating data

Input speed 1,000 min<sup>-1</sup>; gear ratio 6.25:1; input power 135 kW.

## Bearing selection, dimensioning

### Pinion shaft

The pinion is an overhung arrangement. Two tapered roller bearings FAG 31315.A100.140.N11CA in *X* arrangement are mounted at the *locating end*. Spacer A between the cups adjusts the bearing pair to achieve an *axial clearance* of 100...140 µm prior to mounting.

The *floating bearing*, a cylindrical roller bearing FAG NUP2315E.TVP2, has a tight *fit* on the shaft and a slide *fit* in the housing.

Axial pinion adjustment is achieved by grinding the spacers B and C to suitable width.

### Crown wheel shaft

The crown wheel shaft is supported by two tapered roller bearings FAG 30320A (T2GB100 - DIN ISO 355). The bearings are mounted in *X* arrangement and are *adjusted* through the cups. For axial adjustment and adjustment of the *axial clearance* the spacers D and E are ground to suitable width.

### Output shaft

The output shaft is supported by two spherical roller bearings FAG 23028ES.TVPB in *floating bearing* arrangement.

Detrimental axial preloads are avoided by means of a gap between the covers and outer rings.

For the *floating bearing* of the pinion shaft an *index of dynamic stressing*  $f_L = 2.88$  is calculated. This value corresponds to a *nominal life* of  $L_h = 17,000$  hours. Taking into account the operating conditions such as:

- oil ISO VG220 with suitable *additives*,
  - a good degree of cleanliness in the lubricating gap,
  - max. operating temperature 80 °C,
- a factor  $a_{23} = 3$  is obtained with the *adjusted life calculation*. Therefore, the *attainable life*  $L_{hna} = 50,700$  hours.

## Machining tolerances

The bearing inner rings are subjected to *circumferential loads* and consequently have to be fitted tightly on the shaft. The bearing seats for the pinion bearings must be machined to the following tolerances: Shaft to m5 / housing to H6.

## Lubrication, sealing

All bearings are sufficiently lubricated with the splash *oil* from the gears. The tapered roller bearing pair is supplied with *oil* which is fed through ducts from collecting pockets in the upper housing part. Shaft *seals* are fitted at the shaft openings.

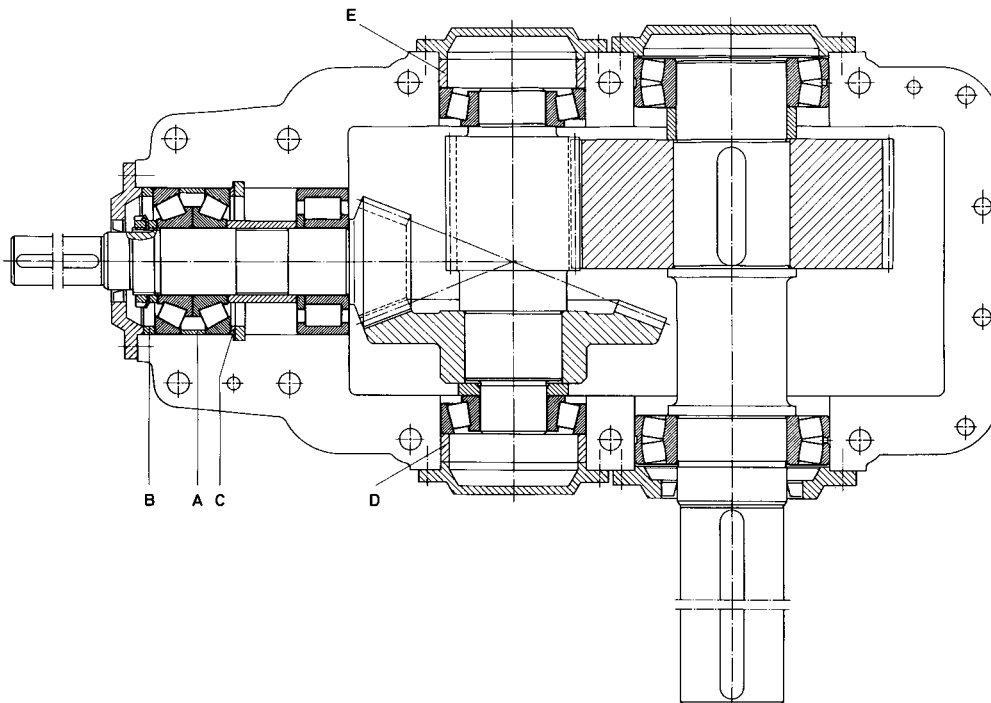

# 30 Double-step spur gear

## Operating data

Max. input speed 1,500 min<sup>-1</sup>; gear ratio 6.25:1; output power 1,100 kW at a maximum speed of 1,500 min<sup>-1</sup>.

## Bearing selection

The bearings supporting the three gear shafts are *adjusted*. Two tapered roller bearings FAG 32224A (T4FD120)\*, two tapered roller bearings FAG 30330A (T2GB150)\* and two tapered roller bearings FAG 30336 are used. The *X arrangement* chosen means that the cups are adjusted and the adjusting shims inserted between the cup and housing cover determine the *axial clearance*. The same gear housing is also used for gears transmitting higher power. In such a case larger bearings are used without sleeves.

## Machining tolerances

The cones are subjected to *circumferential load* and are, therefore, fitted tightly on the shaft. The cups are subjected to *point load* and can, therefore, have a loose *fit*. The bearing seats on the shafts are machined to m6, the housings to J7.

The relatively loose *fit* in the housing simplifies cup *adjustment*.

## Lubrication, cooling, sealing

The lubrication system selected depends on the gear speed, power, operating time and ambient temperature. For low power and low gear circumferential speeds, *oil splash* lubrication without extra cooling is sufficient. Medium power often requires some extra cooling. For high power and high gear circumferential speeds circulating *oil* lubrication (possibly with oil cooler) is provided. Detailed information on the range of application of lubrication system and *oils* in question is available from gear manufacturers.

The rolling bearings are lubricated with the same *oil* as the gears; for this purpose baffle plates and collecting grooves are provided in the transmission case to trap the oil and feed it through the channels to the bearings.

Gap-type *seals* with grooves and oil return channels in the end covers provide adequate *sealing* at the shaft openings. More sophisticated *seals* such as shaft *seals* (with dust lip, if necessary) are provided where ambient conditions are adverse.

\*) Designation according to DIN ISO 355

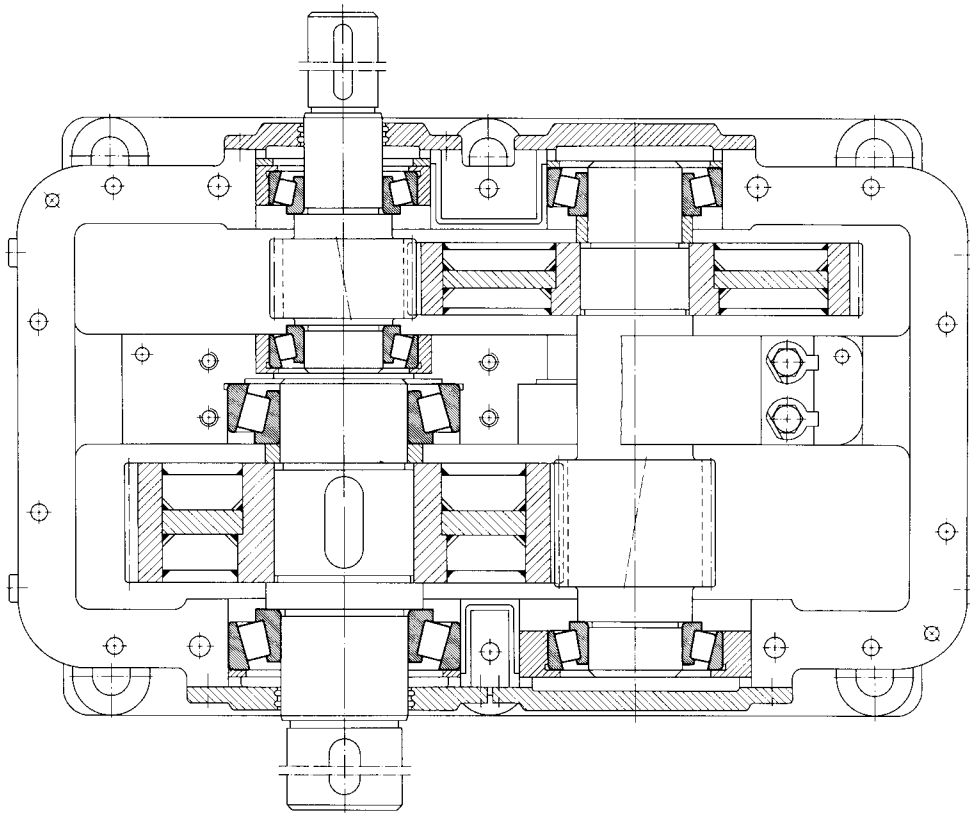

30: Double-step spur gear

# 31 Worm gear pair

## Operating data

Input power 3.7 kW; input speed 1,500 min<sup>-1</sup>; overall gear ratio 50:1.

## Bearing selection

### Worm shaft

The worm shaft bearings are primarily axially loaded, the load direction changing with the direction of rotation of the worm. The radial loads acting on the bearings are relatively small. A *locating-flating bearing arrangement* is selected.

The *locating bearing* comprises two universal angular contact ball bearings FAG 7310B.TVP.UA. Suffix UA indicates that the bearings can be mounted in any *tandem*, *O* or *X* arrangement. When the bearings are paired in *O* or *X* arrangement and the shaft is machined to j5 and the housing to J6, the bearings feature a small *clearance*. The two angular contact ball bearings are mounted in *X* arrangement. Depending on the direction of rotation of the worm shaft, either one or the other bearing accommodates the axial load.

A cylindrical roller bearing FAG NU309E.TVP2 is mounted as the *floating bearing*.

### Worm gear shaft

The bearings of the worm gear shaft are mainly radially loaded; the axial loads are relatively low in comparison. A deep groove ball bearing FAG 6218 is therefore provided at the *locating bearing* end and a cylindrical roller bearing FAG NU218E.TVP2 at the *floating bearing* end.

## Machining tolerances

Angular contact ball bearings: Shaft to j5; housing to J6  
Cylindrical roller bearings: Shaft to k5; housing to J6  
Deep groove ball bearing: Shaft to k5; housing to K6

## Lubrication, sealing

The worm gear and the bearings are *oil*-lubricated. The *oil* level should coincide with the lowest point of the worm teeth pitch circle diameter. The *sealing* rings at the shaft openings prevent oil from escaping and offer adequate protection against contamination.

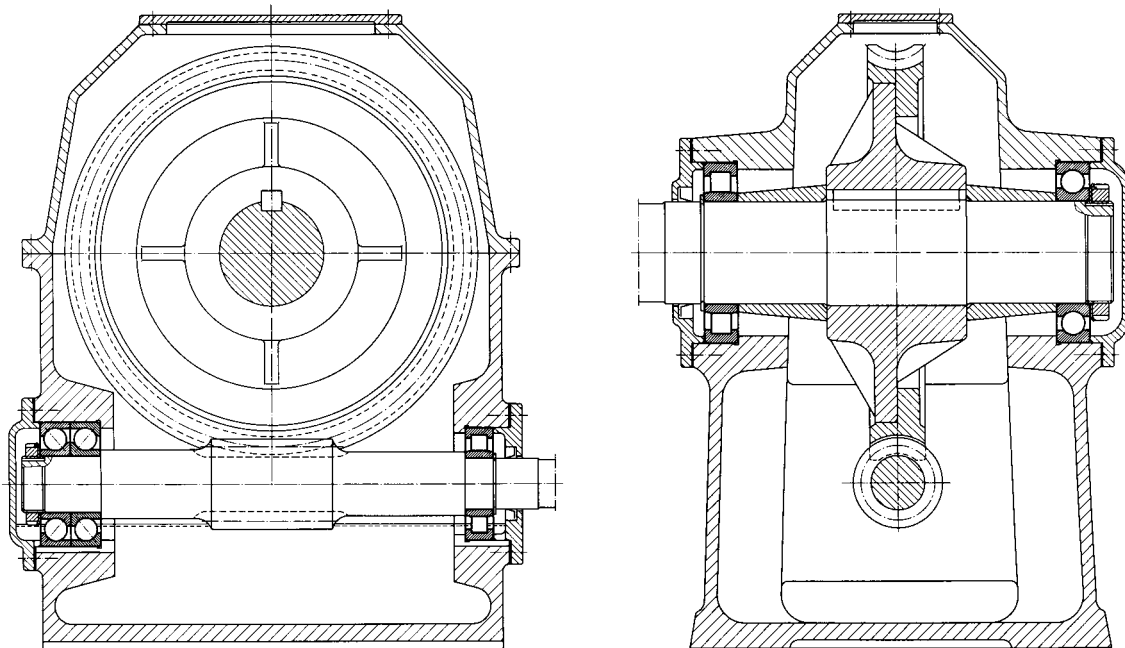

## Design

The rolling bearings used in torque converters in vehicles (manual transmissions and transfer boxes) are custom-tailored to this application. Depending on the load accommodation and speed requirements, deep groove ball bearings – both unshielded and dirt-protected ("clean bearings") –, cylindrical roller bearings, combined bearings and tapered roller bearings have proven themselves in the main bearing locations. The idlers are generally supported on needle roller and cage assemblies. The main bearing locations have *locating-floating* bearing designs, *adjusted* bearing or *floating bearing arrangements*.

### *Locating-floating bearing arrangement*

Radial loads are accommodated by both bearings while the axial load is taken up by the *locating bearing*. With extreme axial loads the radial and axial loads may be taken up separately (*axial bearing* e. g. deep groove ball bearing or four-point bearing) at the *locating bearing* end.

### *Adjusted bearing arrangement*

The angular contact ball bearings or tapered roller bearings are mounted in opposition to one another. The bearings, when running at operating temperature, should have zero clearance or even preload (narrow axial guidance). Regulation of the *axial clearance* by axial displacement of the bearing rings. Both bearings accommodate radial and axial loads.

### *Floating bearing arrangement*

The bearings (except for *angular contact bearings*, all bearing types may be used) accommodate both radial and axial loads, permitting, however, axial displacement of the shaft. This axial displaceability is such that the bearings are never preloaded, not even under adverse thermal conditions.

## Lubrication

The gear wheels of vehicle transmissions are all *oil*-lubricated almost without exception. For this reason *oil lubrication* is usually also provided for the rolling bearings in the transmission. Since the rolling bearings require only very little lubricant, the *oil* splashed from the gear wheels is normally sufficient for bearing lubrication. Only in cases where the splash oil does not reach the bearings may it be necessary to provide collecting pockets and feed ducts. On the other hand it is advisable to protect those bearings which run directly beside the gear wheel from excessive *oil* supply, for example by means of a *seal* or a baffle plate.

However, with joint lubrication of gear wheels and bearings care must be taken that the *life*-reducing contaminants are filtered out of the *oil* circulation (costly).

## Dirt-protected bearings

In order to keep these contaminants (rubbed-off particles from the gears) out of the bearings as long as possible, manual transmissions for cars are fitted today with sealed, *grease*-lubricated deep groove ball bearings or angular contact ball bearings (so-called dirt-protected or "clean bearings").

Since roller bearings are less affected by cycled particles, the dirt-protected design is not required in automotive gearboxes.

## Bearing selection and dimensioning

The bearing calculation is based on the maximum input torque with the corresponding speed, the gearing data and the proportionate running times for the individual gear steps.

### Determination of the tooth loads

Based on the tangential load  $F_t = M_d / r$  a radial load ( $F_r = F_t \cdot \tan \alpha_E$ ) and an axial load ( $F_a = F_t \cdot \tan \beta$ ) are calculated. Based on the distances at the individual shafts, the forces acting on the teeth are distributed over the individual bearing locations, also taking into account the tilting moment caused by the tooth load component  $F_a$ .

### Index of dynamic stressing $f_L$

Unsealed transmission bearings in medium-weight to heavy cars should have an  $f_{Lm}$  value of 1.0...1.3, where as the  $f_{Lm}$  value for dirt-protected bearings should be 0.7...1.0.

The bearing loads in the individual speeds and the transmission bearings are calculated in detail by means of computer programs.

### Attainable life

The lubricant in open ball bearings must be assumed to be moderately (*contamination factor*  $V = 2$ ) to heavily contaminated ( $V = 3$ ).

With the usual transmission bearing *stress indexes* of  $f_{s*} \approx 2...8$ , depending on the gear, a *cleanliness factor* of  $s = 0.6...0.7$  is obtained with  $V = 2$ , and  $s = 0.3...0.5$  with  $V = 3$ .

Consequently, due to the effects of contamination by the transmission *oil*, the reserve capacities of the unsealed ball bearings (higher  $f_{Lm}$  value) cannot be utilized. On the other hand, if dirt-protected ball bearings are used,

---

at least normal cleanliness (*contamination factor*  $V = 1$ ), in most cases improved cleanliness ( $V = 0.5$ ) or even utmost cleanliness ( $V = 0.3$ ) can be achieved. Thus, with a *viscosity ratio* of  $\kappa = 1$ , a *cleanliness factor*  $s$  is obtained which is between 1 and 3.

So dirt-protected transmission bearings (deep groove ball bearings or angular contact ball bearings) reach *lives* which are up to six times longer than those of unsealed bearings running in the "contaminated" transmission *oil*.

### **Machining tolerances**

At all bearing locations the inner rings are subjected to *circumferential load* and the outer rings to *point load*. The bearing seats on the shafts are machined to j6...m6 and those in the housings to M6...P6 (light metal) and to J6...K6 (grey-cast iron), respectively. The tighter bearing *fits* in light-metal housings take into account the differences in the thermal expansion of light metal and steel.

# 32 Passenger car transmission

## Operating data

Five-speed transmission for passenger cars for a maximum input torque of 170 N m at 4,500 min<sup>-1</sup>; the 5th speed is an overdrive gear; light-metal housing. Gear ratios: 3.717 – 2.019 – 1.316 – 1.0 – 0.804

## Bearing selection

### Input shaft

Combined bearings (deep groove ball bearing + roller and cage assembly) as *locating bearing* for accommodating radial and axial loads. The roller and cage assembly runs directly on the input shaft. The outer ring is axially located via the housing cover in pull operation and via a snap ring in push operation.

### Lay shaft

*Floating bearing arrangement* with roller sleeves. The *axial clearance* is adjusted by means of fitting washers at the roller sleeve of the input end. Axial location is provided by a snap ring. The transmission is *sealed* to prevent *oil* escape. There is an opening at the closed end of the output-side roller sleeve to facilitate dismounting.

### Output shaft

#### Engine-end bearing:

The roller and cage assembly runs directly on the output shaft and in the bore of the input shaft. The *cage* is

guided by the *rolling elements*. The logarithmic profile of the rollers is especially adapted to the stress resulting from shaft deflection. Lubricating holes in the gear wheel of the input shaft provide for a better *oil* supply to the roller and cage assembly.

### Output end:

Deep groove ball bearing as *locating bearing*, axial location of the outer ring by means of the housing shoulder and retaining washer. The idlers on the output shaft are directly supported by double-row needle-roller-and-cage assemblies.

## Machining tolerances

Bearing location	Tolerance	
	Shaft	Housing
Input shaft	k6	N6
Direct bearing arrangement roller and cage assembly	g6	
Lay shaft		
Drive end/output end	h5	N6
Output shaft		
Engine-end bearing	g6	G6
Output end	k6	N6
Idlers (1st – 5th gear, reverse gear)	h5	G6

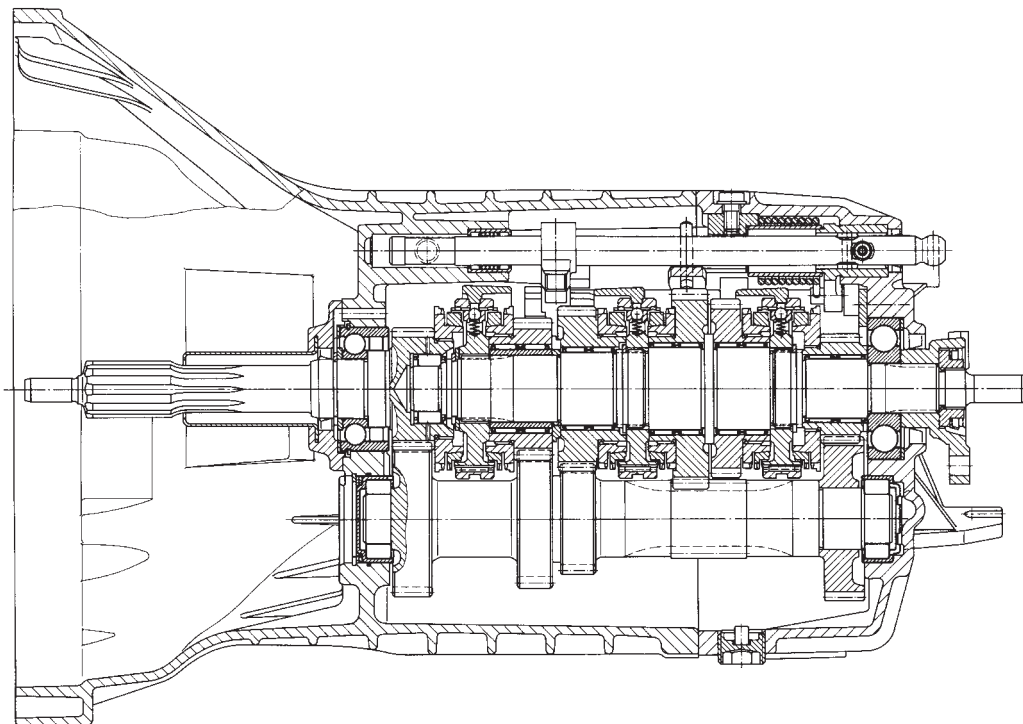

32: Passenger car transmission

# 33 Manual gearbox for trucks

## Operating data

16-speed-transmission for heavy trucks in the power range from 220 to 370 kW. The 4-speed component is extended to 16 gears by means of a split group and a range group.

Gear ratios: 13.8 — 0.84 and 16.47 — 1.0.

## Bearing selection

### *Input and output shafts, main bearings*

Adjusted tapered roller bearings in boxed *X* arrangement. Adjustment of these bearings via the cup of the tapered roller bearing at the input end. The cup is machined to K6.

### *Lay shaft*

Tapered roller bearings in *X* arrangement; machining tolerances: shaft to k6 / housing to K6.

The idler gears are supported by needle-roller-and-cage assemblies.

### *First split constant*

Bearing arrangement with two single-row needle-roller-and-cage assemblies. Shaft tolerance g5; housing tolerance G5.

### *Second split constant*

Bearing arrangement with two cylindrical roller bearings, both outer ring raceways integrated in the gear-wheel bore. The cylindrical roller bearings accommodate radial and axial loads.

### *Range group*

The planet wheels are supported by full-complement, double-row cylindrical roller bearings.

The lubricant is supplied via bores between the roller rows and collecting pockets in the cage. A deep groove ball bearing supports the cage versus the ring gear.

At the output end of the output shaft a deep groove ball bearing accommodates the radial and axial loads resulting from the joint shaft.

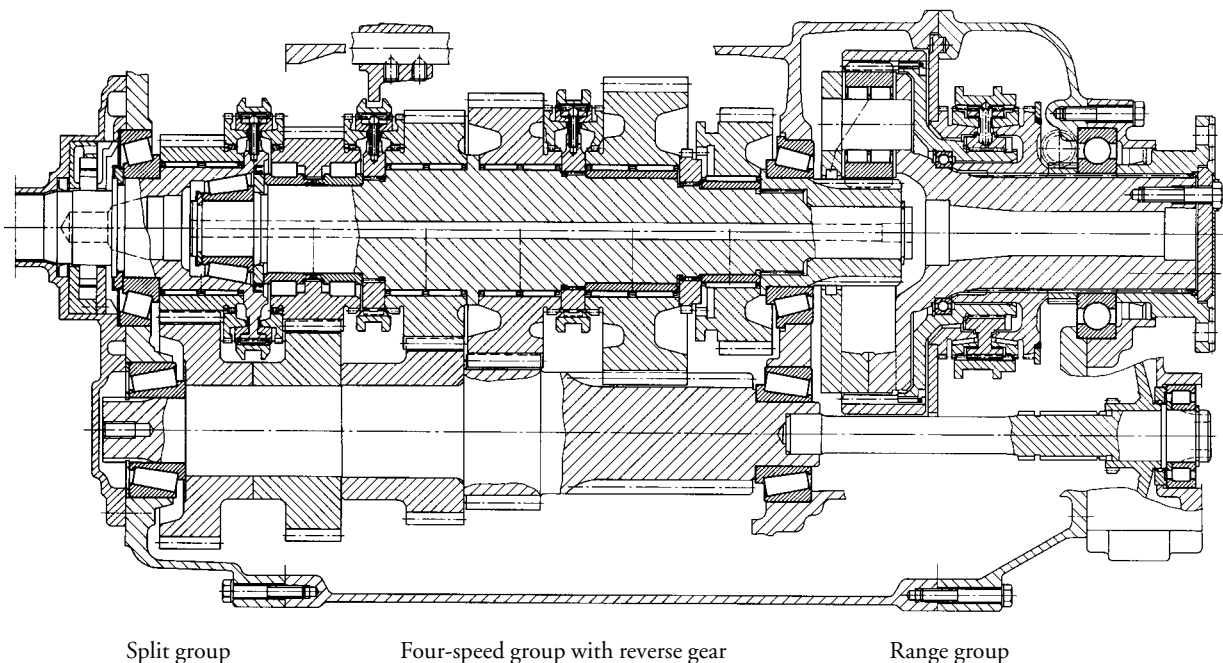

---

# Automotive differentials

---

## Design

Spiral bevel-gear drives – with or without intersecting axes – are now almost always used for front and rear axle drives. Very high axial loads arise which, with non-intersecting axes, may be several times the tangential load at the pinion. Due to the limited space and the elevated torque values, the pinion bearings are very heavily loaded. The pinion bearings should provide for even meshing of pinion and crown wheel under load; therefore, the pinion bearing arrangement should be as rigid as possible. The pinion is either an overhung or a straddled arrangement. The overhung arrangement is usually fitted with two tapered roller bearings *adjusted* against one another. Compact bearing arrangements (double-row tapered roller bearings with an unsplit cup or a cup with a flange) are common. The crown wheel is mounted in common with the differential. The meshing accuracy of the teeth should vary as little as possible and mounting should, therefore, be provided with sufficient rigidity. The rigidity requirements are easier to meet than with the pinion since more mounting space is available for this application and the axial loads are generally lower.

## Bearing adjustment

Rigid pinion and crown wheel guidance is achieved by *adjusting* the bearings against each other with a preload. With grey-cast iron housings, thermal expansion of the shaft increases the preload in nearly all cases after operating temperature is reached; the preload must, however, never be such as to exceed the elastic limit of the bearing material.

The opposite applies to aluminium housings, which are being used more and more because of their lightness. So, the preload has to be selected such as to achieve the required rigidity, but the additional bearing loading must not significantly reduce the *bearing life*. This is the case if the axial preload does not exceed about half the external axial force  $F_a$  applied.

## Lubrication

Differentials rely exclusively on *oil* lubrication. Bearings and gears are lubricated with the same *oil*. Since the lubricant is subjected to severe stressing in the spiral gearing, hypoid oils with *EP additives* are used. While the splash *oil* sufficiently lubricates the crown wheel shaft bearings, which have to accommodate lower loads, inlets and outlets must be provided for the *oil* for the pinion shaft particularly for the bearing on the flange side. Attention should be paid to the oil flow direction which is always from the small end to the large end of the tapered rollers. The oil ducts have to be arranged and dimensioned such as to ensure that *oil* circulates in every speed range.

The pinion shaft is normally sealed by means of radial shaft *seals*, in some cases in combination with a flinger sheet.

## Bearing dimensioning

*Fatigue life* analysis of the bearings mounted in differentials is based on maximum torque and corresponding speed as is the case with automotive gearboxes. The percentage times at the individual speeds are based on experience. This information is then used to determine the mean index of *dynamic stressing*. The rolling bearings mounted in cars should have an average  $f_{Lm}$  value of 1...1.3.

*Wear* of these bearings should be minimal since differential drives require a high guiding accuracy and as quiet running as possible. With today's bearing dimensioning the *service life* of differential bearings is either terminated by fatigue or *wear*.

A detailed calculation of the *attainable life* is usually not necessary as these bearings have proved their worth sufficiently in the automotive sector. Bearing dimensioning based on a comparison calculation with the *index of dynamic stressing*  $f_L$  is sufficient.

# 34 Final drive of a passenger car

## Operating data

Maximum engine torque 160 N m at 3,000 min<sup>-1</sup>.

## Bearing selection

### Pinion shaft

The pinion shaft is fitted with FAG inch-dimensioned tapered roller bearings mounted in *O* arrangement. Dimensions: 34.925 x 72.233 x 25.4 mm (dynamic load rating  $C = 65.5$  kN) and 30.163 x 68.263 x 22.225 mm ( $C = 53$  kN).

The pinion is accurately positioned relative to the crown wheel by means of shims inserted between housing shoulder and bearing cup. The cones are *circumferentially loaded*. But only the cone of the larger bearing can be *press-fitted*. The cone of the smaller bearing is slide-fitted because the bearings are *adjusted* through this ring.

### Crown wheel

Crown wheel and differential are mounted on the same shaft. Fitted are two FAG inch-dimensioned

tapered roller bearings of 38.1 x 68.288 x 20 mm;  $C = 39$  kN.

Both bearing and gear mesh *adjustment* are achieved by means of shims.

## Machining tolerances

Pinion shaft: m6 (larger-size bearing)  
h6 (smaller-size bearing)  
housing P7

Crown wheel: hollow shaft to r6  
housing to H6.

To allow the pinion to be *adjusted* to a certain torque and to avoid expensive fitting work (for instance machining of a solid spacer), a thin-walled preformed sleeve is provided between the bearing cones. The sleeve is somewhat longer than the maximum distance between the two bearing cones. Depending on the width tolerance values of the bearings there will be some elastic deformation of the sleeve (a few microns at most).

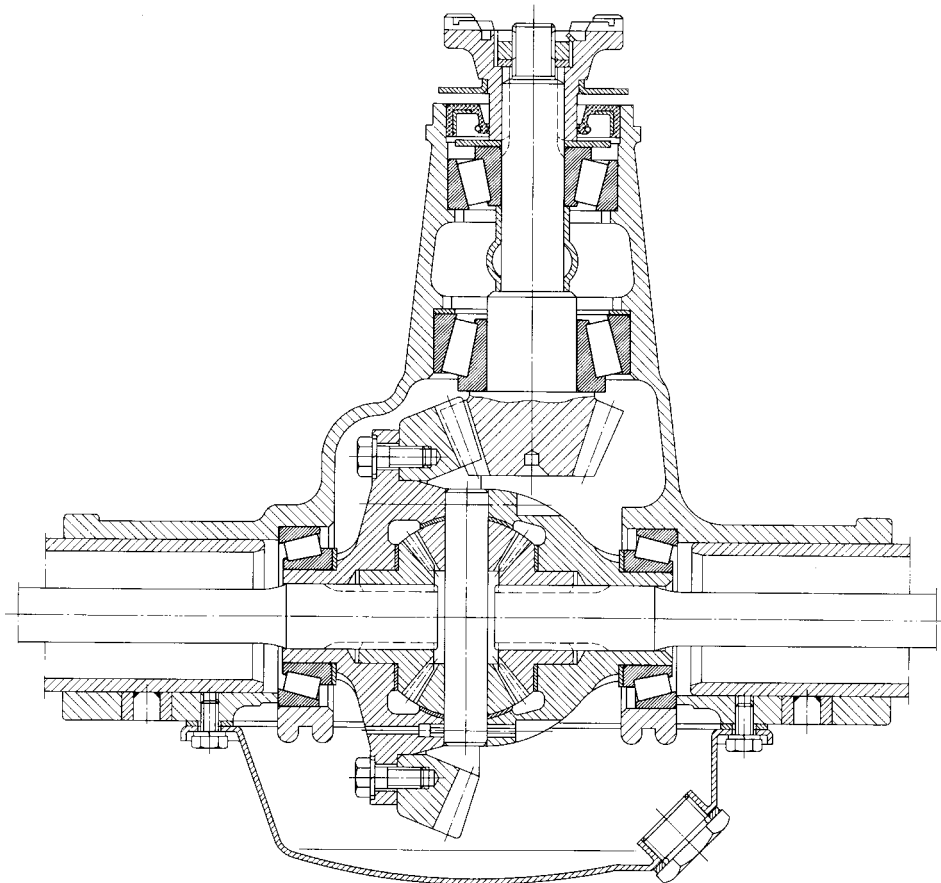

34: Final drive of a passenger car

---

# 35–39 Automotive wheels

---

Differences exist between driven and non-driven wheels for automobiles; the bearings can be either steerable or non-steerable. Basically, all wheels must be guided as accurately and clearance-free as possible for driving control reasons. This is in most cases achieved by using angular contact ball bearings or tapered roller bearings which are *adjusted* against each other.

## Front wheels

Where steered, non-driven front wheels are concerned, the axle or shaft journal are relieved of torque transmission and can, consequently, be given relatively small dimensions. The tendency towards compact wheel bearing units is encouraged by the wish for the smallest roll radius possible as well as the pressure to reduce weight and to simplify series mounting. Double-row angular contact ball bearings are almost always selected where the ratio of the mounting space for the wheel bearings axial width to the radial cross section height is less than 2.5. The following advantages can then be felt:

- little space is required in the axial direction, a large spread and, therefore, a high moment load carrying capacity due to a large *contact angle*,
- total weight of the bearings is low,
- suitable for integration in bearing units,
- flanges can be more easily integrated – particularly at the inner ring – than with tapered roller bearings.

## Rear wheels

With non-steered rear wheels, the radial mounting space is generally limited not only in the case of conventional drum brakes but also in vehicles with disc brakes since an extra drum brake is usually mounted at the rear wheels as a parking brake. The actuation mechanism is inside the drum near the axle and limits, as a result, the maximum outside diameter of the hub. In comparison, the axial mounting space is normally not as restricted so the wheel bearings do not have to be particularly short.

Today's standard bearing arrangement for such wheels, therefore, consists of two relatively small single radial tapered roller bearings which are mounted at a larger distance. The bearings have small *contact angles* so that the highest *load rating* possible is reached in a small mounting space. The necessary *spread* to accommodate tilting forces is achieved with the large bearing distance.

With the wide range of standard tapered roller bearings, this simple bearing arrangement, which is inexpensive where solely the bearing costs are concerned, offers diverse variations for all vehicle types and sizes.

There are, however, also some disadvantages particularly with large series:

- Numerous single parts must be purchased, stored and mounted.
- The bearings have to be greased and *sealed* during mounting.
- The bearing system must be *adjusted* and the adjusting elements secured in the correct position.

Therefore, for rear wheels there is also a tendency to use double-row angular contact ball bearings which do not have to be *adjusted* when mounting and which can easily be integrated in bearing units.

## Machining tolerances

The outer rings or cups of non-driven wheel bearings (hub bearings) are subjected to *circumferential load* (interference *fit*) whereas the inner rings or cones accommodate *point load* (loose, sliding or wringing *fit*); this facilitates mounting and bearing adjustment.

The inner rings or cones of driven wheel bearings are *circumferentially loaded*, and the outer rings or cups are *point-loaded*; this has to be taken into account when selecting the machining tolerances.

Non-driven front or rear wheels with two angular contact ball bearings or two tapered roller bearings:  
inner bearing: shaft to k6 (h6)

hub to N6, N7 (P7 for light-metal hubs)

outer bearing: axle journal to g6...j6

hub to N6, N7 (P7 for light-metal hubs)

Driven front or rear wheels with double-row angular contact ball bearings (bearing unit):

shaft to j6...k6

hub to N6, N7 (P7 for light-metal hubs)

## Bearing dimensioning

For the *fatigue life* calculation of wheel bearings, the static wheel load, the dynamic tyre radius  $r_{\text{dyn}}$  and its coefficient of adhesion, as well as the speeds of the vehicle in the operating conditions to be expected, are taken into account. The loads on the individual bearings or – for double-row bearings on the individual *rolling element* rows – are determined with the forces and moments calculated. The calculation results can only be taken as reference values. Normally the ideal  $f_t$  values for passenger cars are approximately 1.5 and for commercial vehicles approximately 2.0.

---

---

## Lubrication, sealing

Wheel bearings are almost exclusively lubricated with *grease*. Bearings which have no integrated *seals* are normally sealed with spring-preloaded shaft *seals* with special dust lips. Sealed bearings such as the double-row angular contact ball bearings with for-life lubrication,

which are widespread in passenger cars, normally have a combination of dust shield and seal. Experience has shown that these *seals* are satisfactory if the design provides an additional gap-type seal. Collecting grooves and baffles are also required to protect the bearings against dust and splash water.

---

# 35 Driven and steered front wheel of a front drive passenger car

---

## Operating data

Wheel load 4,600 N; tyre size 175/70 R14;  
 $r_{\text{dyn}} = 295$  mm; maximum speed 180 km/h.

The bearing is greased for *life* with FAG rolling bearing *grease*.

## Bearing selection

The bearing arrangement is made up of a *sealed* double-row FAG angular contact ball bearing.

The bearing arrangement of a driven and non-steered rear wheel of a rear drive passenger car may also be designed like this.

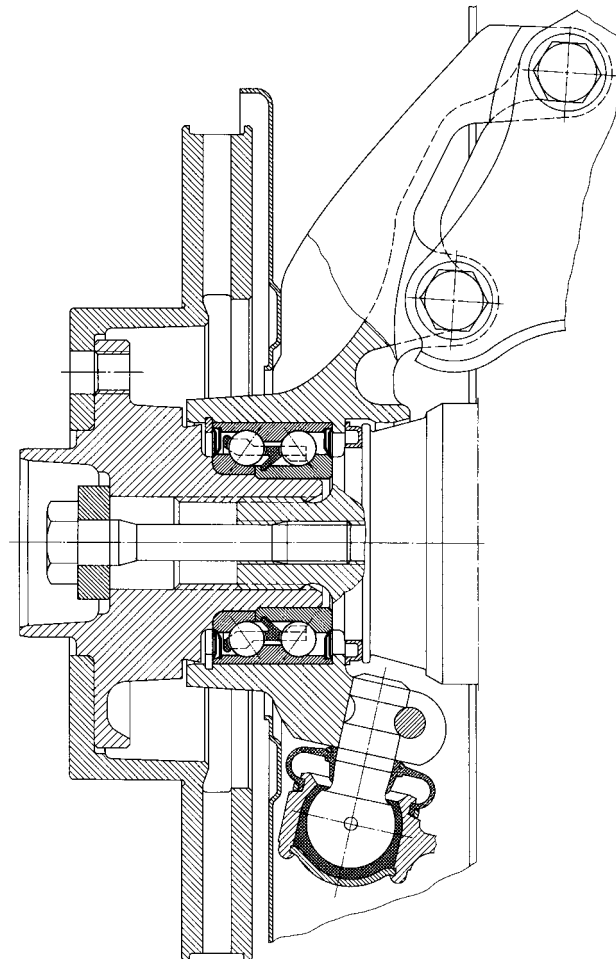

35: Passenger-car front wheel

# 36 Driven and non-steered rear wheel of a rear drive passenger car

## Operating data

Wheel load 4,800 N; tyre size 195/65 VR15;  
 $r_{\text{dyn}} = 315$  mm; maximum speed 220 km/h.

## Bearing selection

The wheel bearing arrangement consists of a double-row FAG angular contact ball bearing which is *greased for life*.

*Seals* and flinger rings provided on both sides protect the bearing from contamination.

## Machining tolerances

The inner rings and the outer ring of the bearing are tightly *fitted*.

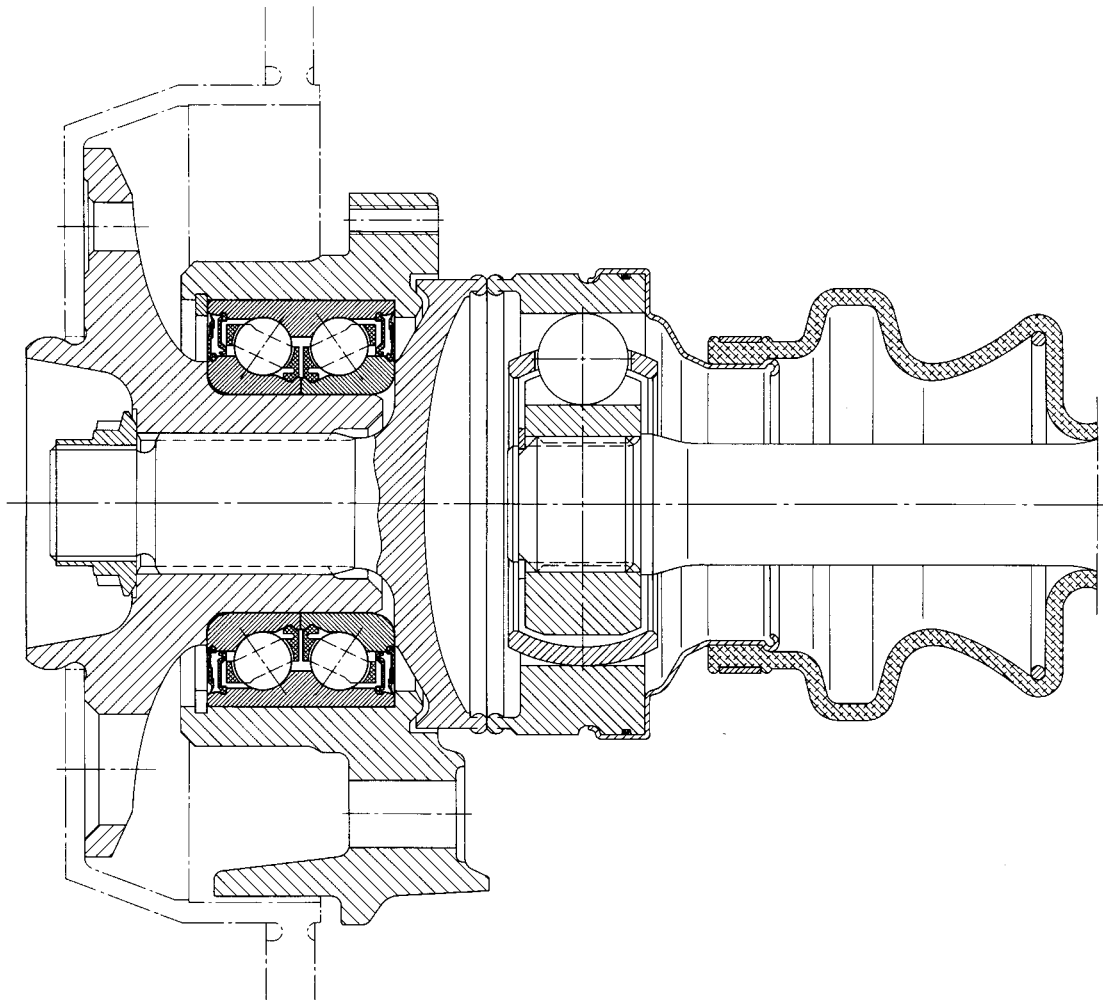

# 37 Driven and non-steered rear wheel of a rear drive truck

The rear wheel hubs of heavy trucks often feature a planetary gear. This type of drive provides a relatively high gear ratio in a limited space. As the high driving torque is generated directly at the wheel, small differential gears and light drive shafts are possible.

## Operating data

Wheel load 100 kN; tyre size 13.00-20;  
 $r_{\text{dyn}} = 569 \text{ mm}$ ; permissible maximum speed 80 km/h.

## Bearing selection

### Wheel bearings

Tapered roller bearings FAG 32019XA (T4CC095 according to DIN ISO 355) and FAG 33021 (T2DE105 according to DIN ISO 355). Since these bearings have a particularly low section height they require only a small radial mounting space thus allowing light-weight constructions. The relatively large bearing width and long rollers result in a high load carrying capacity.

The bearings are *adjusted* against each other in *O* arrangement (large spread).

### Planetary gears

The outer planet drive increases the driving torque in a minimum space. The planet gear bearing arrangement is of the full-complement type, i.e. it features two rows of needle rollers. Axial guidance is provided by thrust washers.

## Machining tolerances

Direct bearing arrangement

with needle rollers: shaft to h5; housing to G6

Tapered roller bearing: shaft to j6; housing to N7

## Lubrication

Common *oil* lubrication for planet drive and wheel bearings. An oiltight, welded housing protects gear and bearings against contamination.

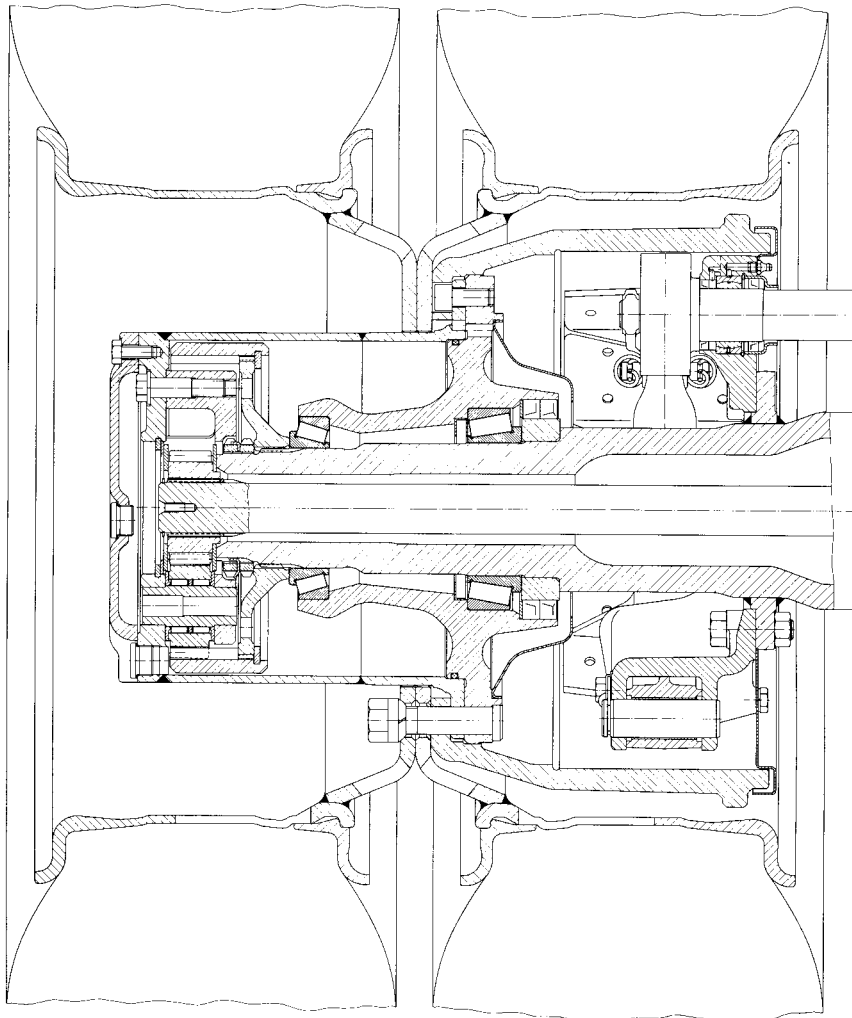

37: Rear wheel of a truck

# 38 Steering king pin of a truck

A variety of steering king pin mounting arrangements are possible. The bearing arrangement with two *adjusted* tapered roller bearings for accommodating the axial loads is generally used in driven truck front wheels. In other cases the axial loads are accommodated by thrust ball bearings or tapered roller thrust bearings. Since the radial mounting space for king pin bearing mounting arrangements is usually very limited the radial loads (steering and guiding forces) are accommodated by a plain bearing made of bronze and drawn cup needle roller bearings which provide for easy steering.

## Mounting with a tapered roller thrust bearing

The shock loads on the steering king pin are very high. Therefore, the *thrust bearing* must have a high load carrying capacity and be mounted with zero clearance or preload. As the king pin performs only slight slewing motions no *cage* is required so that the number of *rolling elements* and, consequently, the load carrying capacity can be increased.

The example features a full-complement tapered roller thrust bearing as the *thrust bearing*. It has a profiled shaft-washer raceway and a flat housing-washer raceway. The sealed bearing is held together by a pressed steel cap, which simplifies mounting.

The bearing is filled with special *grease*; it can be relubricated if necessary. Openings in the *sealing lip* and the elasticity of the sealing material ensure the escape of the spent *grease*.

The clearance between the knuckle and the cross member is compensated for by shims. In this way, the thrust bearing can have zero clearance at best, which means higher shock-type loads. Experience has shown that this can be taken into account by means of an impact factor of  $f_z = 5 \dots 6$ , in the case of adjusted tapered roller bearings with an impact factor of  $f_z = 3 \dots 5$ .

The shaft washer of tapered roller thrust bearings is located by a relatively loose *fit* on the steering kin pin (g6); the housing washer has no radial guidance.

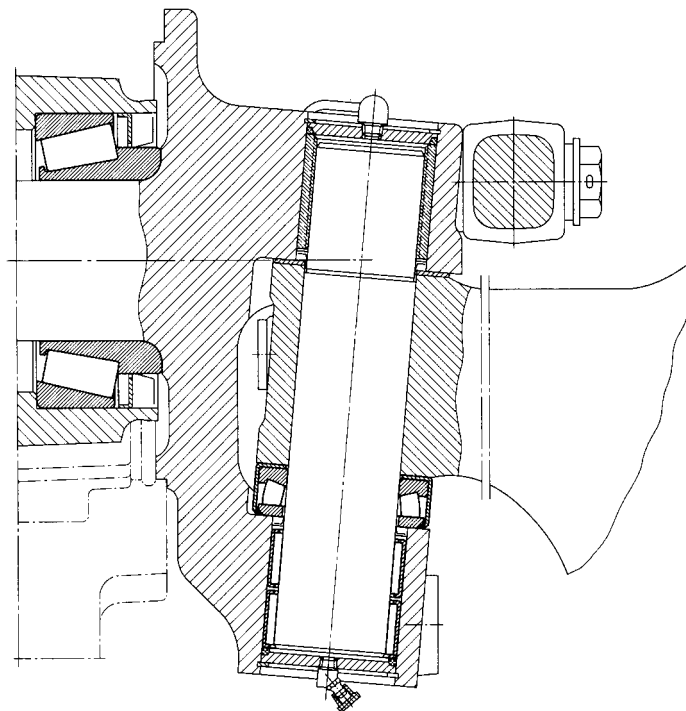

38: Steering king pin of a truck

# 39 Shock absorbing strut for the front axle of a car

Front axles are being equipped more and more frequently with McPherson shock absorbing struts. When driving, the coil spring and the damping unit of the McPherson strut cause movements relative to the body which are due to spring deflection and the degree of lock. For comfort reasons and for easy handling, these slewing motions are supported either by rolling bearings or rubber elements. Deep groove ball bearings best meet all requirements.

## Bearing selection

### Requirements

- Accommodation of weights and high shock loads
- Maintenance-free design

### Variants

- Damping unit and spring coil rotate together – single path solution (fig. a). The spring coil loads and the pulsating loads from the piston rod act on the strut bearing.  
Possible bearing designs: Deep groove ball bearings loaded axially (with *cage* or full-complement variants with a fracture-split outer ring) or thrust ball bearings.
- Movements of the shock absorber's piston rod and of coil spring are independent of each other – dual path solution (fig. b).  
Direct connection of shock absorber's piston rod to the body via a rubber element; coil spring supported by a special thrust ball bearing or angular contact ball bearing (spring seat bearing).  
Both variants meet all requirements concerning *sealing, for-life* lubrication and economic efficiency.

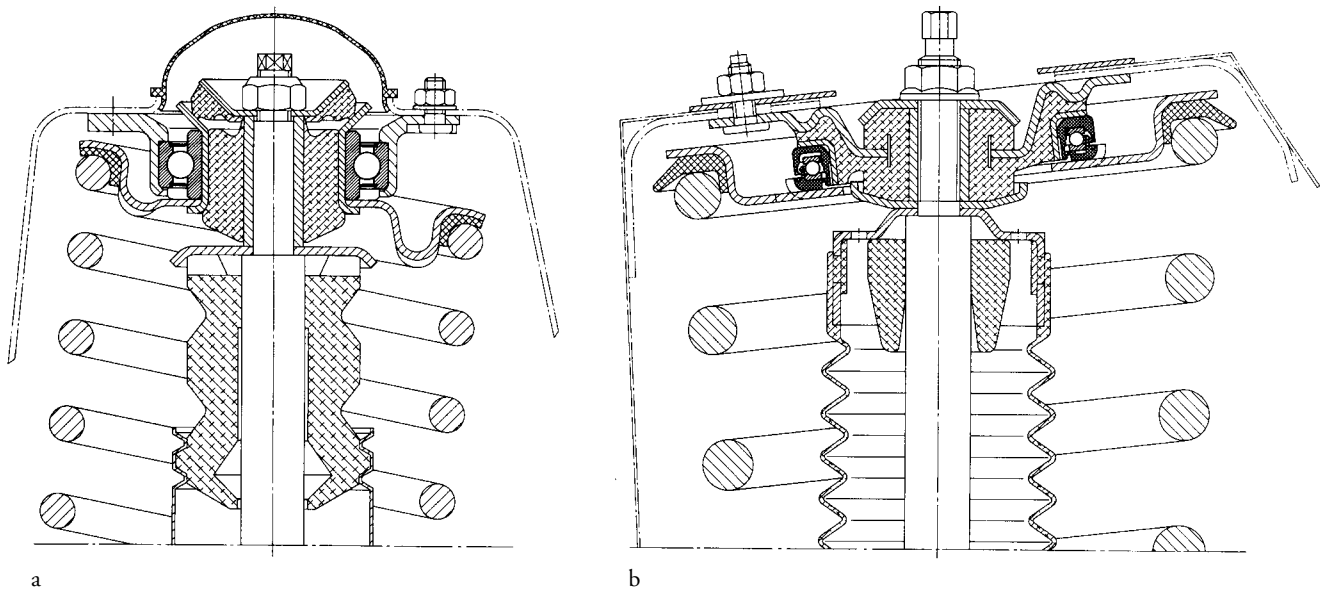

39: Shock absorbing strut for the front axle of a car; a: single path solution; b: dual path solution

# 40 Water pump for passenger car and truck engines

The water pump provides for circulation of the cooling water in the engine. Smaller and lighter pump designs are possible with ready-to-mount bearing units.

## Bearing selection

The water pump bearing unit consists of the shaft and a common outer ring with raceways for rolling-element-and-cage assemblies. The example features one ball-and-cage assembly and one roller-and-cage assembly each mounted in a *locating-floating bearing arrangement*. The roller-cage assembly is designed as the *floating bearing* at the side that is most heavily loaded by the belt pull. The ball-cage assembly is the *locating bearing*; in addition to the radial loads it also accommodates the thrust of the pump impeller.

## Machining tolerance, bearing clearance

The outer ring is mounted into the housing with an R7 interference *fit*. The bearing clearance of the unit is selected to allow for a small *operating clearance*.

## Lubrication, sealing

For-life lubrication with a special rolling bearing *grease*. Lip *seals* in the outer ring are provided on both sides against grease escape. A spring loaded axial face *seal* is fitted at the impeller end. Unavoidable water leakage is drained to the outside through the outlet bore.

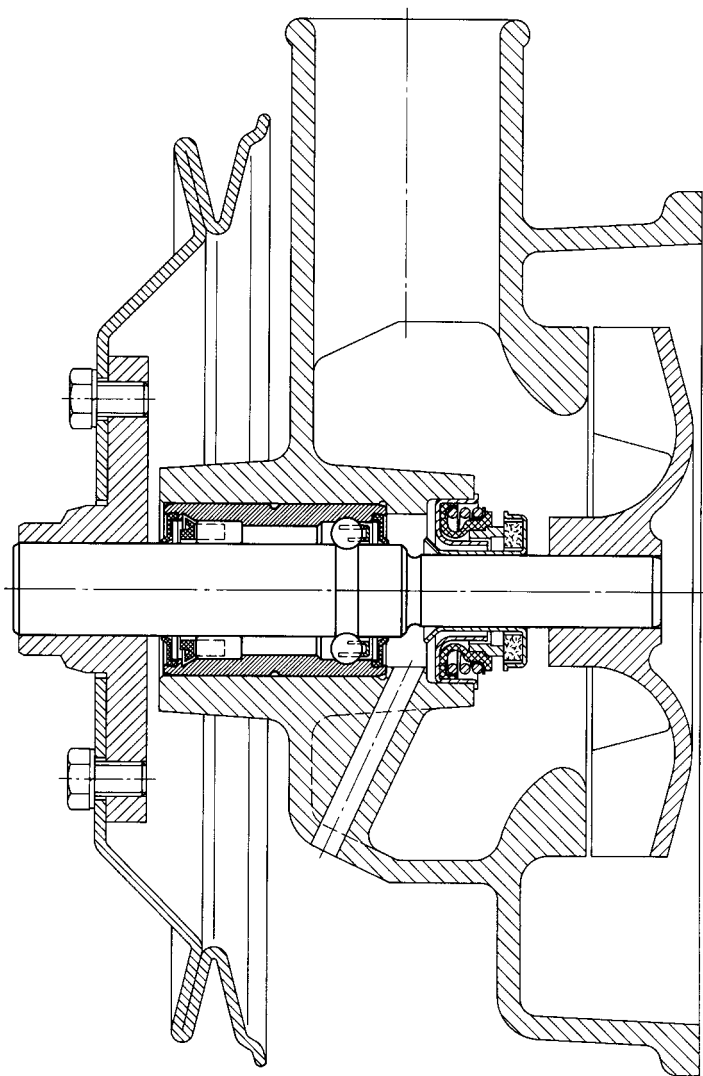

40: Water pump bearing unit for a truck engine

# 41 Belt tensioner for passenger car engines

The cam shafts of many four-cycle engines are driven with toothed belts from the crankshaft. The belt tension necessary for quiet running is provided by an FAG bearing unit. This tensioning pulley unit consists of a journal with integral raceways, a ball-cage assembly and an outer ring with the plastic injection-moulded tensioning pulley.

The screw bore for fastening the tensioning pulley to the engine housing is eccentrically located so that the belt tension can be applied by rotating the journal.

The bearing unit is *sealed* on both sides and packed with grease for *life*. Speed is approximately  $7,000 \text{ min}^{-1}$ .

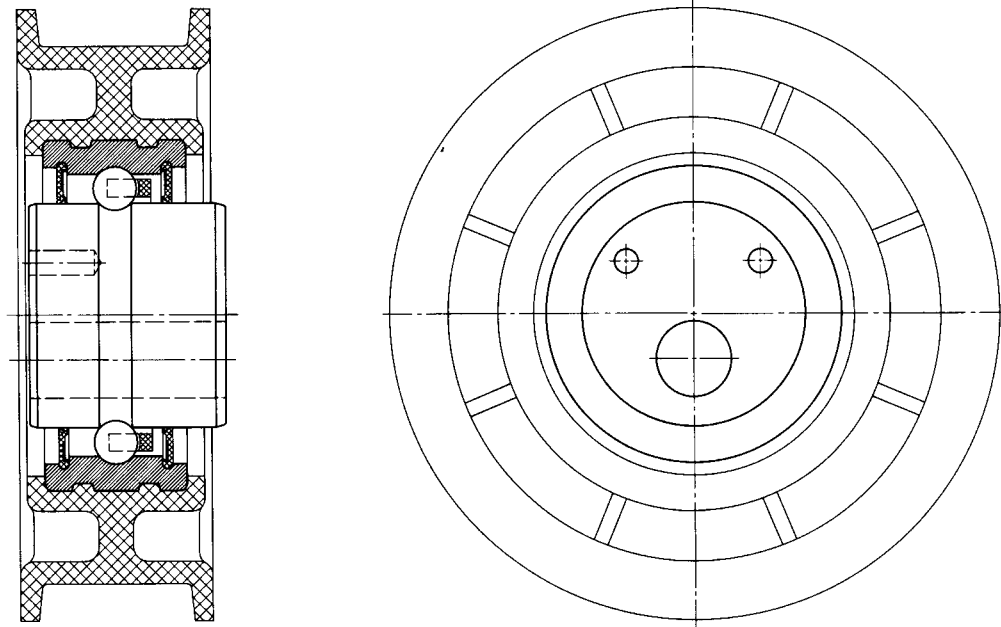

41: Belt tensioner for passenger car engines

# 42 Axle box roller bearings of an Intercity train carriage

The type of axle box roller bearings presented here is used for Intercity traffic in Europe. The bogie frame is supported on the bearing housing by a central coil spring, arranged above the bearings. The wheelsets are guided by plate-type guiding arms which are bolted on one side.

## Operating data

Deadweight of the carriage plus maximum payload: 64,000 kg; two bogies, each with two wheelsets, implies 4 wheelsets per car.  
Resulting axle weight per wheelset:  $A = 64,000/4 = 16,000$  kg; weight of wheelset  $G_R = 1,260$  kg; acceleration due to gravity  $g = 9.81$  m/s<sup>2</sup>; supplementary factor for dynamic loads occurring during operation  $f_z = 1.3$ ; thrust factor for cylindrical roller bearings  $f_a = 1$ ; number of bearings per wheelset  $i_R = 4$ .

Thus the *equivalent dynamic load* per bearing is:  
 $P = (A - G_R)/i_R \cdot g \cdot f_z \cdot f_a$

$P = (16,000 - 1,260)/4 \cdot 9.81 \cdot 1.3 \cdot 1 = 46,990$  N  
 $P = 46.99$  kN

Wheel diameter  $D_R = 890$  mm;  
maximum speed  $v_{\max} = 200$  km/h (possible speed 250 km/h).

## Bearing selection

Cylindrical roller bearings installed as axle box roller bearings offer important advantages:

Mounting is simple and they are easy to check and maintain in main inspections.

*Axial clearance* is irrelevant for *radial clearance*. Cylindrical roller bearings are pure *radial bearings*, but the lips allow the safe accommodation of all thrust loads (guiding forces) occurring in operation.

Of all the roller bearing types cylindrical roller bearings have the lowest friction. Their *speed suitability* is therefore greater than in the case of other roller bearings.

Cylindrical roller bearings do not, however, compensate for misalignment between axle and bogie frame.

Therefore misalignment must be corrected by angular freedom of the housing.

The same cylindrical roller bearings are used for passenger cars and freight cars. This simplifies stockkeeping.

Each axle box accommodates two cylindrical roller bearings, one FAG WJ130x240TVP and one FAG WJP130x240P.TVP.

The bearing dimensions (d x D x B) are 130 x 240 x 80 mm; the *dynamic load rating* C of one bearing is 540 kN.

The *nominal rating life* ( $L_{h10}$ ) is checked in kilometres when dimensioning the axle box bearings:

$L_{h10km} = (C/P)^{3.33} \cdot D \cdot \pi = (540/46.99)^{3.33} \cdot 890 \cdot \pi = 3,397 \cdot 2,497.6 \approx 9.5$  million kilometres.

Under these conditions the bearings are sufficiently dimensioned. 5 million kilometres (lower limit) applies today as a basis for dimensioning axle box bearings for passenger train carriages.

## Machining tolerances

Bearing inner rings carry *circumferential load*; therefore they are *press-fitted*: axle journal p6, housing H7.

## Bearing clearance

The tight *fit* expands the bearing inner rings which reduces *radial clearance*. The air stream cools the outer rings to a greater extent than the inner rings during travel which leads to a further reduction in *radial clearance*. Therefore the bearings have a *radial clearance* of 120 to 160 microns.

## Lubrication, sealing

The bearings are lubricated with a lithium soap base *grease*. Lamellar rings at the wheel side provide for effective non-rubbing *sealing*. A baffle plate at the cover end keeps the grease close to the bearing. Despite the small amount of grease ( $\approx 600$  g) high running efficiency (800,000 km and more) can be reached due to the *polyamide cages* without changing the lubricant.

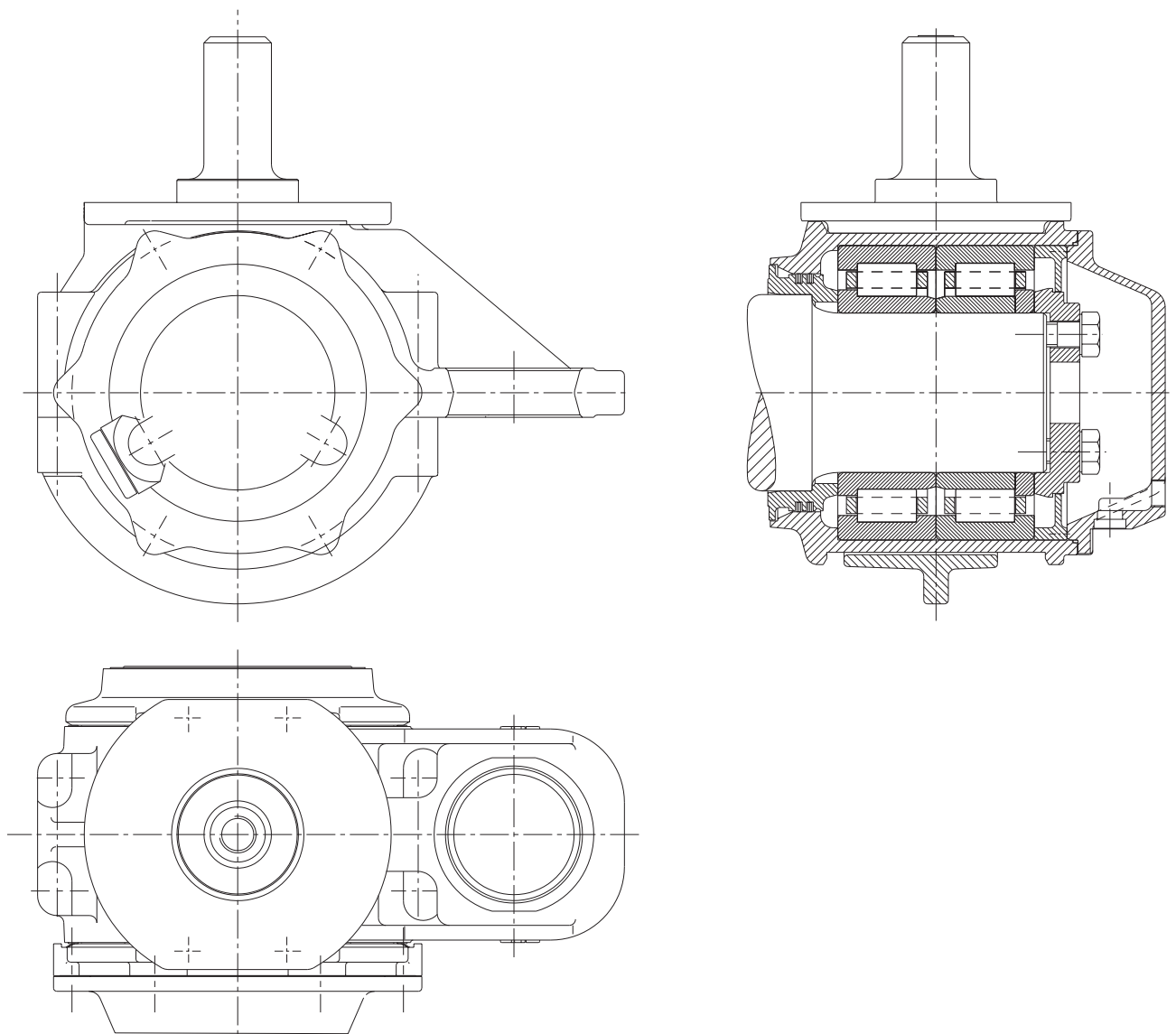

42: Axle box roller bearings of an Intercity train carriage

# 43–44 UIC axle box roller bearings for freight cars

The car body is supported by laminated springs on the wheelset. The laminated springs have the additional job of guiding the wheelset. To limit the swaying motion of the car body and to accommodate the thrust peaks, the housing features guiding surfaces in which the axle support of the frame is engaged. Cylindrical or spherical roller bearings are used as axle box roller bearings. The housing boundary dimensions of the UIC bearing are standardized. According to the latest UIC conditions 130 mm diameter journals are specified for cylindrical and spherical roller bearings. In some cases 120 mm journals are used for cylindrical roller bearings.

## Clearance

The tight *fit* expands the inner ring thus reducing *radial clearance*. A further clearance reduction results

from the air stream developed during travel which cools the outer ring more than the inner ring. Therefore, cylindrical roller bearings with a *radial clearance* of 130 to 180 microns and spherical roller bearings with increased *radial clearance C3* are chosen.

## Lubrication, sealing

The axle box roller bearings are lubricated with a lithium soap base *grease*. Felt seals combined with a labyrinth have proved most effective for cylindrical roller bearings.

UIC axle boxes with spherical roller bearings invariably use only labyrinth *seals*.

## Dimensioning, bearing selection

### Operating data

	43: UIC axle boxes with cylindrical roller bearings	44: UIC axle boxes with spherical roller bearings
Deadweight with max. payload $G_{\max}$	40,000 kg	40,000 kg
Top speed $v_{\max}$	100 km/h	100 km/h
Wheel diameter $D_R$	1 m	1 m
Number of wheelsets	2	2
Wheelset weight $G_R$	1,300 kg	1,300 kg
Weight on axle A	20,000 kg	20,000 kg
Number of bearings per wheelset $i_R$	4 cylindrical roller bearings	4 spherical roller bearings
Supplementary factor $f_z \cdot f_a$ ( $f_a = 1$ for cylindrical roller bearings where thrust loads are taken up by the lips; $f_a = 1.25$ for spherical roller bearings where thrust loads are taken up by the raceways.)	$1.3 \cdot 1 = 1.3$	$1.3 \cdot 1.25 = 1.625$
Equivalent load: $P = (A - G_R) \cdot g \cdot f_z \cdot f_a / i_R$ ( $g = 9.81 \text{ m/s}^2$ )	59.6 kN	74.5 kN
Average travelling speed ( $v_{Fm} = 0.75 \cdot v_{\max}$ )	75 km/h	75 km/h
Average wheelset speed $n = 5,310 \cdot v_{Fm} \text{ (km/h)} / D_R \text{ (mm)}$	$400 \text{ min}^{-1}$	$400 \text{ min}^{-1}$
Speed factor $f_n$	0.475	0.475
Index of dynamic stressing $f_L$	3.5	3.5
Required <i>dynamic load rating</i> of one bearing: $C = f_L / f_n \cdot P$	439 kN	549 kN
Bearings mounted:	Cylindrical roller bearings FAG WJ130x240TVP and FAG WJP130x240P.TVP	2 spherical roller bearings FAG 502472AA
Bore x outside diameter x width	130 x 240 x 80 mm	130 x 220 x 73 mm
<i>Dynamic load rating</i>	540 kN	585 kN
Machining tolerances of journals	p6	p6
Machining tolerances of housing bores	H7	H7
<i>Radial clearance</i>	130...180 $\mu\text{m}$	Clearance group C3

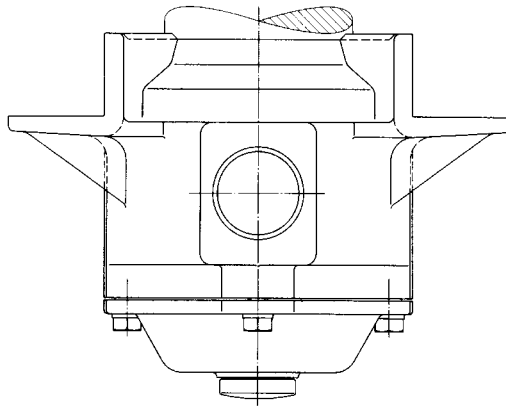
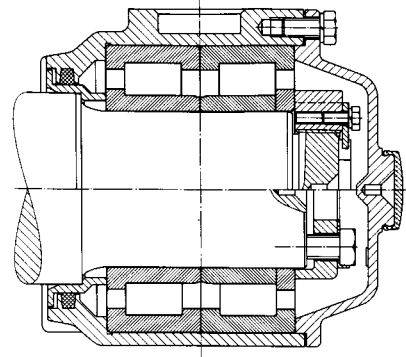
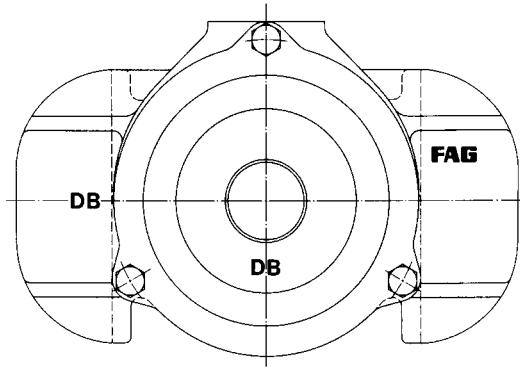

43: UIC axle boxes with cylindrical roller bearings

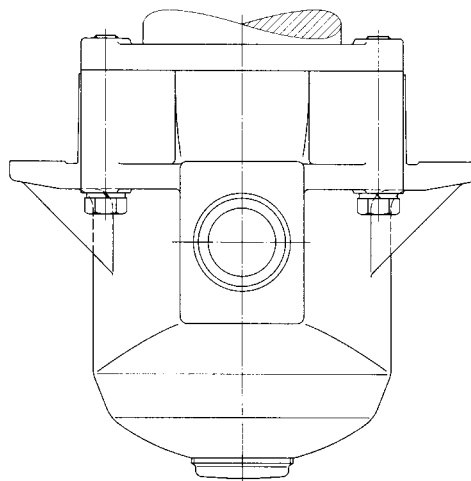
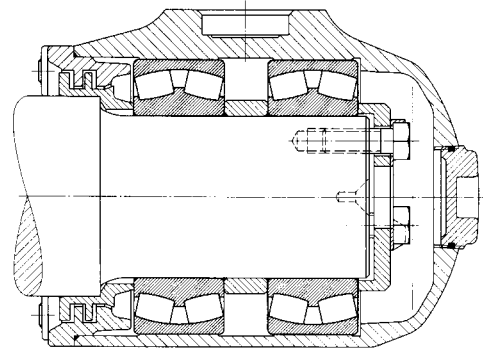
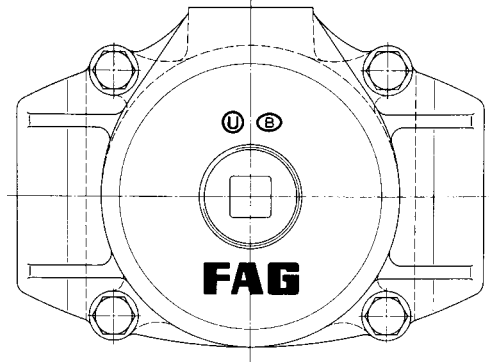

44: UIC axle boxes with spherical roller bearings

# 45 Axle box roller bearings of series 120's three-phase current locomotive

The frame is supported by coil springs and spring seats which are integrated in the bearing housing. The spring seats are arranged at different heights. The bearing is guided by an arm on each side which is linked diagonally to the housing. The arms are supported by elastic damping springs.

## Technical data

Vehicle weight: 84,000 kg

Number of wheelsets: 4

Wheelset weight: 2,250 kg

Axle load: 22,000 kg

Supplementary factor  $f_z = 1.5$

The locomotive reaches top travelling speeds up to 200 km/h.

## Bearing selection

Please refer to example number 42 to determine the *equivalent dynamic load P*.

Cylindrical roller bearings of the type NJ and NJP with the dimensions 180 x 320 x 75 mm are mounted.

*Dynamic load rating* of one bearing:  $C = 735 \text{ kN}$ . The outer and inner rings of both bearings are separated by spacer rings. The inner spacer ring is 2 mm wider than that of the outer rings.

The *axial clearance* which arises thereby, is necessary to compensate for bogie production tolerances. The bearing can always be mounted without preload.

## Machining tolerances

The bearing inner rings have *circumferential load* and are therefore given a tight *fit*: Journals to p6. The housing material, an aluminium cast alloy, has a greater coefficient of expansion than cast steel which is why the tolerance field J7 was selected and not the housing tolerance H7 usually taken for cast steel housings.

## Bearing clearance

Due to the tight *fit* the bearing inner rings expand; the *radial clearance* becomes smaller. The outer ring is cooled more than the inner ring by the wind resistance during travel which leads to a further reduction of clearance. For this reason bearings with increased *radial clearance C4* have been selected.

## Lubrication, sealing

A lithium soap base *grease* is used for lubrication. On the wheel side the bearing is sealed by a two-web labyrinth *seal*. A V ring seal protects from contaminants on the opposite side.

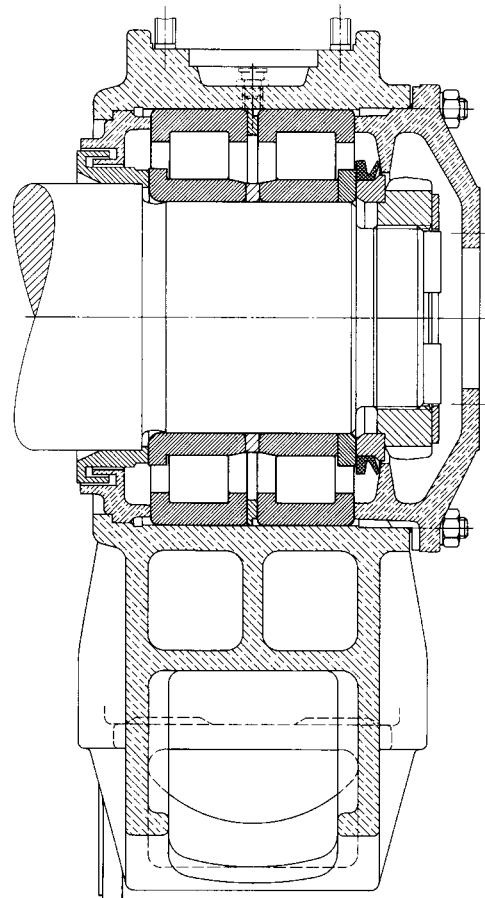
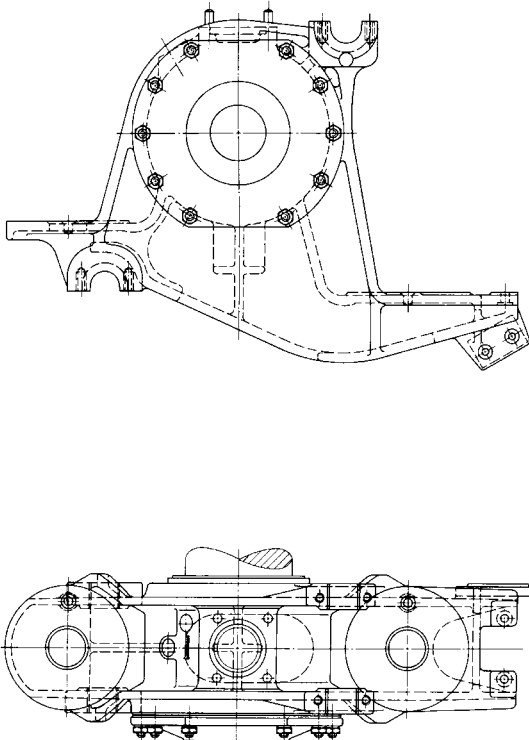

45: Axle box roller bearings of series 120's three-phase current locomotive

# 46 Axle box roller bearings for the ICE driving unit

The bogie frame is supported by 2 coil springs each on the bearing housings. The wheelset with the housings is connected to the bogie by an arm. A setting mechanism enables the mounting of the wheelsets in the bogies without preload. The bearing units are axially located by a cover.

## Operating data

Axle load: 19,900 kg  
Weight of unsprung weight: 2,090 kg  
Diameter of wheel 1,040 mm  
Maximum speed 250 to 280 km/h.

## Bearing selection

FAG tapered roller bearing units TAROL 150/250 are mounted in the wheelset housings of the series vehicles with the designation ET 401. The main component of these units is a double row tapered roller bearing with the dimensions: 150 x 250 x 160 mm.

## Machining tolerances

The cones carry *circumferential load* and therefore have a tight *fit*: journal to p6.

Housing to: H7 (for GGG material)  
J7 (for aluminium alloys).

## Bearing clearance

A slight *axial clearance* is required for ideal running behaviour of the bogies at top speeds. It is between 0.2 and 0.5 mm after mounting.

## Lubrication, sealing

The TAROL 150 is supplied as a complete unit which is sealed. The *sealing* system consists of two parallel outer diameter seated lamellar rings and one single-web labyrinth acting as a pre-seal. The labyrinth is shaped as a *seal cap* and pressed into the cup.

The *seal caps* are each provided with four discharge holes through which excess *grease* escapes. This is particularly important directly after relubrication. O rings protect the bearing unit from the penetration of water in the seating area of the cup.

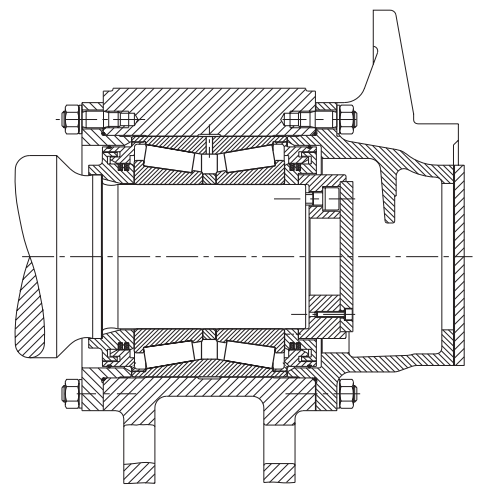
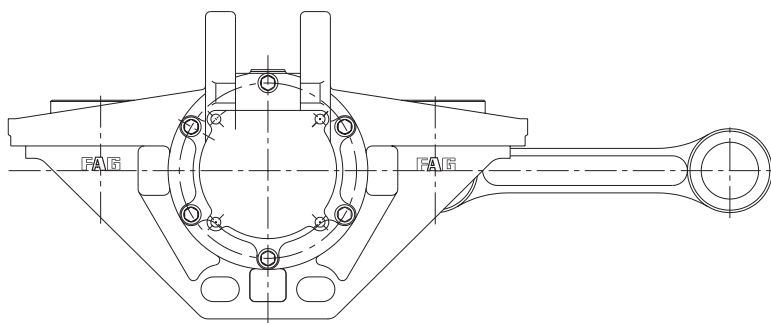

---

# 47 Axle box roller bearings of the Channel tunnel's freight engine, class 92

---

Class 92 is used for freight traffic in the Euro tunnel between Great Britain and the Continent. It is a two-system engine which means it can be operated on direct current (750 V) as well as on alternating current (25 kV). The engine with six axles (CoCo) draws loads weighing up to 1,600 t.

The vertical loads of the bogie are accommodated by two lateral coil springs on the housing of the axle box bearings. All lateral and longitudinal forces act via the guiding journals and sleeves which are attached to the bogie frame and the housing.

The middle axle of each triple axle bogie is designed as a floating axle box to insure trouble-free operation in narrow curves. The two outer axles are designed as standard axles as customary.

## Operating data

Vehicle weight 126,000 kg; two bogies each with three axles; wheel diameter 1,120 mm; top speed  $v_{\max} = 140$  km/h;

Power  $P = 5,000$  kW at 25 kV AC  
4,000 kW at 750 V DC

## Bearing selection

Tapered roller bearing units TAROL 150/250 with *pressed cages* (JP) are mounted to the outer standard axles of the vehicles. The bearings are clearance-adjusted, greased and *sealed* by the manufacturer. Fey lamellar rings provide for sealing on the side facing the wheel. A gap-type seal prevents rough dirt from penetrating the bearings.

The floating axle is accommodated in two cylindrical roller bearings whose dimensions are 150 x 250 x 80 mm. The extended inner ring allows axial displacement within the bearing of  $\pm 20$  mm at a maximum.

*Sealing* is achieved at the wheel end by means of long-webbed labyrinths.

## Machining tolerances

The inner rings carry *circumferential load* and have a tight *fit* to p6 on the journal.

The housing bores (*point load*) are machined according to H7.

## Bearing clearance

Prior to mounting, the TAROL units of the standard axle have an *axial clearance* of 0.665...0.740 mm and the cylindrical roller bearing units a *radial clearance* to C4 in order to compensate for heat expansion.

## Lubrication

Both bearing types are lubricated with a lithium soap base *grease*. While the lubricant in the TAROL bearings is only changed during the main inspections, the floating axle bearings must be relubricated in between. Due to the constant right to left displacement of the axle lubricant is removed from the bearing area and therefore has to be replaced regularly.

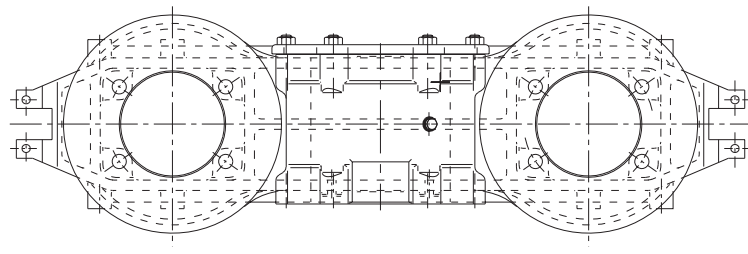
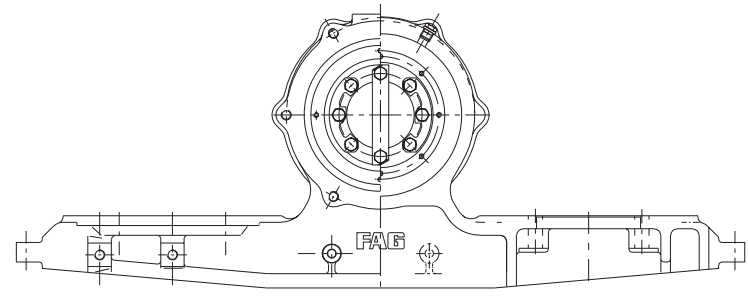
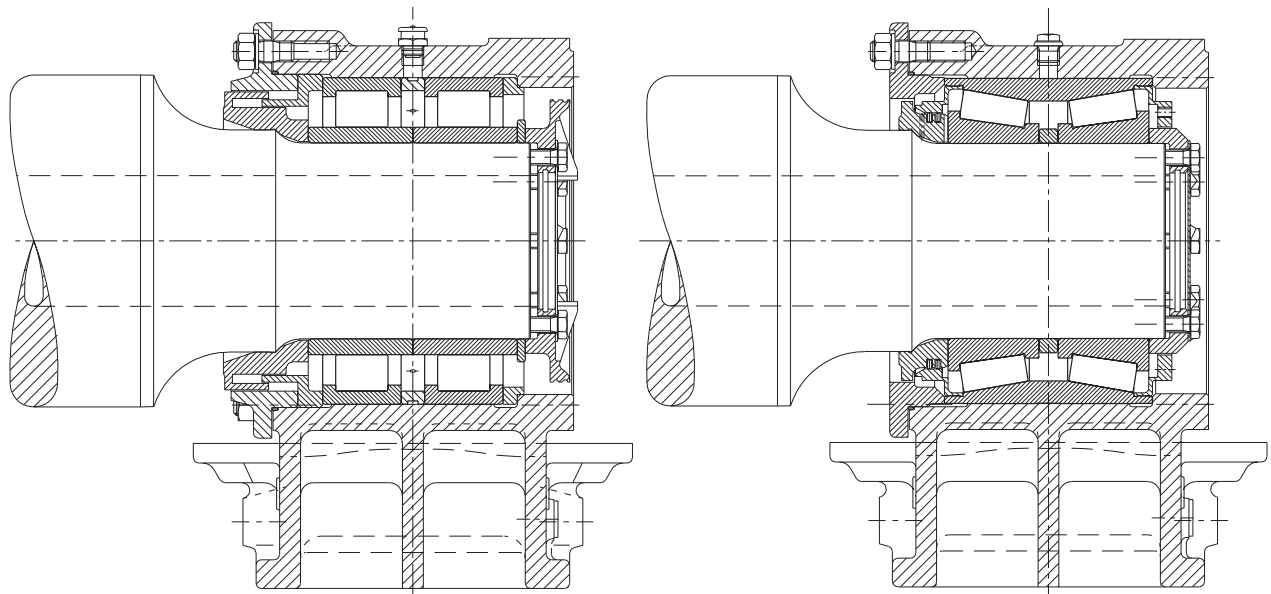

47: Axle box roller bearings of the Channel tunnel's freight engine, class 92

# 48 Axle box roller bearings for an underground train

A car has two bogies. Each axle box roller bearings is cushioned and guided by rubber-metal silent blocks. These are arranged between the axle box roller bearing and the frame opening. They are inclined to the vertical and have an angular cross-section.

## Operating data

Weight and maximum payload of one car: 34,000 kg.  
Number of wheelsets per bogie: 2.  
Wheelset weight  $G_R$ : 1,400 kg.  
Supplementary factor  $f_z$ : 1.3.  
Equivalent dynamic load  $P = 22.6$  kN.  
Wheel diameter  $D_R = 900$  mm.  
Top speed  $v_{\max} = 80$  km/h.

## Bearing selection

Two cylindrical roller bearings are mounted per axle box: One FAG NJ2318E.TVP2.C3.F2.H25 and one FAG NJP2318ED.TVP2.C3.F2 (dynamic load rating  $C = 430$  kN).

## Machining tolerances

The bearing inner rings carry *circumferential load* and are therefore given a tight *fit*: journal to m6, housing to H7.

## Bearing clearance

The inner rings increase due to the tight *fit*: the *radial clearance* decreases. The outer rings are cooled more than the inner rings due to the air stream during travel. This leads to a further reduction in clearance and therefore a *radial clearance C3* was selected.

## Lubrication, sealing

A lithium soap base *grease* is used for lubrication. A combination of a felt ring and a labyrinth was selected as a means of *sealing*. The labyrinth is provided with two axial webs since the axle boxes are subjected to extreme dirt.

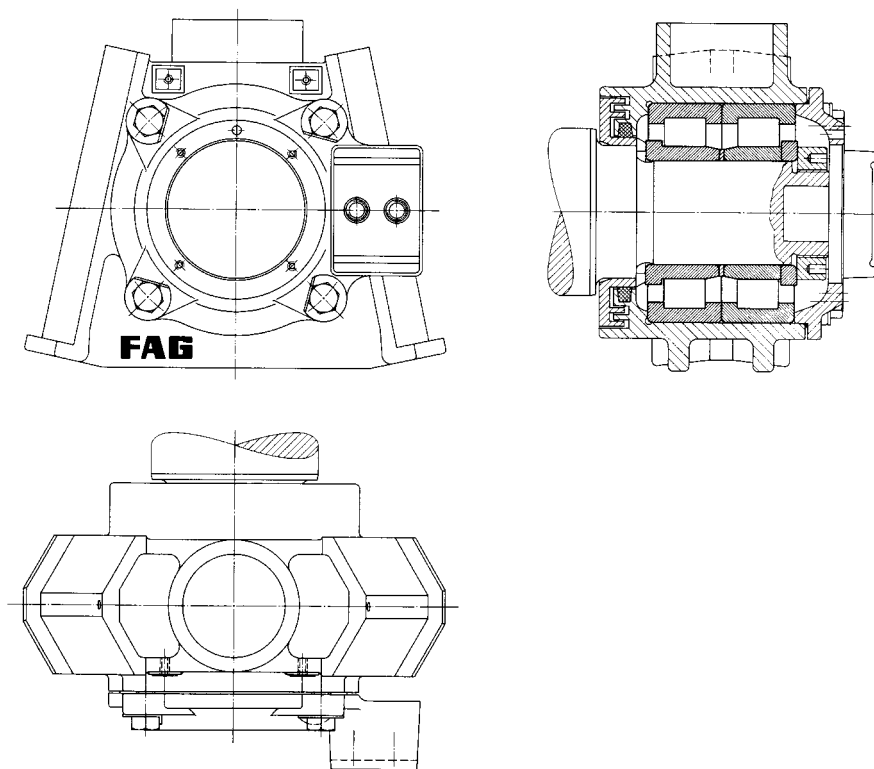

48: Axle box roller bearings for an underground train

# 49 Axle box roller bearings for a city train

The bogie frame is supported by Chevron springs on the axle boxes.

## Operating data

The *equivalent dynamic load*  $P_m = 37$  kN (calculated from the various load conditions).

Mean wheel diameter 640 mm.

Maximum speed  $v_{max} = 80$  km/h.

## Bearing selection

The main component of the FAG bearing units TAROL 90 used here is a double row tapered roller bearing whose main dimensions are (d x D x B overall widths cones/cup) 90 x 154 x 106/115 mm.

## Bearing clearance

Prior to mounting, the *axial clearance* of the bearing unit TAROL 90 is 530 – 630 microns.

## Machining tolerances

The bearing cones carry *circumferential load* and are therefore given a tight *fit*: journal n6.

## Lubrication, sealing

Lubrication is with a lithium soap base *grease*. The TAROL 90 is sealed at both ends with lamellar rings. The backing ring also has a collar which forms a gap-type seal with the lid on the wheel side.

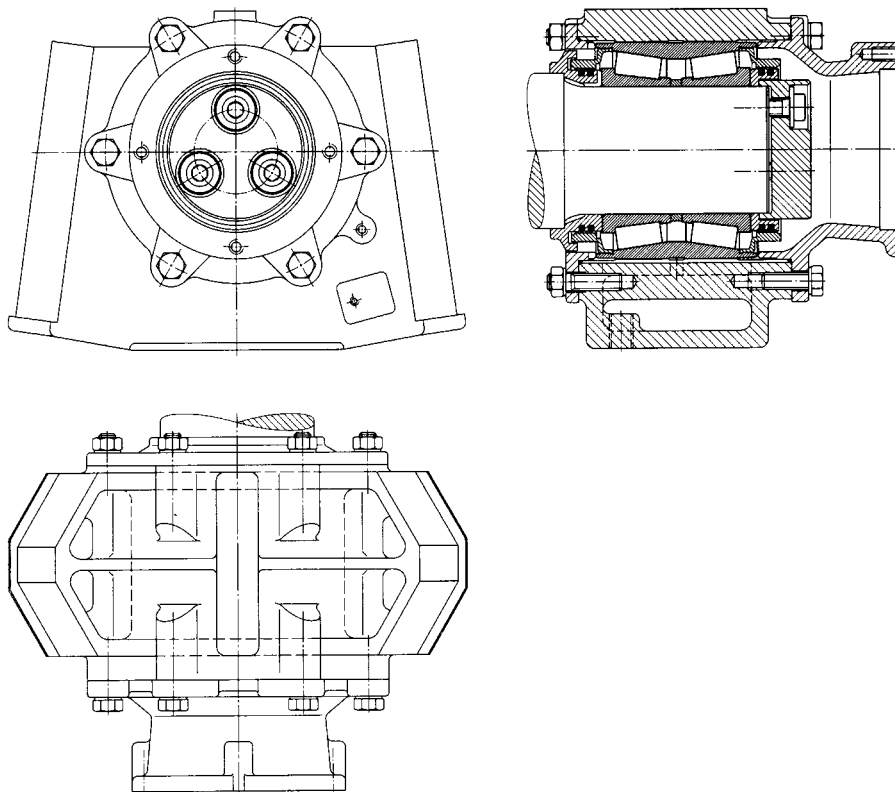

49: Axle box roller bearings for a city train

# 50 Axle box roller bearings according to AAR standard\*) and modified types

The FAG TAROL unit according to AAR standards is a compact bearing unit with a double row tapered roller bearing as the main component. *Seals* at both sides of the bearing, accessories and the *grease* filling make the FAG TAROL a ready-to-mount unit. Neither is the *adjustment* of the bearing clearance required. The so-called NFL design (no field lubrication) is considered standard today. These TAROL units are no longer relubricated during operation. The bearing grease is only renewed during a main inspection.

TAROL units do not have to be mounted into a housing. An adapter is attached between the TAROL unit and the bogie frame to transmit the loads and support the bearing cup on the loaded part of the circumference.

FAG supply NARROW and WIDE adapters according to the AAR standards as well as special adapters designed for the particular cases of application.

AAR has stipulated the admissible loads for the various sizes of TAROL units.

## Components of the FAG tapered roller bearing unit TAROL

- 1 Locking plate
- 2 Cap screw
- 3 End cap
- 4 Bearing cup
- 5 Bearing cone with roller set
- 6 Spacer
- 7 Seal wear ring
- 8 Seal
- 9 Backing ring

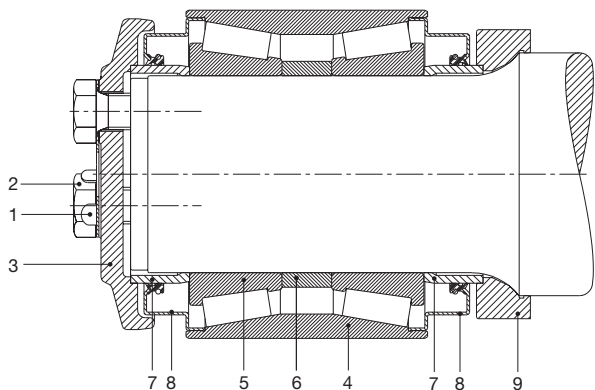

50: TAROL units with a double-row tapered roller bearing

FAG use two types of *seals*: the rubbing radial shaft seal (fig. a) corresponds to the design used by AAR. The non-rubbing lamellar *seal* ring (fig. b) was developed by FAG and tested and approved by AAR.

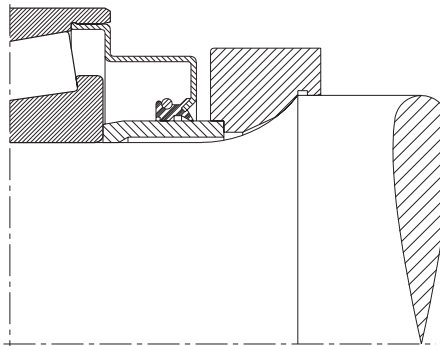

a: Rubbing radial shaft seal

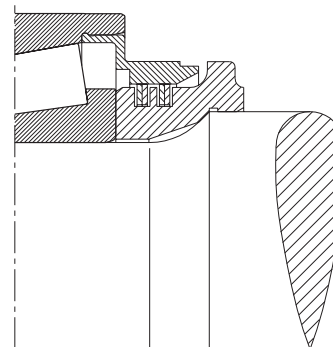

b: Non-rubbing lamellar seal

FAG also supply TAROL units in metric dimensions. They (fig. c) have narrower tapered roller bearings and smaller *sealing* and retaining components than the AAR design. The relevant journals are also shorter resulting in lower bending stresses with the same shaft diameter than in the case of the AAR arrangement. Higher wheel loads are therefore admissible.

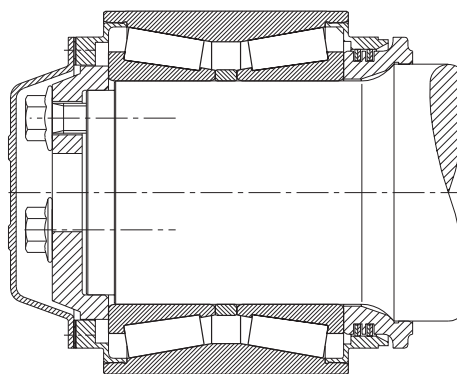

c: TAROL units in metric dimensions and with short journal (SK design)

\*) Association of American Railroads

# 51 Kiln trucks for sand lime brick works

## Operating conditions

In sand lime brick autoclaves the wheelset bearings of the kiln trucks are exposed for many hours to hot steam of approximately 200 °C at 16 to 22 bars. Due to corrosion hazard the bearing location should be protected against penetration of the steam which is strongly alkaline.

## Bearings

*Sealing* requires major attention when designing the bearing arrangement. The best solution is the use of pulverized *synthetic* FAG sealing agent and solid lubricant *Arcanol* DF. This lubricant is suitable for temperatures ranging between -200 °C and +300 °C and resists almost any chemical even at high temperatures. It is non-ageing and water repellent. The powder is packed into the bearing location penetrating into all cavities of the arrangement and forming a lubricating film between balls and raceways, balls and *cage* and also between outer ring and housing bore. The film in the housing bore ensures easy bearing displaceability, even after prolonged operation. This protects the bearing against detrimental axial preload.

In addition to lubrication *Arcanol* DF also acts as a sealing agent. It settles in the sealing gaps of the axle passage and protects the inside of the bearings against the ingress of alkaline condensate.

The bearings are designed for a truck with two wheelsets accommodating a total weight  $F_r$  of 43 kN. The bearing load for each bearing is relatively low at  $F_r/4$  allowing the use of inexpensive FAG 6208.R200.250.S1 deep groove ball bearings. Considering the high operating temperatures the bearings have a particularly large *radial clearance* (200...250 or 250...350 microns), are heat-treated according to S1 (200 °C) and are dimensionally stable.

The bearings of the kiln trucks are mounted on the shaft as far as its shoulder by means of a punching cap and fastened securely with a shaft end washer and screw. They have a loose *fit* in the housing bore of the FAG series housing SUB6208. Two bolts attach the housings to the frame of the trucks. Strips inserted between housing and frame compensate for any differences in height due to warping of the truck frame.

## Machining tolerances

Shaft: bearing seat j6.

Housing: the diameter of bearing seat is between 0.5 mm and 0.8 mm larger than the bearing O.D.

## Sealing

Heat-resistant aramide stuffing box packings seal the bearing area at the axle passage. The cover flange is also provided with a heat-resistant *seal*.

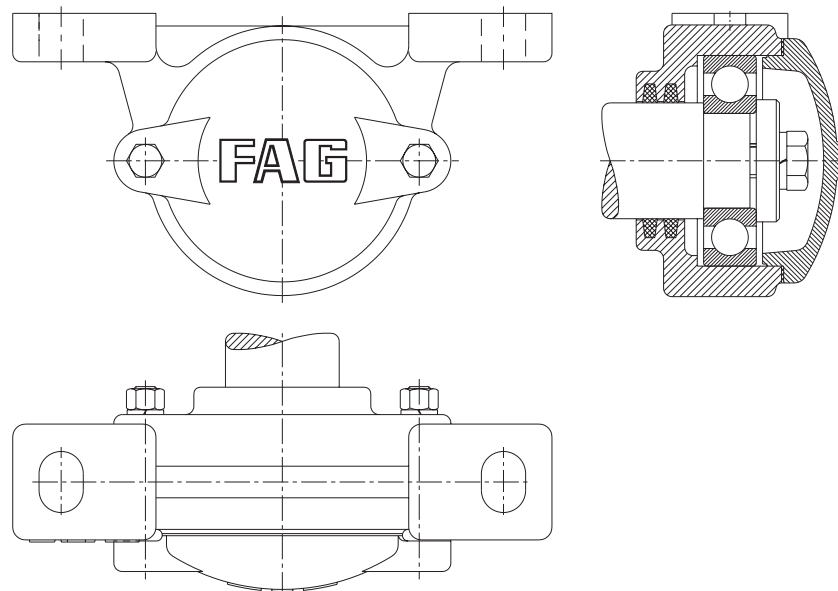

51: Kiln trucks for sand lime brick works

# 52 Universal quill drive for threephase current locomotives of series 120

All four wheelsets of series 120's threephase current locomotives are driven. The traction motor arranged transversely to the direction of travel is connected to the bogie at three points. The torque of the traction motor acts via pinion and bullgear on a universal quill drive which is linked to the bullgear and driving wheel by the articulated lever coupling. The driving wheel transmits the tractive force to the rails.

## Operating data

Top speed: 200 km/h; number of motors: 4; nominal power per motor: 1,400 kW; motor speed: max. 4,300 min<sup>-1</sup>.

## Bearing selection

The bullgear is supported on the universal quill drive in two tapered roller bearings FAG 534052 (dimensions: 381.03 x 479.475 x 49.213 mm) which are

mounted in *O arrangement*. Even with a small bearing distance there is a relatively large *spread* and as a result tilting rigidity is high.

The quill drive housing is stationary. The cones, which carry *point load*, have a loose *fit*. The cups carry *circumferential load* and have therefore a tight *fit* in the rotating bullgear.

The *axial clearance* of the bearing pair depends on the machining tolerances of the bearing seats and the operating conditions. With inner and outer spacer sleeves bearing *adjustment* is not necessary when mounting.

## Lubrication

During mounting the bearings and the space between the webs of the outer spacer sleeves are completely filled with a lithium soap base *grease* of the *NLGI class 2*. They are relubricated after every 150,000 km. The *grease* is fed through the holes of the sleeve's web.

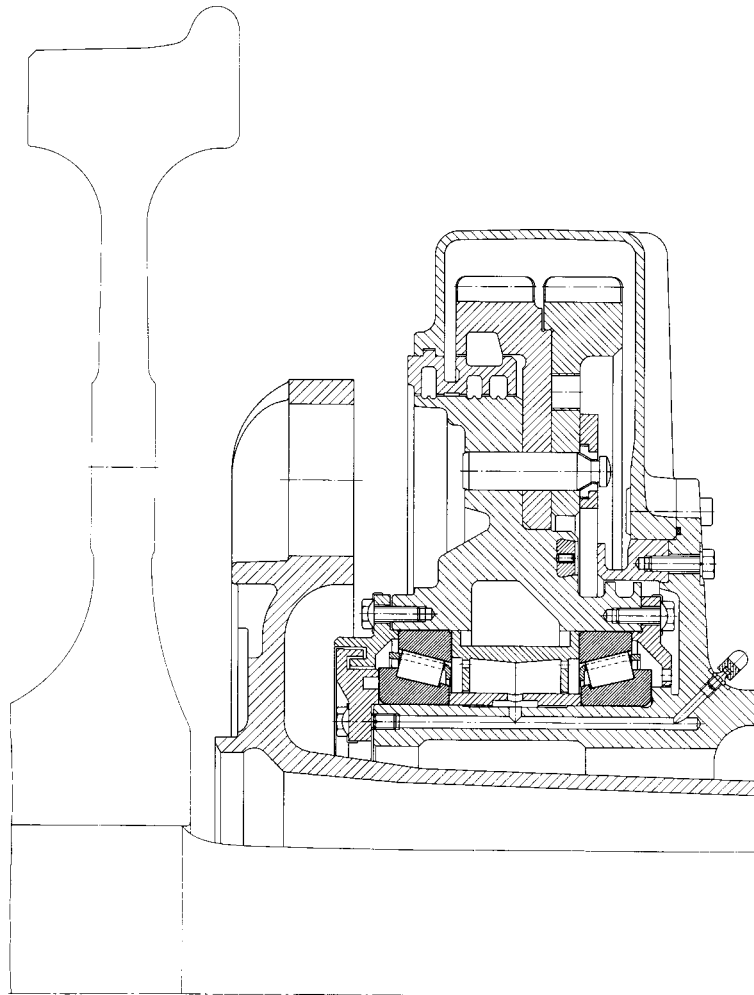

52: Bullgear bearing arrangement for a universal quill drive

# 53 Suspension bearing arrangement for electric goods train locomotive

The torque of the traction motor is transmitted to the wheelset axle via pinion and bullgear. The traction motor arranged transversely to the direction of travel is supported directly on the wheelset axle in two bearing locations. The reaction torque is taken up by another support point at the bogie frame.

## Operating data

Six driven wheelsets, power per traction motor: 500 kW. Max. speed: 100 km/h.

## Bearing selection, dimensioning

For a suspension bearing to have a long *service life* (*nominal life* over 2 million kilometres) roller bearings with a high load carrying capacity are selected. A medium drive torque and a medium speed are taken as a basis for dimensioning. The *index of dynamic stressing*  $f_L$  should be 3.5 at least. Usually it is well above it.

Two FAG tapered roller bearings are mounted their dimensions being 230.188 x 317.5 x 47.625 mm and 231.775 x 336.55 x 65.088 mm. They are abundantly dimensioned because of the large shaft diameter. High loads due to vibrations and shocks are accommodated

by special tapered roller bearings with reinforced *pressed cage* (reduced number of rollers).

Both tapered roller bearings are mounted in *O arrangement* with little *axial clearance* (0.2...0.3 mm). When the shaft has a maximum load the cups and cones are tilted by up to 3° against each other. The profile of the tapered rollers or raceways are modified (slightly crowned) in order to avoid edge stressing.

## Machining tolerances

The cups have *circumferential load* and an interference *fit* on the shaft. The cup or the angle sleeve in the housing is given a tight *fit* (perhaps a drive seat).

## Lubrication, sealing

The suspension bearings are lubricated with a lithium soap base *grease* of *penetration* class 3 with anti-corrosion *additives*. Baffle plates hold the grease at the bearing (grease storage).

The *relubrication interval* is about 200,000 to 300,000 km depending on the type of operation. Labyrinth gap-type *seals* protect the bearing from contaminants.

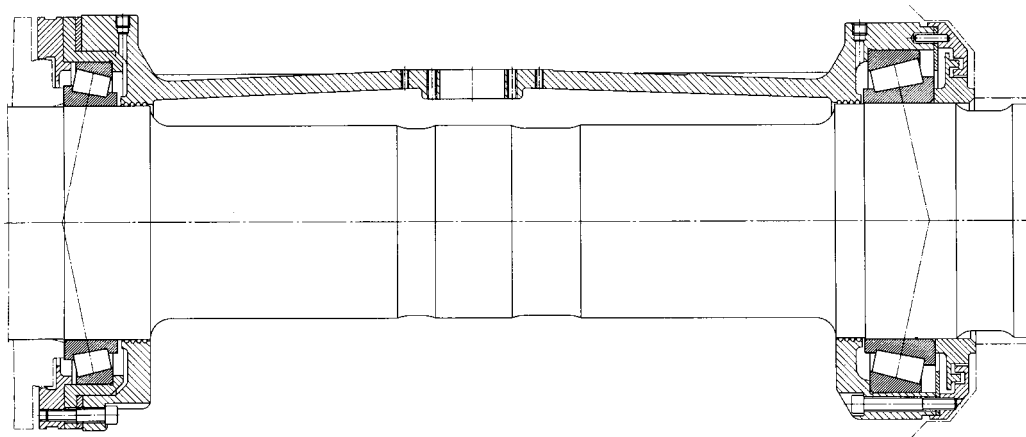

53: Suspension bearing arrangement for electric goods train locomotive

---

# 54 Spur gear transmission for the underground or subway

---

The drive of modern suburban vehicles should provide for a high degree of travel comfort, low noise, and be economical at the same time. These requirements are fulfilled by a new compact drive package which is completely supported on springs in the bogie.

## Operating data

Two step parallel shaft drive, helical/double helical gearing. Drive speed (input shaft)  $n_{\max} = 5,860 \text{ min}^{-1}$ , step-up  $i = 11.025$ .

The drive motor is flanged on to the transmission. A universal joint coupling transmits the torque directly to the wheelset from the transmission. The gearbox case, which is split at axis height, is made of high-strength cast aluminium. This is 25 % lighter than spheroidal graphite cast iron.

## Bearing selection

### Input shaft

The rotor of the drive motor is firmly attached to the input shaft of the transmission. An elastic coupling which can be subject to bending, avoids constraining forces in the shaft line which is supported in three positions by a *locating-floating bearing arrangement*. The *floating bearing* in the motor is a cylindrical roller bearing FAG NU212E (not illustrated). A second *floating bearing*, a cylindrical roller bearing FAG NJ215E, is at the motor end of the input shaft. The *locating bearing* arrangement of the input shaft is an angular contact ball bearing pair FAG 7215B.UA70 in *X arrangement*. Both angular contact ball bearings are fitted in an angle sleeve made of steel. Therefore different heat expansion coefficients of steel and light metal cannot have a direct effect on the bearings.

The bearings accommodate high speeds with a close axial guidance at the same time. This means tight *fits* for the bearing rings on the shaft and in the bore of the

angle sleeve. The demand for a sufficient axial *operating clearance* in addition to the tight *fit* is met with angular contact ball bearings in *universal design*. The *axial clearance* of the bearing pair prior to mounting is 70 microns.

### Intermediate shaft

A spherical roller bearing FAG 22218E is mounted as the *locating bearing* of the intermediate shaft. Its outer ring is in a steel angle sleeve. The spherical roller bearing accommodates chiefly axial forces from the gearing. The *floating bearing*, a cylindrical roller bearing FAG NJ2216E.C3, is directly in the light-metal housing with the outer ring. The very tight *fit* in the housing necessitates a bearing with increased *radial clearance* (C3).

### Output shaft

The output shaft whose large spur gear has a double helical gearing, is axially guided by the spherical roller bearing of the intermediate shaft. The *floating bearing arrangement* with two cylindrical roller bearings FAG NUZ1848 is therefore sufficient for the output shaft. The NUZ design with an extended inner ring raceway allows a large axial displacement of the hollow shaft.

## Machining tolerances

Angular contact ball bearing pair	Shaft k5; pair housing K6
Spherical roller bearing	Shaft m5; housing K6
Cylindrical roller bearing/intermediate shaft	Shaft m5; housing N6
Cylindrical roller bearing/output shaft	Shaft n5; housing N6...P6

## Lubrication

All the bearings of the transmission are lubricated by the *oil* circuit of the gearings.

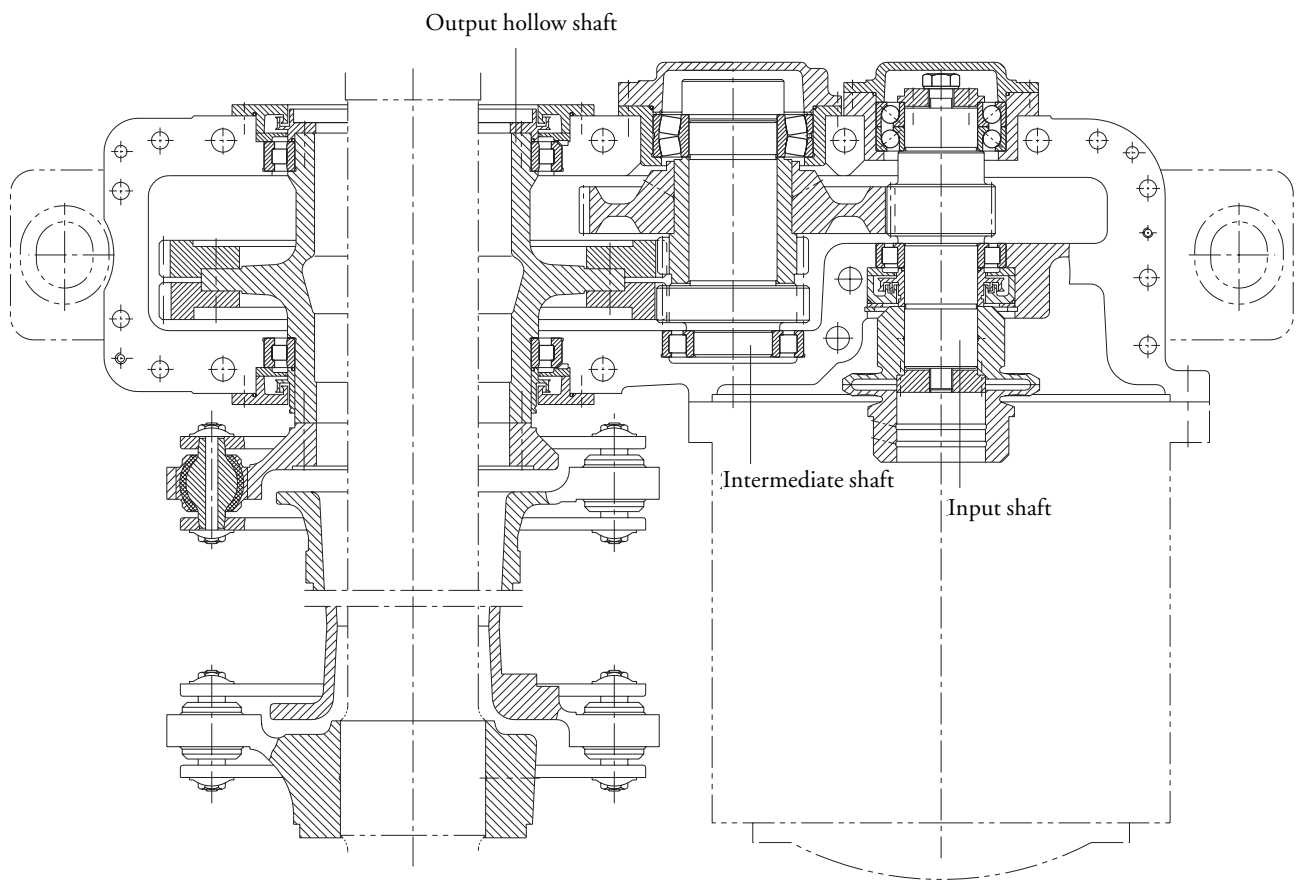

54: Spur gear transmission for the underground or subway

# 55 Bevel gear transmission for city trains

With a so-called two-axled longitudinal drive in underground and metropolitan vehicles the traction motor (usually direct current motor) is arranged in the bogie in the direction of travel. A bevel gear transmission is flanged onto both sides of the motor's face. The drive unit firmly attached to the bogie frame is elastically supported by the wheel sets. The drive power is transmitted from the pinion shaft to the hollow ring gear shaft and then via rubber couplings to the driving wheel shaft. This drive design leads to good running behaviour and moderate stressing for the traction motor, transmission and track superstructure.

## Dimensioning, bearing selection

Mean torques and speeds (hourly torque, hourly speed) are calculated from the tractive force – surface speed diagram and the time shares for the various running conditions. By means of the gearing data the tooth loads of the hypoid bevel gear step are calculated and, depending on the lever arms, are distributed to the bearing locations.

A *life* of 20,000 to 30,000 hours is assumed for bearing dimensioning. Assuming an average travel speed this corresponds to 1.2 – 1.3 million kilometers. To check the static safety of the bearings the maximum torque (slippage torque) is taken as a basis.

### Pinion shaft

A single-row cylindrical roller bearing FAG NJ2224E.M1A.C3 (120 x 215 x 58 mm) is mounted as a *floating bearing* at the pinion end. It accommodates the high radial loads. The *machined cage* of the bearing is guided at the outer ring. The bearing has the increased *radial clearance* C3 since the bearing rings have a tight *fit* on the shaft and in the housing. Two tapered roller bearings FAG 31316 (80 x 170 x 42.5 mm) are used as *locating bearings*. They are mounted in pairs in *O arrangement*. The bearing at the motor end accommodates the radial loads as well as the axial loads from the gearing; the other tapered roller bearing only accommodates the axial loads arising during a change in direction of rotation. A minimum bearing load is a requirement in order to avoid harmful sliding motion (slippage) and premature *wear*. The cups of the tapered roller bearings are therefore preloaded with springs.

### Ring gear shaft

There is a tapered roller bearing with the dimensions 210 x 300 x 54.5 mm at each side of the ring gear. Both bearings are *adjusted* in *X arrangement*.

## Machining tolerances

Cylindrical roller bearing:	Shaft m6, housing M6
Tapered roller bearing/ motor end:	Shaft m6, sleeve M6
Tapered roller bearing with mantle ring:	Shaft m6, ring R6 (S7)
Tapered roller bearing of ring gear shaft:	Shaft n6 – p6 housing K6 – M6

The *axial clearance* of the tapered roller bearing pair depends on gearing and the operating conditions.

## Lubrication

*Oil sump* lubrication provides the transmission bearings with lubricant. The flinger oil is conveyed via the ring gear from the oil sump and fed directly to the transmission bearings via oil collecting bowls and supply ducts. The special driving conditions for city trains demand highly doped *oils* which are resistant to heat and corrosion.

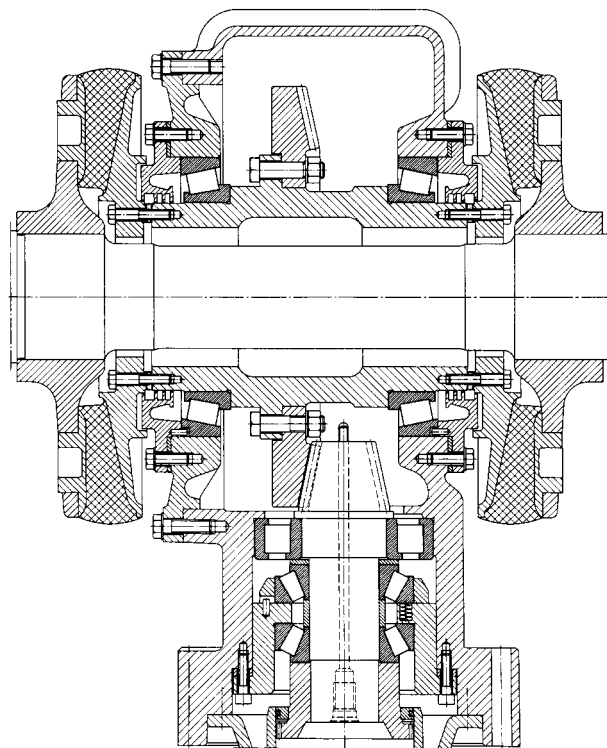

55: Bevel gear transmission for city trains

---

# 56–60 Rudder shafts

---

The rudders of ships make slow intermittent slewing motions. The maximum slewing angle is about  $35^\circ$  to both sides. The rudder shaft bearings accommodate the radial and axial loads arising from the rudder and the steering engine. The bearings are also subjected to the vibrations created by the propeller jet. There are numerous types of rudders the most common of which are illustrated in figs. a to c.

Rolling bearings are only used for the bearing positions of the rudders inside ships. They are not suitable for the bearing positions located outside the ship due to mounting difficulties and problems with *sealing* and lubricating. For such locations, plain bearings made of stainless steel, bronze, plastic etc. are used and water or a mixture of *grease* and water is used for lubrication.

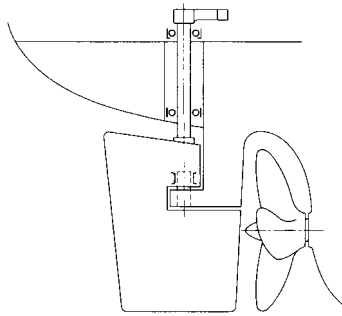

a) Semi-spade rudder

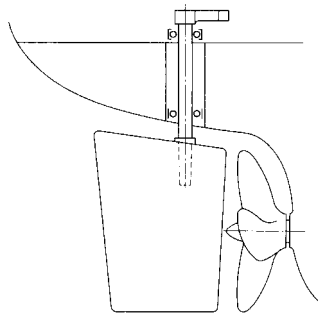

b) Spade-type rudder

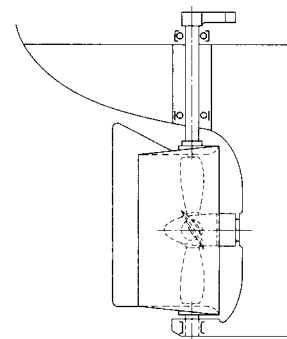

c) Steering nozzle

# 56–57 Spherical roller bearings as rudder shaft bearings

## Operating data

Axial load 115 kN (weight of rudder and shaft), radial load 350 kN (driving force of steering engine and rudder).

## Bearing selection, dimensioning

Due to the heavy loads and unavoidable misalignment spherical roller bearings are used. They have a high load carrying capacity and are *self-aligning*. The rudder shaft diameter depends on size and speed of the ship as well as on the type and size of the rudder used. The bearing bore and the size of the bearing are determined by the shaft diameter specified. A spherical roller bearing FAG 23052K.MB.R40.90 or FAG 23052K.MB.C2 (*radial clearance* 150...220 microns) is mounted. During mounting the bearing inner ring is pressed onto the tapered shaft seat so that the bearing operates under a light preload. Vibrations can thus be adequately accommodated. The hydraulic method facilitates dismounting particularly in the case of bearings with C2 bearing clearance. For this purpose the shaft must have oil ducts and the tapered seat a circular groove.

The housings of rudder shaft bearings FAG RS3052KS.1..... or FAG RS3052KW.1..... are made of welded shipbuilding steel plates.

The static safety of a rudder shaft bearing is checked because of the few slewing motions. An *index of static stressing*  $f_s$  between 4 and 5 is suitable for spherical roller bearings.

## Machining tolerances

Shaft taper 1 : 12, housing H7.

## Lubrication, sealing

During mounting, the cavities of the spherical roller bearings and housings are completely filled with lithium soap base *grease* of *consistency* number 2 which contains *EP additives*.

### Rudder shaft bearing FAG RS3052KS.1.....

The bearing is *grease* lubricated. It sits in the pot-like housing which is attached to the housing base plate by sturdy webs. A stuffing box *seal* is mounted in this base plate. Its packing runs on a sleeve of seawater-resistant steel.

Due to the separation between the upper half and the base any spray water which could penetrate runs along the side and does not get into the rolling bearing. The stuffing box can be inspected at any time during operation and if necessary readjusted. The bottom end of the bearing is provided with a spring seal. A felt seal and V ring suffice for *sealing* at the top end. This bearing arrangement with stuffing box *seal* is maintenance-free.

### Rudder shaft bearing FAG RS3052KW.1.....

Bearing and seal are in one and the same housing and are lubricated with *grease*. The bearing arrangement can also be below the waterline. *Sealing* consists of three seawater-proof shaft sealing rings with an intermediate *grease* chamber. An automatic grease pump holds the latter under permanent pressure.

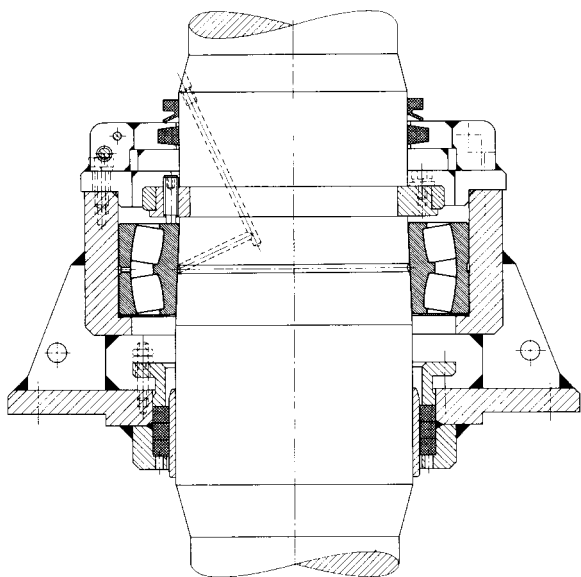

56: Rudder shaft bearing FAG RS3052KS.1.....

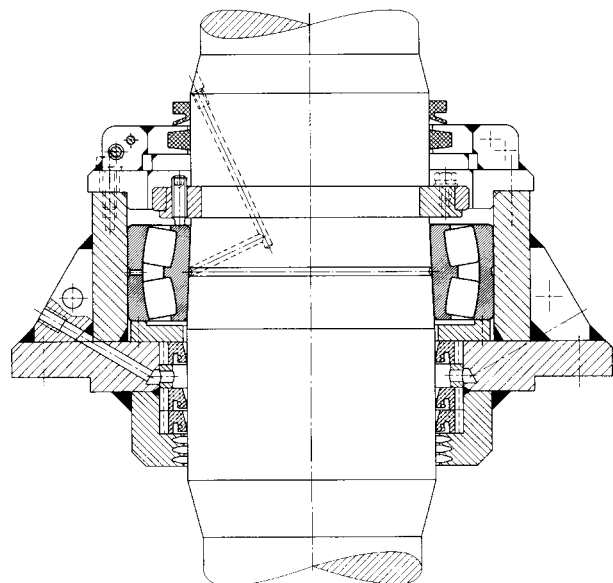

57: Rudder shaft bearing FAG RS3052KW.1.....

# 58–59 Spherical roller thrust bearings as rudder carriers

Spherical roller thrust bearings are used when the top bearing mainly has to take up the weight of the rudder and shaft. This is the case for all rudder drives not loaded by lateral forces, such as for rotary vane steering gears and four-cylinder engines, which do not operate spade-type rudders.

The two designs, N and W, for rudder carriers, differ only in their *sealing*.

## Bearing selection, dimensioning

The shaft diameter is determined according to formulae of the Classification Societies. Thus the bore diameter of the rolling bearing is fixed. Due to the high axial load carrying capacity a spherical roller thrust bearing FAG 29284E.MB with the dimensions 420 x 580 x 95 mm is mounted directly on the shaft. The bearing's *index of static stressing*  $f_s \geq 10$ .

The welded housings are extraordinarily flat – they protrude just slightly beyond the deck or mounting base. This provides advantages especially for larger steering engines, since the rudder shaft extension can be kept short due to the low mounting and dismounting height.

Powerful springs under the bearing outer ring provide a permanent positive contact of rollers and raceways. The supplementary plain bearing also accommodates radial forces, if for example a cylinder in a four-cylinder steering engine fails.

## Machining tolerances

Shaft h7. The housing is relief turned to ensure axial spring preload via the housing washer.

## Lubrication, sealing

During mounting, the cavities of the spherical roller thrust bearings and housings are completely filled with lithium soap base *grease* (*consistency* number 2 with *EP additives*). As with radial spherical roller rudder bearings, there are also two designs (N and W) in the case of rudder carrier bearings. Only the *seal* differs: FAG RS9284N.1..... rudder carrier bearings have felt seals, the rudder carrier bearings FAG RS9284W.1..... are sealed with seawater-proof shaft sealing rings. Both designs have a V-ring *seal* at the housing cover.

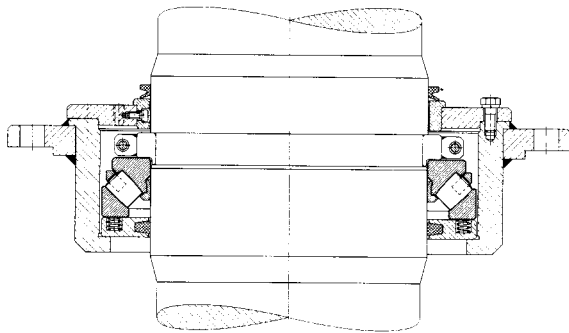

58: Rudder carrier bearing FAG RS9284N.1.....

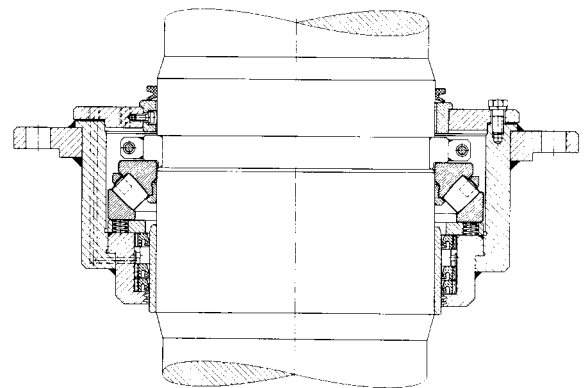

59: Rudder carrier bearing FAG RS9284W.1.....

---

# 60 Spade-type rudder

---

## Design

The slewing motion is accommodated by a top bearing and a bottom bearing. Both bearing locations are equipped with rolling bearings since they are inside the ship's hull. The top bearing or rudder carrier is designed as the *locating bearing* due to the locating ring between cover and bearing outer ring. The bottom bearing is the floating bearing. Spherical roller bearings are used at both locations and the bearing arrangement is therefore statically defined and not affected by misalignment of housing bores, warping of the ship's hull and rudder shaft deformation. Both spherical roller bearings are mounted on adapter sleeves which are mounted and dismantled by means of the hydraulic method. The relevant adapter sleeves (HG design) have connecting holes and grooves for the pressure oil.

## Operating data

Top bearing:  
Axial load 380 kN (weight of rudder and shaft).  
Radial load 1,700 kN (load from rudder and steering engine).

Bottom bearing:  
Radial load 4,500 kN (load from rudder and steering engine).

## Bearing selection, dimensioning, sealing

Bearing selection is based on the specified shaft diameter and the given loads. Since the bearings only make slewing motions they are selected according to their static load carrying capacity. An *index of static stressing*  $f_s \geq 4$  is a must.

The bottom spherical roller bearing, an FAG 230/750K.MB.R60.210 (or 230/750K.MB.C2), is located on an adapter sleeve FAG H30/750HG. Since this bearing is permanently below the waterline, special *sealing* must be provided for the shaft passage.

The radial *sealing* rings run on a sleeve made of sea-water-resistant steel. The lips form a grease chamber permanently pressurized by an automatic grease pump. Some of the *grease* (lithium soap base grease of the *consistency* number 2 with *EP additives*) penetrates into the housing keeping the initial grease packing under constant pressure.

The *seal* above the bearing (shaft sealing ring and V ring) protects it against water which may either run down the shaft or collect in the rudder trunk.

The top spherical roller bearing, an FAG 23188K.MB.R50.130 (or 23188K.MB.C2), is mounted on the shaft with an adapter sleeve FAG H3188HG. The adapter sleeve is fixed axially; below by the shaft shoulder and above by a split holding ring which is bolted into a circular groove in the shaft. This upper bearing also takes up the weight from rudder and shaft as well as the radial loads. A shaft sealing ring is fitted at the upper and at the lower shaft diameter for *sealing* purposes. There is also a V ring at the upper shaft passage.

When relubricating with an automatic grease press, the initial *grease* filling is kept under pressure and the seal rings are lubricated at the same time.

## Machining tolerances

Rudder shaft h8, cylindricity tolerance IT5/2 (DIN ISO 1101). Housing H7.

## Bearing clearance

The bearings have a particularly small *radial clearance*: the lower bearing has 60 to 210 microns or 390 to 570 microns and the upper bearing has 50 to 130 microns or 230 to 330 microns. During mounting, the bearings are pressed onto the adapter sleeve so far that they obtain a preload of 20 to 30 microns. With these preloaded bearings vibrations are easily accommodated.

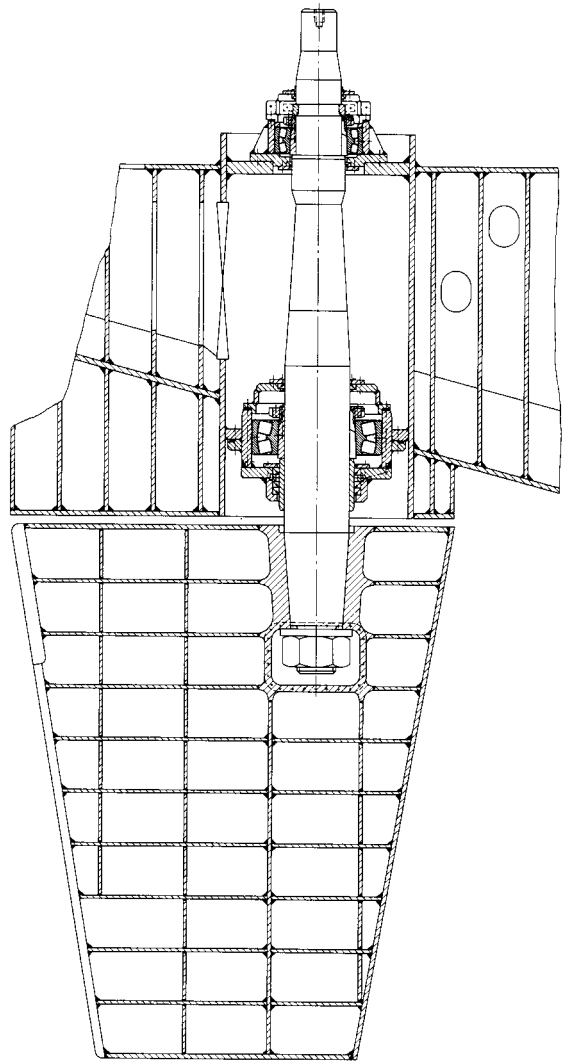
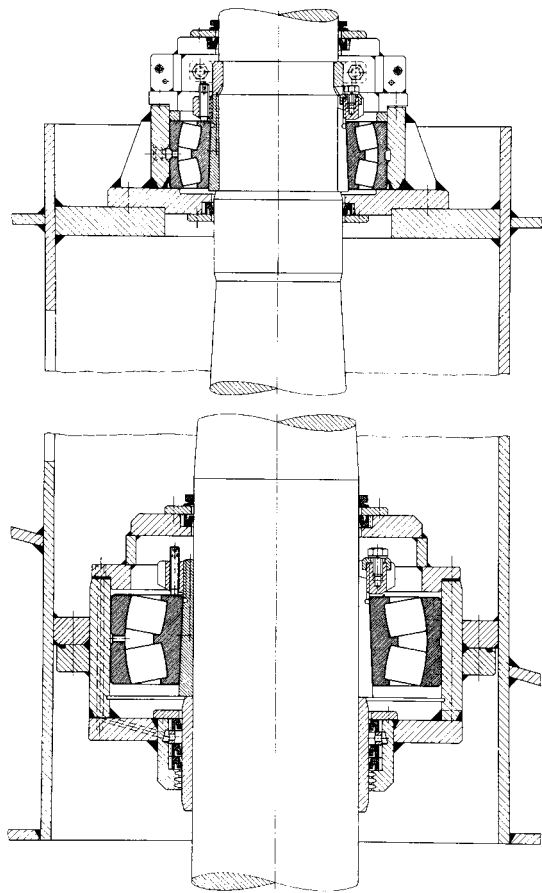

60: Spade-type rudder bearings

# 61–62 Ship shaft bearings and stern tube bearings

The propeller shaft of a ship is carried by so-called support bearings. Since length variations of the shaft are considerable, particularly with long shafts, the bearings must have axial freedom. The last part of the shaft supporting the propeller, runs in the so-called stern tube or tail shaft bearings.

## Operating data

Shaft diameter 560 mm; nominal speed of propeller shaft  $105 \text{ min}^{-1}$ .

Radial load from shaft and coupling 62 kN, no axial load – the propeller thrust is taken up by the propeller thrust block (figs. 63 and 64). With a supplementary factor of 100 % on the radial load ( $f_z = 2$ ), shocks or other dynamic forces are sufficiently taken into consideration when determining the bearing stress.

## Bearing selection, dimensioning, sealing

Since the diameter of the ship shaft is specified, the bearings are overdimensioned for the loads to be accommodated. Thus the *index of dynamic stressing*  $f_L$  ranges from 4 to 6 and therefore a high *nominal life* ( $L_h$ ) is obtained. With very good cleanliness in the lubricating gap, *endurance strength* is reached in the *adjusted life calculation* ( $L_{hna}$ ) for ship shaft and stern tube bearings.

A spherical roller bearing FAG 239/600BK.MB (dimensions 600 x 800 x 150 mm, *dynamic load rating*  $C = 3,450 \text{ kN}$ ) is used as ship shaft bearing. By means of the hydraulic method the bearing is attached to the shaft with an adapter sleeve FAG H39/600HG and is located in a plummer block housing FAG SUC39/600H.1..... (fig. 61a). The housing is made of grey cast iron GG-25 and consists of a unsplit housing body with two split covers.

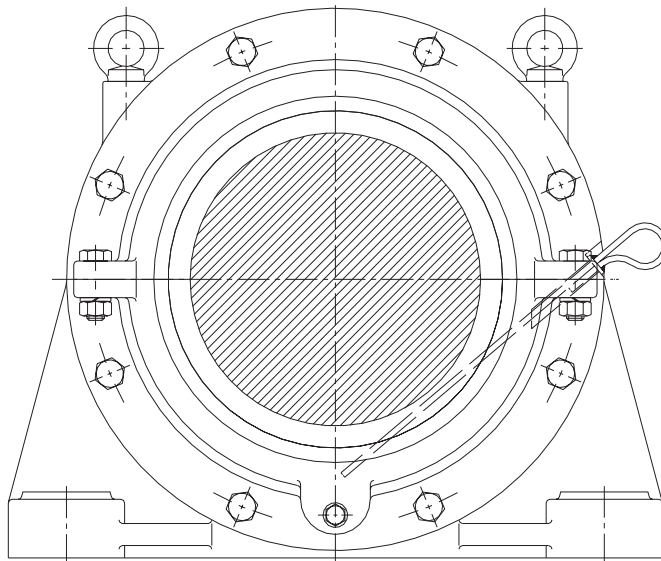

61a: Ship shaft bearing; spherical roller bearing in SUC housing

The housing's *sealing* is provided for by the radial shaft sealing rings in the cover. For small quantities, welded housings are generally more economical than cast housings. Fig. 61b is an alternative ship shaft bearing arrangement made up of a spherical roller bearing FAG 23048K.MB with adapter sleeve H3048 and a split plummer block housing S3048KBL.1..... (material GG-25).

The ship shaft is surrounded by the stern tube at the stern. Fig. 62 shows a stern tube bearing arrangement, both bearings are designed as *floating bearings*. The tail bearing is also loaded by propeller weight and wave action. Spherical roller bearings are applied here also whose inner rings, with adapter sleeves, are attached to the shaft. A special stern tube *sealing* protects the bearings from seawater.

## Machining tolerances

The inner rings carry *circumferential load*.

Adapter sleeve seat on the shaft h8. Cylindricity tolerance IT5/2 (DIN ISO 1101); housing bore H7.

Flanged housings are used for the tail shaft bearings.

## Lubrication

The bearings are lubricated with a non-aging *oil* with *EP additives* (*viscosity* 150 to 300  $\text{mm}^2/\text{s}$  at  $40^\circ\text{C}$ ). The lower parts of the support bearing housings have viewing glasses or oil dip sticks on which the permissible maximum and minimum oil levels are marked. The stern tube is filled with *oil*. The oil pressure is kept a little higher than that of the surrounding water.

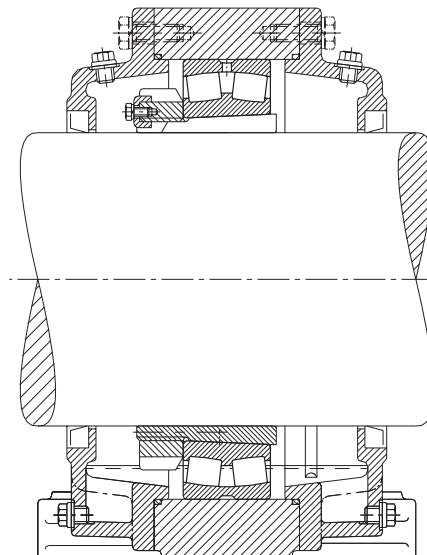

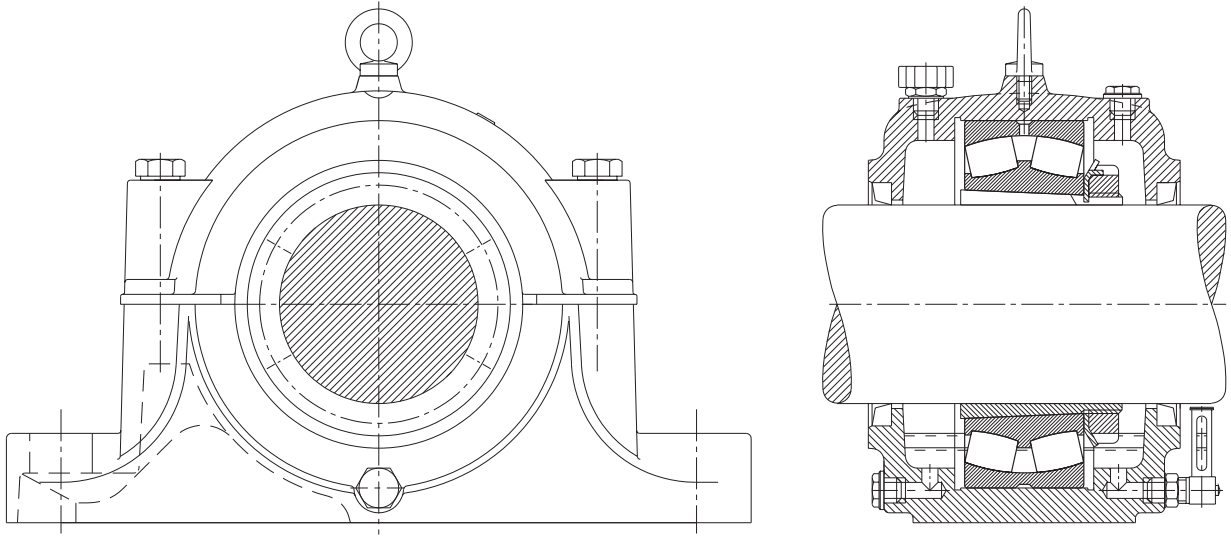

61b: Ship shaft bearing. Spherical roller bearing in S30.K housing

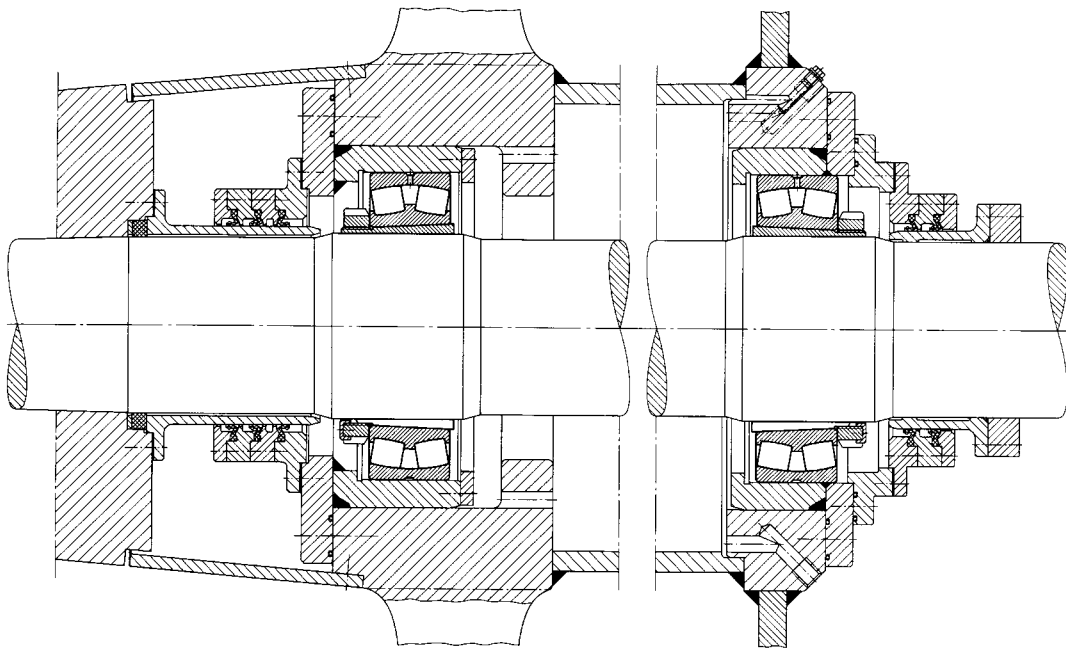

62: Stern tube or tail shaft bearing arrangement

# 63–64 Ship shaft thrust blocks

The thrust block is located directly behind a ship's engine. It transmits the propeller thrust to the ship. Apart from a small radial load from the shaft weight the bearing is loaded by a purely concentric thrust load. Depending on the direction of rotation of the propeller, it acts either forward or backward. During sternway the thrust load is lower and usually occurs only seldom. Three bearing arrangements are commonly used for these requirements:

Fig. 63a illustrates a thrust block arrangement with two spherical roller thrust bearings for small shaft diameters in a SGA plummer block housing.

Fig. 63b illustrates a thrust block arrangement with two spherical roller thrust bearings and one radial spherical roller bearing in an FKA flanged housing.

Both bearing arrangements are used when the axial load carrying capacity of a radial spherical roller bearing is insufficient when sternway is very frequent. The spherical roller thrust bearings accommodate the propeller thrust during forward motion and the propeller pull during sternway. In 63a the *thrust bearings* accommodate the weight also while in 63b the weight of shaft and propeller is supported by a radial spherical roller bearing.

Fig. 64 shows ship shaft thrust blocks each with a spherical roller thrust bearing and a radial spherical roller bearing:

a: – in SGA housing, b: – in SUB housing

The curvature centres of the outer ring raceways of the radial and axial bearings coincide. The bearings are therefore *self-aligning* and thus misalignment and bending of the shaft and hull are compensated for. In these thrust blocks only the propeller thrust is accommodated by the spherical roller thrust bearing during forward motion. The radial spherical roller bearing transmits the weight of the shaft and the propeller pull during sternway. The spherical roller thrust bearing not under stress is preloaded by springs so that it does not lift during sternway. A constant axial minimum load is thus ensured.

## Machining tolerances

Fig. 63a:

Spherical roller thrust bearing Shaft m6; housing H7

Fig. 63b:

Spherical roller thrust bearing Shaft n6; housing relief turned

Radial spherical roller bearing Shaft n6; housing F7

Fig. 64a, 64b:

Spherical roller thrust bearing Shaft m6; housing relief turned

Radial spherical roller bearing Shaft m6; housing H7

## Dimensioning of bearings

The diameter of the thrust block shaft is determined according to the guidelines of the Classification Societies. Taking the power output into account the *nominal life*  $L_n$  [h] and the resulting *index of dynamic stressing*  $f_L$  are calculated. An  $f_L$  value of 3 – 4 is recommended for the rolling bearings in ship shaft thrust blocks. Particularly with utmost cleanliness in the lubricating gap, ship shaft thrust blocks reach *endurance strength* according to the *adjusted life calculation*.

## Design

Ship shaft thrust blocks are supplied as complete units FAG BEHT.DRL. The unit includes bearings, housing with *sealing* and thrust block shaft with loose flange. The FAG thrust block housings are supplied either in split design SGA (figs. 63a and 64a) or in unsplit design FKA (fig. 63b) or SUB (fig. 64b).

### Order example for unit

**FAG BEHT:GRL:110.156680, consisting of:**

1 Plummer block housing FAG SGA9322.156678

1 Thrust block shaft with loose flange

FAG DRW110 x 610.156678

2 Spherical roller thrust bearings FAG 29322E

1 Locknut FAG KM26

1 Lock washer FAG MB26

*Oil* lubrication

## Operating data

	63a: Ship shaft thrust block FAG BEHT.DRL110.1..... with 2 spherical roller thrust bearings	63b: Ship shaft thrust block housing FAG FKA94/600.1 2 spherical roller thrust bearings 1 radial spherical roller bearing	64a, b: Ship shaft thrust block FAG BEHT.DRL.200.1..... with 1 spherical roller thrust bearing 1 radial spherical roller bearing
Diameter of thrust block shaft	110 mm	600/510 mm	200 mm
Power	320 kW	11,400 kW	1,470 kW
Speed	800 min <sup>-1</sup>	150 min <sup>-1</sup>	500 min <sup>-1</sup>
Thrust	55 kN	1,625 kN	170 kN
Forward motion	50 %	50 %	95 %
Sternway	50 %	50 %	5 %
Bearings mounted	<b>2 x FAG 29322E</b>	<b>1 x FAG 239/600B.MB.C3</b> <b>2 x FAG 294/600E.MB</b>	<b>1 x FAG 23140B.MB</b> <b>2 x 29340E</b>
Lubrication	<i>Oil</i> sump lubrication <sup>1)</sup>	<i>Oil</i> sump lubrication <sup>1)</sup>	<i>Oil</i> sump lubrication <sup>1)</sup>
Sealing	Shaft sealing rings	Shaft sealing rings	Shaft sealing rings

<sup>1)</sup> Non-aging *oil* with pressure *additives* (viscosity 150 to 300 mm<sup>2</sup>/s at 40°C)

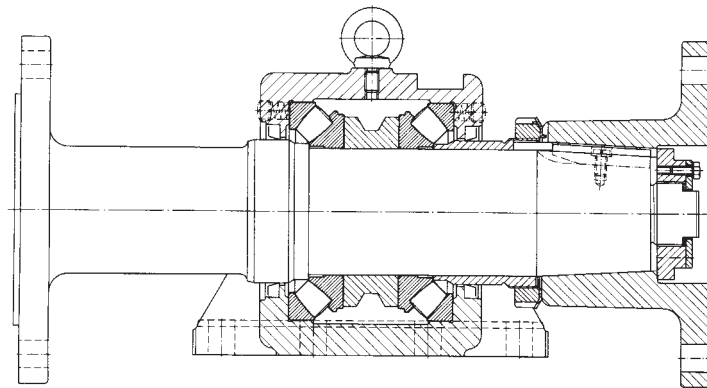

63a: Complete ship shaft thrust block FAG BEHT.DRL.110.1..... (SGA plummer block housing)

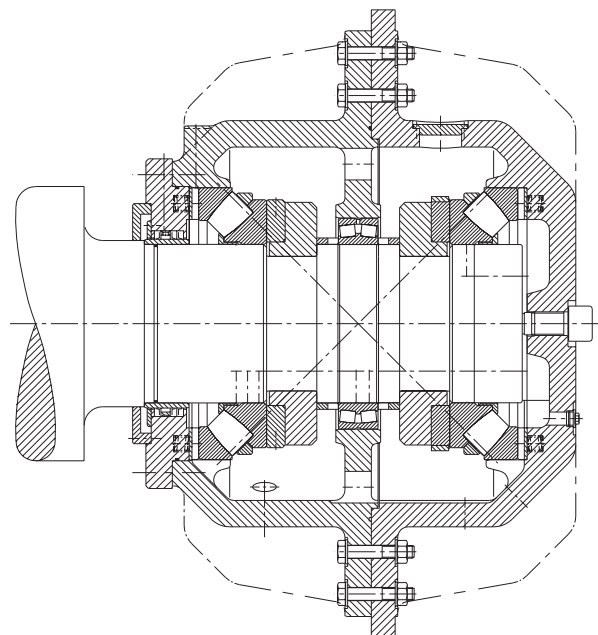

63b: Ship shaft thrust block with FKA flanged housing

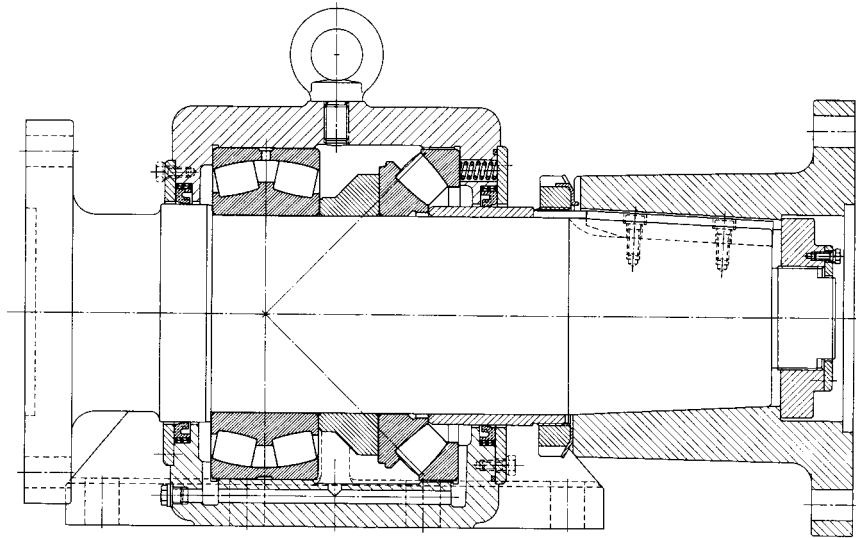

64a: Complete ship shaft thrust block FAG BEHT.DRL.200.1..... (SG A plummer block housing)

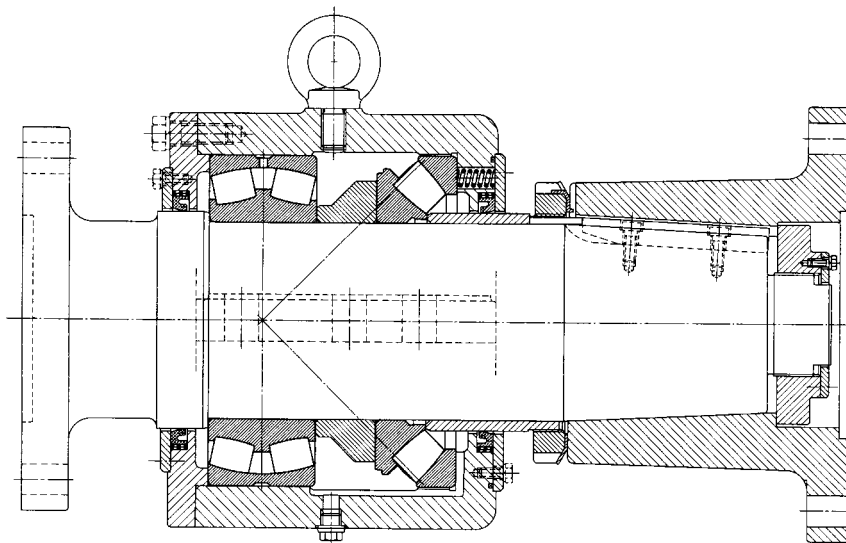

64b: Complete ship shaft thrust block FAG BEHT.DRL.200.1..... (SUB pot-shaped housing)

# 65–72 Paper Machines

Modern paper machines are extensive plants which frequently stretch well beyond 100 m in length and have numerous rolls. The demand for utmost operational reliability is priority number one when designing and dimensioning bearing locations: if trouble arises at just one roll the whole plant has to be shut down. For this reason the bearings are designed for a far longer *nominal life* (*index of dynamic stressing*  $f_L = 5 \dots 6$ ) than in other industrial equipment. A high degree of cleanliness in the bearings is decisive for a long *service life*. This demands utmost *sealing* reliability, particularly against moisture, and design diversity based on the type of roll in question.

Lubrication also influences the *bearing life* greatly. All roll bearings in modern paper machines are connected to an *oil* circulation system for operational reliability and maintenance purposes. The bearings in the wet end section of older paper machines are still lubricated with *grease* (lower environmental temperatures).

In the dryer section, bearings for rope sheaves, spreader rolls and sometimes guide rolls are still lubricated with *grease*.

Due to high temperatures in the area of the dryer roll, bearing lubrication is particularly critical. Therefore *oils* of the *viscosity class* ISO VG 220 or 320 are used. Lightly doped *mineral oils* and *synthetic oils* are suitable (high ageing stability), which correspond to the requirements for dryer roll oils and have proven themselves in the field or successfully stood dynamic testing on the FAG test rig FE8.

Lubrication can be improved considerably (increasing the *operating viscosity*) by insulating the hollow journals of the dryer rolls and thus reducing the bearing temperature.

The following examples show the structure of some main bearing locations in the paper industry, for example refiners, suction rolls, press rolls, dryer rolls, guide rolls, calender thermo rolls, anti-deflection rolls and spreader rolls.

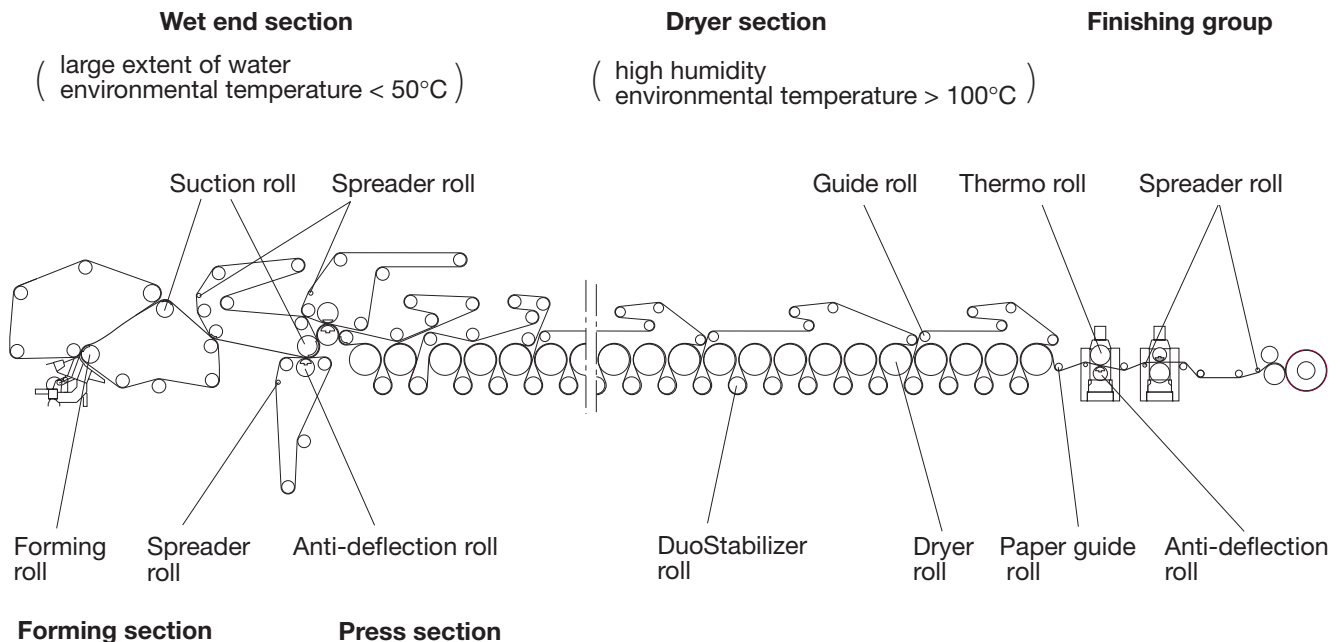

A modern paper machine

Wood chips from the wood chopper which have been softened and steamed by water are broken down and crushed in the refiner by means of crushing wheels rotating in reverse motion with knife sections. Temperatures up to 160 °C result from this process (steamed wood chips, crushing) and can lead to increased operating temperatures in bearings depending on their construction.

## Operating data

Axial load from crushing process 400 kN;  
Radial load (rotor/shaft) 15 kN per bearing;  
Speed 600 min<sup>-1</sup>;  
Temperature in locating bearing 80 °C, in floating bearing 70 °C.

## Bearing selection, dimensioning

With the high axial loads which have to be accommodated, an *attainable life*  $L_{hna} \geq 80,000$  hours is required. A second thrust bearing is necessary since the axial load acts mainly in the direction of the *locating bearing* but can also be acting in the opposite direction. Thus the *locating bearing* arrangement is made up of two symmetrically arranged spherical roller thrust bearings FAG 29460E. For the rollers to remain undisturbed when the axial load is "reversed" both bearings must be preloaded with springs (minimum load) at the outer rings.

A spherical roller bearing FAG 23052K.MB is mounted as a *floating bearing* and can easily accommodate shaft deflection. Thermal length variations of the shaft are compensated for in between bearing outer ring and housing (sliding fit). The bearing is mounted directly on the tapered shaft seat and fastened with a locknut HM3052.

The *floating bearing* reaches a *nominal life*  $L_h$  of well over 200,000 hours. Excellent bearing lubrication is required due to slippage hazard when loads are low ( $P/C \approx 0.02$ ).

A *nominal life* of  $L_h = 50,600$  h is calculated for the left *locating bearing* 29460E. With *oil* circulation lubrication, good cleanliness and a bearing temperature of 70 °C, factor  $a_{23}$  is 3.2. An *attainable life*  $L_{hna} = 162,000$  h results from the *adjusted life calculation*.

The right *locating bearing* only has a slight axial load (spring preload). The *attainable life*  $L_{hna}$  is over 200,000 h for this bearing.

## Machining tolerances

*Floating bearing:* The inner ring has *circumferential load* and is attached to the tapered bearing seat of the shaft.

Roundness tolerance IT5/2 (DIN ISO 1101);

Taper angle tolerance AT7 (DIN 7178).

Bearing seat of housing bore according to G7.

*Locating bearing:* For mounting reasons, both shaft and housing washer are in sleeves. The bearing seats are machined according to k6 and G7 for the shaft sleeves and housing sleeves respectively.

## Lubrication

A *lubricating oil* ISO VG 150 with *EP additives* is used for *locating* and *floating bearings*.

The radial spherical roller bearing has oil circulation lubrication with 0.8 l/min. Oil jet lubrication is provided for the spherical roller thrust bearings. This ensures adequate *oil* constantly at the highly-stressed contact areas between roller face and lip. The *oil* is supplied through the side of the bearing via the spacer sleeve. The minimum *oil* flow rate for both bearings is 8 l/min (good heat dissipation from bearing). The oil is filtered in circulation and cooled back to a temperature of 40 °C.

## Sealing

There are two labyrinths on the side of the crushing wheel connected to one another and filled with grease which protect the bearings from water and contamination and prevent *oil* escaping from the bearings. On the outer side of the *locating bearing* a shaft sealing ring prevents *oil* escape.

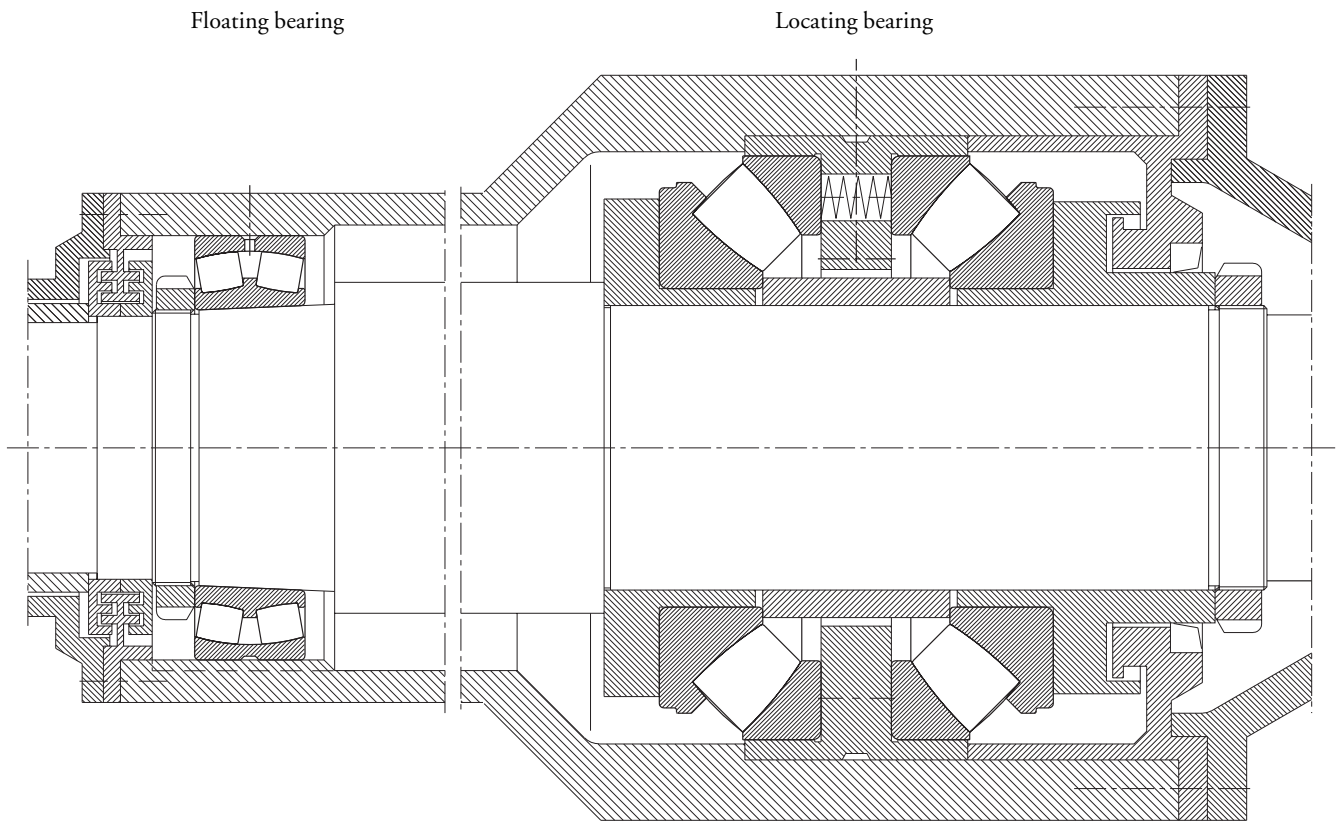

# 66 Suction rolls

Suction rolls are found in the wire or press section of a paper machine. They are hollow cylinders up to 10 m in length which have several small holes all around their circumference. Some water is removed from the web due to the rotating roll shell and the vacuum inside the roll. The suction box, as interior axle, is stationary. The roll shell is driven by planet wheels in modern paper machines.

## Operating data

Roll length 7,800 mm; roll diameter 1,600 mm; rotation  $278 \text{ min}^{-1}$  (speed 1,400 m/min); roll weight 270 kN; wire tension 5 kN/m.

## Bearing selection, dimensioning

The diameter of the suction box is decisive for the size of the bearing. We recommend bearings with a *dynamic load rating* as low as possible; the higher specific bearing load reduces the danger of slippage. *Self-aligning bearings* are necessary as misalignment could arise. Roll weight, wire tension and rotational speed are the main criteria for dimensioning the bearings.

FAG spherical roller bearings FAG 239/850K.MB.C3 with tapered bore (K 1:12) and increased *radial clearance* are used. The bearings are mounted directly on the tapered shaft seats for running accuracy reasons. The hydraulic method is applied to facilitate mounting.

The *locating bearing* provides axial guidance for the rolls while the *floating bearing* compensates for any

length variations caused by displacement of the outer ring in the housing bore.

The *nominal life* for both bearings is  $L_h > 100,000 \text{ h}$ . The *attainable life* reaches over 200,000 h when the operating temperature is  $60 \text{ }^\circ\text{C}$  and *oil* ISO VG 68 (*viscosity ratio*  $\kappa > 2$ ; *factor*  $a_{23} = 2.2$ ) is used.

## Machining tolerances

The inner ring has *circumferential load* and is attached to the tapered bearing seat of the shaft.

Roundness tolerance IT5/2 (DIN ISO 1101); taper angle tolerance AT7 (DIN 7178).

Housing bores according to G7 due to *point load* at the outer ring.

## Lubrication

The spherical roller bearings are supplied by circulation lubrication with a *mineral oil* quantity of 8 l/min. A *mineral oil* with sufficient *viscosity* and *EP additives* is selected. *Additives* with good anti-corrosive properties and water separation ability are also required. An effective lubrication is achieved with an oil supply to the centre of the bearing.

## Sealing

Any *oil* which escapes is thrown off via splash grooves into oil collecting chambers and directed back. At the roll side a baffle plate and multiple grease-filled labyrinth with integrated V ring prevent water penetrating from the outside.

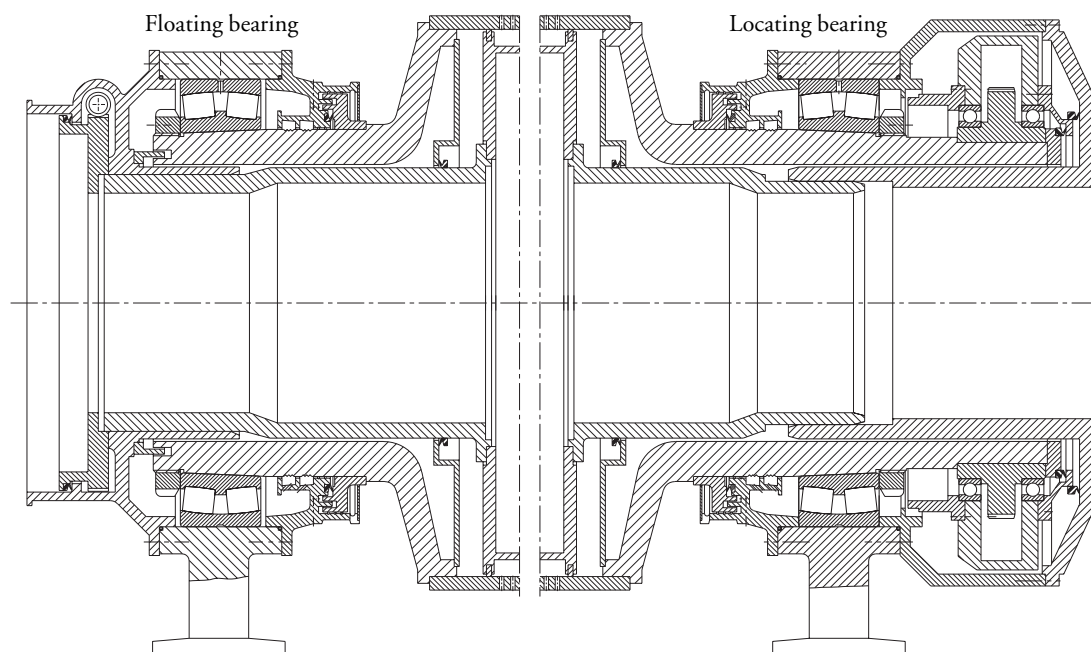

66: Suction roll bearings

# 67 Central press rolls

The paper web runs through the press rolls on a felt cloth and a large amount of water is pressed out of it. Modern press sections consist of one central press roll against which one or more (suction) press rolls are pressed. The central press roll is solid, made of granite/steel or steel with a protective coating.

## Operating data

Roll length 8,800 mm; roll diameter 1,500 mm; speed 1,450 m/min; roll weight 750 kN. Pressure by 3 rolls at 30°, 180° and 210°; bearing temperature about 60 °C. Direct drive.

## Bearing selection, dimensioning

*Self-aligning* spherical roller bearings of the series 231 or 232 with a very high load carrying capacity are chosen due to the high radial load and the misalignment which is possible between the bearing locations. A low cross section height is also important for these bearings since the height of the housing is restricted by the roll diameter. The roll weight and the load components of the pressure rolls yield a resulting bearing load  $F_r = 300$  kN.

A spherical roller bearing FAG 231/600K.MB.C3 is mounted at every bearing location. The bearings with tapered bore (taper 1:12) are pressed directly onto the tapered shaft seat by means of the hydraulic method. The *floating bearing* at the operator's end permits temperature-depending length variations of the roll by shifting the outer ring in the housing. The *locating bearing* is at the drive end.

The *nominal life* calculated is  $L_h > 100,000$  h with a speed of  $308 \text{ min}^{-1}$ . With good lubrication (*viscosity ratio*  $\kappa \approx 3$ , *basic factor*  $a_{23II} = 3$ ) and improved cleanliness (*contamination factor*  $V = 0.5$ ) in the lubricating gap  $L_{hna} \geq 100,000$  h according to the *adjusted rating life calculation*.

## Machining tolerances

The inner ring has *circumferential load* and is attached to the tapered bearing seat of the shaft. Roundness tolerance IT5/2 (DIN ISO 1101); taper angle tolerance AT7 (DIN 7178). Housing bores according to G7 since there is *point load* at the outer ring.

## Lubrication

The spherical roller bearings are supplied with a minimum *oil* quantity of 7 l/min by circulation lubrication. A *mineral oil* of sufficient *viscosity* (ISO VG 100) and *EP additives* is used. *Additives* with good anti-corrosive properties and water separation ability are also required. An effective lubrication is achieved with an oil supply to the centre of the bearing. Oil returns to both sides of the bearing via oil collecting pockets and connecting holes.

## Sealing

Oil splash grooves in the roll journal prevent *oil* escaping at the cover passage. Non-rubbing and maintenance free gap-type *seals* protect the bearings from environmental influences.

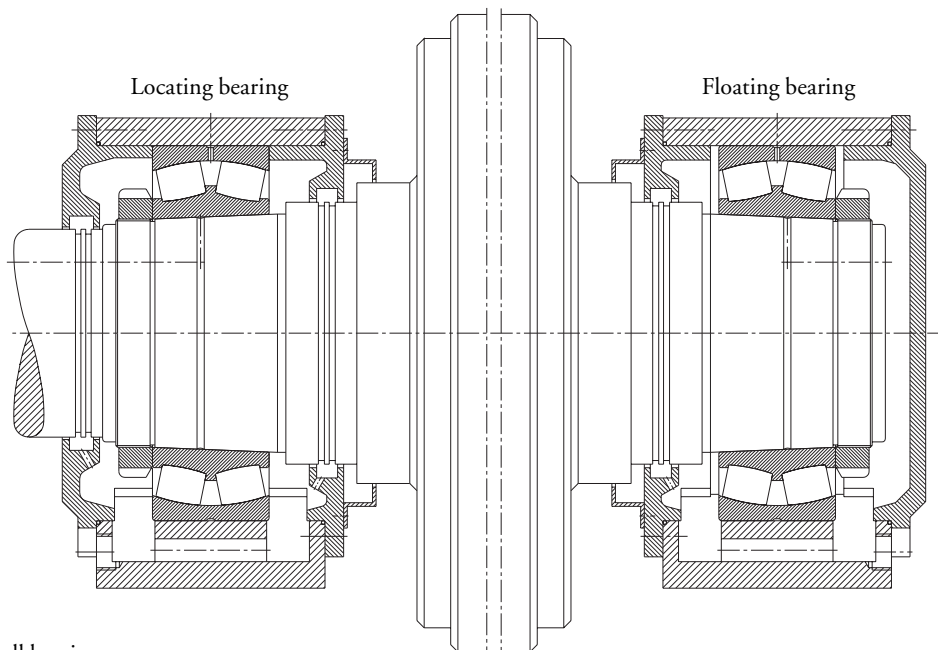

67: Central press roll bearings

# 68 Dryer rolls

The remaining water in the dryer section is evaporated. The paper runs over numerous heated dryer rolls guided by endless dryer wires (formerly dryer felts). The dryer rolls are steam heated (temperature depends on the type of paper, its thickness and speed, and on the number of dryer rolls). The high temperatures of the heating steam transfer to the bearing seats stressing the rolling bearings accordingly. Today, the journals through which the steam flows are insulated in order to keep bearing temperatures low.

## Operating data

Working width 5,700 mm; roll diameter 1,800 mm; paper speed 1,400 m/min (rotational speed  $248 \text{ min}^{-1}$ ); heating temperature  $165 \text{ }^\circ\text{C}$  (7 bar); roll weight 90 kN. Felt pull  $4.5 \text{ kN/m}$ ; wrap angle  $180^\circ$ ; environmental temperature under the dryer section hood approx.  $95 \text{ }^\circ\text{C}$ ; insulated journal bores.

## Bearing selection

The bearing load is calculated from the roll weight, felt pull and temporary water fill. *The floating bearing* is loaded with 75 kN, the *locating bearing* with 83 kN taking into account the drive force. Heating the dryer roll leads to heat expansion which in turn leads to considerable changes in length with such long rolls. *Self-aligning* rolling bearings are necessary due to the misalignment arising between both bearing locations. A double-row cylindrical roller bearing of the dimension series 31 is provided as *floating bearing* at the operator's end. It easily compensates for length variations in the bearing between the rolls and the inner ring raceway. With its spherical sliding surface a plain spherical bearing's seating ring accommodates any alignment inaccuracy of the journal. A double-row self-aligning cylindrical roller bearing FAG 566487K.C5 with the dimensions  $200 \times 340 \times 112 \text{ mm}$  is mounted. A spherical roller bearing FAG 23140BK.MB.C4 is mounted as *locating bearing* on the drive end.

Both bearings have about the same *operating clearance* in order to avoid any detrimental preload during the heating-up stage which may lead to a maximum temperature difference of 50 K. The spherical roller bearing has an increased *radial clearance* according to C4 (260...340 microns), the cylindrical roller bearing an increased *radial clearance* according to C5 (275...330 microns).

Both bearings have a tapered bore (K 1:12) and are mounted by the hydraulic method directly onto the tapered journals.

Since the cylindrical roller bearing and the spherical roller bearing have the same dimensions unsplit PMD plummer block housings (FAG PMD3140AF or BF) are applied both at the drive end and at the operator's end.

Due to increased operating temperature, both bearings are given special heat treatment (isotemp) and are thus dimensionally stable up to  $200 \text{ }^\circ\text{C}$ .

## Bearing dimensioning

An *attainable life*  $L_{\text{hna}} \geq 250,000$  hours is required for dryer roll bearings. Lubrication decisively influences the *adjusted rating life*. Under an average operating temperature of  $100^\circ\text{C}$  the *operating viscosity*  $\nu \approx 16 \text{ mm}^2/\text{s}$  for a *mineral oil* with a nominal *viscosity* of  $220 \text{ mm}^2/\text{s}$  (ISO VG 220).

The *rated viscosity* is determined from the speed and the mean bearing diameter  $d_m = (200 + 340)/2 = 270 \text{ mm}$  to  $\nu_1 = 25 \text{ mm}^2/\text{s}$ .

The *viscosity ratio* is then:

$$\kappa = \nu/\nu_1 = 16/25 = 0.64.$$

With the *value*  $K = 1$  a *basic factor*  $a_{23\text{II}} = 1.1$  is obtained for the spherical roller bearing.

The values  $K = 0$  and  $a_{23\text{II}} = 1.4$  apply to the cylindrical roller bearing.

With normal cleanliness (*cleanliness factor*  $s = 1$ ) the *factor*  $a_{23} = a_{23\text{II}} \cdot s$

1.1 for the spherical roller bearing,

1.4 for the cylindrical roller bearing.

The *attainable life*  $L_{\text{hna}} = a_1 \cdot a_{23} \cdot L_h$  is therefore well over 250,000 h for both bearings.

## Machining tolerances

The inner rings have *circumferential load* and have a tight *fit* on the tapered roll journal. The journals have oil ducts so the bearings can be mounted and dismounted by means of the hydraulic method. Roundness tolerance IT5/2 (DIN ISO 1101), taper angle tolerance AT7 (DIN 7178). Bearing seats in the housing bore according to G7.

## Lubrication

The bearing housings are connected to a central *oil* circulation lubrication system so that heat is constantly dissipated from the bearing. High-grade *mineral oils* ISO VG 220 or 320 are used which must have a high *operating viscosity*, thermal stability, good protection against *wear*, good water separation ability and a high degree of cleanliness. A minimum *oil* quantity of 1.6 l/min is guided directly to the centre of the bearing via a lubricating groove and lubricating holes in the outer ring.

The oil can be carried off at both sides of the bearing with the central oil system. The danger of oil retention

and leakage is minimized considerably. Any contaminants or *wear* particles which might penetrate the bearing are immediately washed out of it with this method of lubrication.

## Sealing

Gap-tape *seals*, which are non-rubbing and maintenance-free, are provided as *sealing* for the journal passages. The *oil* is thrown off via splash grooves and *oil* collecting chambers and flows back through return holes to the two *oil* cavities on the housing floor. Cover *seals* make the housing of the paper machine *oil*proof.

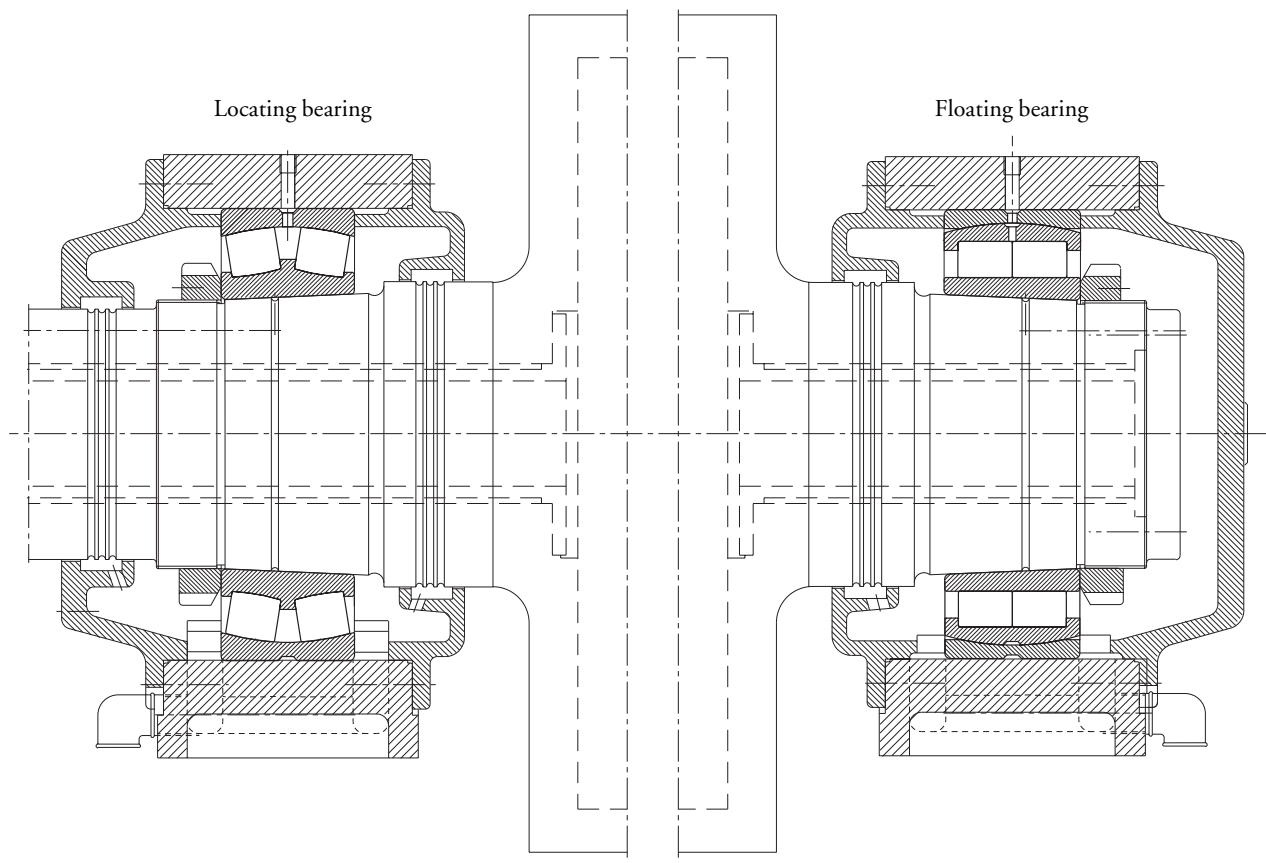

# 69 Guide rolls

Guide rolls guide, as the name indicates, and turn the wire and felt cloth in the wet end and dryer sections of a paper machine. The same bearings are used for the guide rolls in both areas. Lubrication and *sealing* differ, however, depending on the place of application.

In older machines the wet end section is usually lubricated with grease, and the dryer section with *oil*.

In modern machines both sections have *oil* circulation lubrication. Due to different operating conditions separate oil circuits are necessary for the wet end and dryer sections.

The larger the machine the more often it is found to be faster. For this reason the bearing inner rings are mounted with a tapered bore directly on the tapered roll journal.

## *Wet end section*

Depending on the positions of the bearings in the machine they are subject to a small or large degree of moisture. Water must not penetrate the housing particularly when machines are being high-pressure cleaned.

## *Dryer section*

Environmental temperatures of about 95 °C lead to great length variations and place high demands on lubrication. The operating temperature of the bearings can be 115 °C.

## Operating data

Useful width 8,800 mm

Roll diameter 700 mm

Paper speed 1,650 m/min ( $n = 750 \text{ min}^{-1}$ )

Roll weight  $F_G \approx 80 \text{ kN}$

Paper pull 1 kN/m (tensile load  $F_z \approx 9 \text{ kN}$ )

Wrap angle 180°

Bearing temperature approx. 105 °C

## Bearing selection, dimensioning

The bearings must be able to accommodate loads and compensate for misalignment at the same time (misalignment, bending). An increased *radial clearance* according to C3 is necessary due to temperature differences. Spherical roller bearings FAG 22330EK.C3 are mounted.

## Bearing load:

$$P = (F_G + F_z)/2 = (80 + 9)/2 = 44.5 \text{ kN}$$

The diameter of the roll journal is determined by the roll rigidity required. As a result there is a high *index of dynamic stressing*  $f_L$  corresponding to a *nominal life*  $L_h$  of well over 200,000 hours. The *attainable life* is even higher with such good lubrication conditions.

The housings can be in standing or suspended position or can be laterally screwed on. They are designed for *oil* circulation lubrication.

## Machining tolerances

The inner rings have *circumferential load* and are directly fitted to the tapered roll journal. The roll journal have oil ducts so the bearings can be mounted and dismounted with the hydraulic method.

Roundness tolerance IT5/2 (DIN ISO 1101); taper angle tolerance AT7 (DIN 7178).

Bearing seats in the housing bore according to G7.

## Lubrication

In the dryer section: see example 68 (Dryer rolls) since the bearings are connected to the *oil* circuit of the dryer rolls. Minimum flow rate 0.9 l/min.

In the wet end section: see example 66 (Suction rolls) and 67 (Central press rolls), since the bearings are connected to the *oil* circuit of the wet section rolls. Minimum flow rate 0.5 l/min.

## Sealing

Gap-type *seals*, which are non-rubbing and maintenance-free, prevent *oil* from escaping through the cover passages in the dryer section.

The bearings in the wet end section must have relubricatable labyrinth *seals* to prevent water from penetrating. Remaining *oil* is thrown off by splash grooves into collecting chambers and directed back. Cover *seals* make the housing oilproof.

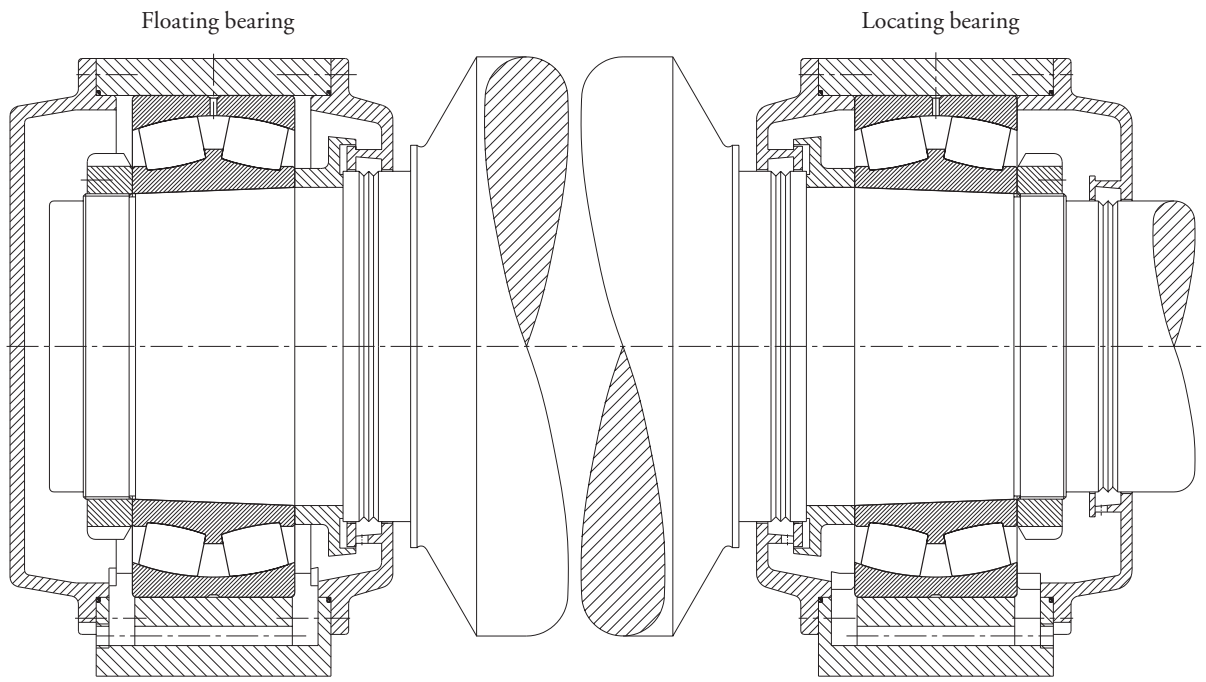

# 70 Calender thermo rolls

The paper passes through the so-called calender stack after leaving the dryer section. Soft calenders smooth the surface of the paper thus improving its printability. The calender consists of two pairs of rolls. One calender roll (steel) lies above a counter roll, another below one. The counter roll is the so-called anti-deflection roll (elastic material). Soft calender rolls can be heated by water, steam, or oil. The gap or the "nip" pressure depends on the type of paper.

## Operating data

Useful width approx. 7 m  
Rotation 350 min<sup>-1</sup> (speed 1,100 m/min)  
Heated by oil at 200...250 °C  
Insulated roll journal  
Operating temperature at bearing inner ring 130 °C.

## Bearing selection, dimensioning

The radial bearing load depends on the application of the calender roll as lower or upper roll, on the weight  $F_G$  and the variable pressure load with percentage of time.

$$\begin{aligned} P_1 &= F_G + F_{\text{nip min}} &&= 600 \text{ kN} \\ P_2 &= F_G + F_{\text{nip med}} &&= 990 \text{ kN} \\ P_3 &= F_G + F_{\text{nip max}} &&= 1,260 \text{ kN} \\ P_4 &= F_G - F_{\text{nip min}} &&= 60 \text{ kN} \\ P_5 &= F_G - F_{\text{nip med}} &&= 390 \text{ kN} \\ P_6 &= F_G - F_{\text{nip max}} &&= 720 \text{ kN} \end{aligned}$$

Percentages of time:  $P_1, P_4$ : 10 % each  
 $P_2, P_3, P_5, P_6$ : 20 % each

The sum of the roll weight and the nip load acts for the application as bottom roll whereas their difference acts for the application as top roll.

Taking the maximum load for designing the bearing would lead to overdimensioning (*equivalent dynamic load*  $P < 0.02 \cdot \text{dynamic load rating } C$ ) in the case of application in the top roll. Slippage may occur with such a low load which in turn can lead to bearing damage when lubrication is inadequate. In order to avoid this problem, smaller bearings with a smaller *dynamic load rating*  $C$  should be selected so that  $P/C > 0.02$ . The risk of breaking through the lubricating film drops with the smaller roller mass.

Requirements with respect to load carrying capacity and *self-alignment* are met by spherical roller bearings. The cross section height of the bearing is limited by the diameter of the roll journal and roll shell. The relatively wide spherical roller bearings FAG 231/560AK.MB.C4.T52BW are mounted. The *nominal life*  $L_h = 83,000$  h with given loads and percentages of time.

With a *lubricating oil* ISO VG 220 the viscosity ratio is  $\kappa = 0.71$  under an operating temperature of 130 °C. An *attainable life*  $L_{\text{hna}} > 100,000$  h is obtained with the *adjusted rating life calculation* (where  $f_{s^*} > 12$ ;  $a_{23II} = 1.2$ ;  $V = 0.5$ ;  $s = 1.6$ ).

The increased *radial clearance* C4 is required due to the danger of detrimental radial preload in the bearing during the heating up phase when the temperature difference is great. With a *speed index*  $n \cdot d_m = 224,000$  min<sup>-1</sup> · mm we recommend bearings with increased running accuracy according to specification T52BW.

## Machining tolerances

The inner rings have *circumferential load* and are directly fitted on the tapered roll journal. The roll journals have oil ducts so that the hydraulic method can be applied for mounting and dismounting the bearings. Roundness tolerance IT5/2 (DIN ISO 1101), taper angle tolerance AT7 (DIN 7178). Bearing seats in the housing boring according to F7.

## Lubrication

*Oil* circulation lubrication with a *synthetic oil* ISO VG 220, suitable in quality, which has stood dynamic testing on the FAG test rig FE8.

By supplying a large amount of *oil* to the centre of the bearing (minimum flow rate 12 l/min) heat dissipation is achieved as well as a low thermal stress of the oil. Any contaminants or wear particles are washed out of the bearing. Oil returns at both sides of the bearing via oil collecting pockets and connecting holes.

## Sealing

Angle rings at the roll side prevent direct oil escape at the cover holes. Remaining oil is thrown off by splash grooves into collecting chambers and directed back. Cover *seals* make the housing oilproof.

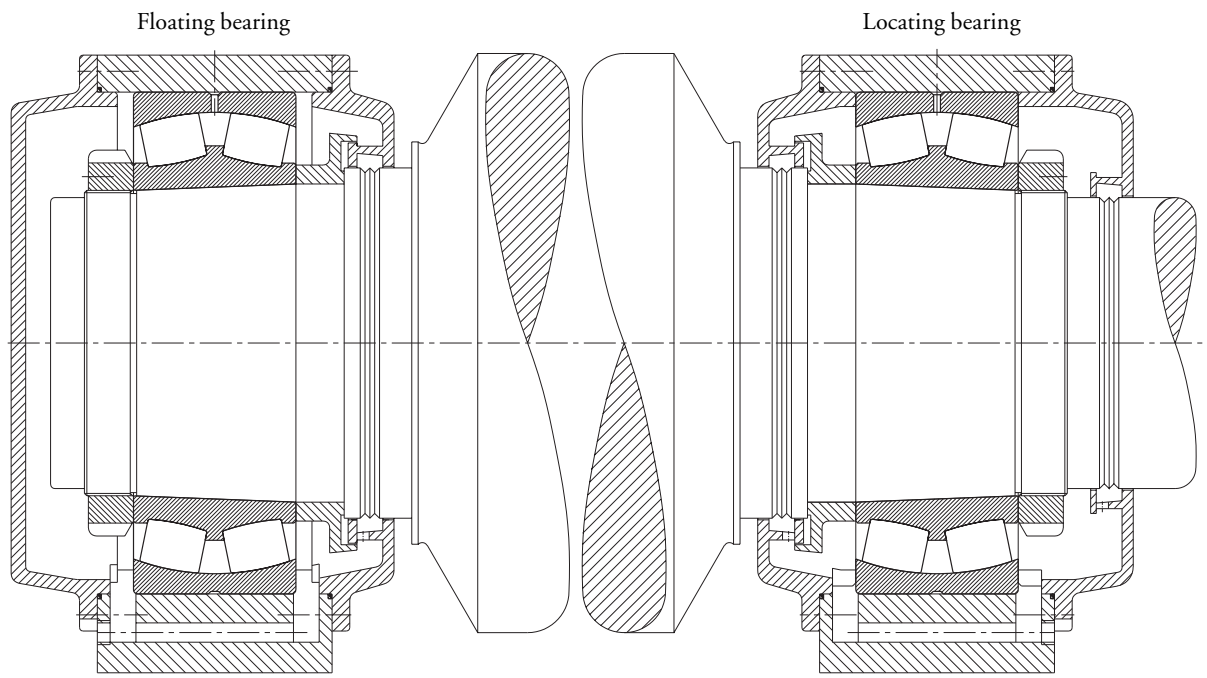

# 71 Anti-deflection rolls

Anti-deflection rolls are found in both the press section and in calenders. They provide for an even paper thickness across the web and a consistently high paper quality. The drive is at the *locating bearing* end. Its power is transmitted via gearing and the hypoid teeth coupling to the roll shell.

The adjustment roll is pressed against the mating roll (calender roll) under very high pressure. As a result the mating roll is bent and the form of the roll shell changed. The shell of the adjustment roll must adjust to this form.

The anti-deflection roll consists of a stationary axle and a rotating roll shell. Control elements which can be pressure-balanced separately are provided on the axle. They support the roll shell hydrostatically and effect its adjustment. The roll shell is shaped like the bent mating roll by the changing pressure giving the paper an even thickness.

## Operating data

Roll length 9,300 mm; roll diameter 1,025 mm; roll weight 610 kN; shell weight 210 kN; pressure 700 kN; circumferential velocity 1,500 m/min ( $n = 470 \text{ min}^{-1}$ ); bearing temperature 55 °C.

## Bearing selection, dimensioning

A *service life* of > 100,000 h is required. The bearing only has a guidance function when in operation (with pressure and closed gap).

Spherical roller bearings FAG 23096MB.T52BW (*dynamic load rating*  $C = 3,800 \text{ kN}$ ) are used.

Due to the danger of slippage bearings of the series 239 with a low *load rating* should be selected.

The bearings are produced with a reduced radial run-out (specification T52BW), since running inaccuracy of the rotating roll shell influences the quality of the paper web.

## Machine tolerances

Bearing seats on the axle according to f6 due to *point load* for the inner rings.

The outer rings have *circumferential load* and a tight fit; the bearing seats in the housings are machined to P6.

## Lubrication

When dynamic misalignment and/or slippage may occur, a very good lubrication system must always provide a load-carrying lubricating film. The bearings are supplied with the *lubricating oil* used for the hydraulic system (ISO VG 150 with *EP additives*). The oil is fed laterally to the bearings via holes. In new designs and particularly with heated rolls, the *lubricating oil* is fed via lubricating holes in the inner ring directly to the bearing contact areas.

The deep groove ball bearings of the transmission arranged at the *locating bearing* side are supplied with *oil* via a separate oil circuit.

## Sealing

The bearings are *sealed* externally with a shaft seal. To the roll side a baffle plate provides for an *oil* reservoir in the bearing area.

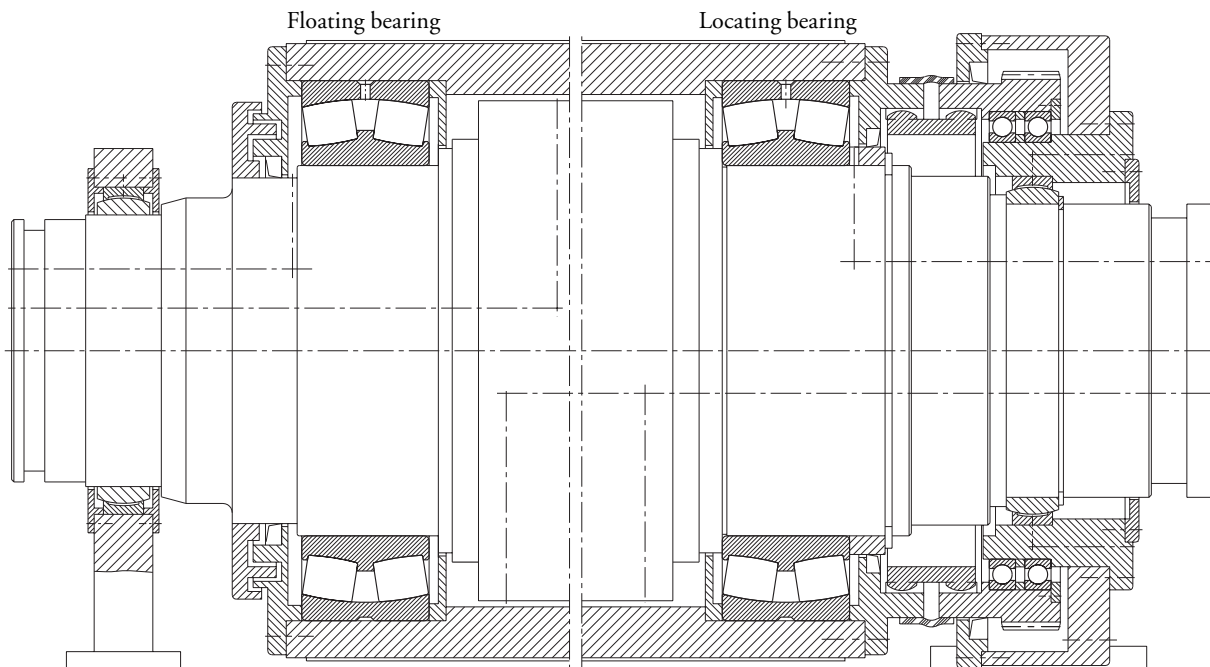

71: Anti-deflection roll bearings

# 72 Spreader rolls

Paper webs transported in lengthwise direction tend to creasing. Spreader rolls stretch or expand in cross direction the webs running over them. They flatten creases and any middle or end parts of the web which are loose. Spreader rolls consist of a stationary axle which is bent symmetric to its longitudinal axis, and around which the roll shell rotates. Tube-shaped sections make up the roll shell and are arranged to rotate freely and have angular freedom. The sections adjust to one another in such a way that the bending form of the axle is reflected on the shell surface. Depending on the case of application – wet end section, dryer section, or subsequent processing – the sections are made of stainless steel or provided with a flexible coating (e.g. rubber).

## Operating data

Roll length 8,300 mm, consisting of 22 sections; weight/section plus wire or paper web pull at 30° wrap angle 2 kN/m; a radial load of just 0.5 kN per bearing results therefrom.

Rotation of roll shell 1,160 min<sup>-1</sup>.

Operating temperature in the wet end section 40 °C; in the dryer section and in subsequent processing with infrared drying temperatures can reach 120 °C.

## Bearing selection, dimensioning

With rotating outer ring, extremely smooth running is required from the bearings since the sections in the wet end section and in the dryer section or subsequent processing are only driven by the wire tension and the paper web respectively.

High operational reliability is also necessary since the failure of one bearing alone means that the whole spreader roll has to be dismantled.

FAG 61936.C3 deep groove ball bearings are selected. The increased *radial clearance* C3 permits easy adjustment of the sections. With the low load, the bearings have a *nominal life* L<sub>h</sub> of well over 100,000 hours.

## Machining tolerances

As the outer ring of the bearing rotates with the roll shell it is given a tight *fit* with M6 tolerance and is secured axially by a snap ring.

The inner ring has *point load* and is fitted to the shaft sleeve with h6. Due to the bent roll axle and for assembly reasons the sleeve is loosely fitted and axially attached with a screw.

## Lubrication

The bearings are greased for life, i.e. no relubrication is provided for. The selection and filling quantity of *lubricating grease* is determined by the demand for smooth running as well as a *service life* of up to five years (8,000 operating hours per year). Low-friction *greases* (e.g. greases of class LG10 for the wet end section) are advantageous with high speeds and low loads.

## Sealing

Non-rubbing dust shields are used for *sealing* due to the smooth running required. They are stuck to the bearing outer ring on both sides so the *base oil* centrifuged from the *lubricating grease* cannot escape. Round cord seals also provide for oil tightness.

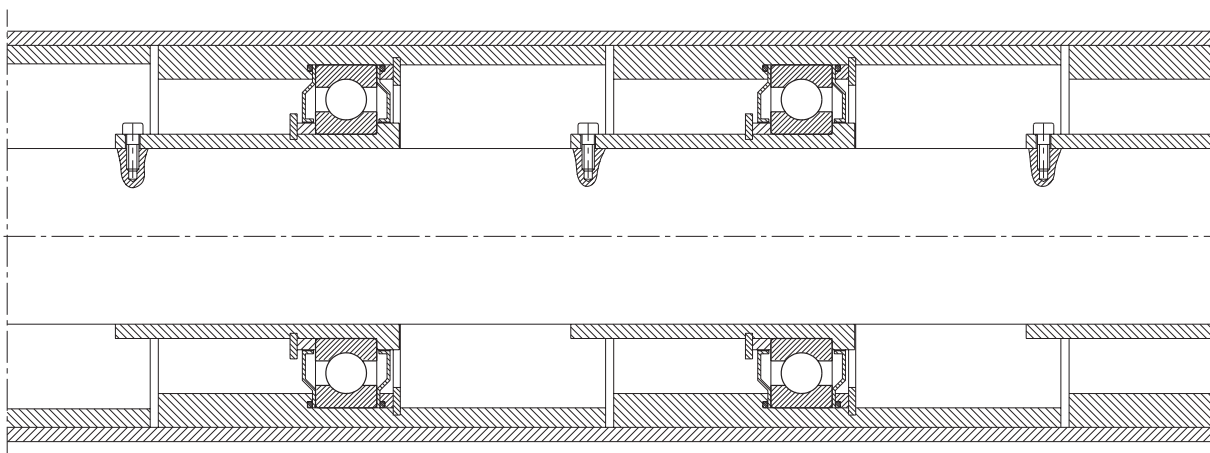

72 Spreader roll bearings

# 73 Run wheel of a material ropeway

## Operating data

Speed  $n = 270 \text{ min}^{-1}$ ; radial load  $F_r = 8 \text{ kN}$ . Thrust loads as guidance loads only, considered by 20 % of the radial load:  $K_a = 1.6 \text{ kN}$ .

## Bearing selection

Each run wheel is supported by two tapered roller bearings FAG 30306A. The bearings are assembled in *O arrangement* which provides for a wider bearing spread than an *X arrangement*. The wider the spread, the lower the additional bearing load from thrust load  $K_a$ .

## Bearing dimensioning

As thrust load  $K_a$  acts at the wheel circumference, it generates radial reaction forces at the bearing locations.

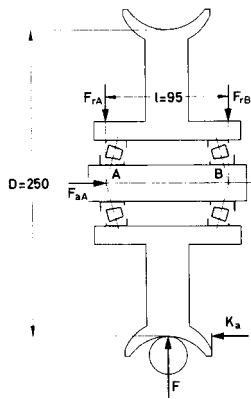

Bearing A:

$$F_{rA} = F_r/2 + K_a \cdot (D/2)/l = 4 + 1.6 \cdot 125/95 = 6.1 \text{ kN}$$

The thrust load  $K_a = 1.6 \text{ kN}$  acts toward bearing A.

Bearing B:

$$F_{rB} = F_r/2 - K_a \cdot (D/2)/l = 4 - 1.6 \cdot 125/95 = 1.9 \text{ kN}$$

Radial loads acting on a shaft supported on two tapered roller bearings generate axial reaction loads which have to be considered in the calculation of the *equivalent dynamic load*. These internal loads together with the external thrust loads should, therefore, be taken into account for *life* calculation (see FAG catalogue WL 41 520, chapter "Tapered roller bearings").

Data for tapered roller bearings FAG 30306A (designation to DIN ISO 355: T2FB030):

*dynamic load rating*  $C = 60 \text{ kN}$ ,  
Thrust factor  $Y = Y_A = Y_B = 1.9$ .

Thus,

$$F_{rA}/Y = 6.1/1.9 = 3.2; F_{rB}/Y = 1.9/1.9 = 1 \text{ and consequently } F_{rA}/Y > F_{rB}/Y$$

The second condition proven is

$$K_a > 0.5 \cdot (F_{rA}/Y - F_{rB}/Y) = 0.5 (3.2 - 1) = 1.1$$

For calculation of bearing A the following thrust load  $F_{aA}$  must, therefore, be taken into account:

$$F_{aA} = K_a + 0.5 \cdot F_{rA}/Y = 1.6 + 0.5 \cdot 1.9/1.9 = 2.1 \text{ kN}$$

Consequently, the *equivalent dynamic load*  $P_A$  of bearing A is:

$$P_A = 0.4 \cdot F_{rA} + Y F_a = 0.4 \cdot 6.1 + 1.9 \cdot 2.1 = 6.45 \text{ kN}$$

With this load, the indicated *dynamic load rating* and the *speed factor*  $f_n = 0.534$  ( $n = 270 \text{ min}^{-1}$ ) the *index of dynamic stressing*.

$$f_L = C/P_A \cdot f_n = 60/6.45 \cdot 0.534 = 4.97$$

This value corresponds to a *nominal rating life* of more than 100,000 hours. Since this calculation is based on the most unfavourable load conditions, the thrust load acting constantly at its maximum and only in one direction, the bearing is adequately dimensioned with regard to *fatigue life*. The *service life* will probably be terminated by *wear*, especially under adverse operating conditions (high humidity, heavy contamination). The load carrying capacity of bearing B does not need to be checked since its loading is much less than that of bearing A.

## Machining tolerances

The run wheel mounting is a so-called hub mounting, i.e. the run wheel, with the two cups, rotates about a stationary shaft. The cups carry *circumferential load* and are thus tight-fitted. The shaft is machined to h6, the hub bore to M6.

## Lubrication, sealing

The bearings and the free spaces have to be filled during mounting with *grease*, e. g. FAG rolling bearing grease *Arcanol* L186V. The grease filling will last for approximately one year.

In the example shown, the bearings are sealed by spring steel seals (Nilos rings).

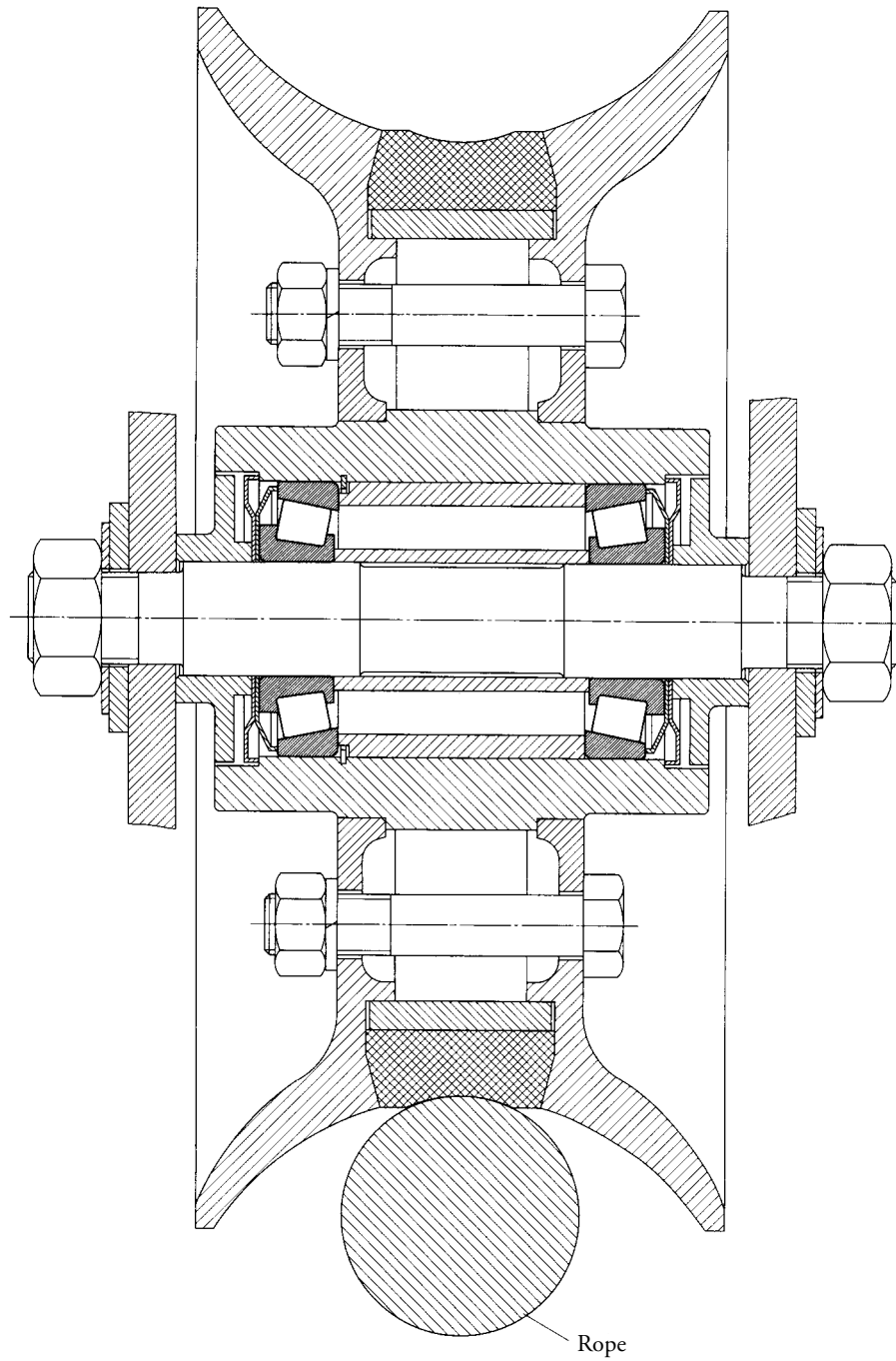

73: Run wheel of a material ropeway

---

# 74 Rope return sheaves of a passenger ropeway

---

In this example of a passenger ropeway, eight sheaves are installed at the mountain station and another eight at the valley station including the sheaves in the valley station tensioning weight pit. The sheave diameters are 2.8 and 3.3 meters.

## Bearing selection, dimensioning

The valley station sheaves and the tensioning weight sheaves are fitted with spherical roller bearings FAG 22234E. The sheaves at the mountain station are supported by spherical roller bearings FAG 22240B.MB.

The load on the bearings FAG 22234E installed in the tensioning weight sheaves is  $P = 65$  kN each; with a *dynamic load rating*  $C = 1,100$  kN and a *speed factor*  $f_n = 0.838$ , corresponding to a speed of  $60 \text{ min}^{-1}$ , the *index of dynamic stressing*:

$$f_L = C/P \cdot f_n = 1,100/65 \cdot 0.838 = 14.2.$$

This shows that the bearings are more than adequately dimensioned with regard to *fatigue life*.

The one-piece sleeve carrying the bearings allows convenient changing of the rope sheaves.

## Machining tolerances

The outer rings carry *circumferential load* and require, therefore, a *tight fit*. To safeguard the spherical roller bearings against detrimental axial preloading, the design is of the *floating mounting* type. The outer rings are securely locked via the two covers by means of a spacer ring. The centre lip of sleeve H is slightly narrower than the spacer so that the sheave can float axially on the sleeve via the loosely fitted inner rings. The sleeve is locked to prevent it from rotating with the inner rings.

Sleeve to g6; hub bore to M6;

The sleeve has a sliding *fit* on the shaft.

## Lubrication, sealing

*Grease lubrication* with FAG rolling bearing grease *Arcanol* L186V. Relubrication by means of lubricating holes in the shaft.

A shaft *seal* ring in the covers provides adequate protection against contamination.

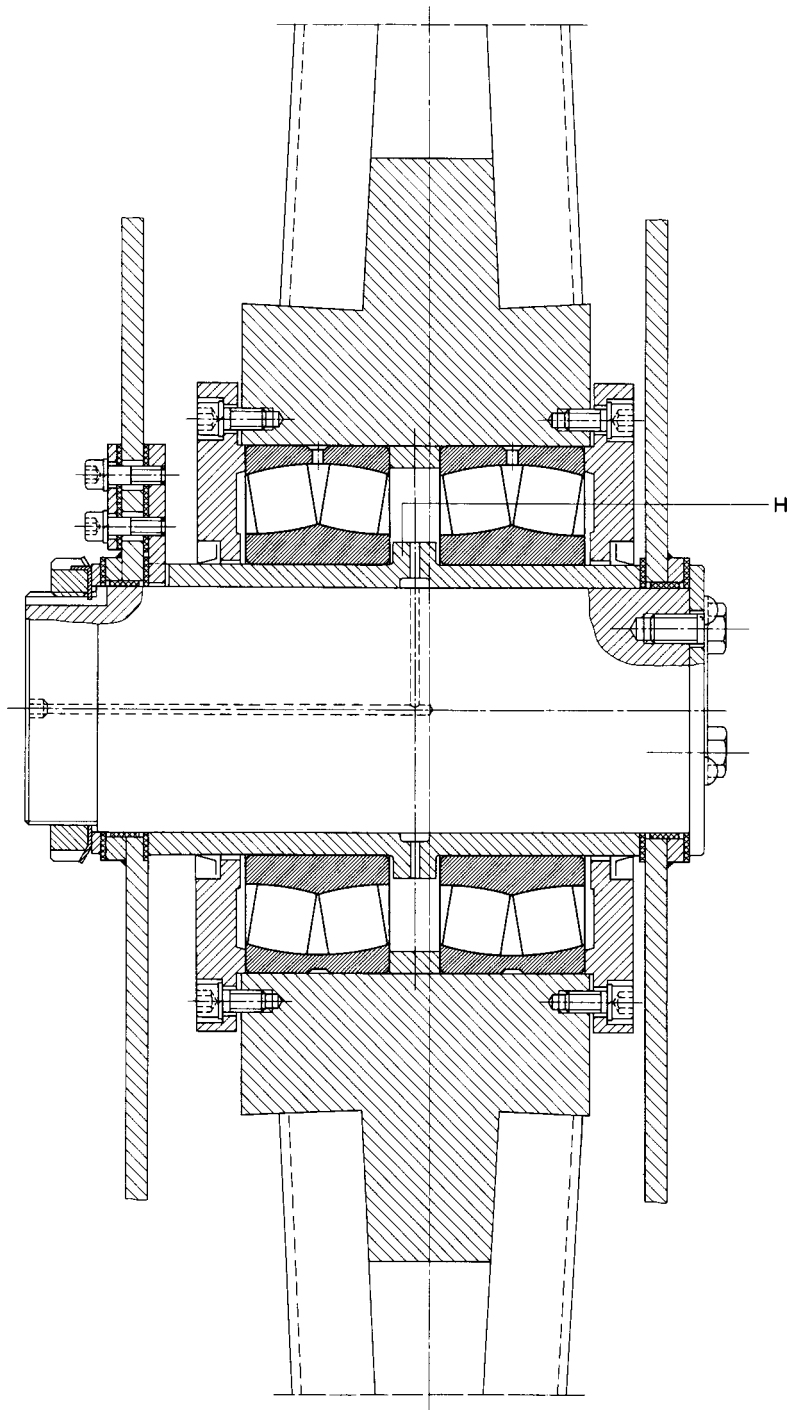

74: Rope return sheaves of a passenger ropeway

# 75 Rope sheave (underground mining)

These sheaves are arranged in the head frames of the pits. The rope fastened to the cage runs from the drive sheave or the drum of the hoist into the mine by passing over the rope sheaves.

## Operating data

Static rope load 452 kN; weight of rope sheave and shaft 75 kN; rope sheave diameter  $d_s = 6.3$  m; haulage speed  $v = 20$  m/s; wrap angle  $140^\circ$ .

Acceleration forces are taken into account by assuming 10 % of the static rope load.

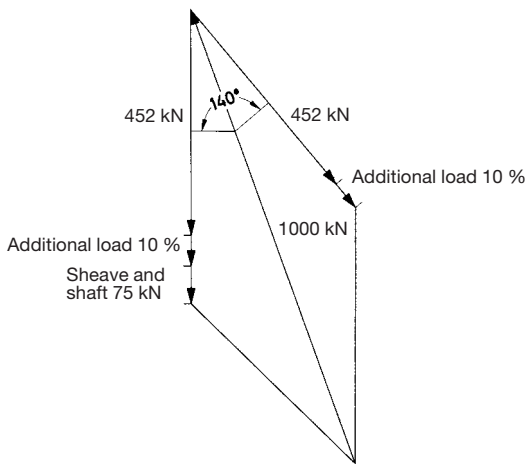

## Bearing selection, dimensioning

From the parallelogram of forces the resultant load is approximately 1,000 kN. Since the two bearings are symmetrically arranged, the radial load per bearing is  $P = 500$  kN.

Speed  $n = v \cdot 60 / (d_s \cdot \pi) = 20 \cdot 60 / (6.3 \cdot 3.14) = 60 \text{ min}^{-1}$ ; this yields a *speed factor*  $f_n = 0.838$ .

The recommended *index of dynamic stressing*  $f_L$  is 4...4.5. With 4.5, the *nominal rating life* is about 75,000 hours. It should be borne in mind that only in rare cases the rope sheave bearings fail due to material fatigue; usually their *service life* is terminated by *wear*.

Thus, the required *dynamic load rating*  $C$  for the spherical roller bearing is calculated as follows:

$$C = f_L / f_n \cdot P = 4.5 / 0.838 \cdot 500 = 2,680 \text{ kN}$$

Spherical roller bearings FAG 23252BK.MB with a *dynamic load rating*  $C = 2,900$  kN were chosen.

The bearings feature a high load carrying capacity and compensate for potential housing misalignments, shaft deflections and deformations of the head frame.

## Machining tolerances

One bearing acts as the *locating bearing*, the other one as the *floating bearing*. Both bearings have a tapered bore (K 1:12). They are mounted on the shaft journal with withdrawal sleeves (FAG AH2352H). Mounting and dismantling is simplified by using the hydraulic method. For this purpose the withdrawal sleeves feature oil grooves and ducts. The spherical roller bearings are supported by FAG plummer block housings FS3252AHF and FS3252AHL.

Shaft journal to h6, cylindricity tolerance IT5/2 (DIN ISO 1101).

Housing to H7.

## Lubrication, sealing

*Grease lubrication* with FAG rolling bearing grease *Arcanol L186V*.

A multiple labyrinth protects the bearings against contamination. Replenishment of labyrinth *grease* is effected about every 4...6 weeks.

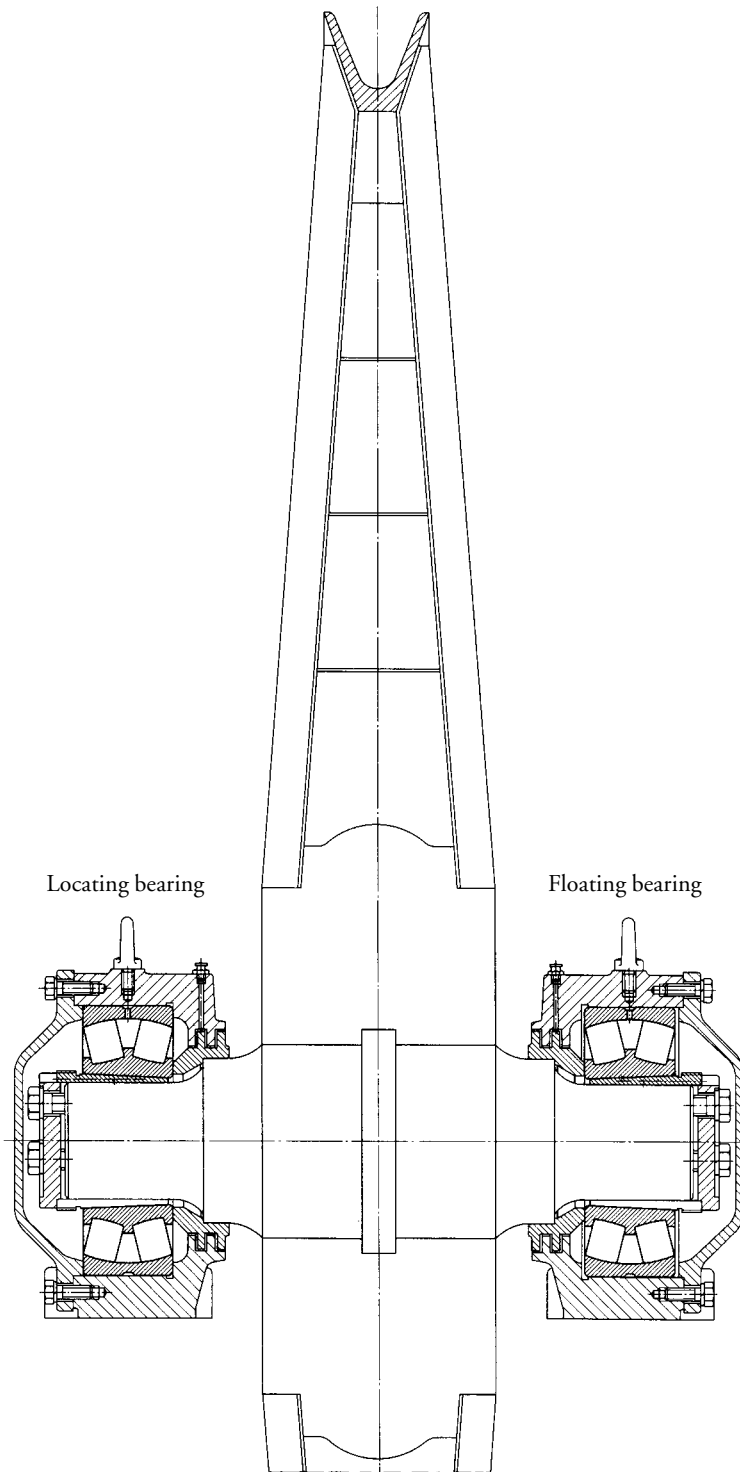

75: Rope sheave (underground mining)

# 76 Rope sheave of a pulley block

In pulley blocks it is customary to arrange several sheaves on a common shaft. To achieve minimum overall pulley block width, the sheaves and their bearings should, therefore, be as compact as possible.

## Bearing selection

For the rope sheaves of pulley blocks the wrap angle is  $180^\circ$ . Thus the radial load on the bearing is twice the rope pull. Thrust loads, resulting from a possible inclined rope pull, and the moments caused by them are low and can be neglected for *bearing life* calculation. Adequate bearing *spread* for load accommodation is achieved by mounting either two bearings or one double-row bearing. Deep groove ball bearings are satisfactory for accommodating the loads in this application.

The bearings are mounted on a sleeve, forming a ready-to-mount unit with the sheave which can be easily replaced.

## Operating data and bearing dimensioning

Rope pull $S$	40 kN
Bearing load $F = 2 \cdot S$	80 kN
Speed $n$	$30 \text{ min}^{-1}$
Speed factor $f_n$	1.04
Bearings mounted	2 deep groove ball bearings FAG 6220
Dynamic load rating	$C = 2 \times 122 \text{ kN}$
Equivalent dynamic load	$P = F/2 = 40 \text{ kN}$
Index of dynamic stressing	$f_L = C/P \cdot f_n$ $= 122/40 \cdot 1.04 = 3.17$
Nominal rating life	$L_h = 16,000 \text{ h}$

Usually, an *index of dynamic stressing*  $f_L = 2.5 \dots 3.5$  is used for rope sheaves. This corresponds to a *nominal rating life* of 8,000 to 20,000 hours.

Thus the bearings are adequately dimensioned compared with established field applications.

## Machining tolerances

The mounting is a so-called hub mounting, i.e. the pulley, with the outer rings, rotates about a stationary shaft. The outer rings carry *circumferential load* and are press-fitted: hub to M7.

The inner rings carry *point load* allowing a loose *fit* or sliding fit: shaft sleeve to g6 or h6.

## Lubrication, sealing

The sheave bearings are lubricated with lithium soap base *grease* of *penetration* class 3 (*Arcanol L71V*). High loads (load ratio  $P/C > 0.15$ ) require a lithium soap base *grease* of *penetration* class 2 and *EP-additives* (*Arcanol L186V*). One *grease* filling normally lasts for several years.

The rope sheave in this example is sealed by spring steel *seals* (Nilos rings).

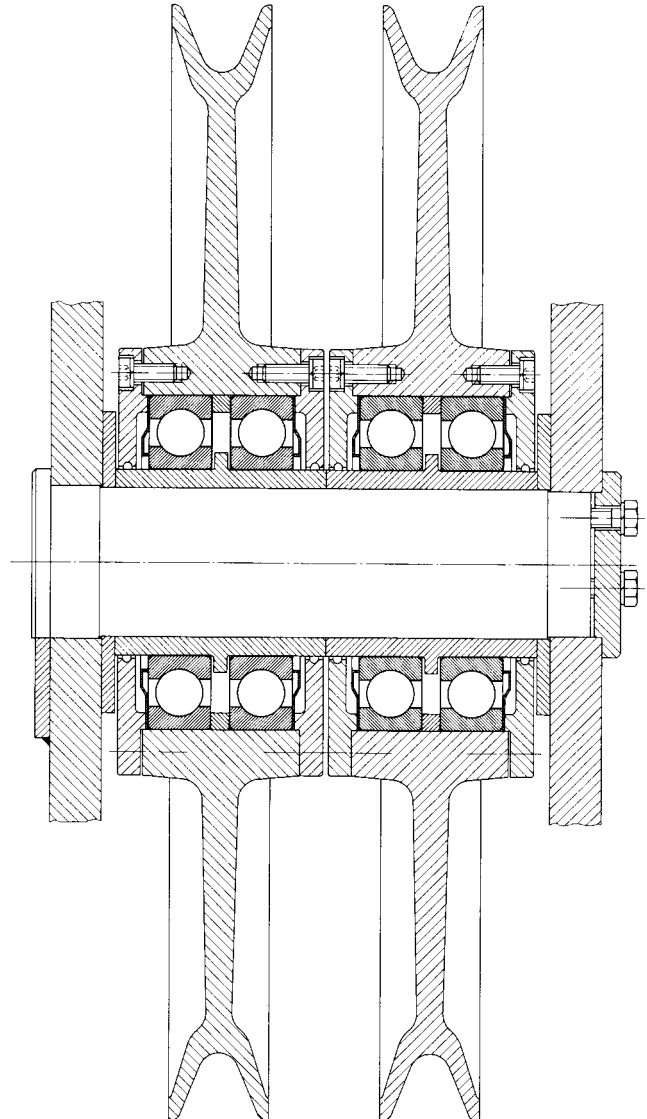

76: Rope pulleys with deep groove ball bearings

---

# 77–78 Gantry of a floating crane

---

Floating cranes are used in harbours for transportation of heavy and bulky goods, in shipyards for repair work and for ship outfitting. Due to their mobility they are an ideal complement to stationary cranes.

The pillar of the crane described is attached to the ship. The slewing gantry with the crane superstructure is supported on the crane pillar. The bearing mounting has to take up the weight of the superstructure and the payload. Since the common centre of gravity of payload and gantry is outside the pillar axis, a tilting moment is produced causing horizontal reaction forces in the bearings at the upper and lower pillar end.

At the upper pillar end the gantry runs on the so-called pillar bearing mounting. It consists either of one single spherical roller thrust bearing or one spherical roller bearing combined with one spherical roller thrust bearing, depending on the amount of radial loading.

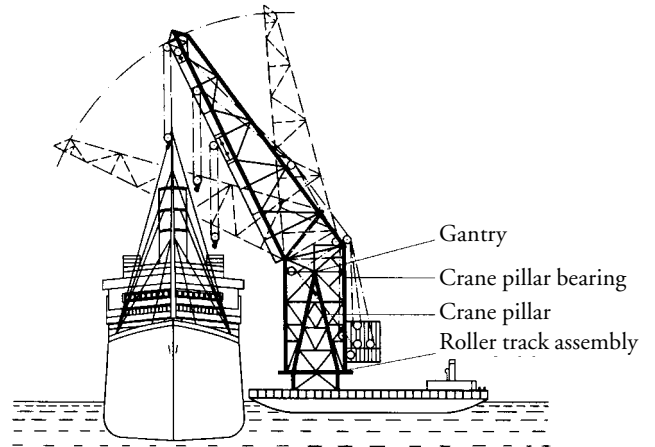

At the pillar foot the gantry is supported on a roller-track assembly (see example no. 79).

# 77 Crane pillar mounting with a spherical roller thrust bearing

## Operating data

Thrust load (crane superstructure and payload)  $F_a = 6,200$  kN; radial load (reaction forces resulting from tilting moment and wind pressure)  $F_r = 2,800$  kN; speed  $n = 1 \text{ min}^{-1}$ .

## Bearing selection, dimensioning

The thrust load, consisting of the weight of the slewing superstructure and the payload, is much higher than the radial load resulting from the tilting moment and wind pressure. Therefore, the crane pillar bearing must have a high thrust load carrying capacity. Moreover, the bearing must be *self-aligning* to compensate for misalignment and elastic deformation unavoidable on these crane structures. Due to the low speed of  $1 \text{ min}^{-1}$  the bearing is chosen with regard to its static load carrying capacity.

A spherical roller thrust bearing FAG 294/630E.MB with a *static load rating* of  $C_0 = 58,500$  kN; factor  $X_0 = 2.7$  is selected.

For spherical roller thrust bearings under *combined load* the ratio  $F_r/F_a$  must be small in order to ensure that most of the rollers transmit loads. Condition:  $F_r/F_a \leq 0.55$ .

In this example

$$F_r/F_a = 2,800/6,200 = 0.45$$

Thus the *equivalent static load*

$$\begin{aligned} P_0 &= F_a + X_0 \cdot F_r = F_a + 2.7 \cdot F_r \\ &= 6,200 + 2.7 \cdot 2,800 = 13,800 \text{ kN} \end{aligned}$$

The *index of static stressing*

$$f_s = C_0/P_0 = 58,500/13,800 = 4.24$$

Thus, the requirement  $f_s \geq 4$  for spherical roller thrust bearings (FAG catalogue WL 41 520) whose housing and shaft washers – as in this example – are fully supported is met.

With  $f_s$  values  $\geq 4 \dots \leq 6$  the shaft washer and the housing washer must be fully supported axially, and good radial support of the housing washer must also be provided.

## Machining tolerances

Shaft washer to j6; housing washer to K7

## Lubrication, sealing

*Oil* bath lubrication, with the rollers fully immersed in *oil*. The *oil* level should be maintained to the upper edge of the shaft washer and is controlled by means of an *oil* level indicator.

Due to adverse ambient conditions existing for floating crane applications, high-efficiency *seals* must be provided (*oil*-filled labyrinths). The inner and the outer labyrinth are interconnected by oil holes. The *oil* level in the labyrinths is also checked with an *oil* level indicator.

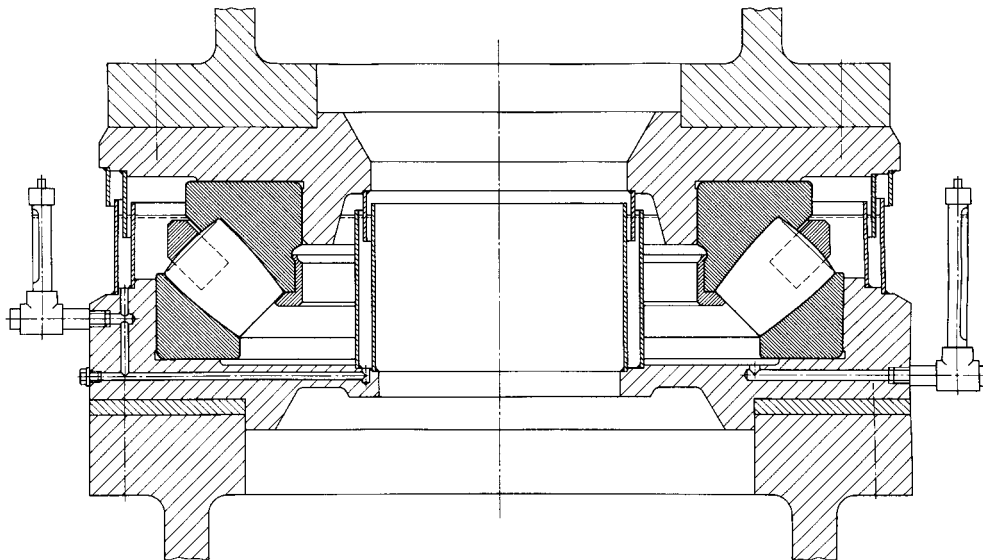

77: Crane pillar mounting with a spherical roller thrust bearing

# 78 Crane pillar mounting with a spherical roller thrust bearing and a spherical roller bearing

## Operating data

Thrust load (crane superstructure and payload)  $F_a = 1,700$  kN; radial load (reaction forces resulting from tilting moment and wind pressure)  $F_r = 1,070$  kN; speed  $n = 1 \text{ min}^{-1}$ .

## Bearing selection, dimensioning

In this case  $F_r/F_a > 0.55$ . The radial load is relatively high. Therefore, it is accommodated by an additional radial bearing, a spherical roller bearing. The two bearings are mounted so that their pivoting centres coincide. Thus angular alignability is ensured. A thrust washer inserted between the two bearings prevents excessive radial loading on the *thrust bearing*. The spherical roller bearing size depends on that of the spherical roller thrust bearing. The outside diameter of the *radial bearing* must be larger than the housing washer of the *thrust bearing*. To ensure close guidance of the crane superstructure, the reduced *radial clearance* C2 is provided for the *radial bearing*.

Crane pillar mountings with one spherical roller bearing and one spherical roller thrust bearing provide compact designs. They require, however, a wider mounting space than mountings with one single spherical roller thrust bearing.

The mounting features a spherical roller thrust bearing FAG 29440E with the *static load rating*  $C_0 = 8,500$  kN and a spherical roller bearing FAG 23056B.MB.C2 with the *static load rating*  $C_0 = 3,000$  kN.

For calculating the *equivalent static load* for the spherical roller thrust bearing it is assumed that the friction at the thrust washer, acting as a radial load, is 150 kN. Thus  $F_r/F_a < 0.55$  for the spherical roller thrust bearing.

## Equivalent static load:

$$P_0 = F_a + X_0 \cdot F_r = F_a + 2.7 \cdot F_r \quad \text{for } F_r \leq 0.55 F_a \\ = 1,700 + 2.7 \cdot 150 = 2,100 \text{ kN}$$

For the spherical roller bearing:

$$P_0 = F_r = 1,070 \text{ kN}$$

Hence the *indices of static stressing*  $f_s = C_0 / P_0$  are:

$$\text{Spherical roller thrust bearing} = 8,500 / 2,100 = 4.05$$

$$\text{Spherical roller bearing} = 3,000 / 1,070 = 2.8$$

These values show that the bearings are safely dimensioned.

The shaft washer and housing washer of spherical roller thrust bearings with  $f_s$  values of  $\geq 4 \dots \leq 6$  must be fully supported axially; good radial support of the housing washer is also required.

## Machining tolerances

Spherical roller thrust bearing:

Shaft washer to j6,

housing washer to K7

Spherical roller bearing:

shaft to j6; housing to J7

## Lubrication, sealing

The bearing housing is filled with *oil* beyond the upper edge of the spherical roller bearing, i.e. the bearings run in an oil bath. Thus they are well protected against condensation water and corrosion.

Outer *sealing* is provided by labyrinths. In view of the adverse ambient conditions an additional, rubbing *seal* with elastic lip is provided. Inner sealing is effected by the tube communicating with the housing, and a labyrinth.

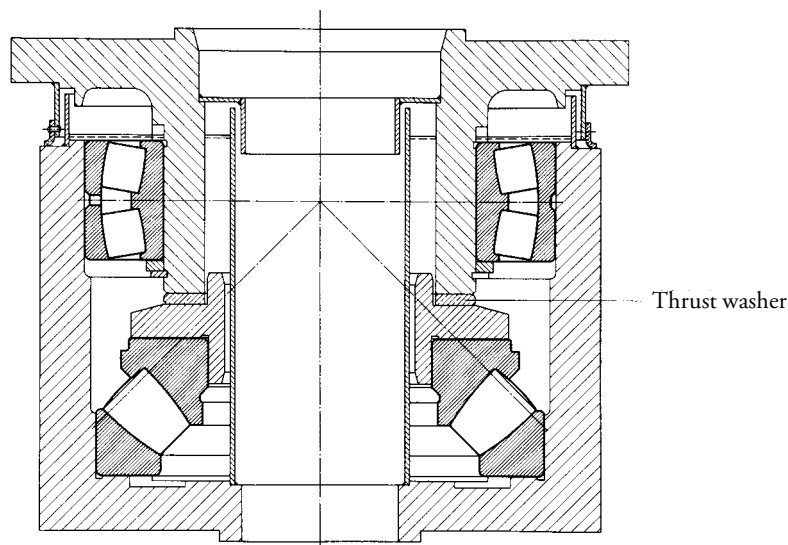

78: Crane pillar mounting with a spherical roller thrust bearing and a spherical roller bearing

# 79 Roller track assembly

The radial bearing mounting at the pillar foot consists normally of several rollers travelling on a circular track. Each of these rollers is supported by two bearings, the upper bearing being the *locating bearing*, the lower one the *floating bearing*.

## Operating data

The maximum load on one roller is 2,200 kN. Thus, each bearing is loaded with  $P_0 = 1,100$  kN.

## Bearing selection, dimensioning

The rollers transmit only the horizontal loads resulting from the tilting moment. To cater for the misalignment conditions inherent in structural steelwork and for wheel axle deflection, *self-aligning bearings* have to be provided.

Spherical roller bearings FAG 23230ES.TVPB with *static load rating*  $C_0 = 1,630$  kN are mounted. With an *equivalent static load*  $P_0 = 1,100$  kN an *index of static stressing*

$$f_s = C_0/P_0 = 1,630 / 1,100 = 1.48$$

is calculated.

This value meets the requirements for smooth running of the bearing.

## Machining tolerances

The inner rings carry *circumferential load* and are fitted tightly.

Shaft to k6; housing to H7.

## Lubrication, sealing

The bearings and housing cavities are packed to capacity with a lithium soap base *grease* with *EP additives* (FAG rolling bearing grease *Arcanol* L186V). Relubrication is possible through lubricating nipples in the housing cover.

Outer *sealing* is provided by the housing cover, inner sealing by a shaft seal ring. A flinger ring between roller and lower bearing additionally protects the lower shaft seal ring against dirt and rubbed-off particles.

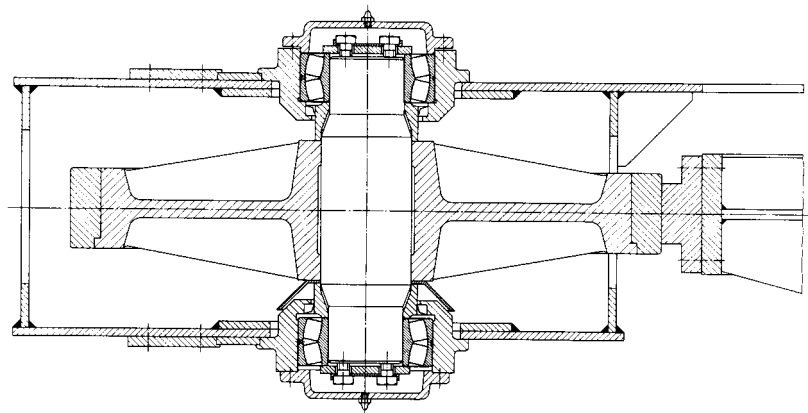

---

## Crane run wheels

---

Bearings in crane run wheels have to accommodate the heavy loads resulting from the deadweight of the crane and the payload, and axial and radial reaction loads

resulting from the axial guiding loads between wheel flange and rail.

# 80 Crane run wheel

## Operating data

Wheel load  $R = 180 \text{ kN}$ ; operating speed  $n = 50 \text{ min}^{-1}$ ; wheel diameter  $d_1 = 630 \text{ mm}$ ; bearing centres  $l = 186 \text{ mm}$ .

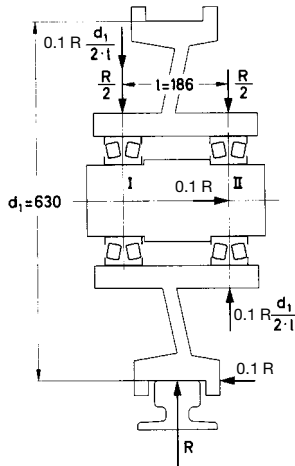

## Bearing selection

The bearings fitted in run wheels are often designed as hub mountings. The run wheel rotates, together with the bearing outer rings, about a stationary shaft. Spherical roller bearings are used because of their very high load carrying capacity.

The bearings fitted are two spherical roller bearings FAG 22220E. The distance between the two bearings should not be too small in order to keep the bearing reaction loads resulting from the wheel-rail contact within reasonable limits.

This bearing arrangement is standardized by DIN 15 071. The two spherical roller bearings run on a sleeve to allow for rapid replacement of the complete run wheel unit. It is a *floating bearing arrangement*, the inner rings being displaceable on the sleeve. Depending on the thrust load direction, either the left-hand or the right-hand bearing abuts the sleeve collar. This arrangement allows optimum bearing loading, since the bearing which accommodates the additional thrust loads is relieved of radial load due to the tilting moment from the thrust load.

## Bearing dimensioning

The weight of the crane and the maximum payload are known. The thrust acting between wheel and rail can, however, only be estimated. The *equivalent dynamic load*  $P$  acting on the bearings is calculated in accordance with DIN 15 071; this standard specifies the thrust resulting from friction between wheel and rail to be 10 % of the radial load. The bearing loads  $P_I$  (bearing I) and  $P_{II}$  (bearing II) are:

$$P_I = X \cdot [R/2 + 0.1 \cdot R \cdot d_1 / (2 \cdot l)]$$

$$P_{II} = X \cdot [R/2 - 0.1 \cdot R \cdot d_1 / (2 \cdot l)] + Y \cdot 0.1 \cdot R$$

With the radial factor  $X = 1$  and  $e = 0.24$  for  $F_a/F_r \leq e$  the thrust factor  $Y = 2.84$ .

$$\text{Thus } P_I = 90 + 18 \cdot 630/372 = 120.5 \text{ kN} = P_{\max}$$

$$P_{II} = 90 - 30.5 + 2.84 \cdot 18 = 110.6 \text{ kN} = P_{\min}$$

Assuming that the bearing loads vary linearly between  $P_{\min}$  and  $P_{\max}$ ,

$$P = (P_{\min} + 2 \cdot P_{\max})/3 = (110.6 + 241)/3 = 117.2 \text{ kN}$$

With the *dynamic load rating*  $C = 360 \text{ kN}$  and the *speed factor*  $f_n = 0.885$  ( $n = 50 \text{ min}^{-1}$ ) the *index of dynamic stressing*

$$f_L = C/P \cdot f_n = 360/117.2 \cdot 0.885 = 2.72$$

With the generally recommended value for crane run wheels  $f_L = 2.5 \dots 3.5$ , the bearing mounting is adequately dimensioned.

## Machining tolerances

The bearing outer rings, which carry *circumferential load*, are tight *fits*. The hub is machined to M7, the sleeve to g6, thus providing for a slide *fit* for the inner rings. This prevents detrimental axial preloading and simplifies bearing mounting and dismantling.

## Lubrication, sealing

The bearings are lubricated with a lithium soap base grease with *EP additives* (FAG rolling bearing grease Arcanol L186V). The *relubrication interval* is approximately one year.

Gap-type *seals* or simple rubbing *seals* are in most cases satisfactory.

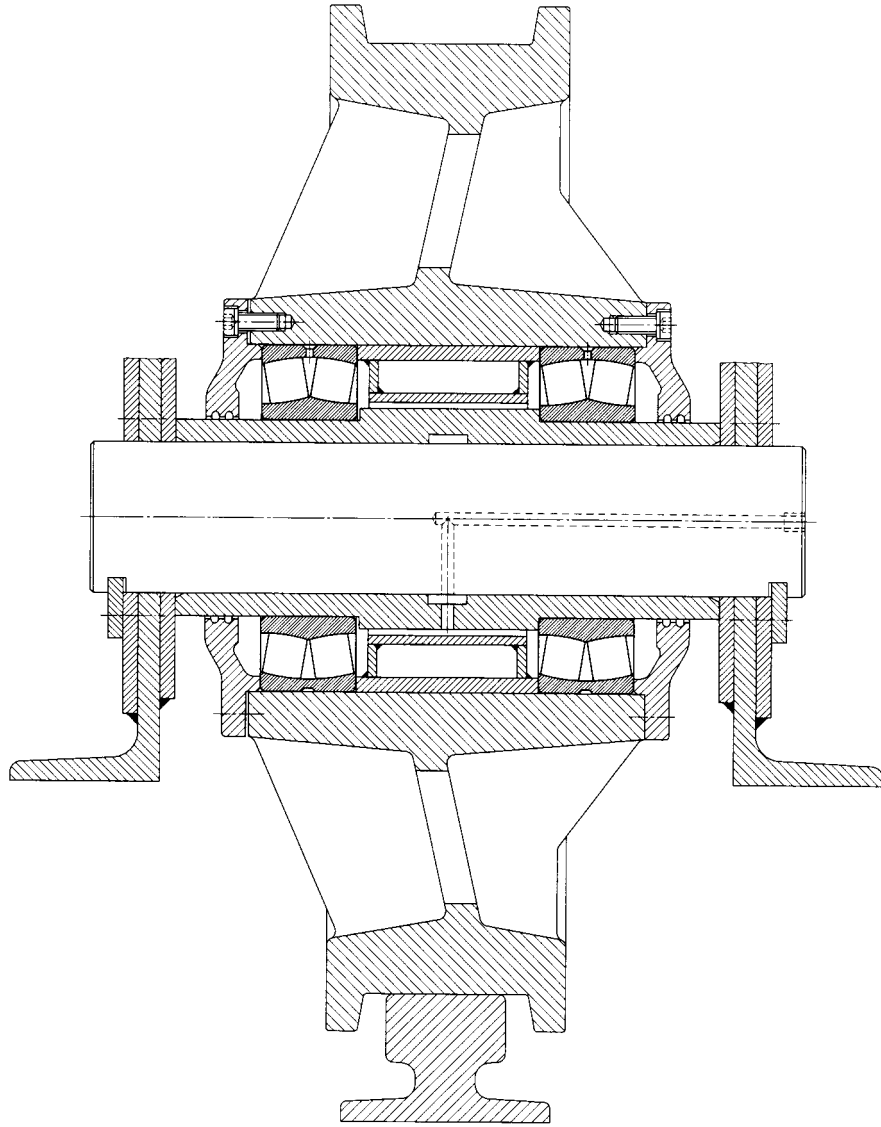

80: Crane run wheel with spherical roller bearings

# 81 Crane hook

The load suspended from a crane hook often has to be swivelled before being lowered. Therefore, the hooks of heavy-duty cranes are designed for these swivelling motions.

## Bearing selection, dimensioning

Since the weight of the payload acts vertically downward, the load is pure thrust. Therefore, loose radial guidance of the shaft in the crosshead is satisfactory.

The load carrying capacity of the bearing is based on its *static load rating*. A thrust ball bearing FAG 51152FP with a *static load rating*  $C_0 = 1,020$  kN is mounted. Based on the maximum hook load of 1,000 kN plus a safety margin of 10 %, the *index of static stressing*  $f_s = C_0/P_0 = 1,020 / 1,100 = 0.93$ ; i. e., permanent deformation occurs at maximum load. However, it is so small that it does not interfere with the swivelling of the load.

The bearing is *adjusted* against the collar at the hook shaft by means of a locknut. This prevents the shaft washer from separating when the crane hook is set on the ground.

## Machining tolerances

The bearing seats are machined to j6 (washer) and to H7 (housing).

## Lubrication, sealing

The bearing assembly is packed to capacity with lithium soap base *grease* with *EP additives* (FAG rolling bearing grease *Arcanol* L186V). Maintenance of the bearing is not required. Above the crane hook nut a sheet steel cap is provided which protects the bearing against contamination.

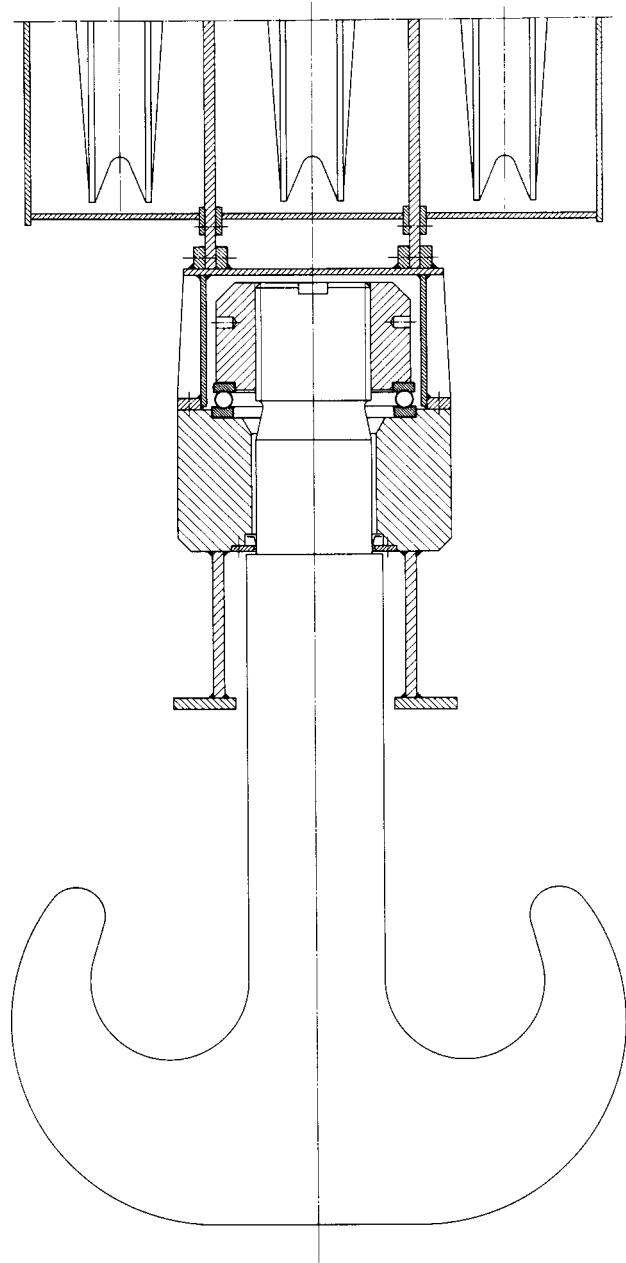

81: Crane hook mounting

# 82 Mast guidance bearings of a fork lift truck

The fork lift carriage must run smoothly in order to handle the live loads efficiently. This requirement is satisfied by mast guide rollers and chain return sheaves.

Mast guide rollers (HMFR) and chain sheaves (KR) of modern fork lift trucks are largely fitted with double-row angular contact ball bearings.

## Bearing selection, bearing design

### Mast guide rollers

FAG HMFR30x75x20.75 are preferably used for fork carrier and lifting frame. They can accommodate radial loads, thrust loads and the moments resulting from these. The mast guide rollers feature thick-walled outer rings and can, therefore, accommodate even high, shock-type loads.

The profile and dimensions of the outer ring are largely dictated by the standardized U-beam dimensions.

### Chain sheaves

Chain sheaves FAG KR30x75x28/27 are attached to the hydraulically actuated upper section of the mast and serve to deflect the pull chain.

Due to their relatively thick-walled outer ring, the bearings can accommodate high radial loads made up of the deadweight of the fork lift carriage, including fork and live load. The outer ring profile is dictated by the pull chain used; lateral guidance is provided by the two lips. The distance between the two ball rows, together with the *contact angle*, provides for a wide *spread* so that the return sheaves can also accommodate tilting forces and axial guiding forces.

Roller mounting is simple; they are simply placed on the pin; axial preloading by a screw is not required. Chain return sheaves are axially locked.

## Machining tolerances

The inner rings of der mast guide rollers and return sheaves carry *point load*, thus a loose *fit* is satisfactory. The pin is machined to j6.

## Lubrication, sealing

The bearings are lubricated for *life* with a lithium soap base *grease (EP additives)*.

*Sealing* is provided by single- or double-lip RSR *seals*.

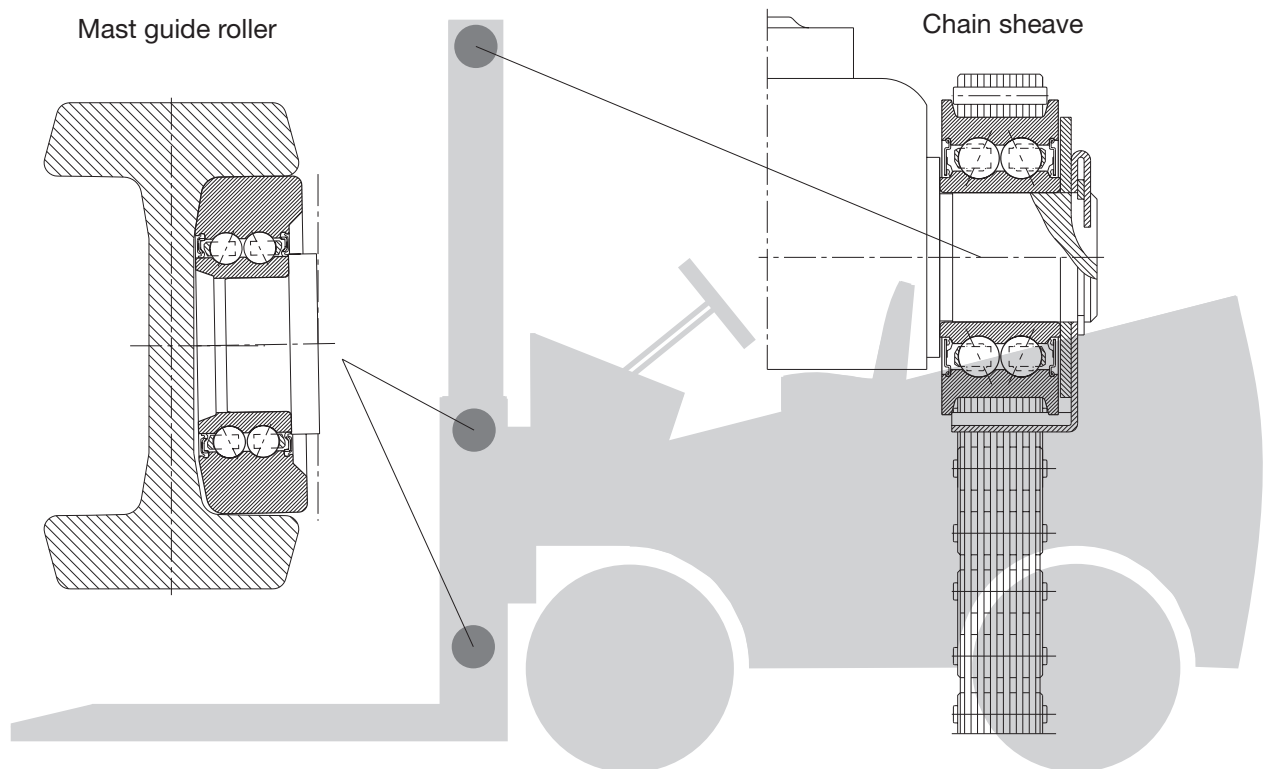

82: Mast guide roller and chain return sheave for a fork lift truck

# 83 Head pulley of a belt conveyor

One head pulley is not sufficient for very long belts, steeply inclined belts or heavily loaded belts. In such cases several head pulleys are mounted in tandem. In this application, two head pulleys are arranged at the drive station. Three identical driving motors are used: the first pulley is driven from both ends, the second one from one end only.

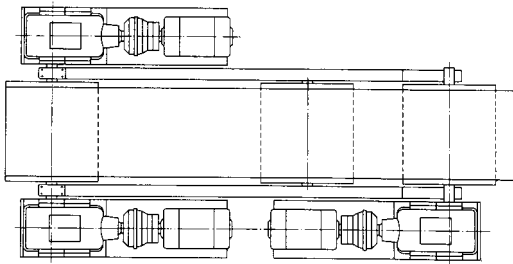

## Operating data

Power consumption 3 x 430 kW; belt width 2,300 mm; belt speed 5.2 m/s; conveying capacity 7,500 m<sup>3</sup>/h; pulley diameter 1,730 mm.

## Bearing selection, dimensioning

The shaft of the head pulley is supported on plummer blocks. The shaft diameter is dictated by strength considerations, thus determining the bearing bore and housing size. Spherical roller bearings FAG 23264K.MB are mounted. The one-piece plummer block housings FAG BND3264K are made of cast steel GS-45. One of the plummer blocks acts as the *locating bearing*, the other one as the *floating bearing*. To simplify mounting and dismounting hydraulic sleeves are used.

With an *index of dynamic stressing*  $f_L \approx 4$  the bearings are adequately dimensioned compared to field-proven bearing arrangements. Often the *bearing life* is limited by wear on *rolling elements* and raceways and is generally shorter than the *nominal rating life* (approx. 50,000 h), calculated with the *index of dynamic stressing*  $f_L$ . Improved cleanliness during mounting and operation, and a suitable lubricant, reduce *wear*, thus increasing the *bearing life*. These influences are taken into account in the *adjusted rating life calculation* by the *factor*  $a_{23}$ .

## Machining tolerances

The bearing inner rings carry *circumferential load*. They are fitted on the shaft with adapter sleeves FAG H3264HG. Shaft to h8 and cylindricity tolerance (DIN ISO 1101) IT5/2; housing bore to H7.

## Lubrication, sealing

*Grease* lubrication with a lithium soap base grease of *penetration* class 2 with *EP additives* (FAG rolling bearing grease *Arcanol* L135V or L186V).

The housing covers and rings on the shaft form non-rubbing labyrinth *seals*. These multiple labyrinths are filled with the same *grease* as the bearings and prevent penetration of foreign matter. In very dusty environments relubrication at short intervals is required.

*Grease* is injected into the bearing until some of the spent grease escapes from the labyrinths.

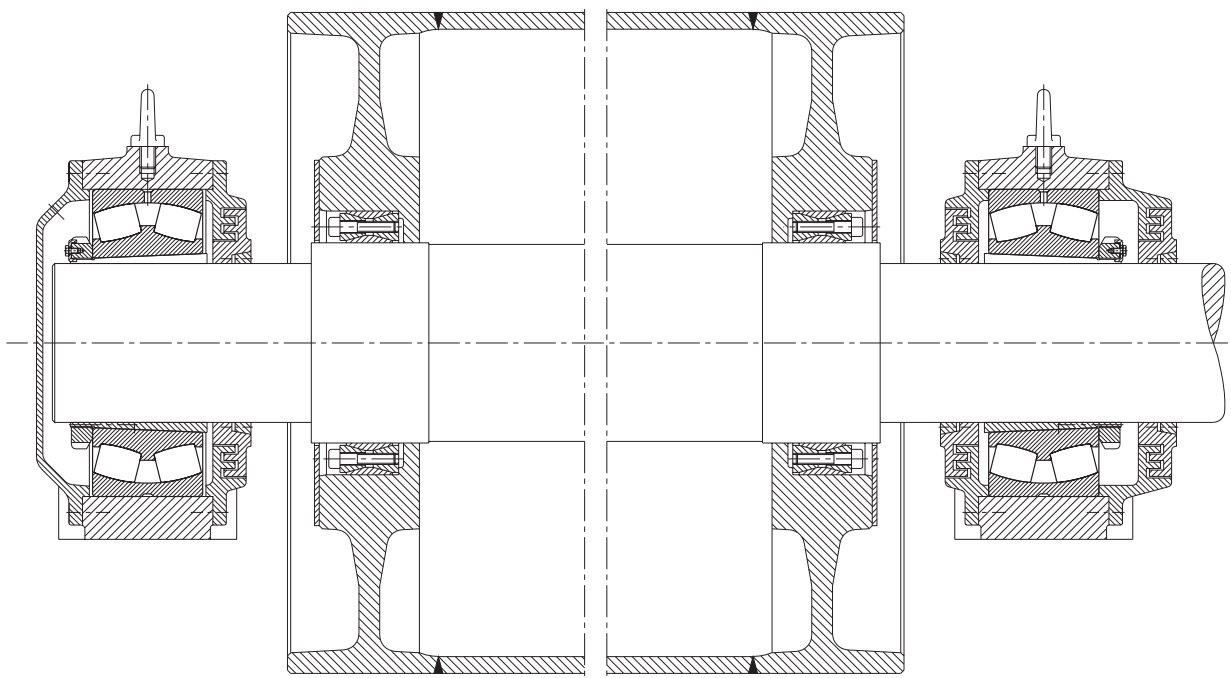

83: Head pulley bearing arrangement of a belt conveyor

# 84 Internal bearings for the tension/ take-up pulley of a belt conveyor

Non-driven pulleys in belt conveyors are frequently fitted with internal bearings. The bearings are integrated into the pulley so that the pulley body revolves about the stationary shaft.

## Operating data

Belt width 3,000 mm; belt speed 6 m/s; pulley diameter 1,000 mm; pulley load 1,650 kN.

## Bearing selection, dimensioning

These pulleys are supported either in two spherical roller bearings (fig. a) or in two cylindrical roller bearings (fig. b). The internal design of the cylindrical roller bearings allows the *rolling elements* to accommodate load-related shaft deflections without edge running.

In a spherical roller bearing arrangement, an FAG 23276BK.MB with an adapter sleeve FAG H3276HGJ is used as *locating bearing* and an FAG 23276B.MB is used as *floating bearing*.

In a cylindrical roller bearing arrangement, the *floating bearing* is an FAG 547400A and the *locating bearing* an FAG 544975A. Both cylindrical roller bearings have the main dimensions 360 x 680 x 240 mm and are interchangeable with spherical roller bearings FAG 23276BK.MB with an adapter sleeve FAG H3276HGJ.

The bearings must feature the required *dynamic load rating C*/the required bore diameter. With an *index of dynamic stressing*  $f_L > 4$ , the bearings are sufficiently dimensioned with regard to *fatigue life*.

Often, the actual *bearing life* is considerably shorter than the *nominal rating life* determined on the basis of the  $f_L$  value. The cause is *wear* in raceways and on *rolling elements* as a result of adverse ambient conditions. Improved cleanliness during mounting and in operation as well as the utilization of a suitable lubricant have a positive effect on the *bearing life*. These influences are taken into account in the *adjusted rating life calculation* and in the *modified life calculation* in accordance with DIN ISO 281. It is used for example to compare the effects of different lubricants. The *fatigue life* calculated for pulley bearings with this method in most cases is not equivalent to the *attainable life* as the *service life* is mainly limited by *wear*.

## Machining tolerances

In view of the *circumferential load* and the relatively high amount of load the outer rings must be a very tight *fit* in the pulley bore. Tolerances, see table below.

## Lubrication, sealing

The bearings are lubricated with a lithium soap base *grease of penetration 2* with *EP additives* (FAG rolling bearing grease *Arcanol L186V*).

External *sealing* of the bearings is provided by non-rubbing labyrinth *seals* or multi-collar rubbing seals. In both cases the labyrinths are filled with the same *grease* as the bearings. To supply the bearings with fresh grease and to increase the sealing effect, relubrication is effected at short intervals (depending on the amount of dirt) via the stationary shaft.

## Machining tolerances

Bearing	Seat	Diameter tolerance	Cylindricity tolerance
Spherical roller bearing as <i>locating bearing</i>	Shaft	h8	IT5/2
	Pulley bore	M7	IT5/2
Spherical roller bearing as <i>floating bearing</i>	Shaft	g6	IT5/2
	Pulley bore	M7	IT5/2
Cylindrical roller bearing <i>locating bearing, floating bearing</i>	Shaft	g6	IT5/2
	Pulley bore	N7	IT5/2

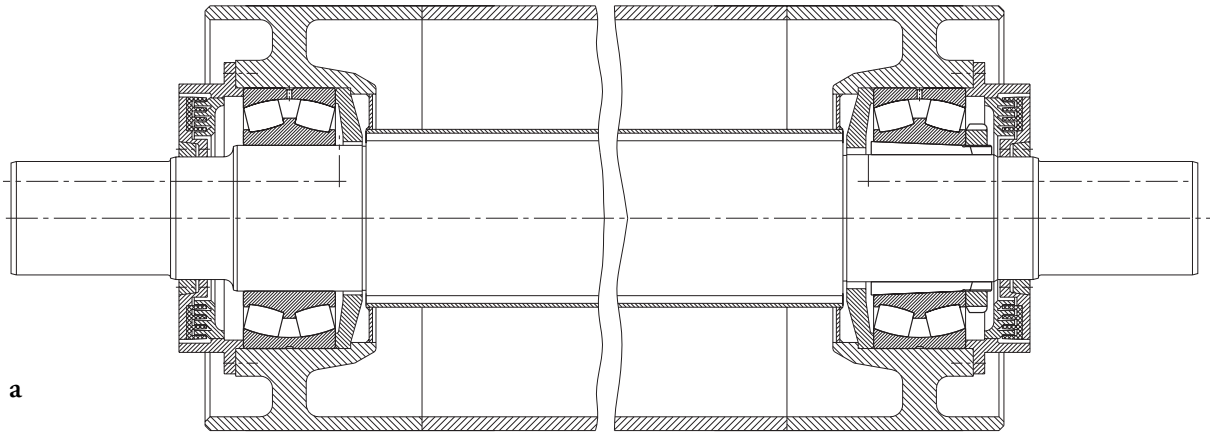

a

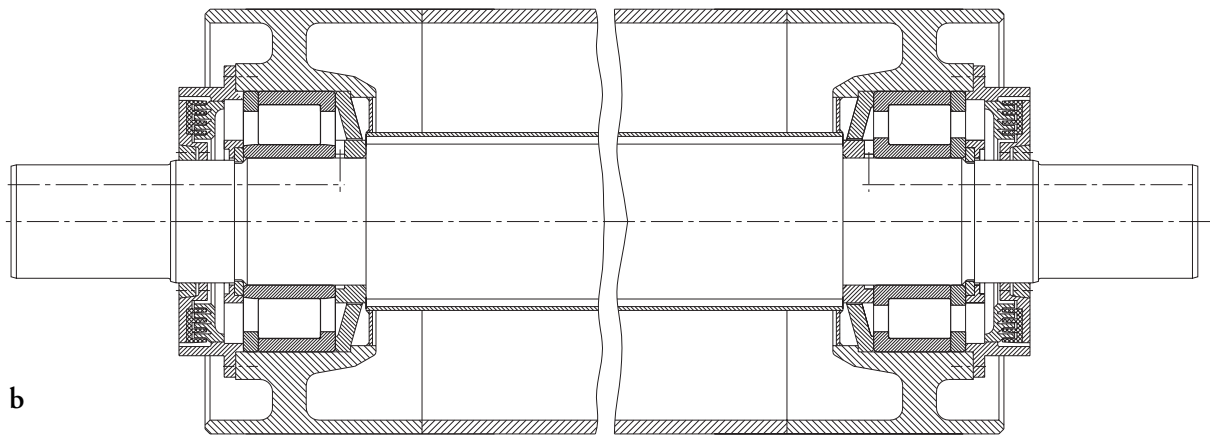

b

# Belt conveyor idlers

Many industries use belt conveyors for transporting bulk materials. The conveyors run on idlers and may extend over many miles; thus the number of idlers needed may be very large. Consequently, bearing mounting design is dictated by cost-saving considerations.

## Idler arrangement

Small belt conveyor systems feature idlers rigidly linked to a frame. Large belt conveyor systems feature idler garlands linked to each other by flexible joints.

# 85 Rigid idlers

## Operating data

Capacity  $I_m = 2,500$  t/h; Design: troughed belt with three idlers per station; the two outer idlers are arranged at an angle of  $30^\circ$  to the horizontal; distance between two idler stations  $l_R = 1,200$  mm; idler diameter  $d = 108$  mm, belt weight  $G_G = 35$  kg/m, dead-weight per roller  $G_R = 6$  kg; belt speed  $v = 3$  m/s; acceleration due to gravity  $g = 9.81$  m/s<sup>2</sup>.

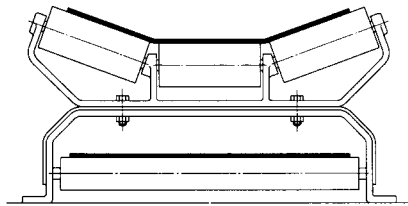

## Bearing selection

Idler mountings are usually internal bearing arrangements (hub mountings), i.e. the idler rotates about a stationary shaft.

Since a belt conveying plant requires a large number of roller bearings, deep groove ball bearings, which are produced in large quantities at low cost, are preferably used. This allows a simple and economical idler design.

## Bearing dimensioning

$$\text{Idler speed } n = \frac{v \cdot 60 \cdot 1,000}{d \cdot \pi} = 530 \text{ min}^{-1}$$

For ball bearings, the *speed factor*  $f_n = 0.4$ .

Load per idler station:

$$F = g \cdot l_R \cdot \left( \frac{I_m}{3.6 \cdot v} + G_G \right) = 9.81 \cdot 1.2 \cdot \left( \frac{2,500}{3.6 \cdot 3} + 35 \right) = 3,137 \text{ N}$$

For a trough angle of  $30^\circ$  the horizontal centre idler takes up approximately 65 % of this load. Thus the load on the centre idler is

$$F_R = 0.65 \cdot F + g \cdot G_R = 0.65 \cdot 3,137 + 9.81 \cdot 6 = 2,100 \text{ N} = 2.1 \text{ kN}$$

*Equivalent dynamic bearing load:*

$$P = F_r = F_R/2 = 1.05 \text{ kN}$$

The usual *index of dynamic stressing* for idler bearings  $f_L = 2.5 \dots 3.5$ . With  $f_L = 3$ , the required *dynamic load rating*  $C$  of a bearing

$$C = f_L \cdot P/f_n = 3 \cdot 1.05/0.4 = 7.88 \text{ kN}$$

Deep groove ball bearings FAG 6204.2ZR.C3 having a *dynamic load rating*  $C = 12.7$  kN are mounted.

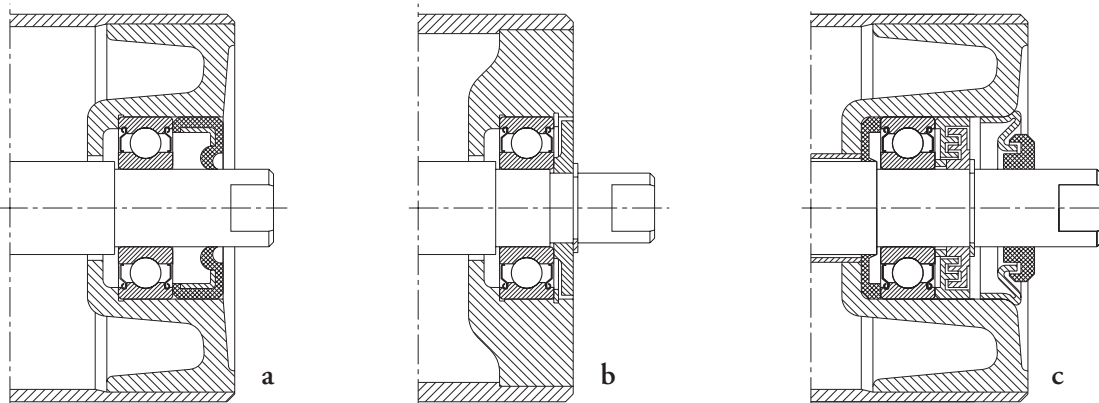

85a...c: Idler *sealing* variations

# 86 Idler garland

Generally, the *service life* of a bearing is not terminated by fatigue but by *wear* in raceways and on *rolling elements* as a result of contamination. Increased cleanliness during mounting and efficient *sealings* increase the *bearing life*. The *adjusted rating life calculation* is used for comparing different *seal* designs.

New idler bearings feature utmost cleanliness ( $V = 0.3$ ). However, in the course of operation the lubricant gets heavily contaminated by particles ( $V = 3$ ).

As the bearings in belt conveyor systems fail as a result of *wear*, the values obtained by the *adjusted rating life calculation* ( $L_{hna}$ ) usually are not equivalent to the actually attainable lives.

## Machining tolerances

The two deep groove ball bearings are mounted onto the idler shaft in a *floating bearing arrangement*. As the inner rings are subjected to *point load* the shaft is machined to h6 or js6. The outer rings are subjected to *circumferential load* and are pressed, therefore, into the idler end with an M7 interference fit.

## Lubrication, sealing and maintenance

The deep groove ball bearings FAG 6209.2ZR.C3 are packed, at the manufacturing plant, with a lithium soap base *grease* of *penetration class 2* which is sufficient for the entire *bearing service life*. Such a *grease* is also used for the *sealing*.

With idler bearings, both the *attainable life* and the lubricant *service life* may be considerably reduced by *grease* contamination during operation so that the *sealing* selected is decisive. Figs. 85a...c show various types of *sealing* for belt conveyor idlers.

Simple *seals* (figs. 85a and b) are used for clean environments. Fig. 85c shows an idler *seal* for brown coal open pit mining.

In addition to the rigidly troughed belt conveyors the garland type belt conveyors are being increasingly used. The idlers of each station are linked to each other by flexible joints. These joints may consist of a wire rope, a chain link (flat chain, round chain), hinge or similar.

Idler garlands accommodate impacts elastically; in the event of problems with a roller the individual garland is lowered and can be replaced relatively easily if necessary.

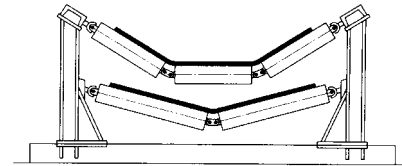

Fig. 86 shows idler garlands connected by chain links. These idlers are part of a conveying installation for rock phosphate. The bearings fitted are deep groove ball bearings FAG 6303.2ZR.C3.

## Machining tolerances

Idler ends to M7, shaft to h6 or js6.

## Lubrication, sealing, maintenance

The deep groove ball bearings (design .2ZR) are *sealed* by dust shields on both sides and filled with FAG rolling bearing *grease*, a lithium soap base grease of *penetration class 2*. The grease filling suffices for idler *service life*. A grease chamber with a non-rubbing labyrinth seal is provided at the outboard end. The second, adjacent chamber is closed by a shield pressed into the hub bore. A baffle plate protects the bearing against coarse particles.

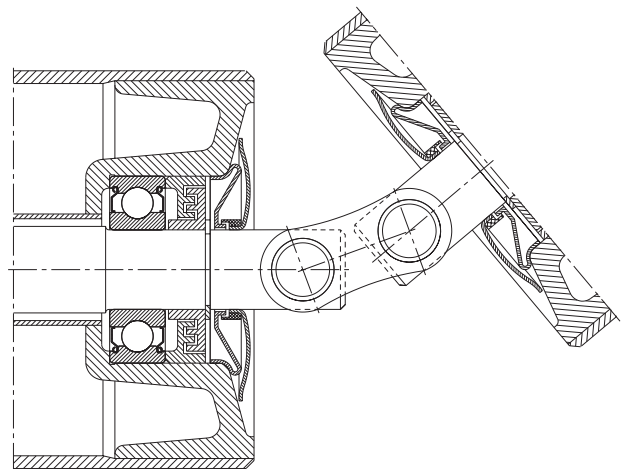

86: Idlers connected by chain link

# 87 Bucket wheel shaft of a bucket wheel excavator

Bucket wheel excavators are mainly used for brown coal open pit mining. The bucket wheel shaft carries the bucket wheel, the bull gear and the transmission housing. It is supported in the boom ends.

## Operating data

Input power 3 x 735 kW; theoretical conveying capacity 130,000 m<sup>3</sup> / day; bucket wheel speed 3 min<sup>-1</sup>.

## Bearing selection

The bearings of the bucket wheel shaft are subjected to high shock-type loads. Moreover, shaft deflections and misalignments must be expected. For this reason, only *self-aligning* roller bearings are suitable for supporting the shaft. At both shaft ends, spherical roller bearings FAG 239/900K.MB with withdrawal sleeves FAG AH39/900H are mounted as *locating bearings*. Thermal length variations of the shaft are compensated for by the elastic surrounding structure. The *radial clearance* of the spherical roller bearings is eliminated during mounting by pressing in the withdrawal sleeves. Only a split bearing can be provided on the bucket wheel side of the transmission box due to the solid forged shaft flange to which the bull gear is attached. If an unsplit bearing were to be provided on the opposite side of the transmission box it could only be replaced after dismantling the spherical roller bearing first.

For this purpose the entire bucket wheel shaft would have to be removed from the boom. This is avoided by using a split FAG cylindrical roller bearing of dimensions 1,000 x 1,220 x 170/100 mm on this side as well. The increased *axial clearance* of the two cylindrical roller bearings yields a *floating bearing arrangement*. Each bearing accommodates axial guiding loads in only one direction. The inner ring halves are attached to the shaft by means of separate locking rings. The calculated *nominal rating life* of all bearings is over 75,000 hours.

## Machining tolerances

All inner rings are subjected to *circumferential load*. The spherical roller bearings FAG 239/900K.MB are hydraulically fastened to the shaft (machined to h8) by means of withdrawal sleeves FAG AH39/900H. The split cylindrical roller bearings sit directly on the shaft which is machined to m6 in this place. All outer ring seats are toleranced to H7.

## Lubrication, sealing

The spherical roller bearings are *oil-bath* lubricated. The split cylindrical roller bearings are supplied by the draining *oil* from gearwheel lubrication. The *sealing* is a combination of labyrinth and rubbing *seal*. The labyrinths at the spherical roller bearings can be relubricated.

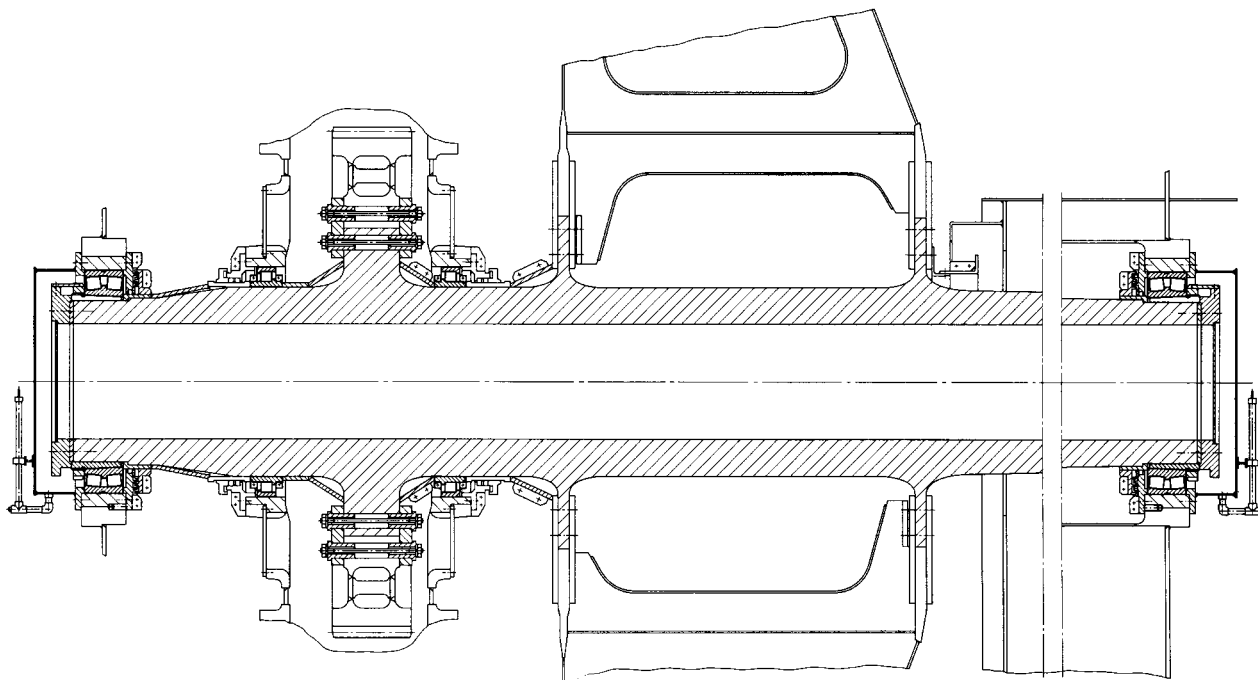

87: Bucket wheel mounting

# 88 Bottom sprocket of a bucket chain dredger

Bucket chain dredgers perform dredging work in waterways. The buckets are carried by a continuous chain from the bottom sprocket to the top sprocket over a large number of support rolls and back.

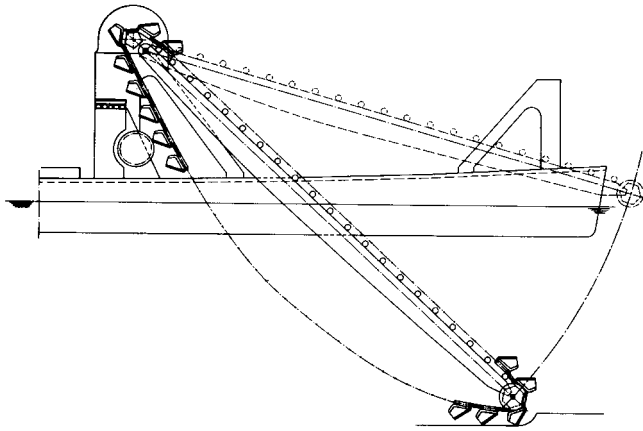

## Operating data

Ladder length 32 m; number of buckets 44; maximum dredging depth approximately 14 m; radial load on bottom sprocket approximately 250 kN.

## Bearing selection

Rugged operation and unvoidable misalignment between the housings at both ends of the sprocket

shaft call for *self-aligning bearings*. The bearings used are spherical roller bearings FAG 22240B.MB. Both bottom sprocket shaft bearings are designed as *locating bearings*. However, the bearings are not nipped axially, the housing being mounted with clearance in its ladder yoke seat. For easier bearing dismounting the shaft journal is provided with oilways and grooves for hydraulic dismounting.

## Machining tolerances

*Circumferential load* on the inner ring.  
Shaft journal to m6; housing to J7.

## Lubrication, sealing

The *grease* in the bearing (FAG rolling bearing *grease Arcanol L186V*) is renewed at intervals of 1 1/2 to 2 years coinciding with the general overhaul period of the dredger.

The bottom sprocket is constantly immersed in water. This requires waterproof *sealing*. Each bearing location is, therefore, fitted with two rubbing *seals* (shaft seals with bronze garter spring) and, in addition, with two packing rings (stuffing box). The shaft seals run on a bush of seawater-resistant material. The stuffing box can be retightened by means of a cover. *Grease* is regularly pumped into the labyrinth between the shaft seals and packing rings.

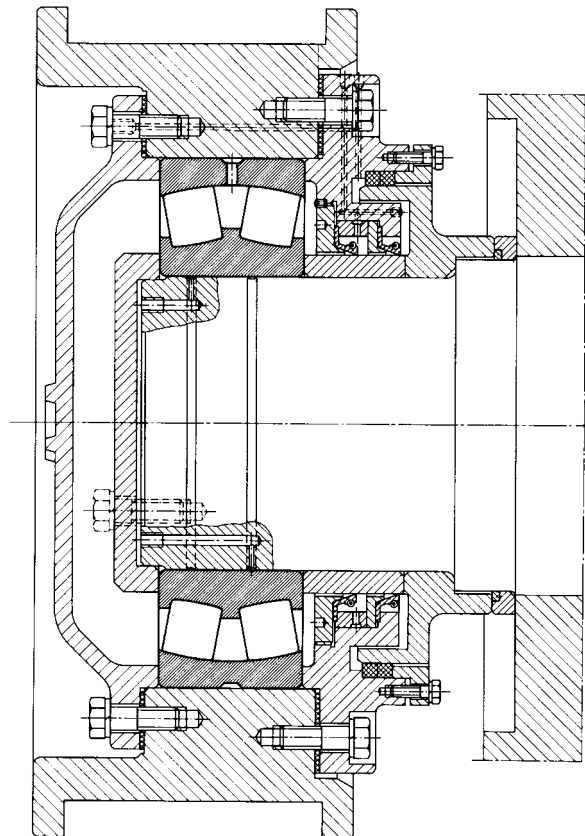

88: Bottom sprocket of a bucket chain dredger

# 89 Drive unit of a finished goods elevator

Finished-goods elevators are used, for example, for charging salt granulating plants. The material is conveyed in buckets attached to a chain. The chain is driven by the tumbler situated at the upper end.

## Operating data

Input power 22 kW; speed  $13.2 \text{ min}^{-1}$ ; radial bearing load 90 kN.

## Bearing selection

As shaft deflections and misalignments have to be expected the drive shaft is supported on *self-aligning bearings*. Selecting split spherical roller bearings FAG 222SM125T ensures that the heavy drive unit with the torque arm does not have to be dismantled in the event of repair.

As a result, the downtimes of the plant and the cost of production loss are considerably lower than they would be with one-piece bearings. To limit the variety of bearings used, a split spherical roller bearing was provided at the free shaft end as well.

Split spherical roller bearings have a cylindrical bore. Inner ring, outer ring and *cage* with roller set are split into halves.

The split inner ring halves are braced together by means of four dowel screws and attached to the shaft. Both outer ring halves are fitted together without a gap by means of two dowel screws.

The drive-end bearing is mounted with two locating rings and acts as the *locating bearing*; the bearing at the opposite end is the *floating bearing*. Split spherical roller bearings FAG 222SM125T are designed in such a way that they can be mounted into split series housings FAG SNV250 instead of one-piece spherical roller bearings with an adapter sleeve. Outside diameter, outer ring width and shaft seat diameter are identical. The theoretical *fatigue life*  $L_n$  of the bearings is over 100,000 hours.

## Machining tolerances

Shaft to h6...h9;  
housing to H7

## Lubrication, sealing

The bearings are lubricated with *grease*. The housings are connected to a central lubricating system so that continuous relubrication is ensured.

The shaft openings on both sides of the housing are each sealed by a two-lip *seal*.

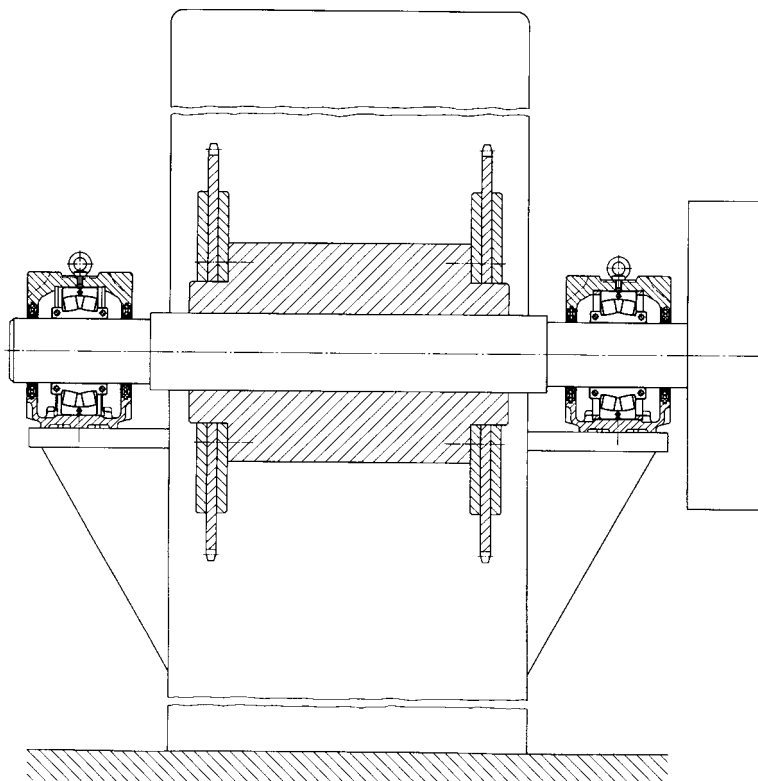

89: Drive unit of a finished goods elevator

# 90 Driving axle of a construction machine

Modern construction machines feature planetary gears in the wheel hub. This yields a considerable step-down ratio in a limited space, in the example shown  $i_g = 6.35$ . As the considerable drive torque is generated immediately at the wheel, a light drive shaft is sufficient.

## Planet wheel bearing arrangement

The planet wheel bearings must provide a high load carrying capacity in a limited space. This is achieved by means of assemblies where the outer ring raceway is integrated in the planet wheel. The *self-aligning* spherical roller bearing selected in the example smoothly compensates for small misalignments resulting from the deflection of the cantilever bearing journal under load. This yields a uniform contact pattern for the gearing, which is indicative of an optimal gear mesh. In the example shown the internal design of spherical roller bearing FAG 22309E.TVPB is used.

## Wheel mounting

As a rule, the wheel mounting on rigid axles of construction machines consists of two tapered roller bear-

ings which are axially *adjusted* against each other in *O arrangement* (larger *spread*) and with preload. In this way, deformations and tilting of the planetary gear are minimized and impermissible plastic deformations (brinelling marks) resulting from adverse operating conditions avoided.

The wheel bearings are tapered roller bearings FAG 32021X (in accordance with DIN ISO 355: T4DC105) and FAG 32024X (T4DC120).

## Machining tolerances

The rotating outer rings of the wheel mounting are subjected to *circumferential load*, the stationary inner rings to *point load*, therefore: journal to k6; hub to N7.

## Lubrication, sealing

Rolling bearings and gearing are washed around in the revolving wheel hub by the transmission *oil*.

Radial shaft *seals* protect the bearings from dirt and splash water.

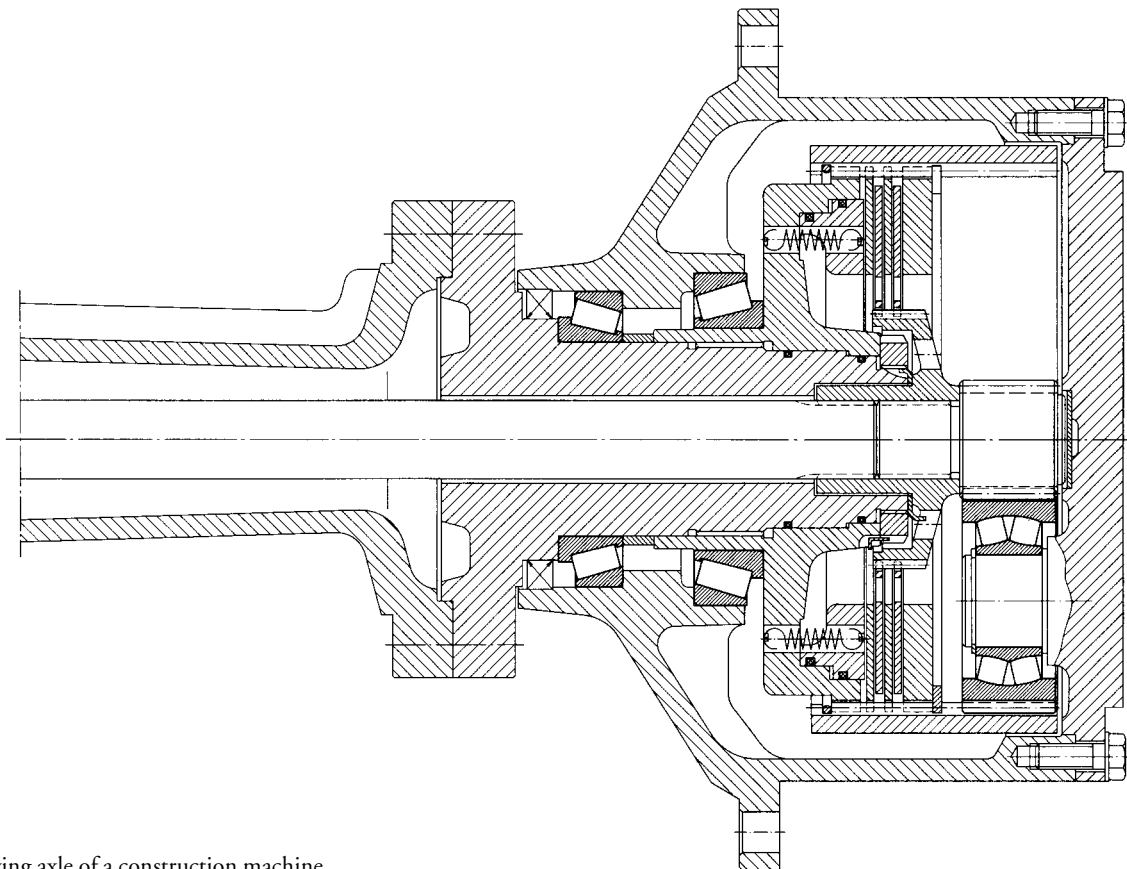

90: Driving axle of a construction machine

---

# 91 Vibrating road roller

---

The vibrations of such road rollers are produced by an eccentric shaft.

## Operating data

Speed of eccentric shaft  $n = 1,800 \text{ min}^{-1}$ ; radial load  $F_r = 238 \text{ kN}$ ; number of bearings  $z = 4$ ; required *nominal rating life*  $L_h \geq 2,000$  hours.

## Bearing selection, dimensioning

The centrifugal force from the imbalance weights on both sides of the roll are accommodated by two bearings each. The *equivalent dynamic load* per bearing is:

$$P = 1/z \cdot F_r = 1/4 \cdot F_r = 59.5 \text{ kN}$$

For the above conditions, an *index of dynamic stressing*  $f_L = 1.52$  and a *speed factor* of  $f_n = 0.302$  are obtained. The adverse *dynamic stressing* is taken into account by introducing a supplementary factor  $f_z = 1.2$ . Thus, the required *dynamic load rating* of one bearing

$$C = f_L/f_n \cdot P \cdot f_z = 1.52/0.302 \cdot 59.5 \cdot 1.2 = 359.4 \text{ kN}$$

On each side of the imbalance weights a cylindrical roller bearing FAG NJ320E.M1A.C4 (*dynamic load rating*  $C = 380 \text{ kN}$ ) is mounted. Due to the vibratory loads the bearings are fitted with an outer ring riding *machined brass cage* (M1A). The misalignment between the two bearing locations from housing machining inaccuracies is less than that permissible for cylindrical roller bearings.

## Machining tolerances

In view of the vibrations it is advisable to provide tight *fits* for both the bearing inner and outer rings. Axial guidance of the eccentric shaft is provided by the lips of the cylindrical roller bearings.

Eccentric shaft to k5, housing bore to M6.

## Lubrication, sealing

The bearings are lubricated by the *oil* splashed off from the imbalance weights. Additional guide plates improve lubricant supply to the bearings. *Mineral oils* with *EP additives* and anti-corrosion *additives* have proved to be suitable.

Internal *sealing* is provided by shaft seals, external sealing by O-ring seals.

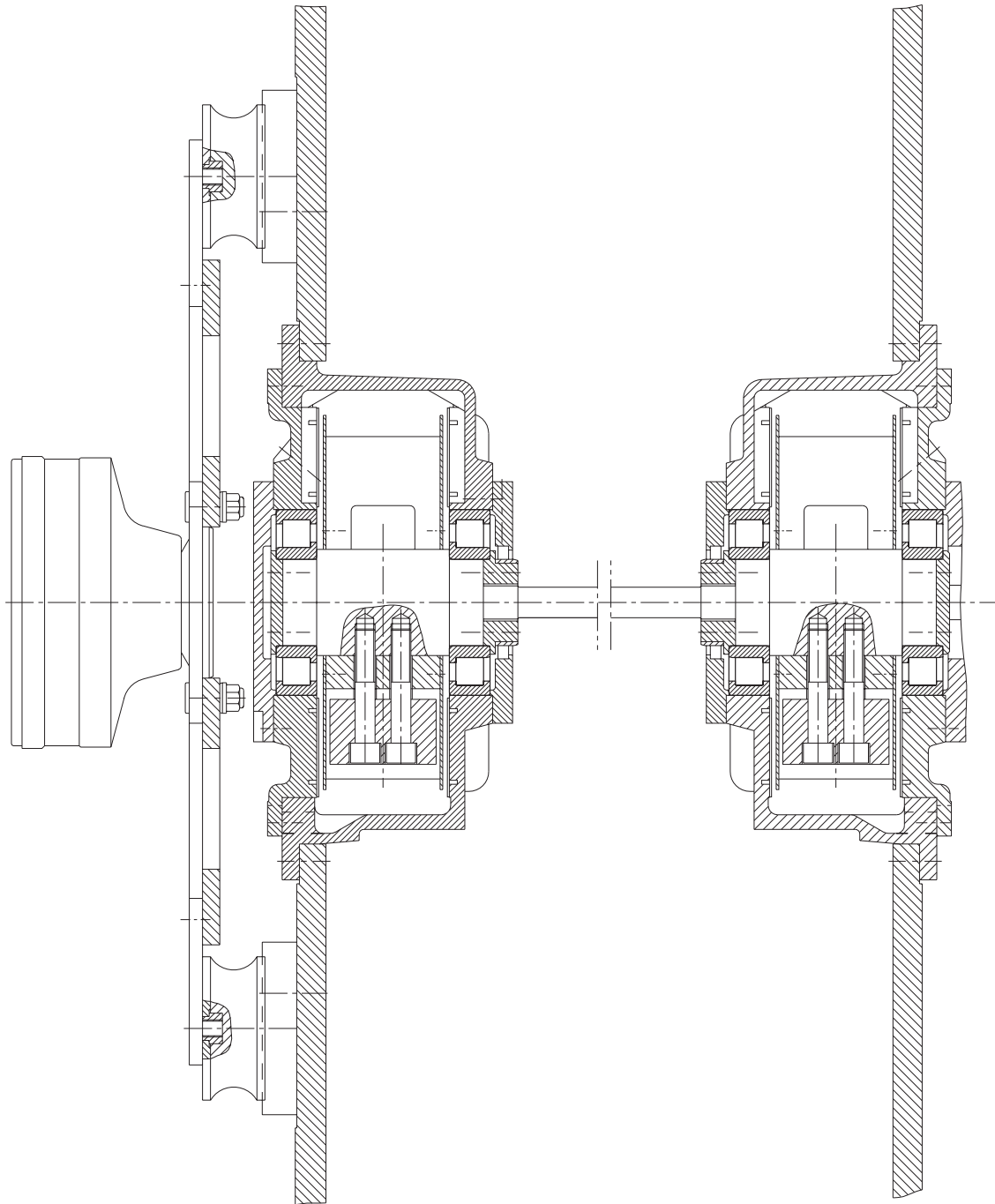

91: Vibrating road roller

# 92 Double toggle jaw crusher

Double toggle jaw crushers have a large mouth opening. They are used, for example, as primary crushers to prepare ballast for road building. The coarse crushing is followed by further crushing operations until an aggregate of the size and shape required, e.g. gravel or grit, is obtained.

## Operating data

Input power 103 kW; speed of eccentric shaft  $n = 210 \text{ min}^{-1}$ ; mouth opening 1,200 x 900 mm; eccentric radius 28 mm.

## Bearing selection, dimensioning

The pitman is fitted to the eccentric part of the horizontal shaft and actuates the swing jaw through a double toggle lever system. The inner bearings supporting the pitman must accommodate heavy crushing loads. The outer bearings transmit, in addition to these loads, the flywheel weight and the circumferential loads resulting from the drive. Due to the high loading and the rugged operation, spherical roller bearings are chosen. Spherical roller bearings FAG 23260K.MB are mounted as outer bearings and FAG 23176K.MB as inner bearings. The pitman bearing arrangement is of the *floating bearing* type. The outer bearing arrangement features a *locating bearing* at the drive side and the *floating bearing* at the opposite side. With an *index of dynamic stressing*  $f_L \approx 4.5$  the bearing arrangement is safely dimensioned with regard to *nominal rating life*.

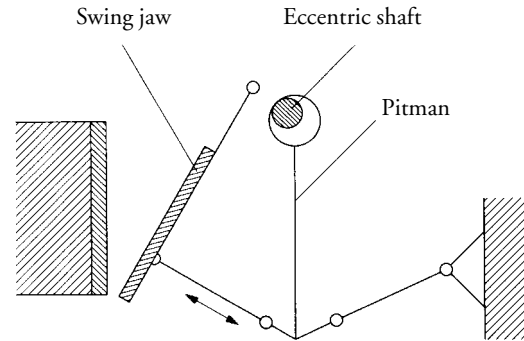

## Machining tolerances

The bearings are mounted on the shaft with adapter sleeves FAG H3260HGJ and FAG H3176HGJ, respectively. The bearing seats on the shaft are machined to h7 with a cylindricity tolerance IT5/2 (DIN ISO 1101), and the bores of housing and pitman to H7.

## Lubrication, sealing

*Grease* lubrication with a lithium soap base grease of *penetration class 2* with *EP additives* (FAG rolling bearing grease Arcanol L186V). The *relubrication interval* for the bearings is 2...3 months.

The bearings are *sealed* by multiple labyrinths. Once or twice a week, fresh *grease* is injected into the labyrinths.

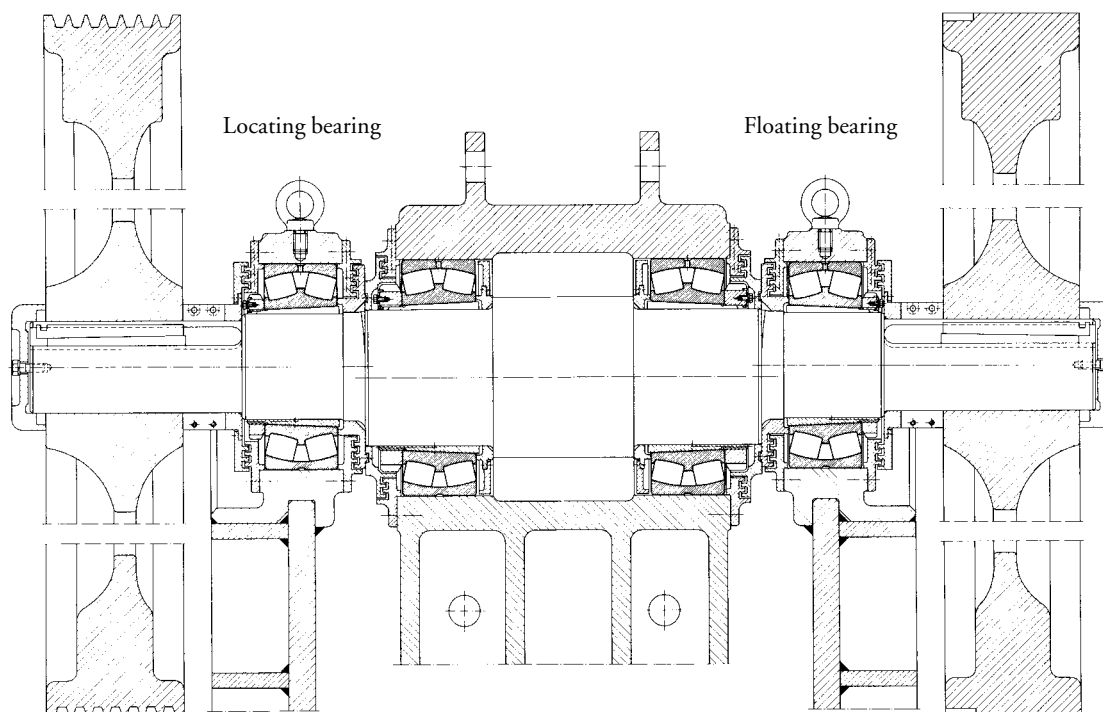

92: Bearing mounting of a double-toggle jaw crusher

# 93 Hammer mill

Hammer mills are mainly used for crushing ores, coal, and stone.

## Operating data

Hourly throughput 90...120 t of iron ore; input power 280 kW; rotor speed  $1,480 \text{ min}^{-1}$ , rotor weight including hammers approximately 40 kN; bearing centre distance 2,000 mm.

## Bearing selection

Due to the high loads and rugged operation, hammer mill rotors are mounted on spherical roller bearings. This *self-aligning bearing* type can compensate for misalignments of the two plummer block housings, and possible rotor deflections. Two spherical roller bearings FAG 23228EASK.M.C3 are mounted, one acting as the *locating bearing*, the other one as *floating bearing*. The increased *radial clearance C3* was selected because of the high speed. The bearing inner rings heat up more than the outer rings, causing the bearing clearance to be reduced during operation.

## Bearing dimensioning

The rotor weight imposes a radial load on the bearings. Added to this are unbalanced loads and shock loads whose magnitude can only be estimated. These loads are introduced in the *nominal rating life* calculation by multiplying the rotor weight  $G_R$  with a supplementary factor  $f_z$  of 2.5...3, depending on the operating conditions. The thrust loads acting on the bearings are so small they need not be taken into account in the *life* calculation.

With the *dynamic load rating*  $C = 915 \text{ kN}$ , the *speed factor*  $f_n = 0.32$  ( $n = 1,480 \text{ min}^{-1}$ ) and the rotor weight

$G_R = 40 \text{ kN}$ , the *index of dynamic stressing*  $f_L$  for one bearing:

$$f_L = C \cdot f_n / (0.5 \cdot G_R \cdot f_z) = 915 \cdot 0.32 / (20 \cdot 3) = 4.88$$

An  $f_L$  value of 3.5...4.5 is usually applied to hammer mills. Thus the bearings are adequately dimensioned with regard to *nominal rating life* ( $L_h$  approximately 100,000 h).

## Bearing mounting

The bearings are mounted on the rotor shaft with withdrawal sleeves FAG AHX3228. They are fitted into plummer block housings MGO3228K. Both housings (open design) are available for *locating bearings* (design BF) and for *floating bearings* (design BL). The split housings of series MGO were especially developed for mill applications. They are designed for *oil* lubrication and feature particularly effective *seals*.

## Machining tolerances

For mounting with sleeves, the shaft seats are machined to h7, with a cylindricity tolerance IT5/2 (DIN ISO 1101). The housing bores are machined to G6. Thus the requirement that the outer ring of the *floating bearing* must be displaceable within the housing is met.

## Lubrication, sealing

For reliable operation at high speeds, the bearings are oil bath lubricated. *Grease*-packed labyrinths prevent the ingress of foreign matter. To increase the *sealing* efficiency, grease is replenished frequently. Flinger grooves on the shaft, and *oil* collecting grooves in the housing covers retain the oil within the housing.

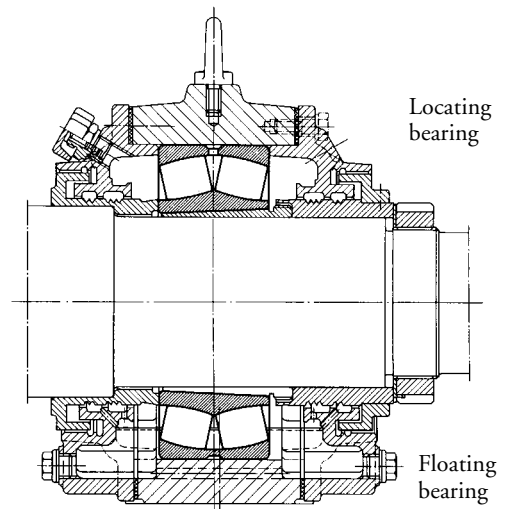
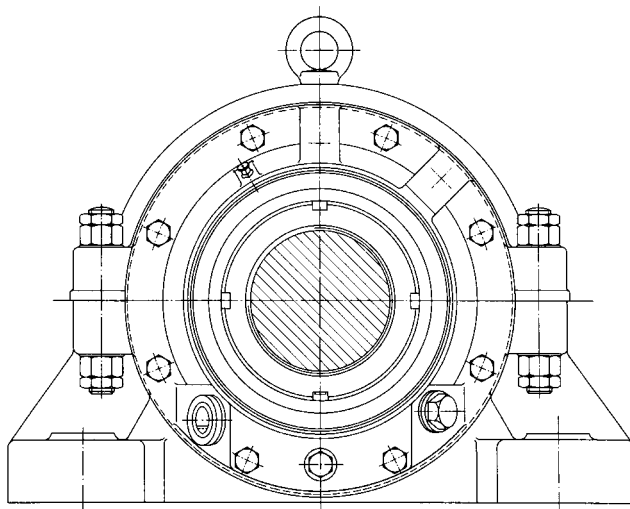

93: Hammer mill mounting

# 94 Double-shaft hammer crusher

Double-shaft hammer crushers are a special type of hammer crushers or hammer mills. They feature two contra-rotating shafts to which the hammers are attached. This type is especially suitable for crushing large-sized material with a high hourly throughput and optimum size reduction.

## Operating data

Hourly throughput 350...400 t of iron ore; input power 2 x 220 kW; rotor speed 395 min<sup>-1</sup>, rotor weight including hammers 100 kN; bearing centre distance 2,270 mm.

## Bearing selection

Due to the rugged operation, spherical roller bearings are mounted which can compensate for misalignment between the two plummer blocks and for shaft deflections.

## Bearing dimensioning

In addition to the loads resulting from the rotor weight, the bearings have to accommodate loads resulting from imbalances and shocks. They are taken into account by multiplying the rotor weight  $G_R$  by the supplementary factor  $f_z = 2.5$ . Small thrust loads need not be taken into account in the *life* calculation. The shaft diameter at the bearing locations determines the use of one spherical roller bearing FAG 23234EASK.M at each side. For the moderate speeds of this application normal *radial clearance* CN is satisfactory.

With the *dynamic load rating*  $C = 1,370$  kN, the *speed factor*  $f_n = 0.476$  ( $n = 395$  min<sup>-1</sup>) and the rotor weight  $G_R = 100$  kN, the *index of dynamic stressing*  $f_L$  per bearing:

$$f_L = C \cdot f_n / (0.5 \cdot G_R \cdot f_z) = 1,370 \cdot 0.476 / (50 \cdot 2.5) = 5.2$$

With this  $f_L$  value, which corresponds to a *nominal rating life*  $L_h$  of approximately 120,000 hours, the bearings are very adequately dimensioned.

## Bearing mounting

The bearings are mounted on the rotor shaft with withdrawal sleeves FAG AH3234 and mounted in FAG plummer block housings BNM3234KR.132887. One of the plummer blocks is designed as the *floating bearing* (closed on one side, design AL), the other one as the *locating bearing* (continuous shaft, design BF). The unsplit housings of series BNM were developed especially for hammer mills and crushers. They were designed for *grease lubrication* (grease valve) and feature particularly effective *seals*.

## Machining tolerances

The shaft seats are machined to h7, with a cylindricity tolerance IT5/2 (DIN ISO 1101).

The housing bores are machined to H7; this allows the outer ring of the *floating bearing* to be axially displaced.

## Lubrication, sealing

*Grease lubrication* with FAG rolling bearing grease *Arcanol L71V* is satisfactory for the speeds in this example. Relubrication is required at certain intervals. A *grease valve* protects the bearing against over-lubrication. Due to the adverse ambient conditions a double-passage labyrinth *seal* is provided. Frequent *grease* replenishment to the labyrinths improves sealing efficiency.

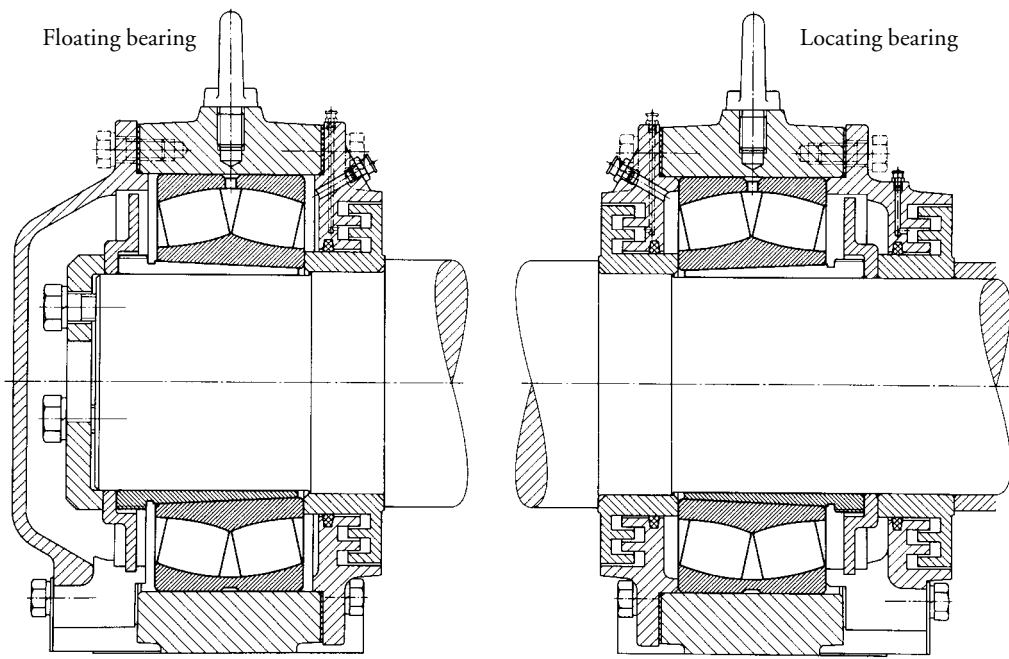

# 95 Ball tube mill

Tube mills are mostly used in the metallurgical, mining and cement industries. The tube mill described is used in an Australian gold mine for grinding auriferous minerals (grain sizes 4...30 mm) into grit by means of grinding bodies (balls). The grain size of the material depends on the number of balls and the quantity of added water. The grinding drum, which revolves around its horizontal axis, is lined with chilled-cast iron plates. Charged with the grinding stock, it is very heavy.

## Operating data

Drum: diameter 5,490 mm, length 8,700 mm; input power 3,850 kW; speed  $13.56 \text{ min}^{-1}$ ; drum mass when loaded 400 t; maximum radial load per bearing  $F_r = 1,962 \text{ kN}$ ; maximum thrust load  $F_a = 100 \text{ kN}$ ; bearing distance 11,680 mm, throughput 250 t/h.

## Bearing selection

### Trunnion bearings

As the drum rotates, the bearings have to accommodate, in addition to the heavy weight, constant shock-type loads caused by the grinding bodies. Both drum trunnions are supported on spherical roller bearings of series 239, 248 or 249. The bearings compensate for static and dynamic misalignments that can be caused by misalignments of the bearing seats (large bearing distance) or drum deflections. In this example, spherical roller bearings with a tapered bore (K 1:30), FAG 248/1500BK30MB are mounted both as the *locating bearing* at the drive end and as the *floating bearing* at the feed end. The bearings are mounted on the trunnion with a wedge sleeve.

### Drive pinion bearings

The drive pinion is supported on two spherical roller bearings FAG 23276BK.MB with adapter sleeve FAG H3276HG, in plummer block housings with Taconite-seals FAG SD3276TST.

## Bearing dimensioning

The dimensioning of the drum bearings is based on half the weight of the loaded drum

$$(400/2 \cdot 9.81 = 1,962 \text{ kN}).$$

The shock loads are taken into account by a shock factor  $f_z = 1.5$ . The required *nominal rating life* is 100,000 h; this corresponds to an *index of dynamic stressing*  $f_L = 4.9$ .

The *equivalent dynamic load*

$$P = f_z \cdot F_r + Y \cdot F_a = 2 \cdot 1.5 \cdot 1,962 + 4.5 \cdot 100 = 3,393 \text{ kN}$$

With a *dynamic load rating*  $C = 12,900 \text{ kN}$  the *index of dynamic stressing*:

$$f_L = C/P \cdot f_n = 12,900/3,393 \cdot 1.31 = 4.98 \text{ (} L_h > 100,000 \text{ h)}.$$

The bearings are very safely dimensioned with regard to *nominal rating life*.

The bearings are mounted in split FAG plummer block housings SZA48/1500HF (*locating bearing*) and SZA48/1500HL (*floating bearing*). The outer rings are tightly fitted into shell sleeves (e.g. made of grey-cast iron) in the lower housing half. They facilitate compensation of axial length variations. The sliding effect is enhanced by *grease* injected into the shell sleeve/housing joint.

## Machining tolerances

The *circumferentially loaded* inner rings are press-fitted on the trunnion. This is easily achieved by mounting them hydraulically on wedge sleeves. The *radial clearance* reduction and the *radial clearance* of the mounted bearing have to be observed (see table in FAG catalogue WL 41 520, chapter on spherical roller bearings).

The trunnions are machined to h9, with a cylindricity tolerance IT5/2 (DIN ISO 1101); the housing bores to H7.

## Lubrication, sealing

*Grease lubrication* with a lithium soap base grease of *penetration class 2* with *EP additives*, e. g. FAG rolling bearing grease *Arcanol* L186V. Continuous replenishment (approx. 5 g/h per bearing) ensures adequate lubrication.

The bearings are *sealed* by multiple labyrinths. Due to the extreme ambient conditions, the labyrinths are preceded by dirt baffle plates and rubbing seals (V-rings). This combination is also referred to as Taconite *sealing*. The labyrinths are also continuously replenished with approx. 5 g/h per labyrinth.

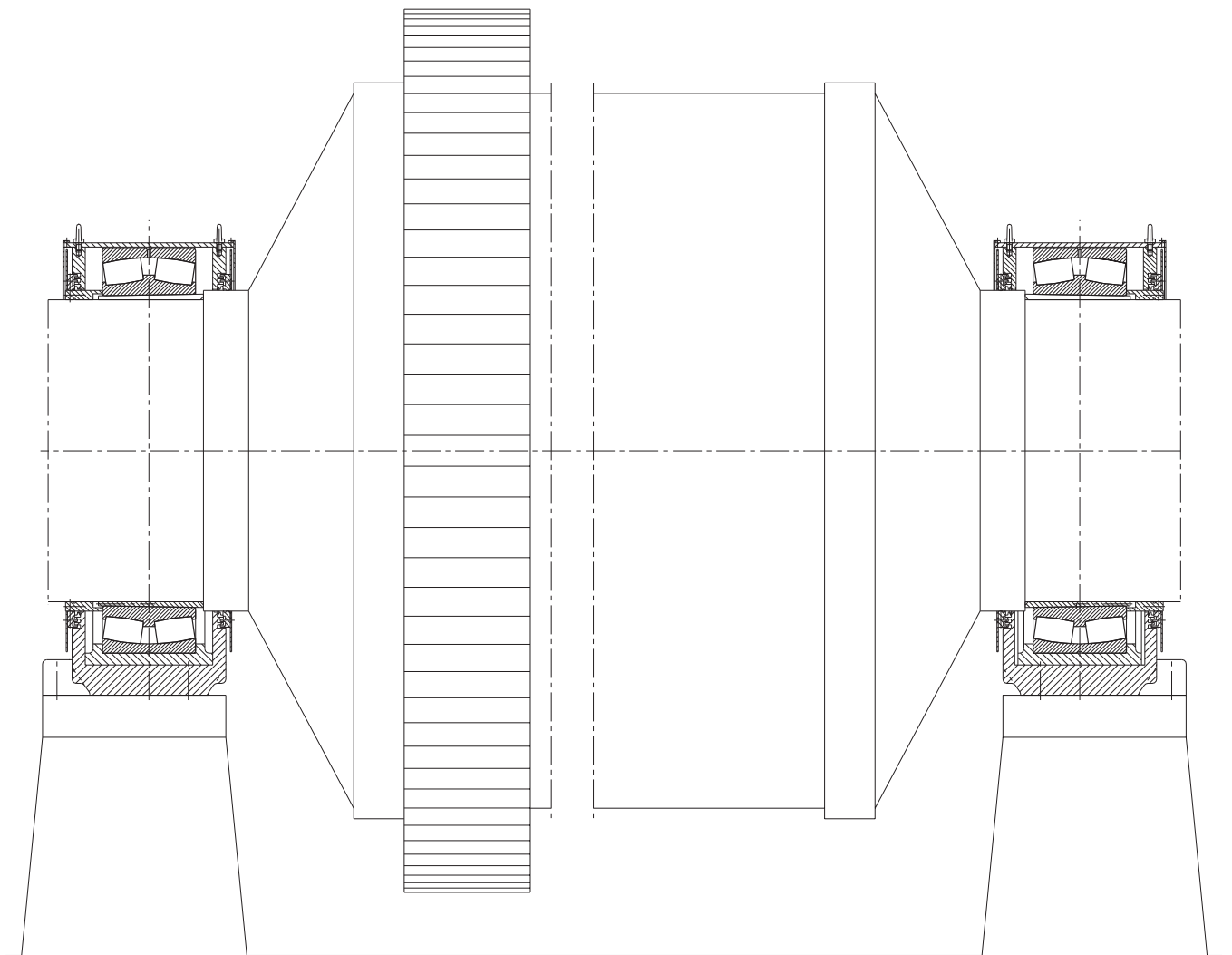

95: Ball tube mill mounting

---

# 96 Support roller of a rotary kiln

---

Rotary kilns for cement production can extend over a length of 150 m or more. The support rollers are spaced at about 30 m intervals.

## Operating data

Kiln outside diameter 4.4 m; support roller diameter 1.6 m; support roller width 0.8 m; radial load per support roller 2,400 kN; thrust load 700 kN. Speed  $5 \text{ min}^{-1}$ ; mass of support roller and housing 13 t.

## Bearing selection, dimensioning

For such rotary kilns FAG offers complete assemblies consisting of a twin housing SRL, the support roller with axle LRW, and the bearings. In this example the two support-roller bearings are mounted into split plummer block housings with a common base (frame) made of grey-cast iron. Spherical roller bearings FAG 24184B (*dynamic load rating*  $C = 6,200 \text{ kN}$ ) are mounted in a *floating bearing arrangement*, i. e. the

shaft can be displaced relative to the housing by a defined *axial clearance*.

In addition to the radial loads, the spherical roller bearings accommodate thrust loads resulting from displacements of the rotary kiln.

With an *index of dynamic stressing*  $f_L = 4.9$ , corresponding to a *nominal rating life*  $L_h = 100,000 \text{ h}$ , the bearings are adequately designed.

## Machining tolerances

Shaft to n6 (*circumferential load* on inner ring); housing bore to H7.

## Lubrication, sealing

*Grease lubrication* with a lithium soap base grease with *EP additives* (e. g. rolling bearing grease *Arcanol* L186V).

At the roller side the bearings are *sealed* with felt strips and *grease-packed* labyrinths.

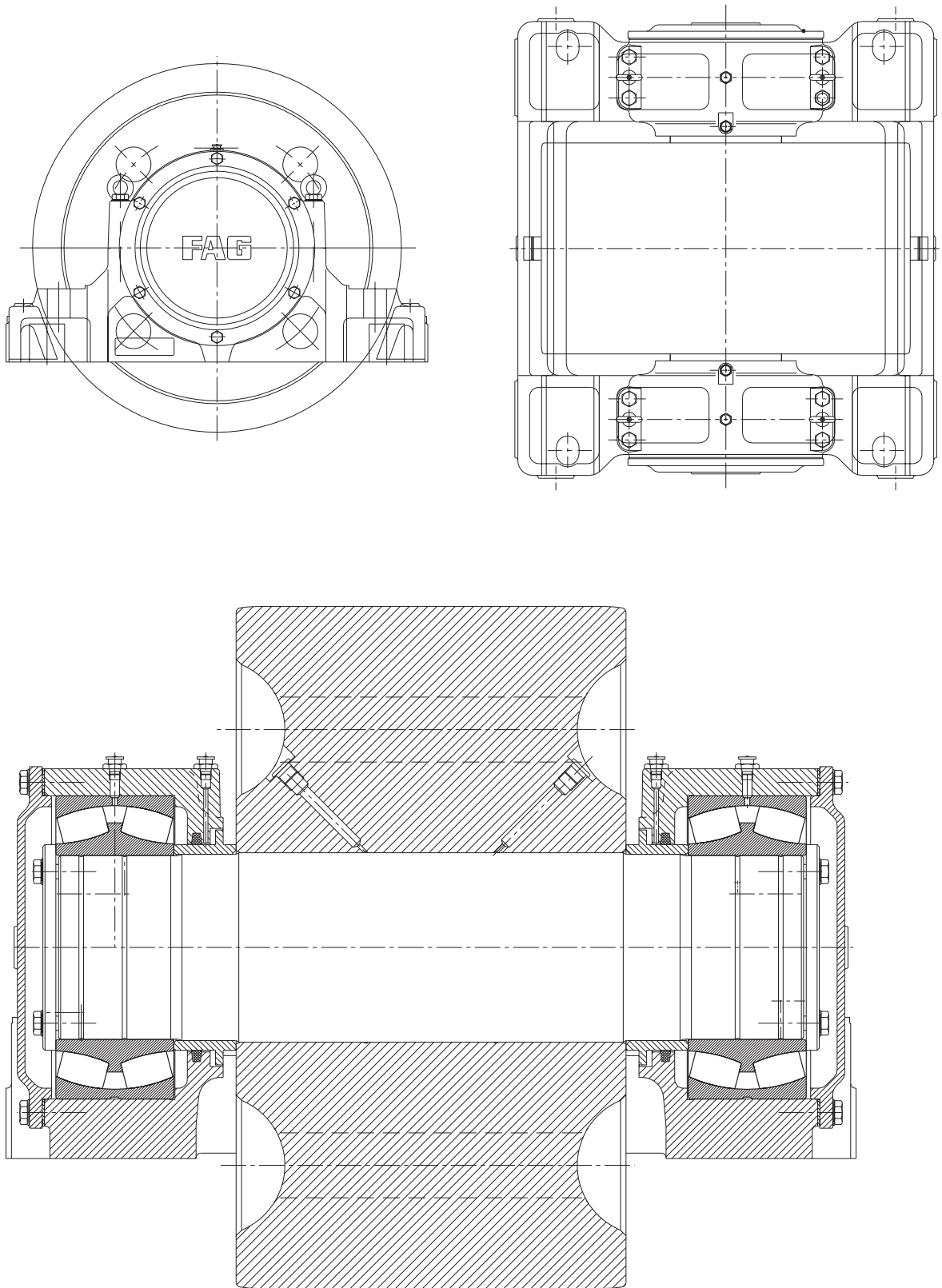

96: Support roller of a rotary kiln

---

# Vibrating machines

---

Vibrating screens are used for conveying and grading bulk material. They operate in mines, quarries, stone crushing plants and foundries, in the foodstuff and chemical industries, and in many other preparation and processing plants.

The main vibrating screen types are: two-bearing screens with circle throw, two-bearing screens with straight-line motion, and four-bearing screens.

Vibrator motors and vibrating road rollers also come under the category of vibrating machines.

## Selection of bearing type and bearing design

Rolling bearings in vibrating screens are stressed by high, mostly shock-type loads. To compound matters, the bearings, while rotating about their own axis, perform a circular, elliptical or linear vibrating motion. This results in high radial accelerations (up to 7 g) which additionally stress the bearings, and especially the *cages*. High operating speeds, usually with inaccurately aligned bearing locations, and pronounced shaft deflections are additional requirements which are best met by spherical roller bearings.

For these adverse operating conditions FAG spherical roller bearings with reduced bore and outside diameter tolerances and an increased *radial clearance* are used: The FAG standard design E.T41A is used for shaft diameters of 40...150 mm. The centrifugal forces of the unloaded rollers are accommodated by two pressed-steel, window-type *cages* and radially supported by a *cage* guiding ring in the outer ring.

Shafts with diameters of 160 mm and more are supported on vibrating screen bearings A.MA.T41A.

These bearings have a fixed centre lip on the inner ring and retaining lips on both sides. The split *machined* brass *cage* is of the outer-ring riding type.

## Bearing dimensioning

Vibrating screen bearings which are comparable with field-proven bearings can be dimensioned on the basis of the *index of dynamic stressing*  $f_L$ , provided that the boundary conditions are comparable as well.  $f_L$  values between 2.5 and 3 are ideal.

# 97 Two-bearing screen with circle throw

## Operating data

Screen box weight  $G = 35 \text{ kN}$ ; vibration radius  $r = 0.003 \text{ m}$ ; speed  $n = 1,200 \text{ min}^{-1}$ ; number of bearings  $z = 2$ ; acceleration due to gravity  $g = 9.81 \text{ m/s}^2$ .

## Bearing dimensioning

Two-bearing screens work beyond the critical speed; thus the common centroidal axis of the screen box and the unbalanced load does not change during rotation. The bearing load due to the screen box centrifugal force is:

$$F_r = 1/z \cdot G / g \cdot r \cdot (\pi \cdot n/30)^2 = \\ = 1/2 \cdot 35 / 9.81 \cdot 0.003 \cdot (3.14 \cdot 1,200/30)^2 = 84.5 \text{ kN}$$

To allow for the unfavourable *dynamic stressing*, the bearing load should be multiplied by the supplementary factor  $f_z = 1.2$ . Thus, the *equivalent dynamic load*

$$P = f_z \cdot F_r = 1.2 \cdot 84.5 = 101.4 \text{ kN}$$

With the *index of dynamic stressing*  $f_L = 2.72$  ( $L_h = 14,000 \text{ h}$ ) and the *speed factor*  $f_n = 0.34$  ( $n = 1,200 \text{ min}^{-1}$ ) the required *dynamic load rating*

$$C = f_L / f_n \cdot P = 2.72 / 0.34 \cdot 101.4 = 811.2 \text{ kN}$$

The recommended *index of dynamic stressing*  $f_L$  for vibrating screens is 2.5...3, corresponding to a *nominal fatigue life*  $L_h$  of 11,000 to 20,000 hours. Spherical roller bearings FAG 22324E.T41A with a *dynamic load rating* of 900 kN are chosen.

## Machining tolerances

The eccentric shaft features two spherical roller bearings, one as the *locating bearing*, the other as *floating bearing*. The inner rings are *point loaded* and mounted with a shaft tolerance of g6 or f6. The outer rings are *circumferentially loaded* and *fitted* tightly in the housing bore to P6.

## Lubrication, sealing

Circulating *oil* lubrication. *Mineral oils* with a minimum *viscosity* of  $20 \text{ mm}^2/\text{s}$  at operating temperature are recommended. The oil should contain *EP additives* and *anti-corrosion additives*.

Outer *sealing* is provided by a *grease-filled*, replenishable labyrinth. A flinger ring with an *oil* collecting groove prevents oil leakage. A V-ring is provided between flinger ring and labyrinth to separate *oil* and *grease*.

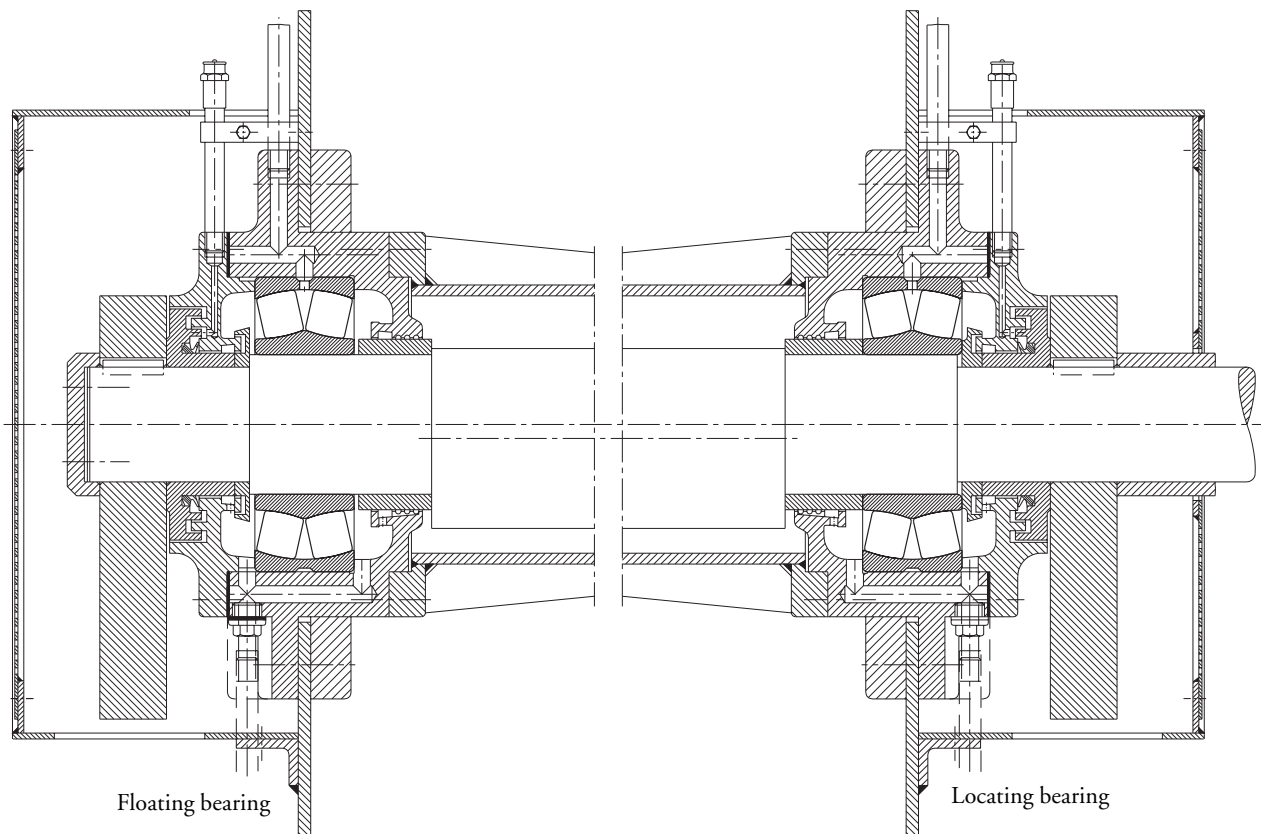

97: Two-bearing screen with circle throw

# 98 Two-bearing screen with straight-line motion

Basically, a two-bearing screen with straight-line motion consists of two contra-rotating, synchronous circular throw systems.

## Operating data

Screen box weight  $G = 33$  kN; imbalance weight  $G_1 = 7.5$  kN; amplitude  $r = 0.008$  m; speed  $n = 900$  min<sup>-1</sup>; number of bearings  $z = 4$ ; acceleration due to gravity  $g = 9.81$  m/s<sup>2</sup>.

## Bearing dimensioning

The bearing loads of a linear motion screen vary twice between the maximum value  $F_{\text{rmax}}$  and the minimum value  $F_{\text{rmin}}$  during one revolution of the eccentric shafts.

For calculation of these loads, the distance  $R$  between the centres of gravity of imbalance weight and the pertinent bearing axes is required. Weights  $G$  and  $G_1$ , amplitude of linear vibration  $r$  and distance  $R$  have the following relationship:

$$G \cdot r = G_1 \cdot (R - r)$$

In this example  $R = 0.043$  m

When the centrifugal forces act perpendicular to the direction of vibration, the maximum radial load  $F_{\text{rmax}}$  is calculated as follows:

$$F_{\text{rmax}} = 1/z \cdot G_1 / g \cdot R \cdot (\pi \cdot n/30)^2 = 1/4 \cdot 7.5 / 9.81 \cdot 0.043 \cdot (3.14 \cdot 900/30)^2 = 73 \text{ kN}$$

The radial load is at its minimum ( $F_{\text{rmin}}$ ) when the directions of centrifugal forces and vibration coincide. The radial load is then

$$F_{\text{rmin}} = 1/4 \cdot G_1/g \cdot (R - r) \cdot (\pi \cdot n/30)^2 = 1/4 \cdot 7.5/9.81 \cdot 0.035 \cdot (3.14 \cdot 900/30)^2 = 59.4 \text{ kN}$$

Since the radial load varies between the maximum and minimum according to a sinusoidal pattern, the *equivalent dynamic load*  $P$  with the supplementary factor  $f_z = 1.2$  is thus:

$$P = 1.2 \cdot (0.68 \cdot F_{\text{rmax}} + 0.32 \cdot F_{\text{rmin}}) = 1.2 \cdot (0.68 \cdot 73 + 0.32 \cdot 59.4) = 82.4 \text{ kN}$$

With the *index of dynamic stressing*  $f_L = 2.53$  ( $L_h = 11,000$  h) selected for vibrating screens and the *speed factor*  $f_n = 0.372$  ( $n = 900$  min<sup>-1</sup>) the required *dynamic load rating*

$$C = f_L/f_n \cdot P = 2.53/0.372 \cdot 82.4 = 560.4 \text{ kN}$$

The spherical roller bearing FAG 22320E.T41A with a *dynamic load rating* of 655 kN is chosen.

## Machining tolerances

The *locating bearings* of the two eccentric shafts are at the gear end, the *floating bearings* at the drive end. The inner rings (*point load*) are have loose *fits*, i. e. the shaft is machined to g6 or f6. The outer rings are *circumferentially loaded* and tightly fitted in the housing bore (P6).

## Lubrication, sealing

*Oil lubrication.* For lubricating the spherical roller bearings at the locating end, the *oil* thrown off by the gear suffices. A flinger ring is provided for this purpose at the opposite end. Baffle plates (A) at the housing faces maintain an oil level reaching about the centre point of the lowest rollers. The oil level is such that the lower gear and the flinger ring are partly submerged. The oil level can be checked with a sight glass. A flinger ring and a V-ring in the labyrinth provide *sealing* at the drive shaft passage.

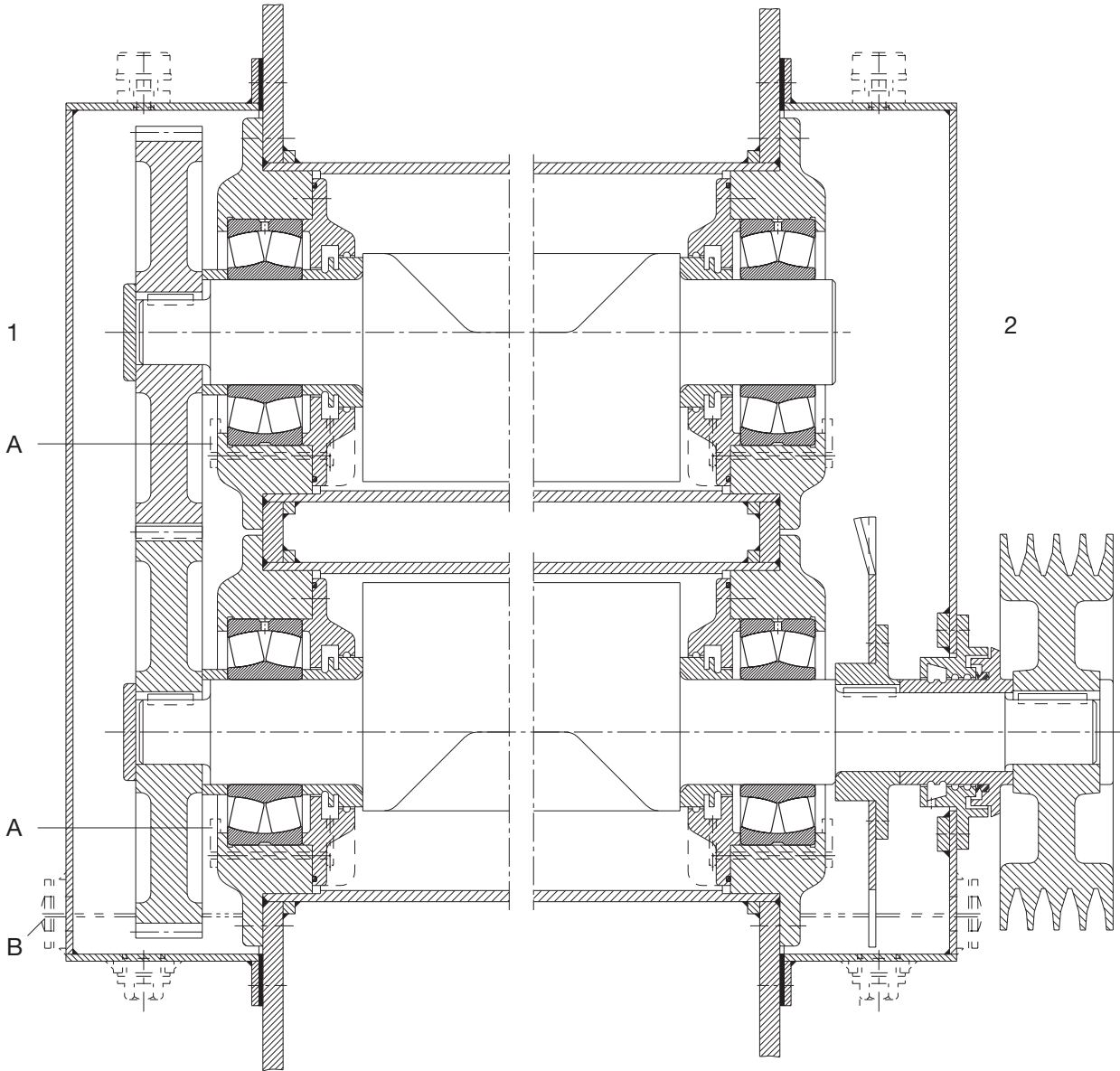

- 1 Locating bearing
- 2 Floating bearing
- A Baffle plates
- B Sight glass

98: Bearing mounting of a two-bearing screen with straight-line motion

# 99 Four-bearing screen

The vibration radius of a four-bearing screen is a function of the shaft eccentricity. It is not variable; therefore these screens are also called rigid screens.

## Operating data

Screen box weight  $G = 60 \text{ kN}$ ; eccentric radius  $r = 0.005 \text{ m}$ ; speed  $n = 850 \text{ min}^{-1}$ ; number of inner bearings  $z = 2$ ; acceleration due to gravity  $g = 9.81 \text{ m/s}^2$ .

## Bearing dimensioning

### Inner bearings

For the two inner bearings of a four-bearing screen, which are subjected to vibration, the *equivalent dynamic load*  $P$  is the same as for the two-bearing screen with circular throw

$$P = 1.2 \cdot F_r = 1.2/z \cdot G/g \cdot r \cdot (\pi \cdot n/30)^2 = 1.2/2 \cdot 60/9.81 \cdot 0.005 \cdot (3.14 \cdot 850/30)^2 = 145.4 \text{ kN}$$

The required *dynamic load rating*

$$C = f_L/f_n \cdot P = 2.93/0.378 \cdot 145.4 = 1,127 \text{ kN}$$

Spherical roller bearings FAG 22328E.T41A (*dynamic load rating*  $C = 1,220 \text{ kN}$ ) are chosen.

### Outer bearings

The stationary outer bearings are only lightly loaded since the centrifugal forces of the screen box are balanced by counterweights. Generally spherical roller

bearings of series 223 are also used. The bearing size is dictated by the shaft diameter so that the load carrying capacity is high and *fatigue life* calculation unnecessary. Since these bearings are not subjected to vibration, the standard design with normal clearance is satisfactory. In the example shown spherical roller bearings FAG 22320EK (*dynamic load rating*  $C = 655 \text{ kN}$ ) are chosen.

## Machining tolerances

### Inner bearings

The inner bearings (a *locating-floating bearing arrangement*) feature *point load* on the inner rings: The shaft is machined to g6 or f6. The bearings are fitted tightly into the housing (P6).

### Outer bearings

The outer bearings – also a *locating-floating bearing arrangement* – are mounted on the shaft with withdrawal sleeves. The shaft is machined to h8, the housing bore to H7.

## Lubrication, sealing

*Grease lubrication* with a lithium soap base *grease* of *penetration* class 2 with anti-corrosion and extreme pressure *additives*. Grease supply between the roller rows through lubricating holes in the outer rings. *Sealing* is provided by grease-packed, relubricatable labyrinths.

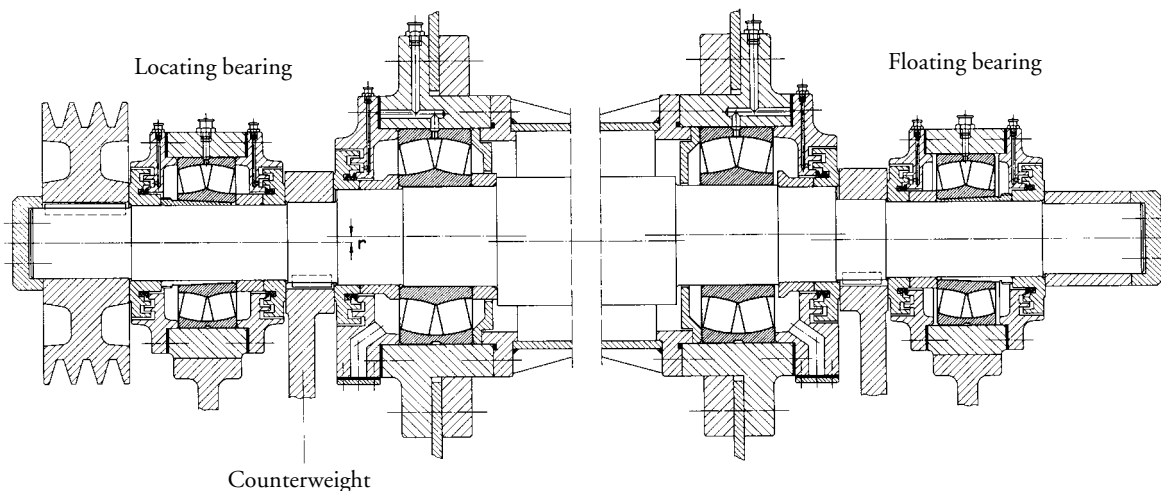

# 100 Vibrator motor

The vibrations of vibrating equipment are generated by one or several activators. An electric motor with an imbalance rotor is an example of such an activator. It is referred to as a "vibrator motor". Vibrator motors are primarily mounted in machinery for making prefabricated concrete parts, in vibrating screens and vibrating chutes.

## Operating data

Input power  $N = 0.7 \text{ kW}$ , speed  $n = 3,000 \text{ min}^{-1}$ .  
The bearings are loaded by the rotor weight and the centrifugal forces resulting from the imbalances: maximum radial load on one bearing  $F_r = 6.5 \text{ kN}$ .

## Bearing selection, dimensioning

Due to the high centrifugal forces, the load carrying capacity of the deep groove ball bearings usually used for medium-sized electric motors is not sufficient for this application. Vibrator motors are, therefore, supported on cylindrical roller bearings. The arrangement shown incorporates two cylindrical roller bearings FAG NJ2306E.TVP2.C4; the *dynamic load rating* of the bearings is  $73.5 \text{ kN}$ .

The adverse dynamic bearing stressing by the centrifugal forces is taken into account by a supplementary factor  $f_z = 1.2$ . Considering this supplementary factor, the *equivalent dynamic load*

$$P = 1.2 \cdot F_r = 7.8 \text{ kN}.$$

With the *speed factor*  $f_n = 0.26$  ( $n = 3,000 \text{ min}^{-1}$ ), the *index of dynamic stressing*

$$f_L = C/P \cdot f_n = 73.5/7.8 \cdot 0.26 = 2.45$$

This  $f_L$  value corresponds to a *nominal rating life* of  $10,000 \text{ h}$ . Thus the bearings are correctly dimensioned.

## Machining tolerances

Shaft to k5; housing to N6.

The bearing outer rings carry *circumferential load* and are, therefore, tight *fits*. Since the inner rings are subjected to *oscillating loads*, it is advisable to fit them tightly onto the shaft as well. With *non-separable bearings* this requirement would make bearing mounting and dismounting extremely complicated. Therefore, *separable* cylindrical roller bearings of design NJ are used.

## Bearing clearance

The initial *radial clearance* of the bearings is reduced by tight *fits*. Further *radial clearance* reduction results from the different thermal expansion of inner and outer rings in operation. Therefore, bearings of *radial clearance* group C4 (i. e. *radial clearance* larger than C3) are mounted.

To prevent detrimental axial preloading, the inner rings are assembled so that an *axial clearance* of  $0.2 \dots 0.3 \text{ mm}$  exists between the roller sets of the two bearings and the lips (*floating bearing arrangement*).

## Lubrication, sealing

Both bearings are lubricated with *grease*. Lithium soap base greases of *penetration* class 2 with *EP additives* have proved successful. Relubrication after approximately 500 hours.

Since the vibrator motor is closed at both ends, gap-type *seals* with grooves are satisfactory.

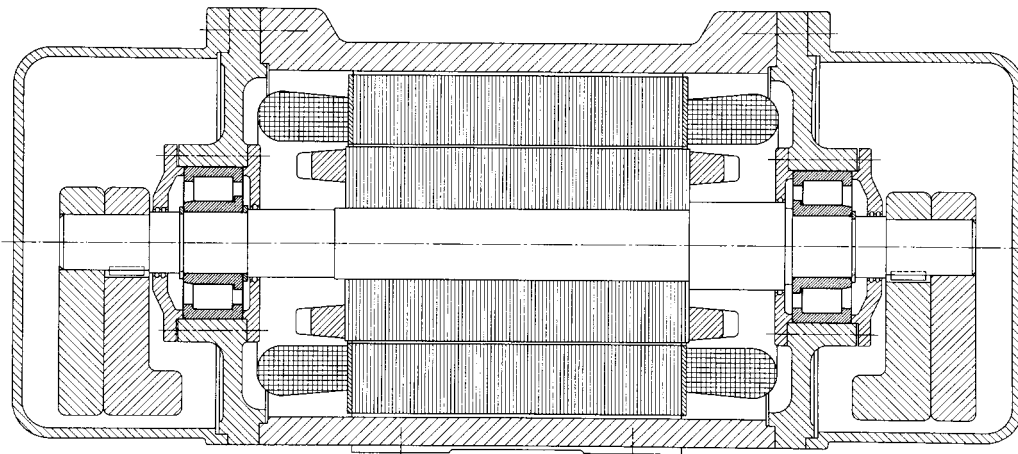

100: Imbalance rotor bearings of a vibrator motor

# 101–103 Large capacity converters

Converters perform swinging motions and are occasionally rotated up to 360°. Bearing selection is, therefore, based on static load carrying capacity. Important criteria in bearing selection are, besides a high *static load rating*, the compensation of major misalignments and length variations. Misalignment invariably results from the large distance between the bearings and from trunnion ring distortion and deflection. The considerable length variations are due to the large differences in converter temperature as the converter is heated up and cools down.

## Bearing selection

Example 101 – showing the conventional design – features one spherical roller bearing each as *locating bearing* and as *floating bearing*. The housing of the *floating bearing* is fitted with a sleeve. This simplifies axial displacement of the spherical roller bearing. To minimize the frictional resistance, the bore of the sleeve is ground and coated with dry lubricant (molybdenum disulphide).

For thrust load calculation a coefficient of friction of  $\mu = 0.1 \dots 0.15$  is used.

Example 102 shows two spherical roller bearings mounted in the housings as *locating bearings*. Axial displacement is permitted by two collaterally arranged linear bearings (rollers) which provide support for one of the two housings. With this design the amount of friction to be overcome during axial displacement is limited to the rolling contact friction occurring in the linear bearings (coefficient of friction  $\mu \approx 0.05$ ).

## Bearing dimensioning

For converters, the *index of static stressing*  $f_s = C_0/P_0$  should be more than 2; see calculation example.

$C_0$  = static load rating of the bearing

$P_0$  = equivalent static load

## Operating data

Calculation example: two spherical roller bearings and two linear bearings (example 102).

*Locating bearing*: Radial load  $F_{rF} = 5,800$  kN;

*Floating bearing*: Radial load  $F_{rL} = 5,300$  kN;

Thrust load from drive  $F_a = 800$  kN and from axial displacement  $0.05 \cdot F_{rL} = 265$  kN;

trunnion diameter at bearing seat 900 mm.

Two spherical roller bearings FAG 230/900K.MB (*static load rating*  $C_0 = 26,000$  kN, thrust factor  $Y_0 = 3.1$ ) are mounted.

### Locating bearing

$$P_0 = F_{rF} + Y_0 \cdot (F_a + 0.05 \cdot F_{rL}) \\ = 5,800 + 3.1 \cdot (800 + 265) = 9,100 \text{ kN}$$

$$\text{Index of static stressing } f_s = 26,000 / 9,100 = 2.85$$

### Floating bearing

$$P_0 = F_{rL} + Y_0 \cdot 0.05 \cdot F_{rL} \\ = 5,300 + 3.1 \cdot 265 = 6,120 \text{ kN}$$

$$\text{Index of static stressing } f_s = 26,000 / 6,120 = 4.24$$

Both bearings are thus safely dimensioned. Five cylindrical rollers (80 x 120 mm) each are required for the two linear bearings. The hardness of the guide rails (raceways) is 59...65 HRC.

## Machining tolerances

Bearings with a cylindrical bore: trunnion to m6. Bearings with a tapered bore and hydraulic sleeve: trunnion to h7. The trunnions are machined with a cylindricity tolerance IT5/2 (DIN ISO 1101). The support bores in the housing have H7 tolerance. Tighter *fits* should not be used in order to prevent bearing ovality which might otherwise result from the split housing.

## Lubrication, sealing

Converter bearings are lubricated with *grease*. Lithium soap base greases of *penetration* class 2 with *EP* and anti-corrosion *additives* (e. g. FAG rolling bearing grease *Arcanol* L186V) are a good choice. Efficient *sealing* is achieved by graphited packing rings.

## Split rolling bearings

Steel mills often demand that the bearing at the converter drive end are replaceable without dismantling the drive unit. This requirement is satisfied by split spherical roller bearings (example 103).

For cost reasons, split bearings are usually used as replacement bearings.

101: Converter bearings  
(two spherical roller bearings)

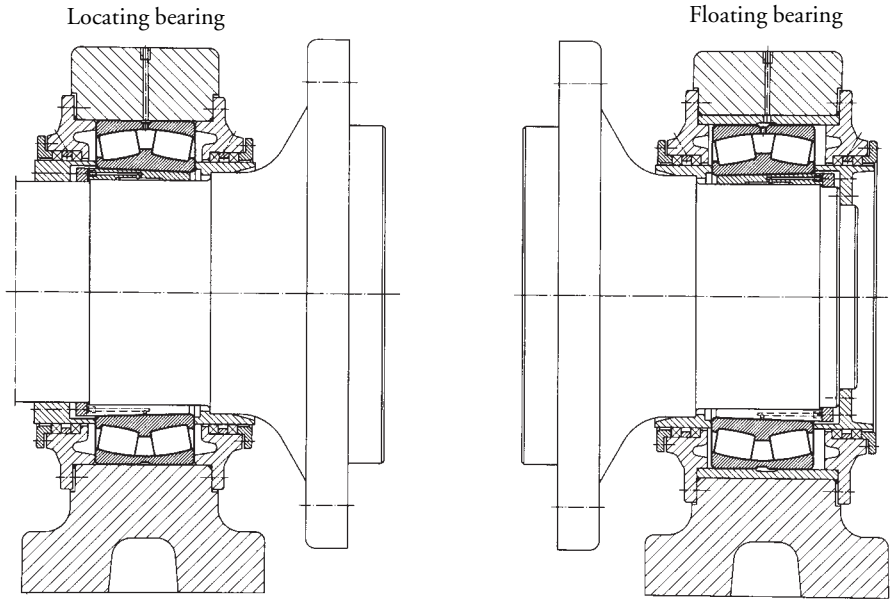

102: Converter bearings  
(two spherical roller bearings,  
two linear bearings)

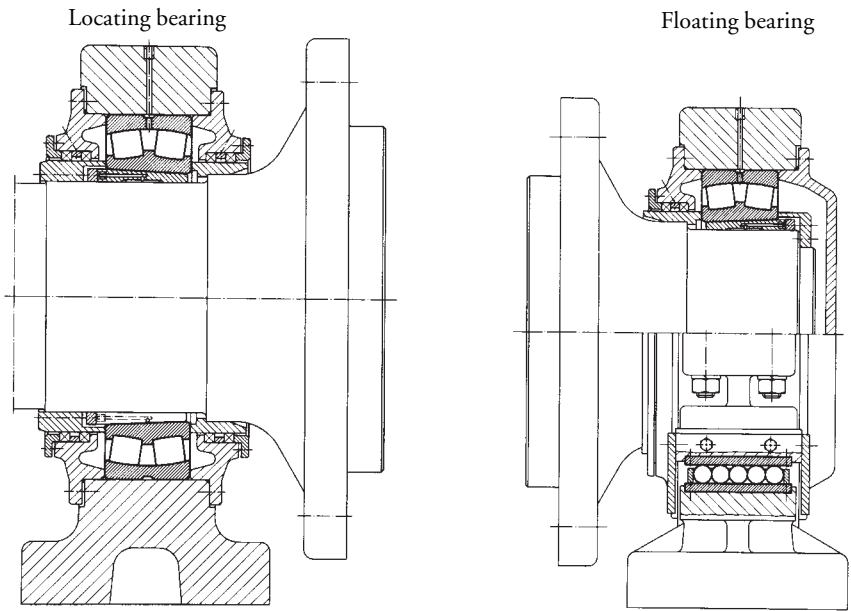

103: Locating bearing end with split  
spherical roller bearing

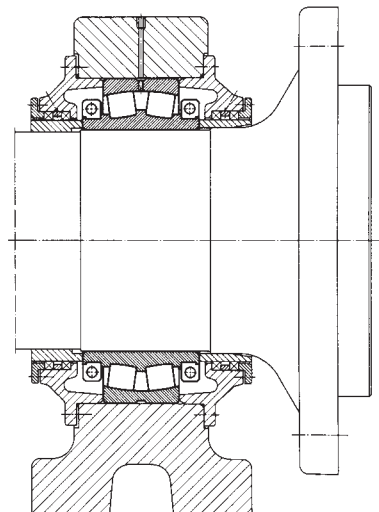

# 104 Roll bearings of a four-high cold rolling stand for aluminium

## Operating data

Back-up rolls: roll diameter 1,525 mm  
roll body length 2,500 mm

Work rolls: roll diameter 600 mm  
roll body length 2,500 mm

Maximum rolling load 26,000 kN  
Maximum rolling speed 1,260 m/min

## Selection of the back-up roll bearings (fig. 104a)

### Radial bearings

The high radial loads are best accommodated, in a limited mounting space and at high speeds, by cylindrical roller bearings. One four-row cylindrical roller bearing FAG 527048 (dimensions 900 x 1,220 x 840 mm) is mounted at each roll end. The bearings feature pin-type cages and reach a *dynamic load rating* of  $C = 31,500$  kN.

The increased *radial clearance* C4 is required as the inner rings are fitted tightly and heat up more in operation than the outer rings.

Machining tolerances:

Roll neck  $+0.350 / +0.440$  mm, chock to H7.

### Thrust bearings

Since thrust loads in strip rolling stands are low, *thrust bearings* are used that are small compared to the *radial bearings*. The back-up roll is supported at both ends by a double-row tapered roller bearing FAG 531295A (dimensions 400 x 650 x 240 mm) with a *dynamic load rating* C of 3,450 kN.

Machining tolerances: Shaft to f6.

The cups are not supported radially; axially, they are *adjusted* by means of helical springs.

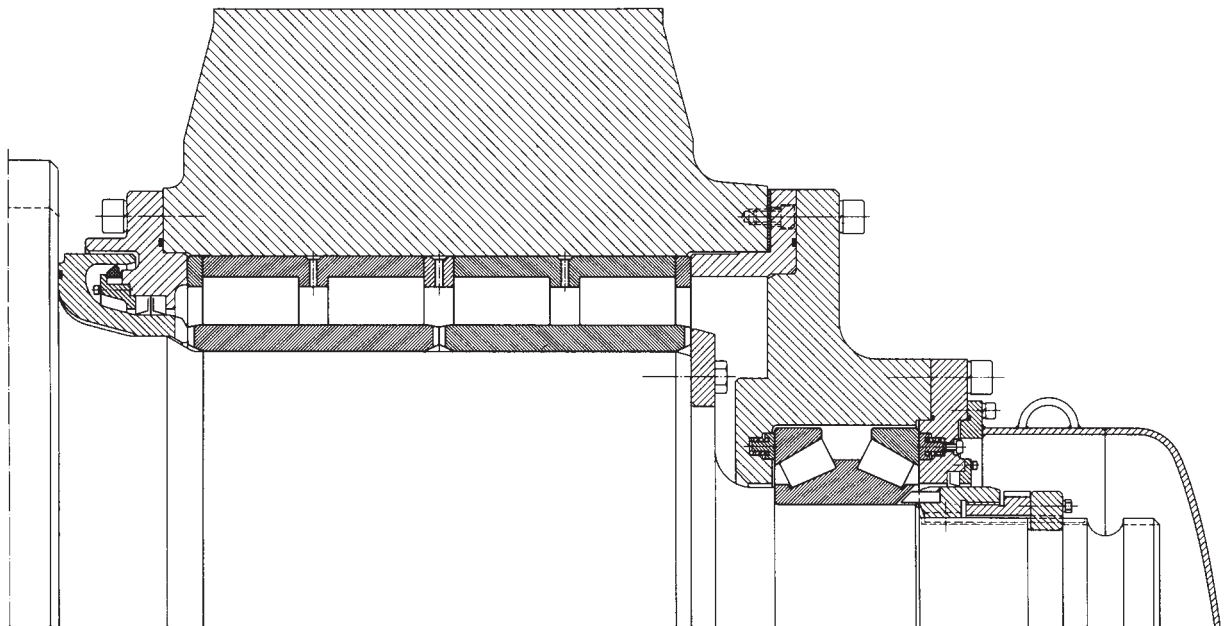

104a: Back-up roll mounting of a four-high cold rolling stand for aluminium (identical bearing arrangements at drive end and operating end)

## Selection of the work roll bearings (figs. 104b, c)

### Radial bearings

Each roll end is supported on two double-row cylindrical roller bearings FAG 532381.K22 (dimensions 350 x 500 x 190 mm). The bearings feature reduced *tolerances* so that all roller rows are evenly loaded, *machined* brass cages and an increased *radial clearance* C3.

Machining tolerances

Roll neck to p6; chock bore to H6.

### Thrust bearings

*Locating bearing* end (operating end): two angular contact ball bearings FAG 7064MP.UA in *X* arrangement. Any two bearings of *universal design* UA can be matched in *X* or *O* arrangement, yielding a bearing pair

with a narrow *axial clearance*. The angular contact ball bearings accommodate the thrust loads from the rolls. *Floating bearing* end (drive end): a deep groove ball bearing FAG 61972M.C3 merely provides axial guidance for the chock.

Machining tolerances: Sleeve to k6; outer rings not radially supported.

### Lubrication

All bearings supporting the back-up rolls and work rolls are *oil-mist* lubricated. A high-*viscosity oil* with *EP additives* is used as the cylindrical roller bearings – especially at the back-up rolls – are heavily loaded and have to accommodate operating temperatures of up to 70 °C.

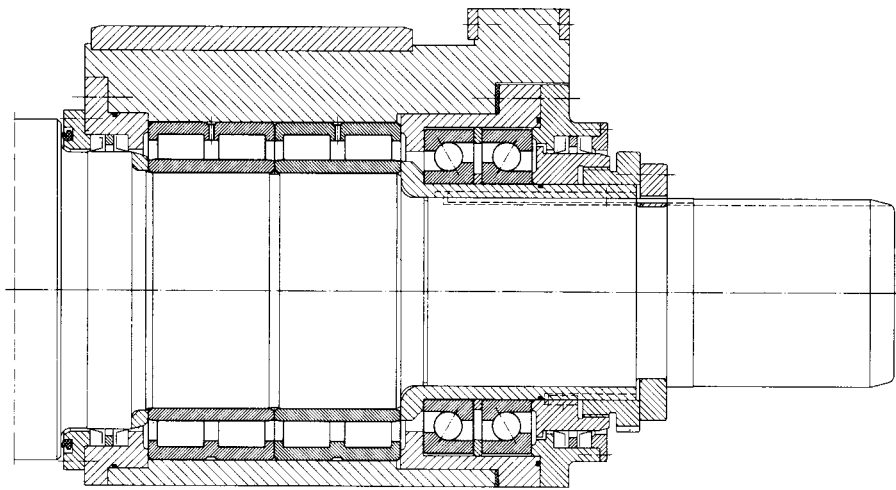

104b: Work roll bearings, operating end

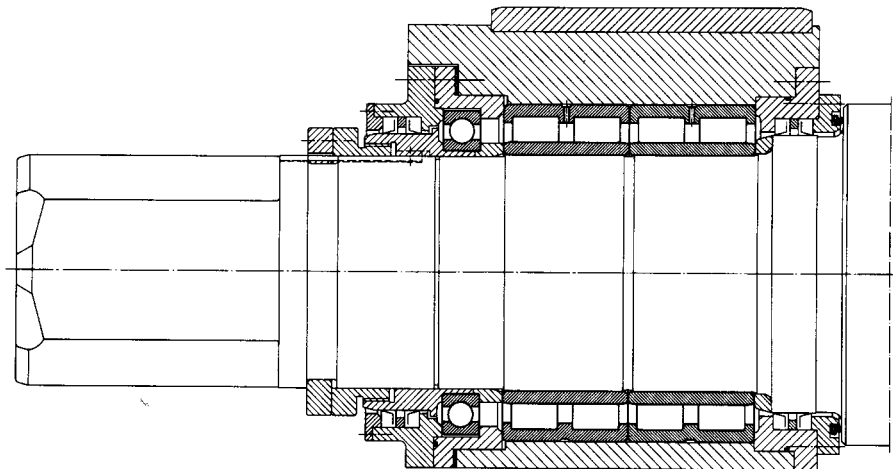

104c: Work roll bearings, drive end

# 105 Work rolls for the finishing section of a four-high hot wide strip mill

Work roll bearings are often exposed to large amounts of water or roll coolant. In addition, considerable amounts of dirt have to be accommodated in hot rolling mills. Therefore, the bearings must be efficiently *sealed*. As a rule, they are lubricated with *grease*, which improves *sealing* efficiency. Operators of modern rolling mills endeavour to reduce *grease* consumption and damage to the environment caused by escaping grease-water emulsion.

## Operating data

Roll body diameter 736 mm; roll body length 2,235 mm; rolling speed 3.5...15 m/s.

## Bearing selection, dimensioning

Four-row tapered roller bearings have proved to be a good choice for work rolls. They accommodate not only high radial loads but also thrust loads, and they require only little mounting space. The bearings have a sliding fit on the roll neck, allowing rapid roll changes. In the example shown, sealed four-row tapered roller bearings FAG 563681A (dimensions 482.6 x 615.95 x 330.2 mm) are used.

The *service life* of work roll bearings is mainly dictated by the loads, rolling speed, lubrication and cleanliness. Open bearings, as a rule, do not reach their *nominal rating life* due to adverse lubricating and cleanliness conditions. On the other hand, the *modified life calculation* for sealed bearings usually yields  $a_{23}$  factors  $> 1$ , i. e. the *attainable life* exceeds the *nominal rating life*. In spite of the lower *load rating*, the value is generally higher than that reached by an open bearing of the same size.

## Lubrication, sealing

The bearings are filled with relatively small amounts of high-quality rolling bearing *grease*. On each side they feature a double-lip rubbing *seal*. The inner lip prevents *grease* escape from the bearing; the outer lip protects the bearing from moisture that might have penetrated into the chock. No relubrication is required during rolling operation and roll change. The amount of *grease* provided during assembly usually suffices for the duration of one chock regrinding cycle, i. e. for 1,000...1,200 hours of operation. The chocks are fitted with the conventional external *seals* (collar seals). These are filled with a moderately priced, environmentally compatible sealing grease.

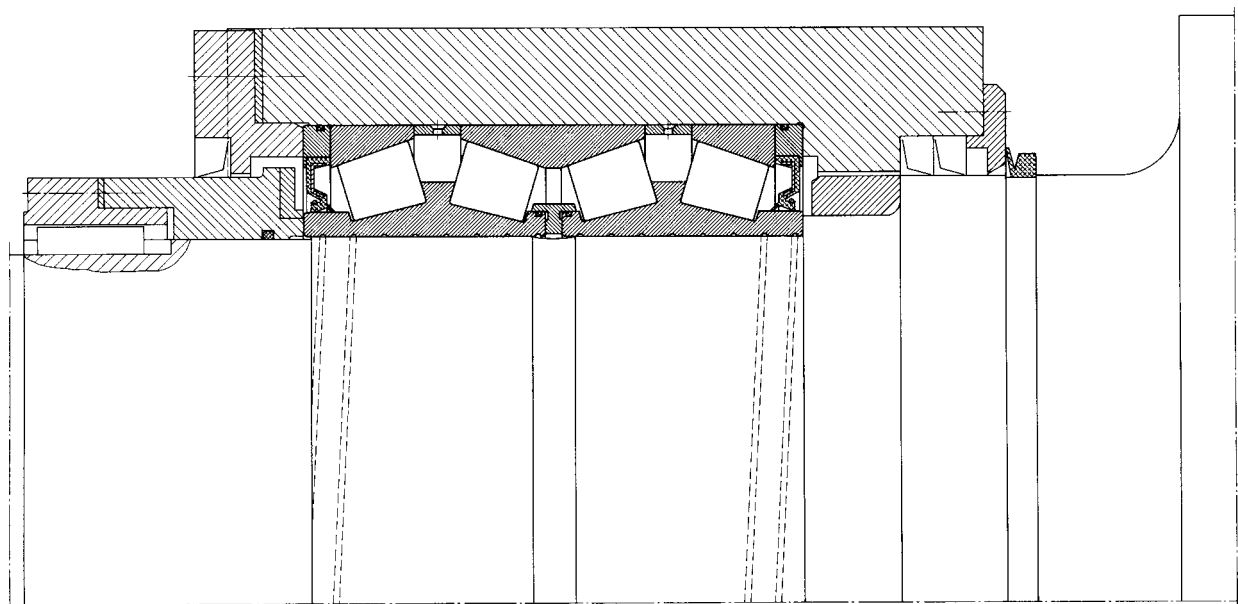

105: Work roll mounting for the finishing section of a four-high hot wide strip mill

# 106 Roll mountings of a two-high ingot slab stand or ingot billet stand

## Operating data

Roll diameter 1,168 mm (46"); roll body length 3,100 mm (122"); rolling speed 2.5...5 m/s; yearly output of 1 million tons. The mill operates as a reversing stand, i.e. the rolled material moves back and forth, and the sense of rotation of the rolls alternates from pass to pass.

## Roll bearings

The work rolls in this example are also supported on multi-row tapered roller bearings. These bearings require relatively little mounting space and accommodate high radial and thrust loads. The rolls are supported at each end on a four-row tapered roller bearing FAG 514433A (dimensions 730.25 x 1,035.05 x 755.65 mm).

The bearing rings are loosely fitted on the roll neck and in the chocks for easy mounting and dismounting. The cones creep on the roll neck in circumferential direction. To reduce *wear* and heat generation, the fitting surfaces are usually supplied with *grease* through a helical groove in the bearing bore.

## Lubrication

The tapered roller bearings are lubricated with *grease* which is continually supplied through grooves in the faces of cone and spacer ring.

Excess *grease* escapes through the bores in the central cup and in the spacers.

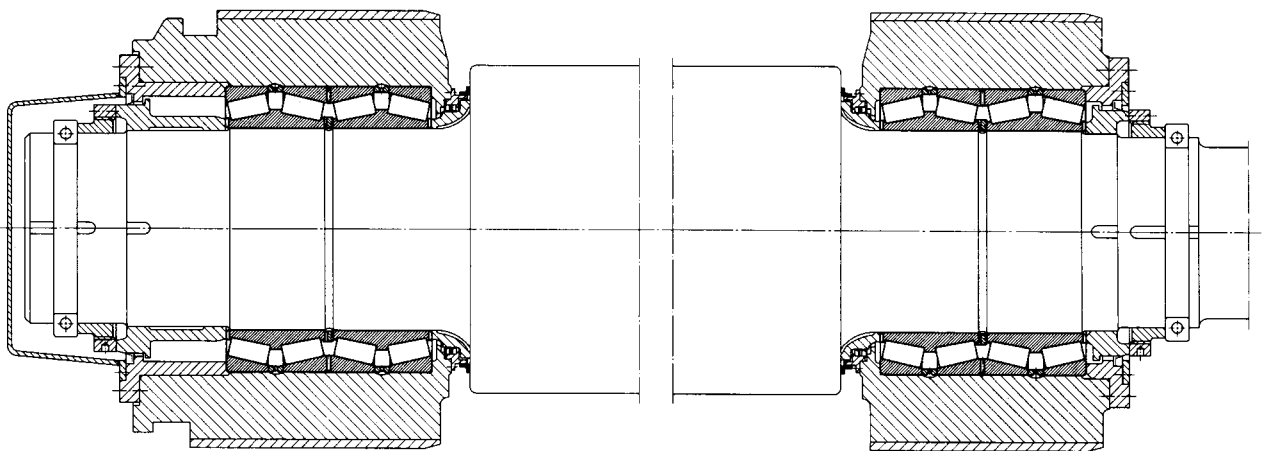

106: Roll mounting of a two-high ingot slab stand or ingot billet stand

---

# 107 Combined reduction and cogging wheel gear of a billet mill

---

## Operating data

The billet mill is designed for a monthly output of 55,000 tons. The mill comprises a roughing and a finishing section, each with two vertical and two horizontal stands in alternate arrangement. The drive of the vertical stands is on top; with this arrangement the foundations are not as deep as for a bottom drive; on the other hand, the top drive involves a greater overall height.

Rated horsepower 1,100/2,200 kW;  
motor speed 350/750 min<sup>-1</sup>.

## Bearing selection, dimensioning

Radial loads and thrust loads are accommodated separately: the radial loads by cylindrical roller bearings, the thrust loads by angular contact ball bearings and four point bearings. Cylindrical roller bearings offer the best radial load carrying capacity in a limited mounting space, thus keeping the distance between the gear shafts to a minimum. One decisive factor in the selection of the bearing size is the diameter of the individual gear shafts determined in the strength calculation. The two largest cylindrical roller bearings of the gear are situated on the cogging wheel side and have the following dimensions: 750 x 1,000 x 250 mm. Axial location of the four gear shafts is provided by one four point bearing each which are double direction angular contact ball bearings.

Compared to two angular contact ball bearings, a four point bearing offers the advantage of smaller width and, compared to a deep groove ball bearing, the advantage of smaller *axial clearance* and higher thrust carrying capacity. The use of four point bearings is, however, limited to applications where the thrust load is not constantly reversing. The bevel gear shafts feature the smallest possible *axial clearance* to ensure perfect meshing of the spiral-toothed gears. This is achieved by one duplex pair of angular contact ball bearings each on the pinion shaft and on the bevel shaft. They also accommodate the thrust load whereas the radial load is taken up by cylindrical roller bearings.

## Machining tolerances

Cylindrical roller bearings: Shaft to p6; housing to H6/H7.

Four point bearings and angular contact ball bearings: Shaft to f6; housing to D10.

The outer rings of the four point bearings and angular contact ball bearings are *fitted* into the housing with clearance to relieve them of radial loads; thus, they accommodate only thrust loads.

## Lubrication

Circulating *oil* lubrication. The bearings and gears share the same lubrication system. The *oil* is directly supplied to the bearings via an *oil* filter which prevents contamination of the bearings by particles abraded from the gears.

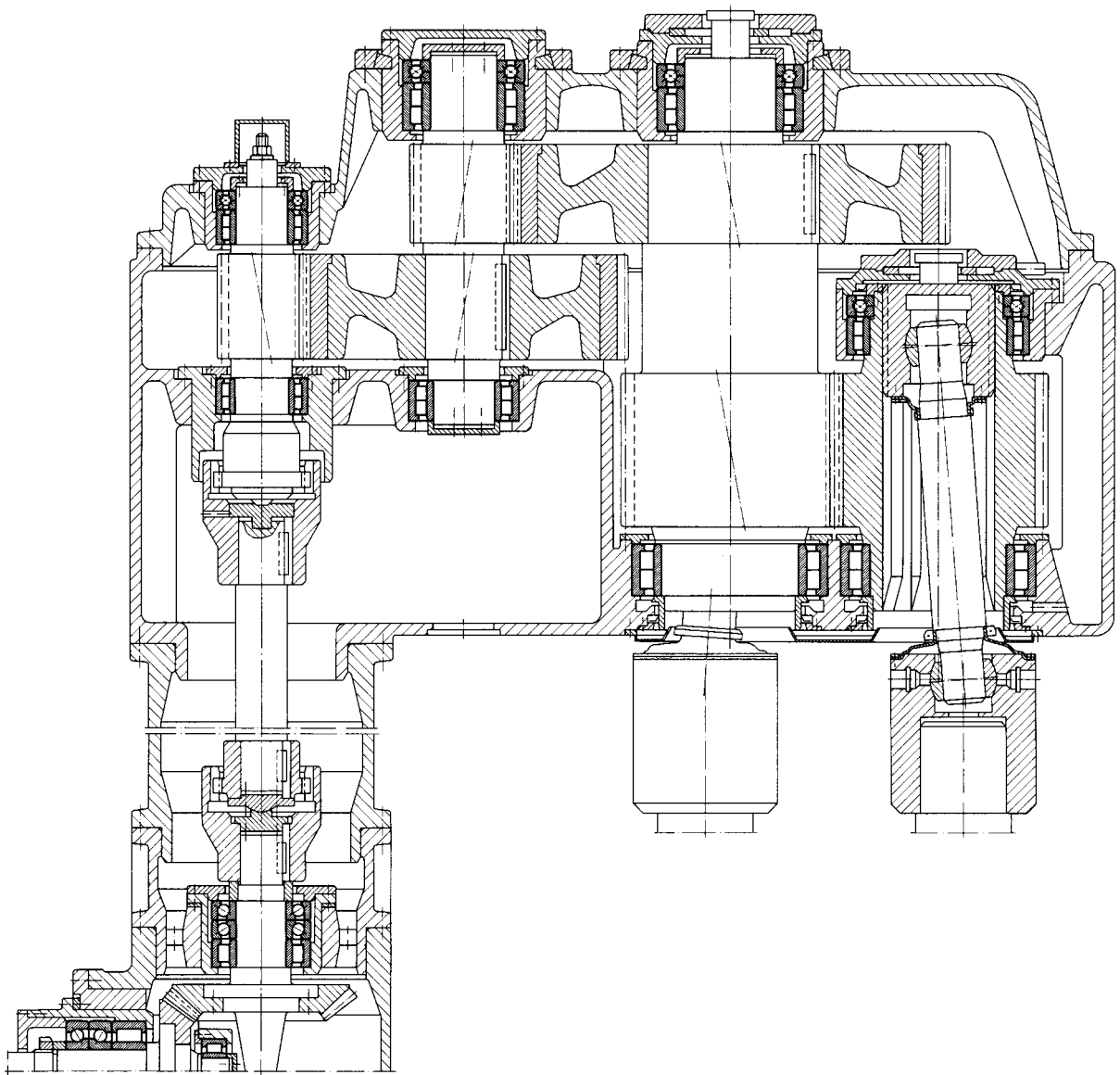

107: Combined reduction and cogging wheel gear of a billet mill

# 108 Work rolls of a section mill

The roll stand frames expand under the influence of high rolling loads, which can have a negative effect on the quality of the rolled material. This is usually prevented by means of elaborate roll adjustment mechanisms. Another way to compensate for the negative effect of the material's elasticity is to hydraulically preload the chocks which support the rolls and their bearing mountings against each other via the roll stands (see schematic drawing).

9 of the 13 in-line stands of a section mill are fitted with such hydraulically preloaded chocks. Five of the nine preloaded stands can also operate as universal stands. For this purpose they are equipped with two vertically arranged roll sets.

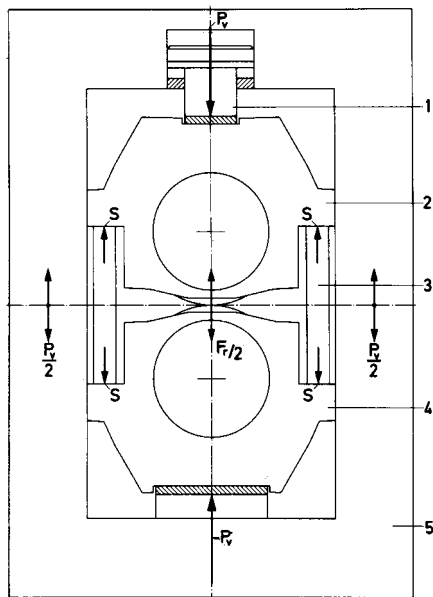

- 1 Hydraulic piston
- 2 Upper chock
- 3 Piston ram
- 4 Lower chock
- 5 Frame

## Roll neck mountings

The horizontal rolls are supported by multi-row cylindrical roller bearings and tapered roller bearings. The cylindrical roller bearings at the drive end compensate for the length variations caused by heat expansion. Compensation of length variations through the chock axially floating in the stand at the drive end is not possible with preloaded chocks.

The horizontal rolls in the roughing stands, which are loaded with 3,150 kN, are supported in four-row cylindrical roller bearings and four-row tapered roller bearings of 355.6 x 257.2 x 323.8 mm (fig. a). The bearings have a loose *fit* on the roll neck ( $e7$ ), which simplifies mounting.

No loose *fit* can be provided in those stands where section steels are finish-rolled as the required quality can only be achieved with accurately guided rolls. For this reason cylindrical roller bearings and tapered roller bearings with a tapered bore were selected and press-fitted onto the tapered roll neck. The hydraulic method used simplifies mounting and dismantling. Due to the lower rolling load (2,550 kN), the horizontal rolls in this case are supported by double-row cylindrical roller bearings and tapered roller bearings of 220.1 x 336.6 x 244.5 mm (fig. b).

The vertical rolls are each supported by a tapered roller bearing pair (dimensions 165.1 x 336.6 x 194.2 mm) in *O* arrangement (fig. a). The bearings sit directly on the rolls. As the rolling stock enters, the vertical rolls and their bearings are accelerated to operating speed very quickly. The tapered roller bearings are preloaded to ensure that the *rolling elements* always maintain contact with the raceways at these speeds. This is achieved by matching the tolerances of the bearings and bearing seats in such a way that the bearings after mounting have the right preload without any fitting work.

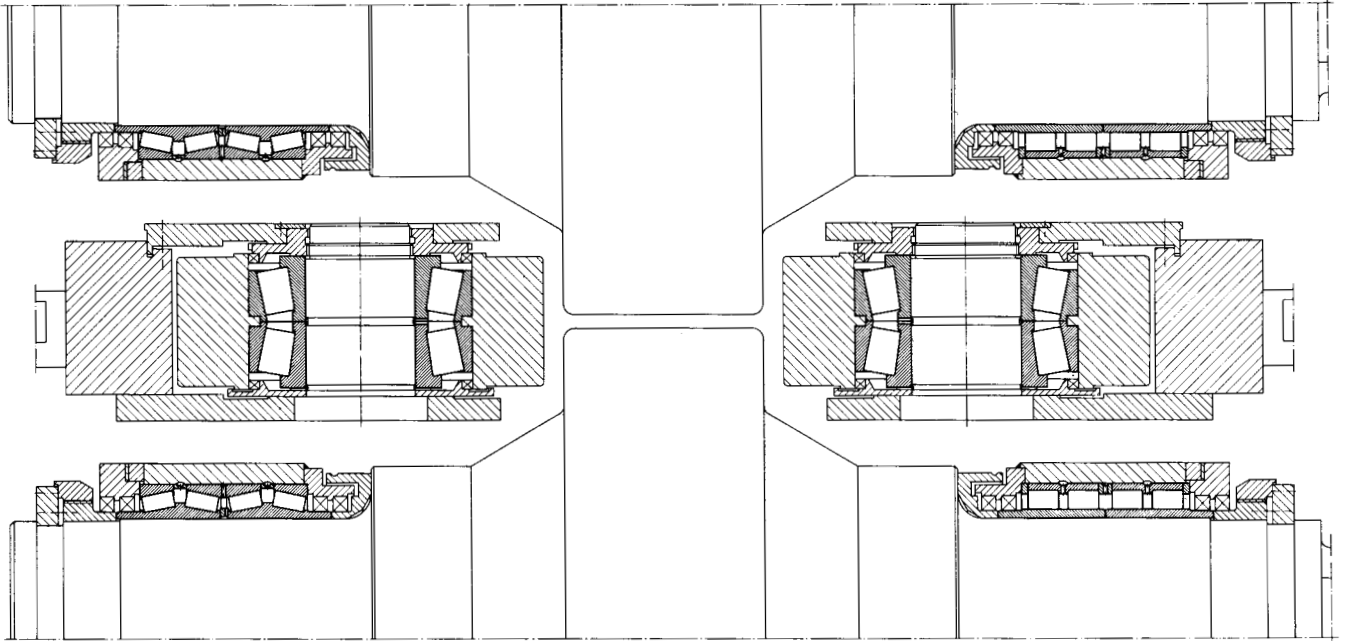

108a: Bearing mounting of horizontal rolls in the preloaded roughing stands and bearing mounting of the vertical rolls

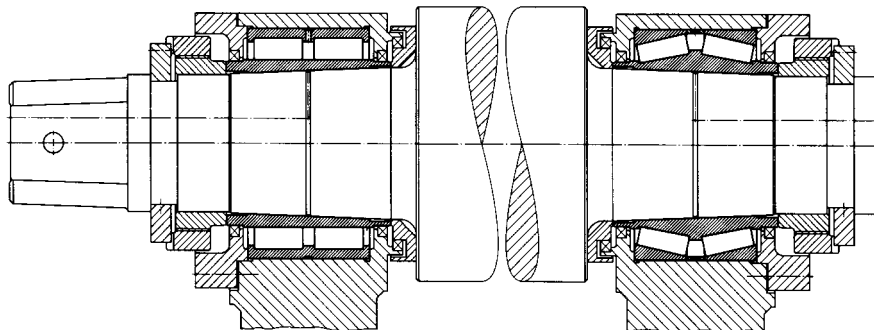

108b: Bearing mounting of horizontal rolls for stands in which section steel is finish-rolled

---

# 109 Two-high rolls of a dressing stand for copper and brass bands

---

On this dressing stand copper and brass bands with widths between 500 and 1,050 mm are rolled. The maximum initial thickness is 4 mm, and the minimum final thickness is 0.2 mm.

"Counterbending" is one special feature of this stand. The rolling forces cause an elastic deflection of the rolls. This deflection is hydraulically compensated for by counterbending forces. The counterbending forces are applied to the roll necks on both sides and outside the roll neck mounting via spherical roller bearings. This counterbending ensures a uniform band thickness over the entire band width.

## Operating data

Two-high roll diameter 690/650 mm; roll body length 1,150 mm; maximum rolling speed 230 m/min; maximum rolling force 8,000 kN; maximum counterbending force 1,300 kN per roll neck.

## Counterbending bearings

The counterbending forces are applied via spherical roller bearings FAG 24068B.MB.  
Machining tolerances: roll neck to e7, housing to H6.

## Accommodation of radial loads

One four-row cylindrical roller bearing FAG 547961 (dimensions 445 x 600 x 435 mm) is mounted at each end. The cylindrical roller bearings are fitted with pin-type *cages* consisting of two side washers to which the pins passing through the rollers are fastened. Grooves in the inner ring faces facilitate dismounting.

Machining tolerances:

roll neck +0.160 / +0.200 mm, chock H6.

## Accommodation of thrust loads

At the operating end the axial forces are accommodated by two *O arranged* angular contact ball bearings FAG 507227.N10BA (dimensions 400 x 600 x 90 mm).

At the drive end the chock is located on the roll neck by a deep groove ball bearing FAG 6080M.C3.

Machining tolerances: roll neck to f6, outer ring radially relieved.

## Lubrication

The cylindrical roller bearings, like the other bearings, are lubricated with a lithium soap base *grease* with *EP additives*. They can easily be lubricated through lubricating holes and lubricating grooves in the outer rings and spacers.

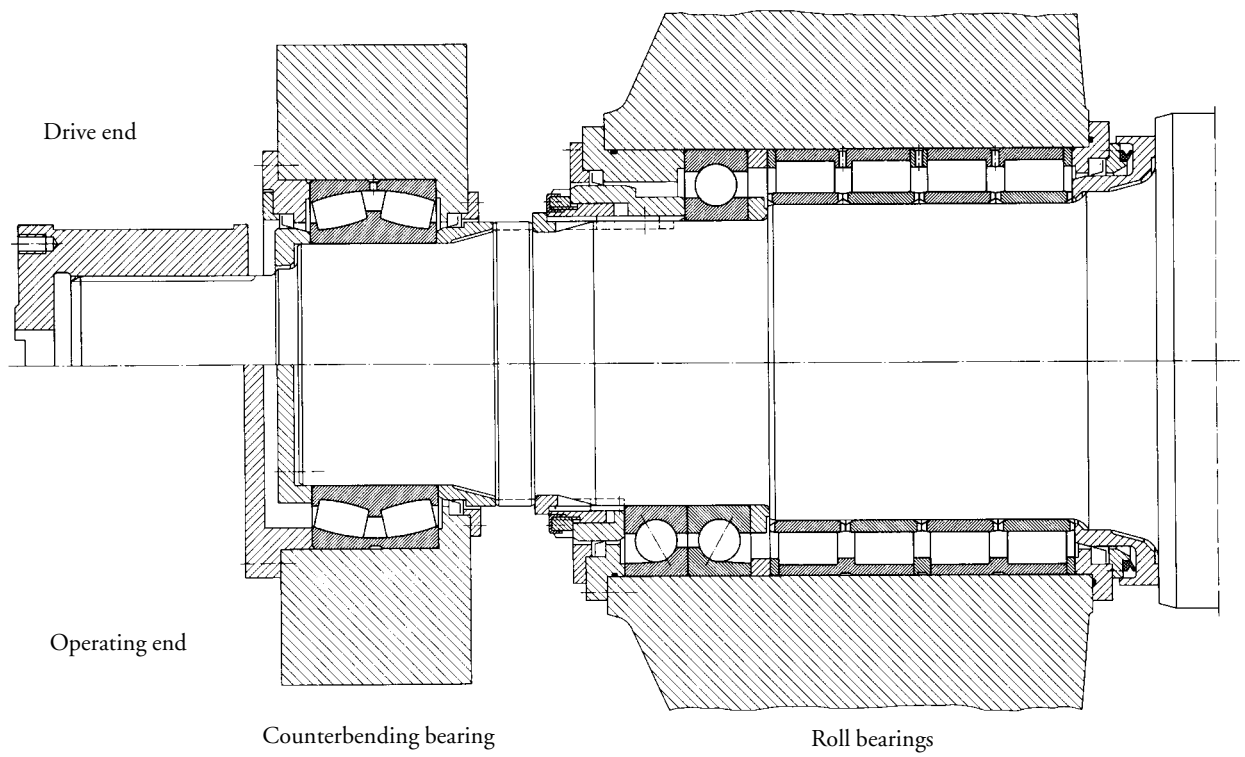

# 110 Straightening rolls of a rail straightener

Rails for railway track systems or for craneways are hot rolled in rolling mills. After rolling the rails cool down on cooling beds but not uniformly, resulting in warping. Afterwards they have to be straightened in rail straighteners between horizontal and vertical rolls.

The straightening plant consists of two machines one installed behind the other. In the first machine the rails run through horizontally arranged rolls, in the second machine through vertically arranged rolls. Thus the rails are straightened in both planes after having passed through the two machines.

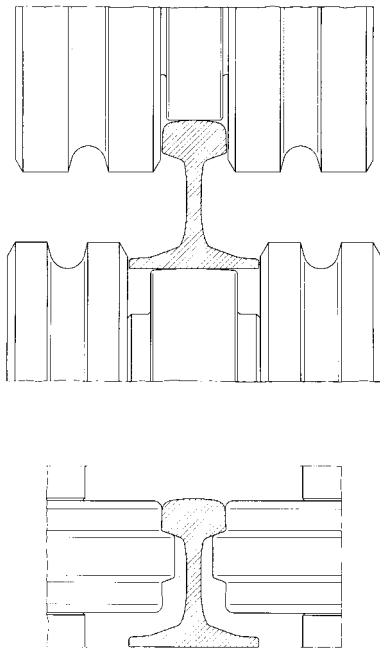

Each machine features nine straightening rolls, four of which are being driven. The straightening rolls with diameters of 600...1,200 mm form an overhung arrangement in order to allow easy replacement.

## Demands on the bearing assembly

The mounting space for the bearings is dictated by the distance of the straightening rolls. In this mounting space bearings are accommodated which have such a high load carrying capacity as to allow for reasonable running times.

The bearing assembly for the straightening rolls must have maximum rigidity since this determines the accuracy of the rolled stock.

The roll position must be adjustable to the position of the rolled stock. For this reason the bearing assembly had to be designed such as to allow for a change of the position of the straightening rolls by  $\pm 50$  mm in the axial direction.

## Horizontal straightening rolls

The maximum rolling force at the horizontal rolls is 4,200 kN. Depending on the type of rolled stock, thrust loads of up to 2,000 kN have to be accommodated.

Speeds range from two to 60  $\text{min}^{-1}$ .

Double-row cylindrical roller bearings have been provided to accommodate the radial forces and because of their high load carrying capacity. The higher loaded cylindrical roller bearing, which is situated directly beside the roll, was especially developed for supporting the straightening rolls (dimensions 530 x 780 x 285/475 mm). The less loaded cylindrical roller bearing has the dimensions 300 x 460 x 180 mm.

The cylindrical roller bearings are fitted with bored rollers which are evenly spaced by pins and *cage* side washers.

As this design allows the distance between the rollers to be indefinitely small, the largest possible number of rollers can be fitted and, adapted to the mounting space, the highest possible load carrying capacity can be obtained for the bearing.

The thrust loads are accommodated by two spherical roller thrust bearings FAG 29448E.MB (dimensions 240 x 440 x 122 mm). They are spring-*adjusted*.

When positioning the straightening rolls, the bearings must be able to compensate for axial displacements by up to  $\pm 50$  mm. This is made possible by providing an extended inner ring for the cylindrical roller bearing located beside the straightening roll. The inner ring width is such that the lips of the two *seals* always slide safely on the inner ring even with maximum axial displacement.

The second cylindrical roller bearing is seated, together with the two spherical roller thrust bearings, in a sleeve which is axially displaceable within the hollow cylinder. The position of the straightening rolls relative to the rolled stock is adjusted by means of a ball screw.

## Vertical straightening rolls

The vertical straightening roll bearing arrangement is in principle identical to that of the horizontal straightening rolls. Due to the lower straightening loads, however, smaller bearings can be mounted.

*Radial bearings:* one axially displaceable double-row cylindrical roller bearing (dimensions 340 x 520 x 200/305 mm) and one single-row cylindrical roller bearing FAG NU2244M.C3 (dimensions 220 x 400 x 108 mm).

*Thrust bearings:* two spherical roller thrust bearings FAG 29432E (dimensions 160 x 320 x 95 mm).

---

## Lubrication, sealing

In spite of the high loads and the low speeds it would be possible to lubricate the cylindrical roller bearings with *grease*. However, the spherical roller thrust bearings must be *oil*-lubricated. Therefore, all bearings are supplied with *oil* by means of a central lubricating

system. The *oil* flow rate per straightening roll unit is about 10 l/min.

At the spherical roller thrust bearing end the unit is closed by a cover. At the shaft opening in the direction of the straightening roll two laterally reversed, *grease*-lubricated *seal* rings prevent oil escape and penetration of contaminants into the bearings.

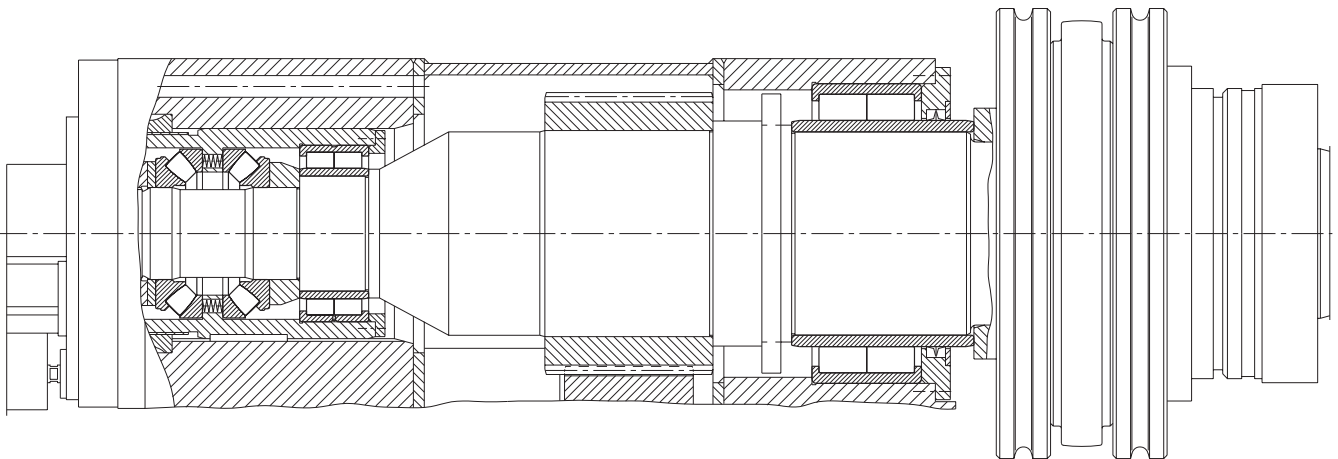

---

# 111 Disk plough

---

In a disk plough the usual stationary blades are replaced by revolving disks fitted to the plough frame. The working width of the plough is determined by the number of disks.

## Bearing selection

During ploughing both radial and axial loads are imposed on the bearings. Bearing loads depend on soil conditions and cannot, therefore, be exactly determined. For safety reasons roller bearings with the maximum possible load carrying capacity are used. One tapered roller bearing FAG 30210A (T3DB050 \*) and one FAG 30306A (T2FB030 \*) are installed in *O* arrangement and *adjusted*, via the cone of the smaller bearing, with zero clearance. This cone must, therefore, be able to slide on the journal.

\*) Designation to DIN ISO 355

## Machining tolerances

on the journal:  
– j6 for the smaller bearing,  
– k6 for the larger bearing;  
in the housing: N7.

## Lubrication, sealing

*Grease* lubrication (FAG rolling bearing grease *Arcanol* L186V). The bearings are adequately protected from dirt and atmospheric influences by means spring steel *seals* and an additional labyrinth seal.

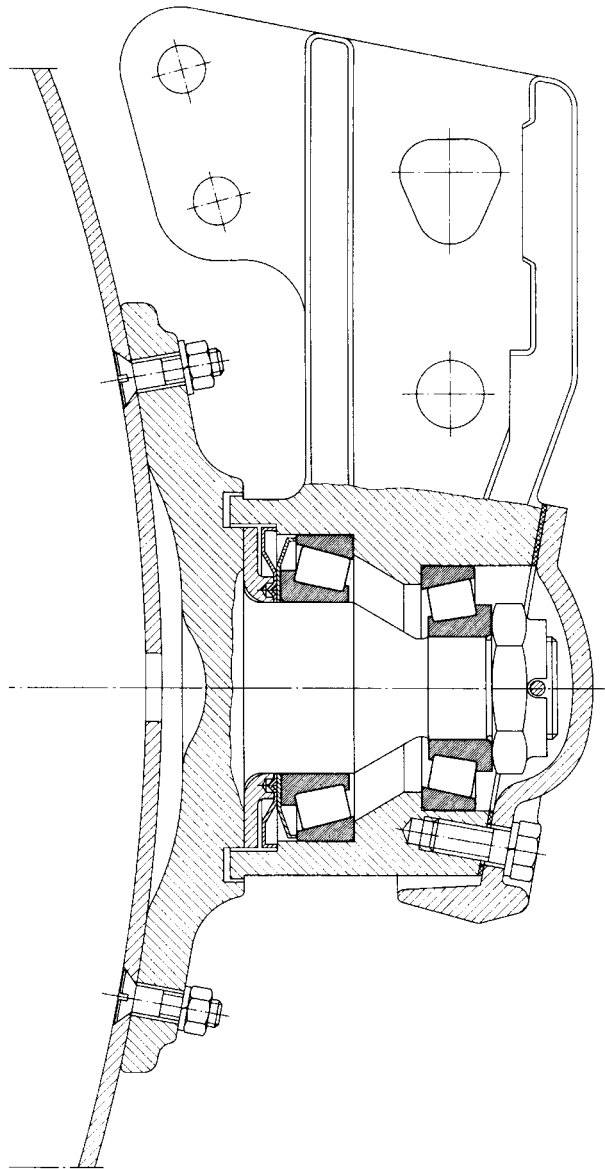

111: Disk plough

# 112 Plane sifter

Sifters are used in flour mills to segregate the different constituents (e.g. groats, grits, flour). The plane sifter described in this example consists of four sections, each comprising 12 sieves fastened to a frame. An eccentric shaft induces circular vibrations in the frame-sieve assembly.

## Operating data

Starting power 1.1 kW, operating power 0.22 kW; speed 220...230 min<sup>-1</sup>; total weight of balancing masses 5.5 kN; distance between centre of gravity of balancing masses and axis of rotation 250 mm; total weight of frame and sieves plus material to be sifted 20...25 kN.

## Bearing selection

The drive shaft with the balancing masses is suspended from the top bearing. The supporting bearing must be *self-aligning* in order to avoid preloading. The bearings mounted are a self-aligning ball bearing FAG 1213 (65 x 120 x 23 mm) and a thrust ball bearing FAG 53214 (70 x 105 x 28,8 mm). The spherical housing washer FAG U214 compensates for misalignment during mounting.

The *thrust bearing* has to accommodate the weight of the drive shaft and balancing masses. The eccentric shaft of the sifter frame is supported by a spherical roller bearing FAG 22320E.T41A. This bearing accommodates the high centrifugal forces resulting from the circular throw of the sifter frame and sieves. Sleeve B is a loose fit on the eccentric shaft; thus the spherical roller bearing is axially displaceable together with the sleeve and cannot be submitted to detrimental axial preloading.

## Machining tolerances

- Self-aligning ball bearing.  
Hollow shaft to k6, pulley bore to J6.
- Spherical roller bearing.  
Sleeve to k6, frame housing bore to K6.

## Lubrication

The ball bearings at the top mounting run in an *oil* bath. The spherical roller bearing at the bottom mounting is lubricated by circulating *oil*. A thread cut in the eccentric shaft feeds the oil upward through sleeve B. From the top the oil passes through the spherical roller bearing and back into the oil bath.

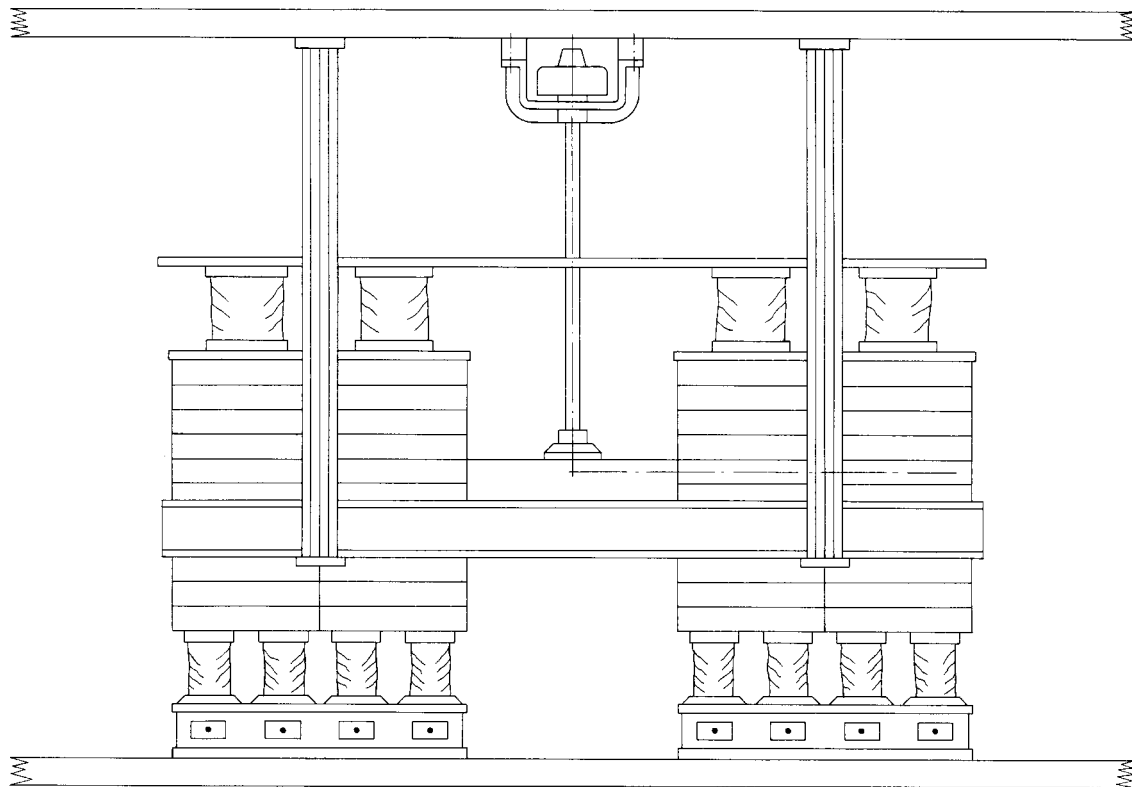

Layout of a plane sifter

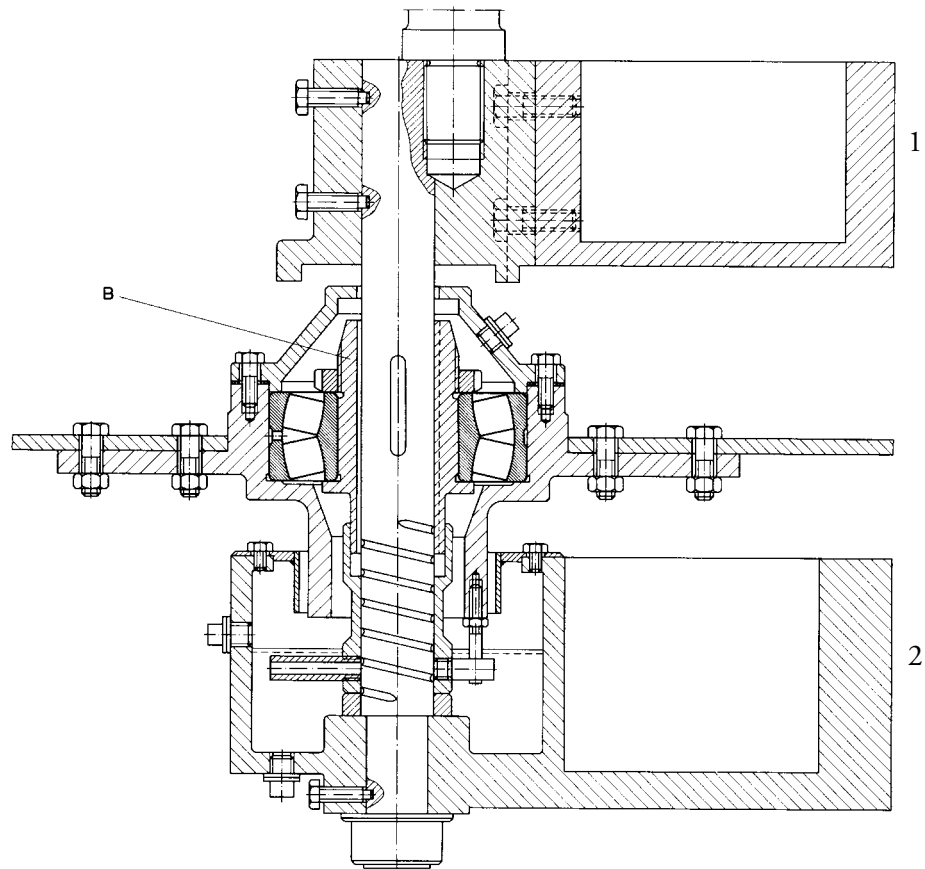
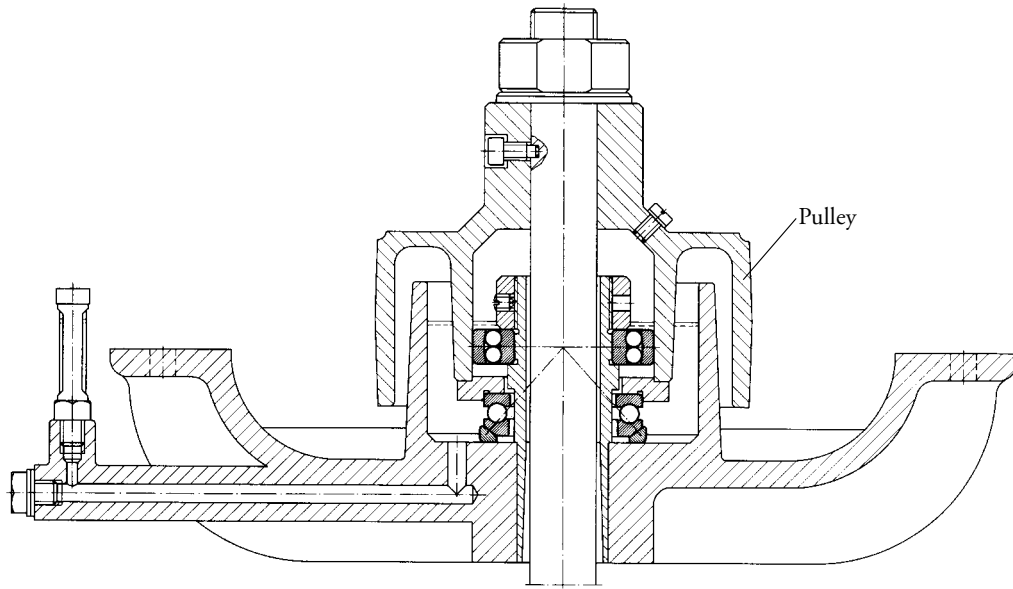

Printing quality is created in the heart of a printing press, the printing group with its main cylinders. Plate cylinders, blanket cylinders and impression cylinders are, therefore, guided in rolling bearings which are particularly low in friction and which have a high degree of running accuracy and radial rigidity.

FAG has designed a number of highly efficient *locating/floating bearing arrangements* for the main cylinder bearings ranging from solutions with cylindrical roller bearings, tapered roller bearing pairs and spherical roller bearings to triple-ring eccentric bearing units.

---

# 113

## Impression cylinders of a newspaper rotary printing press

---

Depending on the specific application, a variety of solutions can be adopted for supporting impression cylinders in a newspaper rotary printing press. Often the *floating bearing* at the operating end is a cylindrical roller bearing and the *locating bearing* arrangement at the drive end consists of a spherical roller bearing or a tapered roller bearing pair. The *floating bearing* accommodates only radial loads whereas the *locating bearing* takes up both radial and thrust loads. Differing spring rates (elastic deformation of *rolling elements* and raceways) and loads acting on the bearings can result in a differing vibration behaviour at each end of the cylinders (negative effect on printing quality).

### Operating data

The forces acting on impression cylinders in rotary printing presses are safely accommodated by FAG rolling bearings. In newspaper rotary printing presses a paper web, which may be up to 1,400 mm wide, is fed into the machine via automatic wheel stands at a speed of 9.81 m/s. At a maximum speed of the impression cylinders of 35,000 revolutions per hour and double production, the rotary printing press produces 7,000 copies per hour with a volume of up to 80 pages.

The circumference and width of the impression cylinders are adapted to the required newspaper sizes (e.g. cylinder diameter 325 mm, speed 583.3 min<sup>-1</sup>, mass 1,100 kg, operating temperature 50...60 °C, average time in operation 7,000 hours per year).

### Bearing selection

To rule out differences in vibration behaviour FAG has separated the accommodation of the radial and axial loads from the impression cylinders.

At each end the radial loads are accommodated by a double-row cylindrical roller bearing FAG NN3024ASK.M.SP. A deep groove ball bearing pair 2 x FAG 16024.C3 provides axial guidance for the impression cylinder. The outer rings are radially relieved so that the ball bearings exclusively accommodate axial guiding forces in both directions. By providing identical bearing arrangements on both sides of the impression cylinder identical spring rates are obtained.

The separation of radial and thrust loads means that the radially supporting bearings are symmetrically loaded. This produces a uniform vibration behaviour on both sides of the impression cylinder.

### Bearing clearance and adjustment

The low-friction *precision bearings* are accommodated on both sides by eccentric bushes which serve to control the "impression on" and "impression off" movements of the different impression cylinders independently of each other. This requires a high guiding accuracy and a minimal *radial clearance*. Heat development within the bearing is low, which helps achieve the required optimal guiding accuracy. The bearing clearance of 0...10 µm is adjusted via the tapered bearing seat. The temperature-related length compensation takes place in the cylindrical roller bearings between the rollers and the outer ring raceway so that the outer ring can be *fitted* tightly in spite of the *point load*.

The deep groove ball bearings are fitted in *X arrangement* with zero clearance (Technical Specification N13CA). The C3 *radial clearance* ensures a *contact angle* which is favourable for accommodating the axial guiding forces.

### Machining tolerances

#### Cylindrical roller bearings

Inner ring: *Circumferential load*; interference fit on tapered shaft 1:12.

Outer ring: *Point load*; housing bore to K6.

#### Deep groove ball bearings

Shaft to j6 (k6),  
outer ring radially relieved in the housing.

### Lubrication, sealing

The bearings are automatically supplied with lubricant. Through a circumferential groove and lubricating holes in the outer ring the lubricant is fed directly into the bearings. At the operator end the supply lines are usually connected to a central *grease* lubrication system. V-ring *seals* prevent both *grease* escape and dirt ingress. The bearings at the drive end are supplied with *oil* from the transmission oil lubrication system via feed ducts. The *oil* first flows through the cylindrical roller bearing and then through the deep groove ball bearing pair. At the cylinder end a pressure-relieved shaft *seal* retains the *oil* in the lubricating system.

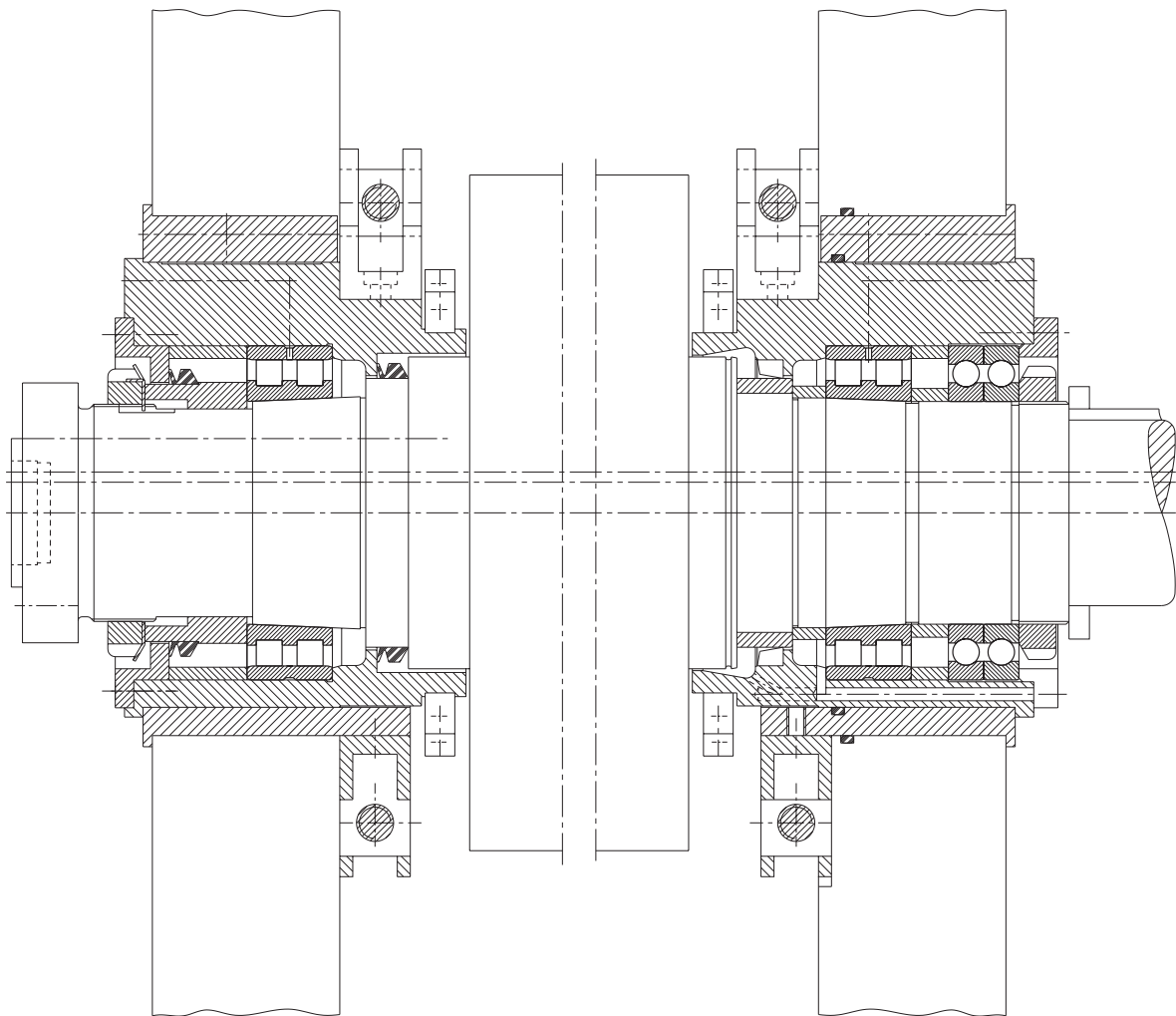

113: Impression cylinder of a KBA Commander newspaper rotary printing press

# 114 Blanket cylinder of a sheet-fed offset press

To date it was common practice to integrate cylindrical roller bearings, needle roller bearings or other designs in a sliding bearing supported sleeve and to accurately fit this complete unit into an opening in the sidewall of the machine frame; this required an elaborate technology and was costly. Both the considerable cost and the risk of the sleeve getting jammed during the "impression on" and "impression off" movements of the blanket cylinder are eliminated by using a new triple-ring eccentric bearing unit. It offers the benefit of absolute zero clearance which is not possible with the conventional unit as the sleeve always requires some clearance. Another significant advantage is the adjustable preload which allows its radial rigidity to be considerably increased compared to bearings with clearance.

## Bearing arrangement

The FAG triple-ring eccentric bearing units (*floating bearings*) are available both with a cylindrical and with a tapered bore. The ready-to-mount unit is based on an NN cylindrical roller bearing design which is used as a low-friction *precision bearing* in machine tools, and a double-row needle roller bearing which guides the eccentric ring. Axial guidance of the cylinder is provided by angular contact ball bearings (FAG 7207B) in *X arrangement*, or by a thrust ball bearing.

## Operating data

Roll weight; press-on force; nominal speed

## Bearing dimensioning

An *index of dynamic stressing*  $f_L$  of 4...4.5 would be ideal. This corresponds to a *nominal life*  $L_h$  of 50,000 – 80,000 hours. Under the given conditions the bearings are adequately dimensioned so that an *adjusted rating life calculation* is not required.

## Machining tolerances

The inner rings are subjected to *circumferential load*. A tight *fit* is obtained by machining the cylinder journal to k4 (k5). With a tapered bearing seat, an interference fit is also obtained by axial displacement. The outer ring is mounted with a K5 or K6 *fit* or reduced tolerances (with a slight interference).

## Lubrication, sealing

The eccentric units can be lubricated both with *grease* and with *oil*. Thanks to the favourable ambient conditions, the lubricant is only very slightly stressed so that long *grease relubrication intervals* and thus a long *service life* are possible. A non-rubbing gap-type *seal* prevents grease escape. With *oil lubrication*, the *oil* flows to the bearing rollers through feed ducts. Via collecting grooves and return holes the *oil* returns to the *oil* circuit.

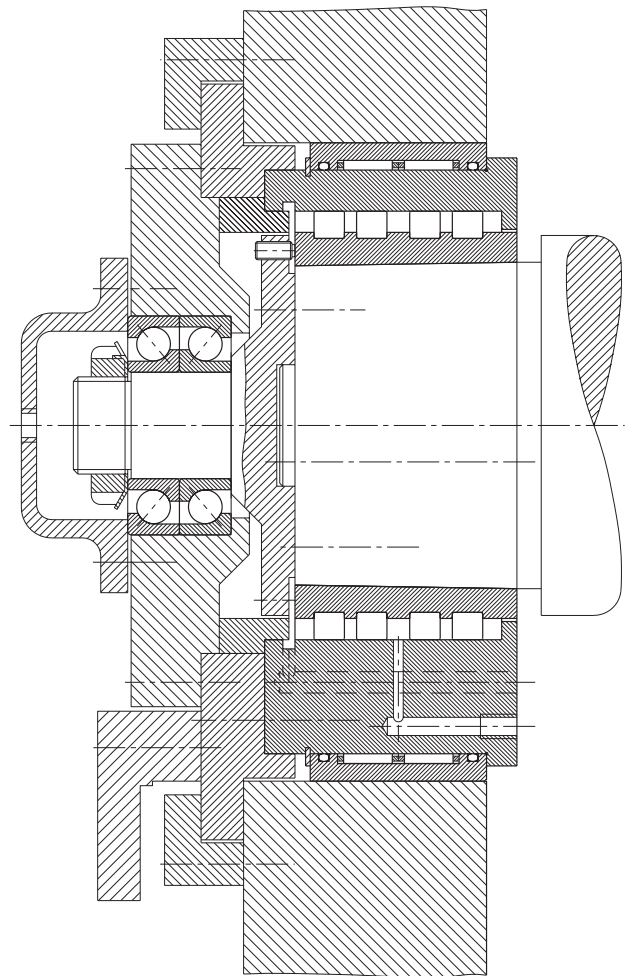

114: Triple ring bearing for a blanket cylinder

# 115 Centrifugal pump

## Operating data

Input power 44 kW; delivery rate 24,000 l/min; delivery head 9 m; speed  $n = 1,450 \text{ min}^{-1}$ ; axial thrust 7.7 kN.

## Bearing selection, dimensioning

The impeller is overhung. The coupling end of the impeller shaft is fitted with a duplex pair of contact ball bearings FAG 7314B.TVP.UA mounted in *X arrangement*. The suffix UA identifies bearings which can be universally mounted in *tandem*, *O* and *X arrangement*. When mounted in *O* or *X arrangement*, if the shaft is machined to j5 and the housing to J6, the bearings have a slight *axial clearance*. The bearing pair acts as the *locating bearing* and accommodates the thrust  $F_a = 7.7 \text{ kN}$ . The radial load  $F_r$  is approx. 5.9 kN. Since  $F_a/F_r = 1.3 > e = 1.14$ , the *equivalent dynamic load*  $P$  of the bearing pair

$$P = 0.57 \cdot F_r + 0.93 \cdot F_a = 10.5 \text{ kN}$$

Thus the *index of dynamic stressing*

$$f_L = C/P \cdot f_n = 186/10.5 \cdot 0.284 = 5.03$$

The *nominal life* amounts to approximately 60,000 hours. The *speed factor* for ball bearings  $f_n = 0.284$  ( $n = 1,450 \text{ min}^{-1}$ ) and the *dynamic load rating* of the bearing pair

$$C = 1.625 \cdot C_{\text{individual bearing}} = 1.625 \cdot 114 = 186 \text{ kN.}$$

The impeller end of the shaft is fitted with a cylindrical roller bearing FAG NU314E.TVP2 acting as the *floating bearing*. This bearing supports a radial load of approximately 11 kN. Thus, the *index of dynamic stressing*

$$f_L = C/P \cdot f_n = 204/11 \cdot 0.322 = 5.97$$

corresponding to a *nominal rating life* of more than 100,000 hours.

With the *speed factor* for roller bearings  $f_n = 0.322$  ( $n = 1,450 \text{ min}^{-1}$ ), the *dynamic load rating* of the bearing  $C = 204 \text{ kN}$ .

The recommended  $f_L$  values for centrifugal pumps are 3 to 4.5. The bearings are, therefore, adequately dimensioned with regard to *fatigue life*. The *service life* is shorter if formation of condensation water in the bearings or penetration of contaminants is expected.

## Lubrication, sealing

*Oil bath lubrication*. The *oil level* should be no higher than the centre point of the lowest *rolling element*. The bearings are *sealed* by shaft seals. At the impeller end of the shaft a labyrinth provides extra *sealing protection*.

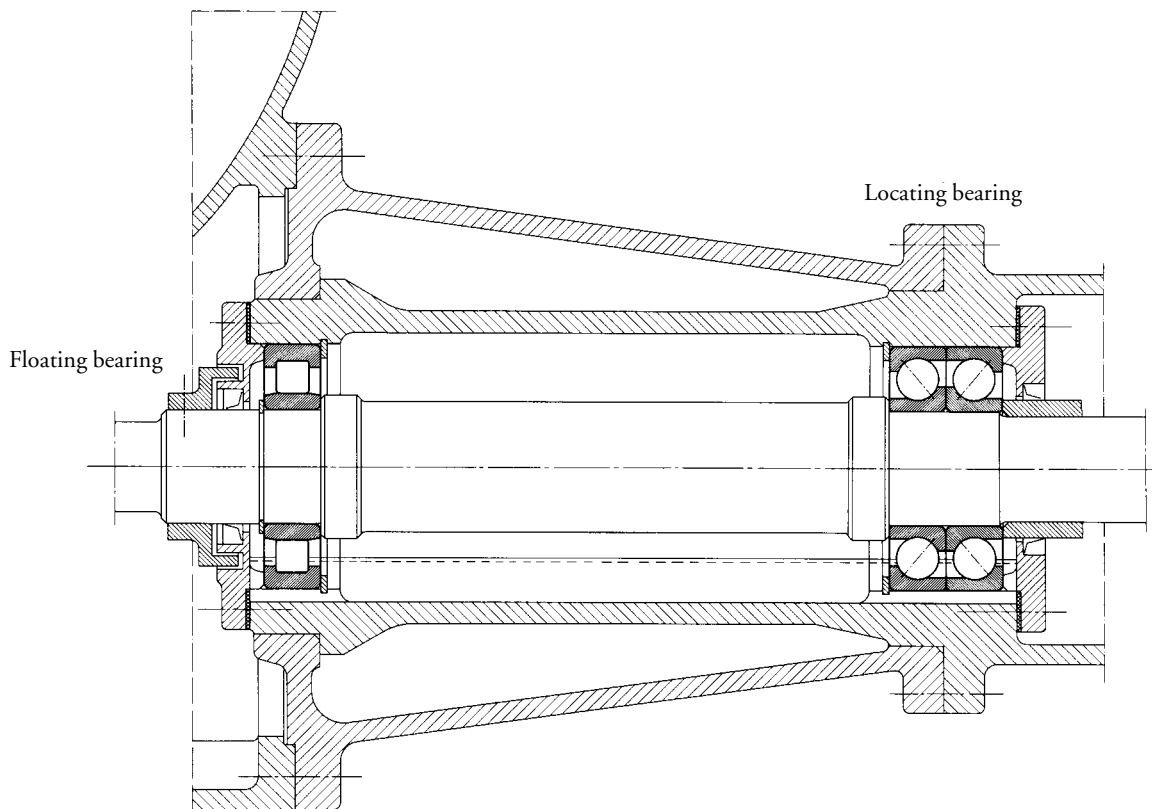

115: Centrifugal pump

# 116 Axial piston machine

Cylinder block A accommodates a number of pistons B symmetrically arranged about the rotational axis. Piston rods C transmit the rotation of drive shaft D to the cylinder block. They also produce the reciprocating motion of the pistons, provided that the rotational axis of cylinder block and drive shaft are at an angle to each other.

Fluid intake and discharge are controlled via two kidney-shaped openings E in pump housing F. Bore G establishes connection from each cylinder to openings E. During one rotation of the cylinder block, each bore sweeps once over the intake (suction) and discharge (pressure) openings. The discharge opening is subjected to high pressure. Consequently, the pistons are acted upon by a force. This force is carried by the piston rods to the drive shaft and from there to the drive shaft bearings.

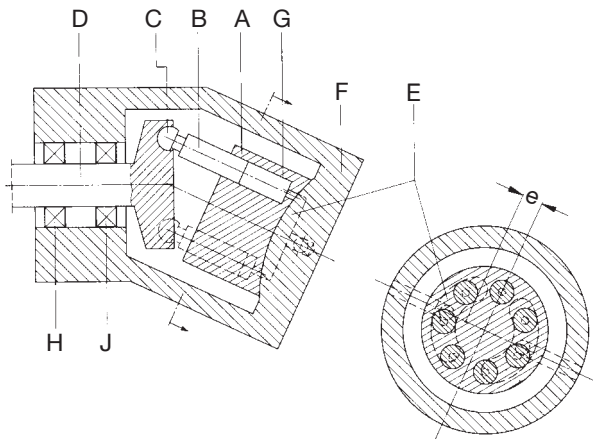

In axial piston machines only some of the pistons are pressurized (normally half of all pistons). The individual forces of the loaded pistons are combined to give a resultant load which acts eccentrically on the swash plate and/or drive flange.

## Operating data

Rated pressure  $p = 100 \text{ bar} = 10 \text{ N/mm}^2$ ; max. speed  $n_{\text{max}} = 3,000 \text{ min}^{-1}$ , operating speed  $n_{\text{nom}} = 1,800 \text{ min}^{-1}$ ; piston diameter  $d_K = 20 \text{ mm}$ , piston pitch circle = 59 mm, angle of inclination  $\alpha = 25^\circ$ , number of pistons  $z = 7$ ; distance between load line and rotational axis  $e = 19.3 \text{ mm}$ .

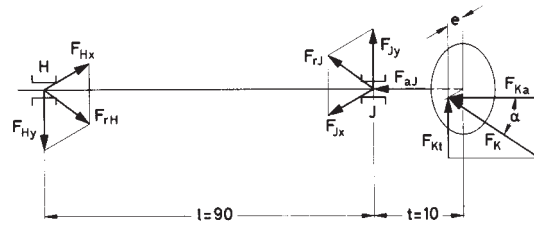

## Bearing selection

At relatively high speeds, bearings H and J have to accommodate the reactions from the calculated resultant load. The bearing mounting should be simple and compact.

These requirements are met by deep groove ball bearings and angular contact ball bearings. Bearing location H features a deep groove ball bearing FAG 6208, bearing location J two *universal* angular contact ball bearings FAG 7209B.TVP.UA in *tandem arrangement*. Suffix UA indicates that the bearings can be *universally* mounted in *tandem*, *O* or *X arrangement*.

## Bearing dimensioning

Assuming that half of the pistons are loaded, piston load

$$F_K = z/2 \cdot p \cdot d_K^2 \cdot \pi/4 = 3.5 \cdot 10 \cdot 400 \cdot 3.14/4 = 11,000 \text{ N} = 11 \text{ kN}$$

For determination of the bearing loads the piston load  $F_K$  is resolved into tangential component  $F_{Kt}$  and thrust load component  $F_{Ka}$ :

$$F_{Kt} = F_K \cdot \sin \alpha = 11 \cdot 0.4226 = 4.65 \text{ kN}$$

$$F_{Ka} = F_K \cdot \cos \alpha = 11 \cdot 0.906 = 9.97 \text{ kN}$$

The two components of the piston load produce radial loads normal to each other at the bearing locations. The following bearing loads can be calculated by means of the load diagram:

### Bearing location J

$$F_{Jx} = F_{Ka} \cdot e/l = 9.97 \cdot 19.3/90 = 2.14 \text{ kN}$$

$$F_{Jy} = F_{Kt} \cdot (l + t)/l = 4.65 \cdot (90 + 10)/90 = 5.17 \text{ kN}$$

$$F_{rj} = \sqrt{F_{Jx}^2 + F_{Jy}^2} = \sqrt{4.58 + 26.73} = 5.59 \text{ kN}$$

In addition to this radial load  $F_{rj}$ , bearing location J accommodates the thrust load component of the piston load:

$$F_{aj} = F_{Ka} = 9.97 \text{ kN}$$

Thus, the *equivalent dynamic load* with  $F_a/F_r = 9.97/5.59 > e = 1.14$  and  $X = 0.35$  and  $Y = 0.57$ .

$$P = 0.35 \cdot F_{rj} + 0.57 \cdot F_{aj} = 0.35 \cdot 5.59 + 0.57 \cdot 9.97 = 7.64 \text{ kN}$$

With the *dynamic load rating*  $C = 72 \text{ kN}$  and the *speed factor*  $f_n = 0.265$  ( $n = 1,800 \text{ min}^{-1}$ ) the *index of dynamic stressing*

$$f_L = C/P \cdot f_n = 72/7.64 \cdot 0.265 = 2.5$$

Here the *load rating*  $C$  of the bearing pair is taken as double the *load rating* of a single bearing.

#### **Bearing location H**

$$F_{Hx} = F_{Ka} \cdot e/l = 9.97 \cdot 19.3/90 = 2.14 \text{ kN}$$

$$F_{Hy} = F_{Kt} \cdot t/l = 4.65 \cdot 10/90 = 0.52 \text{ kN}$$

$$F_{rH} = \sqrt{F_{Hx}^2 + F_{Hy}^2} = \sqrt{4.58 + 0.27} = 2.2 \text{ kN}$$

The *equivalent dynamic load* for the deep groove ball bearing equals the radial load:

$$P = F_{rH} = 2.2 \text{ kN}$$

With the *dynamic load rating*  $C = 29 \text{ kN}$  and the *speed factor*  $f_n = 0.265$  ( $n = 1,800 \text{ min}^{-1}$ ) the *index of dynamic stressing*

$$f_L = C/P \cdot f_n = 29/2.2 \cdot 0.265 = 3.49$$

The index  $f_L$  for axial piston machines selected is between 1 and 2.5; thus the bearing mounting is adequately dimensioned. Loads occurring with gearwheel drive or V-belt drive are not taken into account in this example.

#### **Machining tolerances**

Seat	Deep groove ball bearing	Angular contact ball bearing
Shaft	j5	k5
Housing	H6	J6

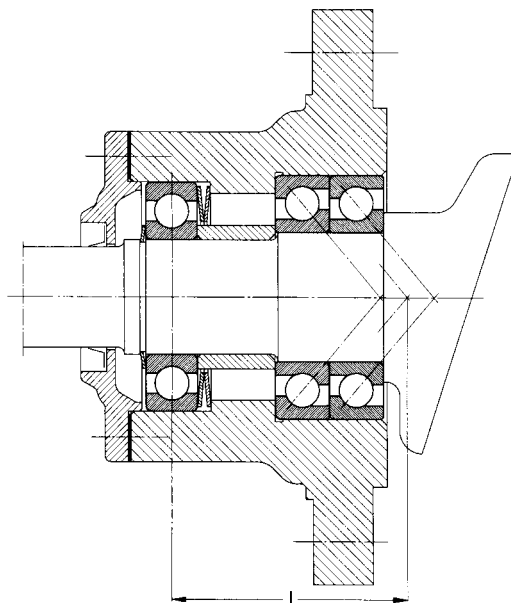

116: Drive flange of an axial piston machine

# 117 Axial piston machine

## Operating data

Rated pressure  $p = 150$  bar; maximum speed  $n_{\max} = 3,000 \text{ min}^{-1}$ , operating speed  $n_{\text{nom}} = 1,500 \text{ min}^{-1}$ ; piston diameter  $d_K = 25$  mm, piston pitch circle = 73.5 mm; angle of inclination  $\alpha = 25^\circ$ ; number of pistons  $z = 7$ ; distance between load line and rotational axis  $e = 24$  mm.

## Bearing selection, dimensioning

The bearing loads are determined as in example 116.

Bearing location H: Deep groove ball bearing  
FAG 6311  
Index of dynamic stressing  $f_L = 2.98$

Bearing location J: Angular contact ball bearing  
FAG 7311.TVP  
Index of dynamic stressing  $f_L = 1.19$

In examples 116 and 117 the axial load is accommodated by angular contact ball bearings mounted near the drive flange end. *Counter guidance* is provided by a deep groove ball bearing.

To minimize shaft tilting due to the *radial clearance* of the deep groove ball bearing, Belleville spring washers keep the bearing under light axial preload, thus ensuring zero clearance. A comparison of the  $f_L$  values determined for the two pumps shows that the pump described in example 117 is designed for only a short operating life (*rating fatigue life* 850 h). This life span is, however, sufficient for many applications (e.g. dump trucks).

## Lubrication, sealing

The bearings are lubricated by leakage *oil* from the pump. A shaft *seal* is satisfactory.

## Machining tolerances

Seat	Deep groove ball bearing	Angular contact ball bearing
Shaft	h6	j5
Housing	J6	J6

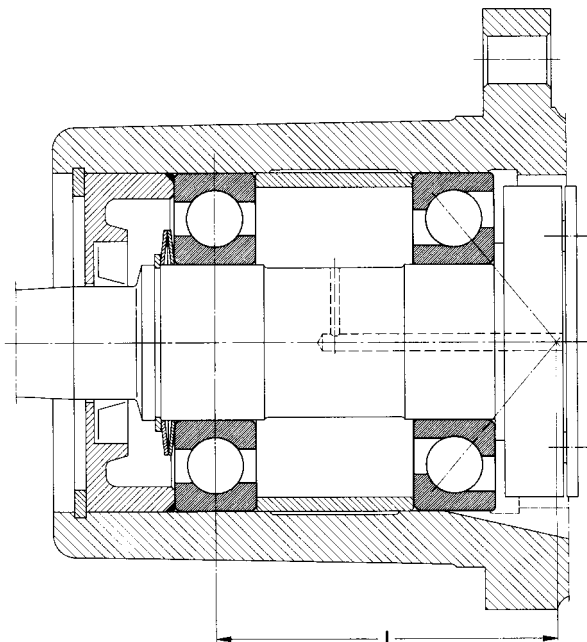

117: Drive flange of an axial piston machine

# 118 Exhauster

The exhauster is of the double-flow type; rotor weight 22 kN; speed 1,200 min<sup>-1</sup>; exhaust gas temperature approx. 180 °C.

## Bearing selection, dimensioning

The use of plummer blocks for mounting the rotor shaft is simple and economical. The shaft diameter is dictated by strength considerations, and determines plummer block and bearing size.

The shaft is mounted on spherical roller bearings FAG 22226E.C3 fitted in housings FAG LOE226BF and FAG LOE226AL. Due to the exhaust gas temperature of +180 °C and the relatively high exhauster speed, the bearings feature an increased *radial clearance* C3. This prevents the bearings from running under preload when there are major temperature differences between inner and outer ring. In addition, cooling discs are required to limit the bearing temperature. The plummer block at the drive end is designed as the *locating bearing* with a shaft opening (design BF), and that at the opposite end as the *floating bearing* with end cap (design AL).

With the specified operating data the calculated *index of dynamic stressing*  $f_L \approx 10$ ; an  $f_L$  value of 4...5 (corresponding to 55,000...100,000 h) would be adequate. Thus, the bearings are very safely dimensioned with regard to *fatigue life*. However, premature *wear* can be caused by slippage, ending the actual *service life* of the bearings before the *calculated fatigue life* has been reached.

The plummer blocks are made of grey cast iron. The housing bodies are split to simplify mounting.

## Machining tolerances

Shaft to m6; housing to G6.

## Lubrication, sealing

The LOE housings feature an *oil* bath. A ring oiler supplies the bearings with *oil*. The design of the lateral housing covers (oil collecting pockets and return ducts) allows excess *oil* to return to the sump. A grease chamber is provided as an additional *sealing* between cover and labyrinth ring; the chamber is replenished with *grease* at regular intervals.

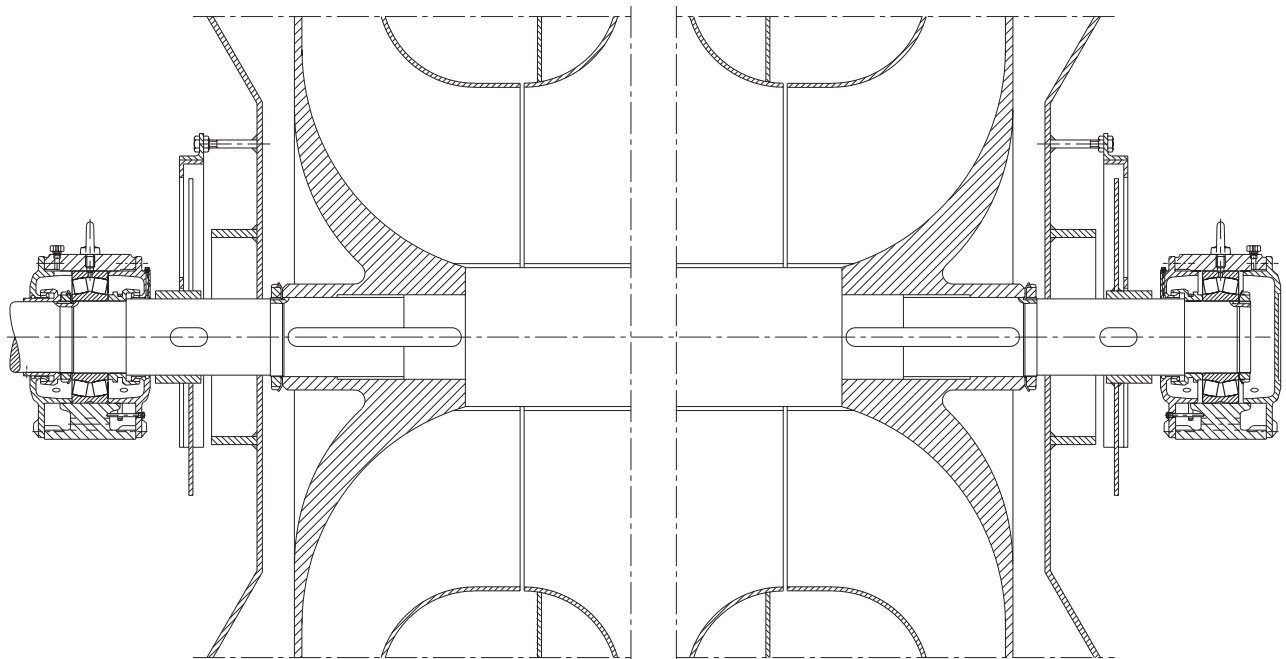

118: Rotor mounting of an exhauster

# 119 Hot gas fan

Gas temperature 150 °C; thrust 3 kN; operating speed 3,000 min<sup>-1</sup>.

## Bearing selection

The impeller of small and medium-sized fans is generally overhung. A particularly simple and economical arrangement is achieved by providing a one-piece housing incorporating two bearing mountings. The overhung impeller arrangement produces, however, a tilting moment from the impeller weight and unbalanced forces acting at the impeller. The radial loads resulting from this moment can be minimized by providing a large distance between the bearing locations in relation to the distance between the impeller and the first bearing location. This requirement is satisfied by plummer block housings of series FAG VR(E) (*grease lubrication*) or FAG VOS (*oil lubrication*) which were especially developed for fan applications. Since the operating speed is relatively high, bearings with a high *speed suitability* are used, e.g. cylindrical roller bearings for accommodating the radial loads and angular contact ball bearings for combined (i.e. radial and thrust) loads. The shaft diameter, dictated by strength considerations, is 85 mm.

The mounting consists of a plummer block housing (series VOS) for *oil lubrication* FAG VOB317. At the impeller end a cylindrical roller bearing FAG NU317E.M1.C3 acts as the *floating bearing*, at the drive end two *universal* angular contact ball bearings FAG 7317B.MP.UA are mounted in *O arrangement*. Suffix UA identifies bearings which can be universally mounted in *tandem*, *O* or *X arrangement*; the *X* and *O* arrangements feature a small *axial clearance*. The *axial clearance* combined with *oil lubrication* prevents overheating of the bearings and thus preloading.

## Machining tolerances

Cylindrical roller bearing: Shaft to m5; housing to K6.  
Angular contact ball bearings: Shaft to k6; housing to J6.

## Lubrication, sealing

*Oil lubrication.* The oil sump in the housing contains approximately 4 l of *oil*. Flinger rings feed the *oil* to the bearings. The sleeves mounted on the shaft feature flinger grooves. *Oil* collecting grooves and replenishable grease chambers are provided in the housing covers.

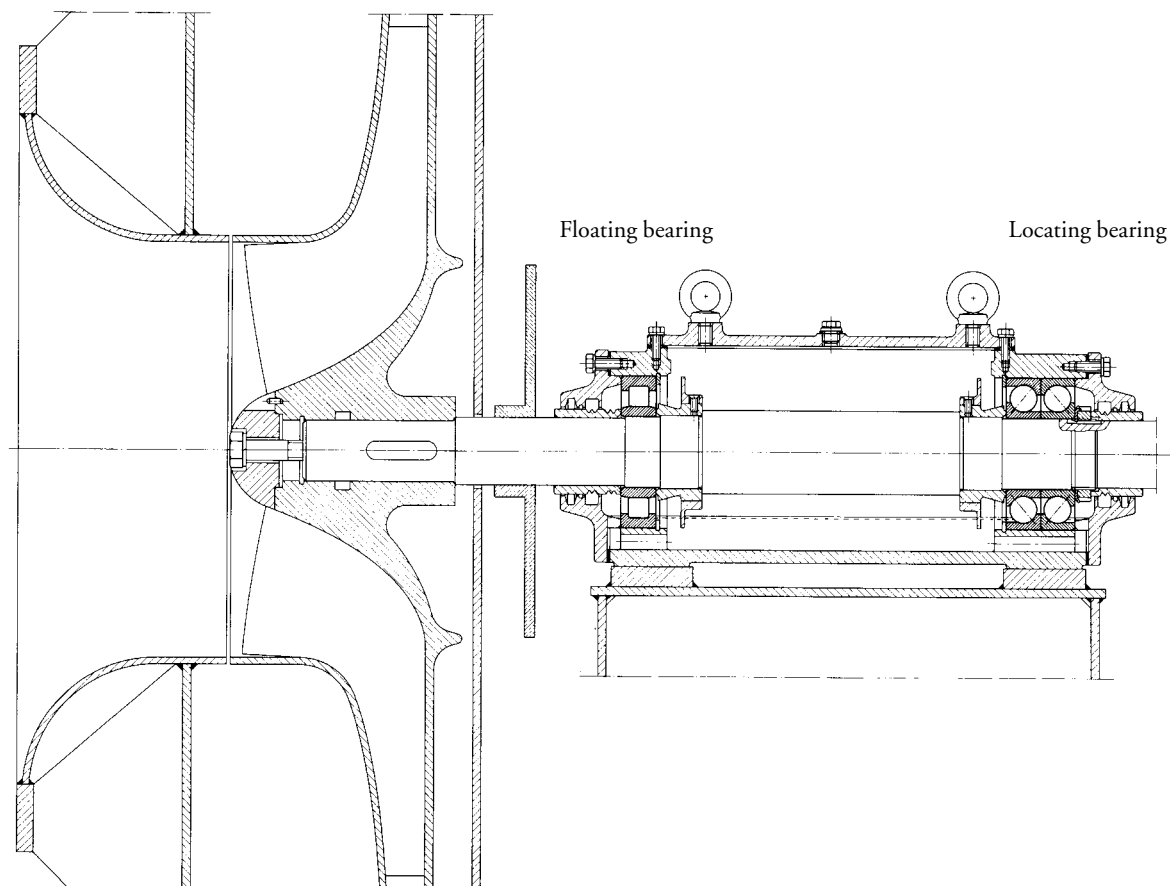

119: Rotor bearings of a hot gas ventilator

# 120 Fresh air blower

Weight of impeller 0.5 kN, weight of shaft 0.2 kN, thrust 0.3 kN; speed  $3,000 \text{ min}^{-1}$ .

## Bearing selection

Since a simple and economical mounting is required, a plummer block FAG SNV120.G944AA with a self-aligning ball bearing FAG 2311K.TV.C3 is arranged at either side of the impeller. *Self-aligning bearings* are necessary because of the difficulty in aligning two separately mounted housings so accurately that the bores are exactly aligned.

The housing is suitable for *grease* replenishment (suffix G944AA). A grease nipple is provided at the housing cap and a grease escape bore at the opposite side of the housing base.

As long as the impeller is satisfactorily balanced the inner rings of the bearings are *circumferentially loaded*.

They are mounted on the shaft with adapter sleeves FAG H2311. However, when the imbalance forces exceed the weight of impeller and shaft the *circumferential load* is transmitted to the outer ring.

Calculation of the *rating fatigue life* shows that the bearings are more than adequately dimensioned.

The SNV housings are made of grey-cast iron. The housing bodies are split to simplify mounting.

## Machining tolerances

Shaft to h9, cylindricity tolerance IT6/2 (DIN ISO 1101); housing to H7.

## Lubrication, sealing

The bearings are lubricated with FAG rolling bearing *grease Arcanol L71V*. The housing is sealed on each side by an FSV felt *seal*.

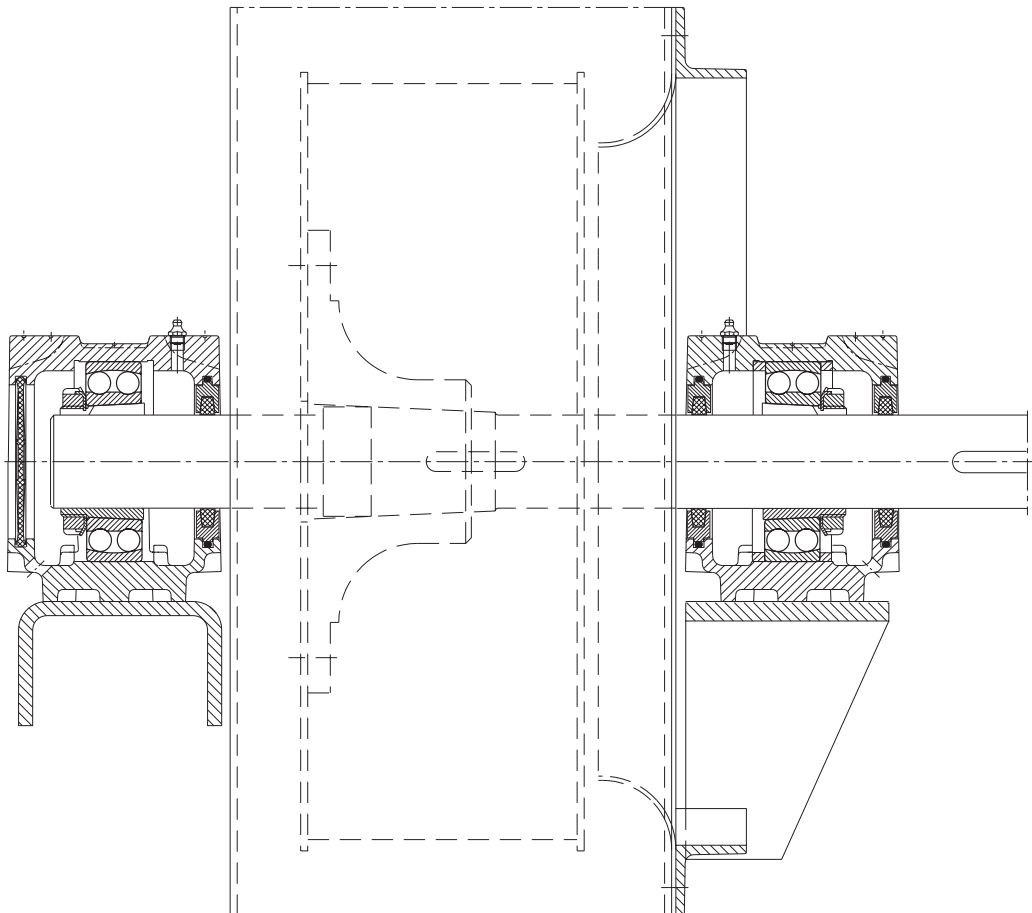

120: Rotor mounting of a fresh air blower

# 121 Optical telescope

## Operating data

The telescope is approximately 7 m high, 8 m long and weighs about 10 t, corresponding to 100 kN. The mirror diameter is 1 m. Due to the extremely low speed of rotation of the yoke axle (1 revolution in 24 hours), a very low and uniform bearing friction is required. Moreover, the yoke must be guided rigidly and with absolute zero clearance. Deflection of the yoke axle under the effect of the overhanging load must also be taken into account.

## Bearing selection

The *locating bearing* at the upper end of the yoke support is a high-precision double-row angular contact ball bearing with split outer ring. Its dimensions are 600 x 730 x 98 mm. The gap width between the two outer rings is such that, when *adjusting* the bearing axially, a preload of 35 kN is obtained. The lower end of the yoke axle is supported by a cylindrical roller bearing FAG NU1044K.M1.P51 acting as the *floating bearing*.

## Bearing assembly

Despite the large diameter of the yoke axle, the deflection still existing would result in increased friction in the preloaded angular contact ball bearing unless suitable countermeasures were taken. The problem was solved by mounting the cylindrical roller bearing in two outer shroud rings whose inside diameters are eccentric to the outside diameter. These shroud rings are rotated in opposite directions during mounting (D) until the shaft deflection at the angular contact ball bearing location is equalized. The crowned inner ring raceway of the cylindrical roller bearing allows for slight misalignments and shaft deflections.

## Lubrication, sealing

*Grease lubrication* (FAG rolling bearing grease *Arcanol* L186V). The cylindrical roller bearing is fitted with a gap-type *seal* with *grease* grooves, the angular contact ball bearing is sealed by a labyrinth.

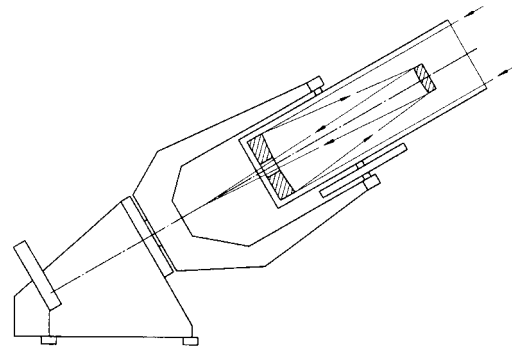
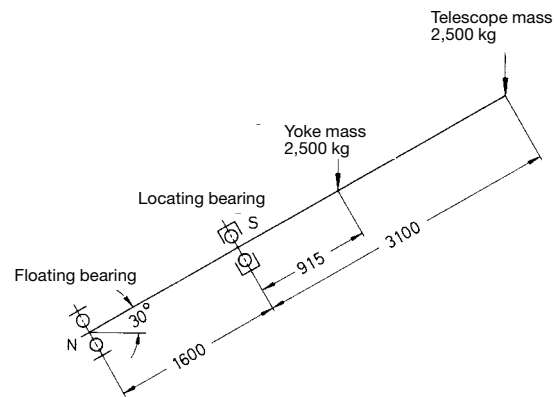

## Machining tolerances

Bearing	Seat	Diameter tolerance	Form tolerance (DIN ISO 1101)	Axial run-out tolerance of abutment shoulder
Angular contact ball bearing	Shaft Housing	j5 J6	IT2/2 IT3/2	IT2 IT2
Cylindrical roller bearing	Shaft, tapered Housing	taper 1 : 12 K6	IT2/2 IT3/2	IT2 IT2

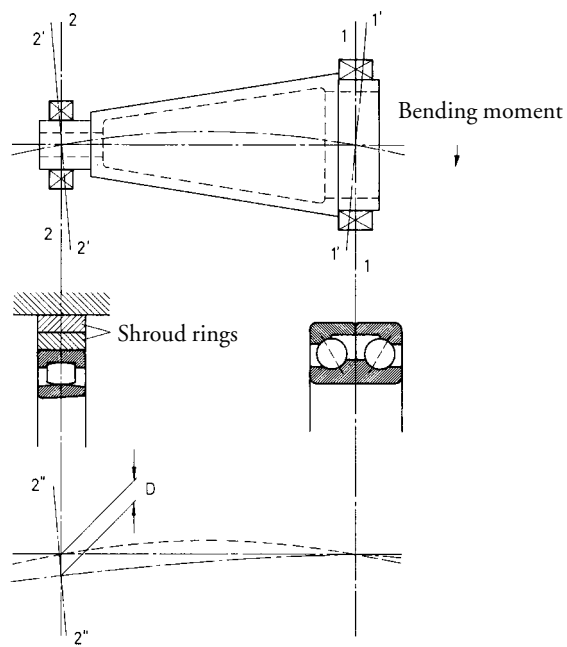
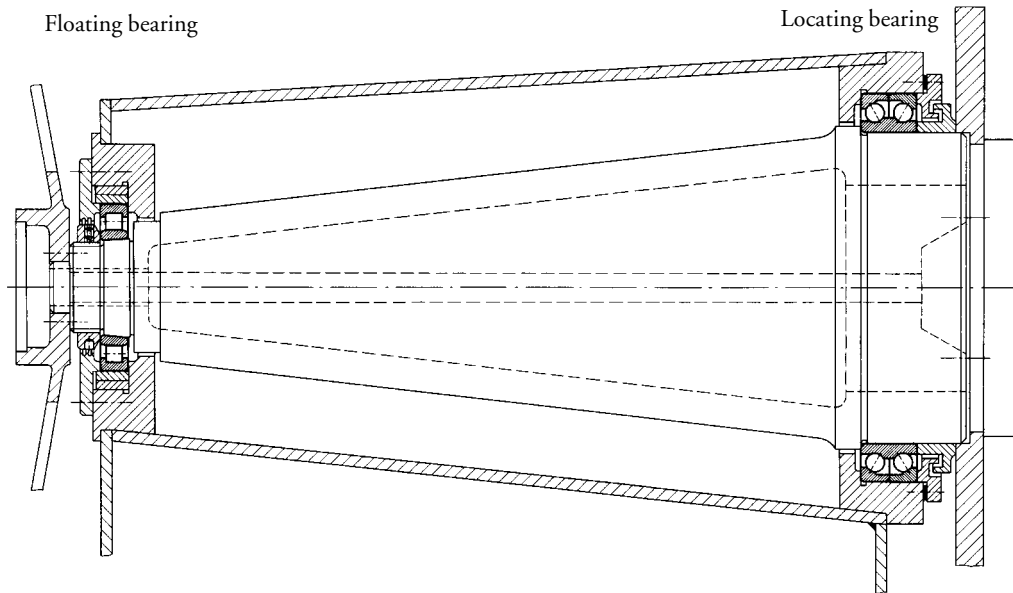

# 122–124 Radiotelescope

For radioastronomy highly sensitive radiotelescopes are used for picking up radio waves from the universe. The radiotelescope antenna is a huge reflector in the form of a paraboloid. The reflector is slewable about an axis parallel to the earth surface, the elevation axis. The whole telescope slews about the vertical axis, the azimuth axis.

## Operating data

Total mass of the radiotelescope 3,000 tons (load approximately 30,000 kN); reflector diameter 100 m, reflector mass 1,600 tons (load approximately 16,000 kN); speed of track rollers  $n_{\max} = 8 \text{ min}^{-1}$ ,  $n_{\min} = 0.01 \text{ min}^{-1}$ ; track diameter 64 m.

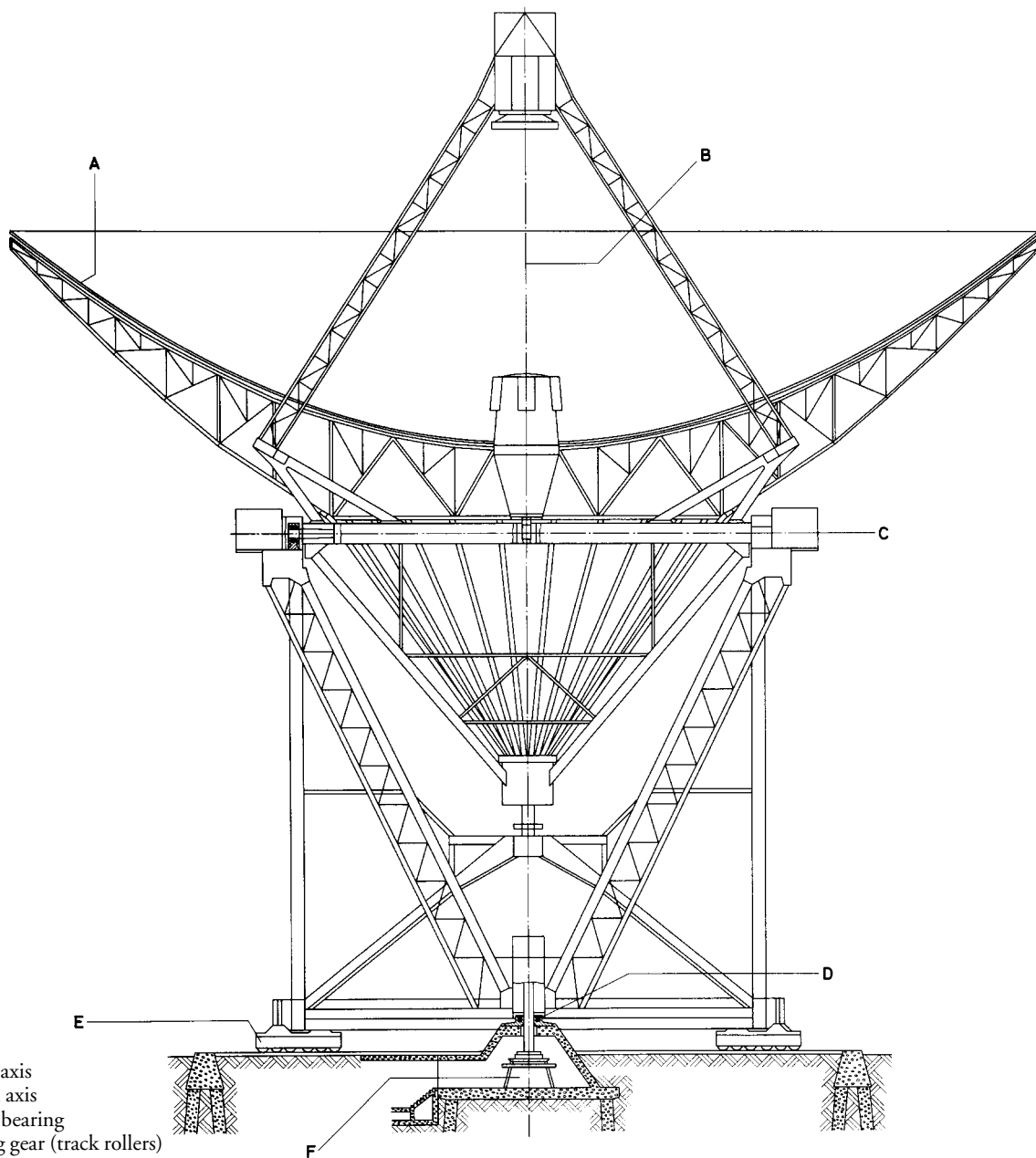

- A Reflector
- B Azimuth axis
- C Elevation axis
- D King pin bearing
- E Travelling gear (track rollers)
- F Data wheel

# 122 Elevation axis

The reflector is supported on two spherical roller bearings FAG 241/850BK30.P62 (*static load rating*  $C_0 = 49,000$  kN). Each of the two bearings has to accommodate a radial load of 8,000 kN. Added to this are the loads resulting from the effects of wind and snow on the reflector. Maximum loads in the horizontal direction may be 5,500 kN, in the vertical direction 3,000 kN. Bearing centre distance is 50 m. The bearings feature *tolerance class* P6 and *radial clearance* C2 (smaller than normal clearance CN). The bearings are mounted onto the journals with tapered sleeves by means of the hydraulic method. During mounting the *radial clearance* is eliminated by driving in the sleeves.

## Machining tolerances

Journal to h7 / housing to H6

## Lubrication, sealing

The spherical roller bearings are lubricated with FAG rolling bearing *grease Arcanol* L135V.

The bearings are sealed by a rubbing *seal*.

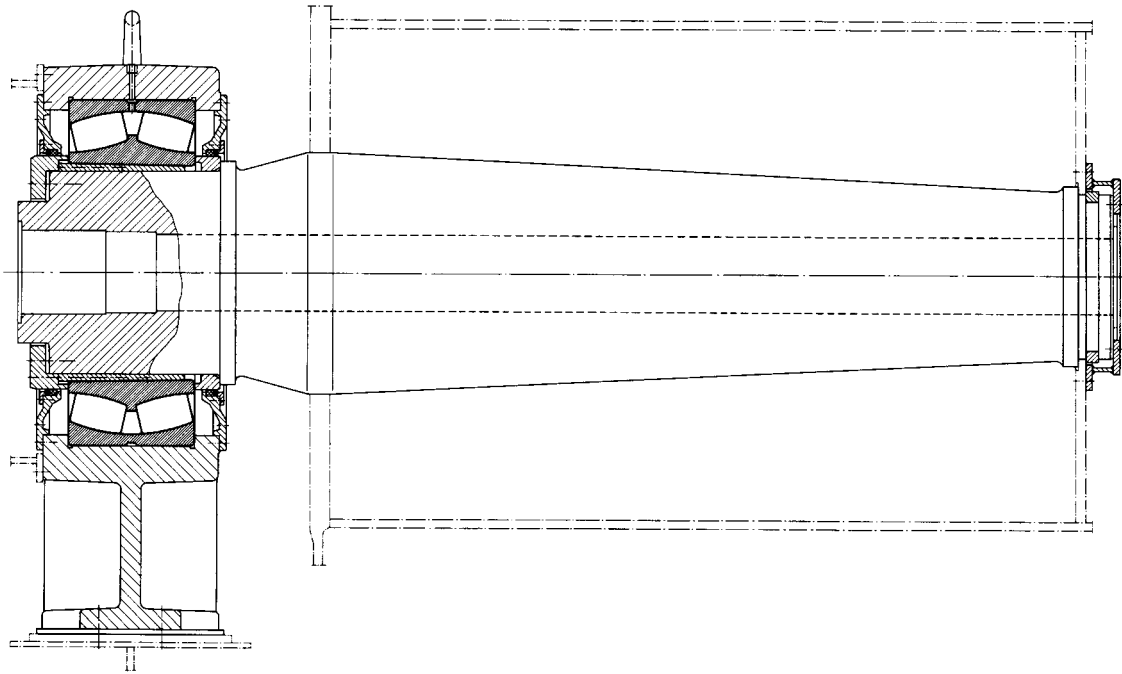

# 123 Azimuth axis (track roller and king pin bearings)

The radiotelescope with its complete superstructure is supported on a circular track of 64 m diameter. The roller track assembly, comprising four groups of eight rollers each, transmits the weight of approximately 30,000 kN.

Every second roller of a roller group is driven. Each roller is supported on two spherical roller bearings FAG 23060K.MB.C2. The bearings are mounted on the journal with withdrawal sleeves FAG AH3060H. In the most adverse case one bearing has to accommodate approximately 800 kN. With the *static load rating*  $C_0 = 3,550$  kN the bearings are safely dimensioned. The outer rings of the bearings are mounted into the housings with *axial clearance* so that a *floating bearing arrangement* is obtained. Since low friction is required the rollers to not incorporate wheel flanges. Thus it is necessary to radially guide the superstructure on a king pin bearing. The FAG cylindrical roller bearing provided for this purpose has the dimensions 1,580 x

2,000 x 250 mm. The cylindrical roller outside diameters are slightly crowned in order to avoid edge stressing. By mounting the bearing with a tapered sleeve the *radial clearance* can be eliminated, thus providing accurate radial guidance.

## Machining tolerances

Track rollers: Housing to H7

King pin: Journal to h7/ housing to M7

## Lubrication, sealing

The spherical roller bearings in the track rollers are lubricated with FAG rolling bearing *grease Arcanol L135V*. The cylindrical roller bearing for the king pin features circulating *oil* lubrication. *Sealing* by multiple labyrinths.

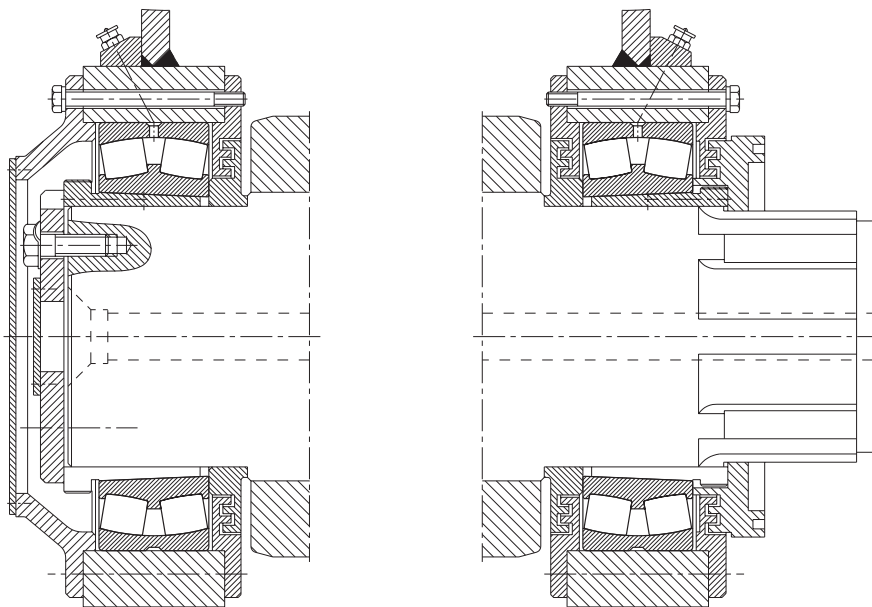

123a: Roller track assembly

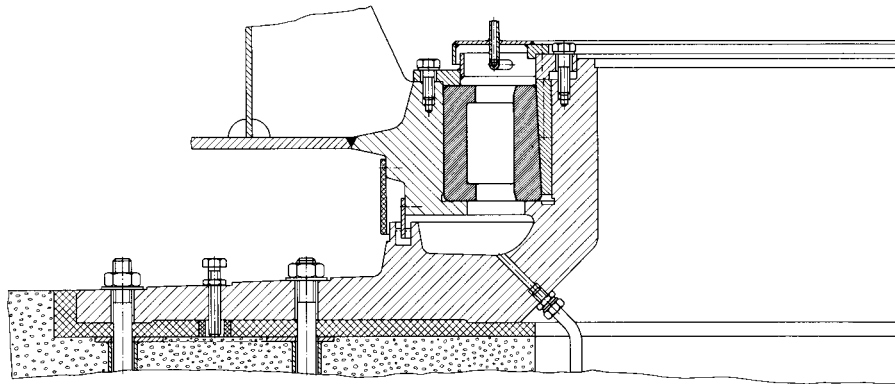

123b: King pin bearing

# 124 Data wheel

The data wheel is supported on a clearance-free FAG four-point bearing with the dimensions 1,300 x 1,500 x 80 mm.

Radial runout < 10 µm,  
Axial runout < 25 µm.

## Machining tolerances

The four-point bearing is fitted according to the actual bearing dimensions.

## Lubrication, sealing

The four-point bearing is fully immersed in *oil*.

*Sealing* by a multiple labyrinth.

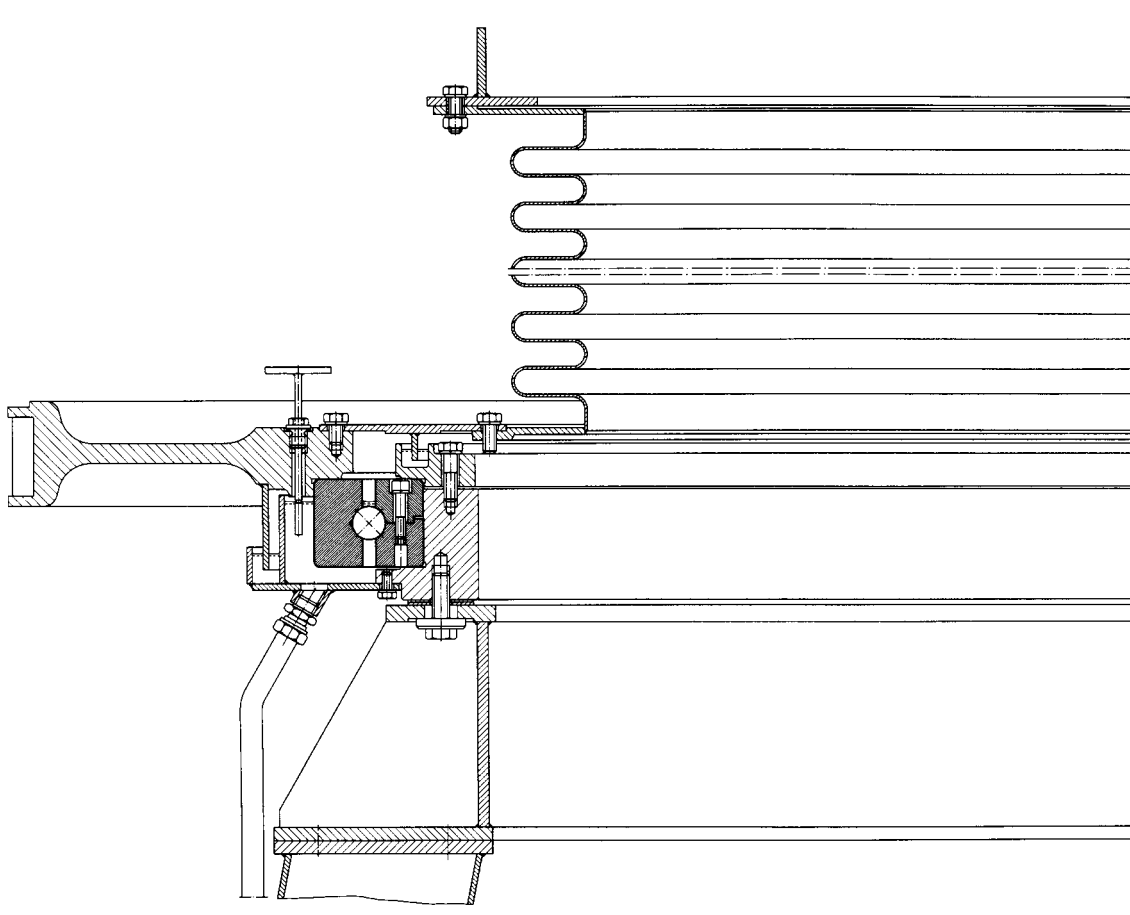

# Glossary

## Additives

Additives are oil-soluble substances added to *mineral oils* or mineral oil products. By chemical or physical action, they change or improve lubricant properties (oxidation stability, EP properties, foaming, *viscosity-temperature behaviour*, setting point, flow properties, etc.). Additives are also an important factor in calculating the *attainable life* (cp. also *Factor K*).

## Adjusted bearing arrangement/ Adjustment

An adjusted bearing arrangement consists of two symmetrically arranged *angular contact bearings* or *thrust bearings*. During mounting, one bearing ring (for an *O arrangement*, the inner ring; for an *X arrangement*, the outer ring) is displaced on its seat until the bearing arrangement has the appropriate *axial clearance* or the required preload. This means that the adjusted bearing arrangement is particularly suitable for those cases where a close axial guidance is required, for example, for pinion bearing arrangements with spiral toothed bevel gears.

Adjusted bearing arrangement (O arrangement)

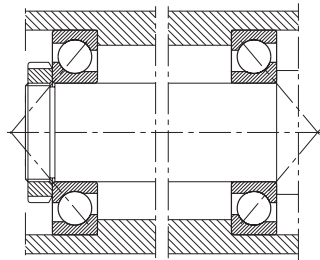

Adjusted bearing arrangement (X arrangement)

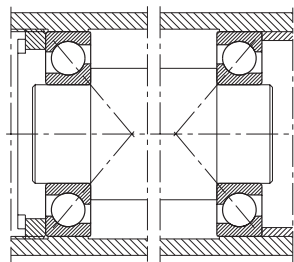

## Adjusted rating life calculation

The *nominal life*  $L$  or  $L_h$  deviates more or less from the really *attainable life* of rolling bearings. Therefore, the adjusted rating life calculation takes into account, in addition to the load, the failure probability (*factor*  $a_1$ ) and other significant operating conditions (*factor*  $a_{23}$  in the FAG procedure for calculating the *attainable life*).  
Cp. also *Modified life* in accordance with DIN ISO 281.

## Alignment

Self-aligning bearings are used to compensate for misalignment and tilting.

## Angular contact bearings

The term "angular contact bearing" is collectively used for single-row bearings whose *contact lines* are inclined to the radial plane. So, angular contact bearings are angular contact ball bearings, tapered roller bearings and spherical roller thrust bearings. Axially loaded deep groove ball bearings also act in the same way as angular contact bearings.

## Arcanol (FAG rolling bearing greases)

FAG rolling bearing greases Arcanol are field-proven *lubricating greases*. Their scopes of application were determined by FAG by means of the latest test methods under a large variety of operating conditions and with rolling bearings of all types. The eight Arcanol greases listed in the table on page 179 cover almost all demands on the lubrication of rolling bearings.

## Attainable life $L_{na}$ , $L_{hna}$

The FAG calculation method for determining the attainable life ( $L_{na}$ ,  $L_{hna}$ ) is based on DIN ISO 281 (cp. *Modified life*). It takes into account the influences of the operating conditions on the rolling *bearing life* and indicates the preconditions for reaching *endurance strength*.

$$L_{na} = a_1 \cdot a_{23} \cdot L \quad [10^6 \text{ revolutions}]$$

and

$$L_{hna} = a_1 \cdot a_{23} \cdot L_h \quad [\text{h}]$$

$a_1$  *factor*  $a_1$  for failure probability (DIN ISO 281);

for a normal (10%) failure probability  $a_1 = 1$ .

$a_{23}$  *factor*  $a_{23}$  (*life adjustment factor*)

$L$  *nominal rating life* [ $10^6$  revolutions]

$L_h$  *nominal rating life* [h]

If the quantities influencing the *bearing life* (e. g. load, speed, temperature, cleanliness, type and condition of lubricant) are variable, the attainable life ( $L_{hna1}$ ,  $L_{hna2}$ , ...) under constant conditions has to be determined for every operating time  $q$  [%]. The attainable life is calculated for the total operating time using the formula

$$L_{hna} = \frac{100}{\frac{q_1}{L_{hna1}} + \frac{q_2}{L_{hna2}} + \frac{q_3}{L_{hna3}}}$$

# Glossary

## Arcanol rolling bearing greases · Chemo-physical data · Directions for use

Arcanol	Thickener Base oil	Base oil viscosity at 40°C  mm <sup>2</sup> /s	Consistency NLGI- Class  DIN 51818	Temperature range  °C	Colour  RAL	Main characteristics Typical applications
L12V	Polyurea Mineral oil	ISO VG 100	2	-30...+160	2002 vermillion	Special grease for high temperatures  Couplings, electric machines (motors, generators)
L71V	Lithium soap Mineral oil	ISO VG 100	3	-30...+140	4008 signal violet	Standard grease for bearings with O.D.s > 62 mm  Large electric motors, wheel bearings for motor vehicles, ventilators
L74V	Special soap Synthetic oil	ISO VG 22	2	-40...+120	6018 yellow-green	Special grease for high speeds and low temperatures  Machine tools, spindle bearings, instruments
L78V	Lithium soap Mineral oil	ISO VG 100	2	-30...+130	1018 zinc yellow	Standard grease for bearings with O.D.s ≤ 62 mm  Small electric motors, agricultural and construction machinery, household appliances
L79V	Synthetic Synthetic oil	390	2	-30...+270	1024 yellow ochre	Special grease for extremely high temperatures and chemically aggressive environments  Track rollers in bakery machines, piston pins in compressors, kiln trucks, chemical plants (please observe safety data sheet)
L135V	Lithium soap with EP additives Mineral oil	85	2	-40...+150	2000 yellow orange	Special grease for high loads, high speeds, high temperatures  Rolling mills, construction machinery, motor vehicles, rail vehicles, spinning and grinding spindles
L186V	Lithium soap with EP additives Mineral oil	ISO VG 460	2	-20...+140	7005 mouse-grey	Special grease for extremely high loads, medium speeds, medium temperatures  Heavily stressed mining machinery, construction machinery, machines with oscillating movements
L223V	Lithium soap with EP additives Mineral oil	ISO VG 1000	2	-10...+140	5005 signal blue	Special grease for extremely high loads, low speeds  Heavily stressed mining machinery, construction machinery, particularly for impact loads and large bearings

# Glossary

## Axial clearance

The axial clearance of a bearing is the total possible axial displacement of one bearing ring measured without load. There is a difference between the axial clearance of the unmounted bearing and the axial *operating clearance* existing when the bearing is mounted and running at operating temperature.

## Base oil

is the oil contained in a *lubricating grease*. The amount of oil varies with the type of *thickener* and the grease application. The *penetration* number and the frictional behaviour of the grease vary with the amount of base oil and its *viscosity*.

## Basic $a_{23II}$ value

The basic  $a_{23II}$  value is the basis for determining *factor  $a_{23}$* , used in *attainable life* calculation.

## Bearing life

The life of *dynamically stressed* rolling bearings, as defined by DIN ISO 281, is the operating time until failure due to material fatigue (*fatigue life*).

By means of the classical calculation method, a comparison calculation, the *nominal rating life*  $L$  or  $L_h$ , is determined; by means of the refined FAG calculation process, the *attainable life*  $L_{na}$  or  $L_{hna}$  is determined (see also *factor  $a_{23}$* ).

## Cage

The cage of a rolling bearing prevents the *rolling elements* from rubbing against each other. It keeps them evenly spaced and guides them through unloaded sections of the bearing circumference.

The cage of a needle roller bearing also has to guide the needle rollers parallel to the axis. In the case of *separable bearings* the cage retains the *rolling element set*, thus facilitating bearing mounting. Rolling bearing cages are classified into the categories *pressed cages* and *machined/moulded cages*.

## Circumferential load

If the ring under consideration rotates in relation to the radial load, the entire circumference of the ring is, during each revolution, subjected to the maximum

load. This ring is circumferentially loaded. Bearings with circumferential load must be mounted with a tight *fit* to avoid sliding (cp. *Point load*, *Oscillating load*).

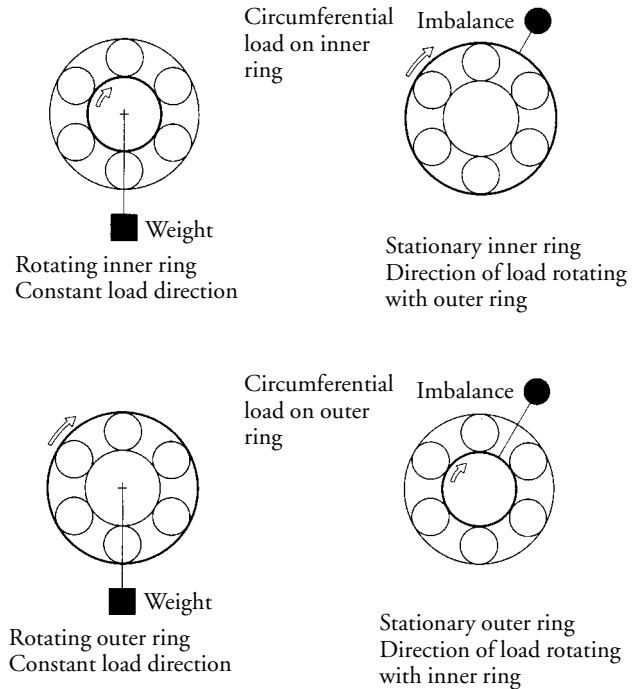

## Cleanliness factor $s$

The cleanliness factor  $s$  quantifies the effect of contamination on the *attainable life*. The product of  $s$  and the *basic  $a_{23II}$  factor* is the *factor  $a_{23}$* .

*Contamination factor  $V$*  is required to determine  $s$ .

$s = 1$  always applies to normal cleanliness ( $V = 1$ ). With improved cleanliness ( $V = 0.5$ ) and utmost cleanliness ( $V = 0.3$ ) a cleanliness factor  $s > 1$  is obtained from the right diagram (a) on page 181, based on the *stress index  $f_{s*}$*  and depending on the *viscosity ratio  $\kappa$* .

$s = 1$  applies to  $\kappa < 0.4$ .

With  $V = 2$  (moderately contaminated lubricant) to  $V = 3$  (heavily contaminated lubricant),  $s < 1$  is obtained from diagram (b).

## Combined load

This applies when a bearing is loaded both radially and axially, and the resulting load acts, therefore, at the *load angle  $\beta$* .

Depending on the type of load, the *equivalent dynamic load  $P$*  or the *equivalent static load  $P_0$*  is determined with the radial component  $F_r$  and the thrust component  $F_a$  of the combined load.

# Glossary

Diagram for determining the cleanliness factor  $s$

- a Diagram for improved to utmost cleanliness
- b Diagram for moderately contaminated lubricant and heavily contaminated lubricant

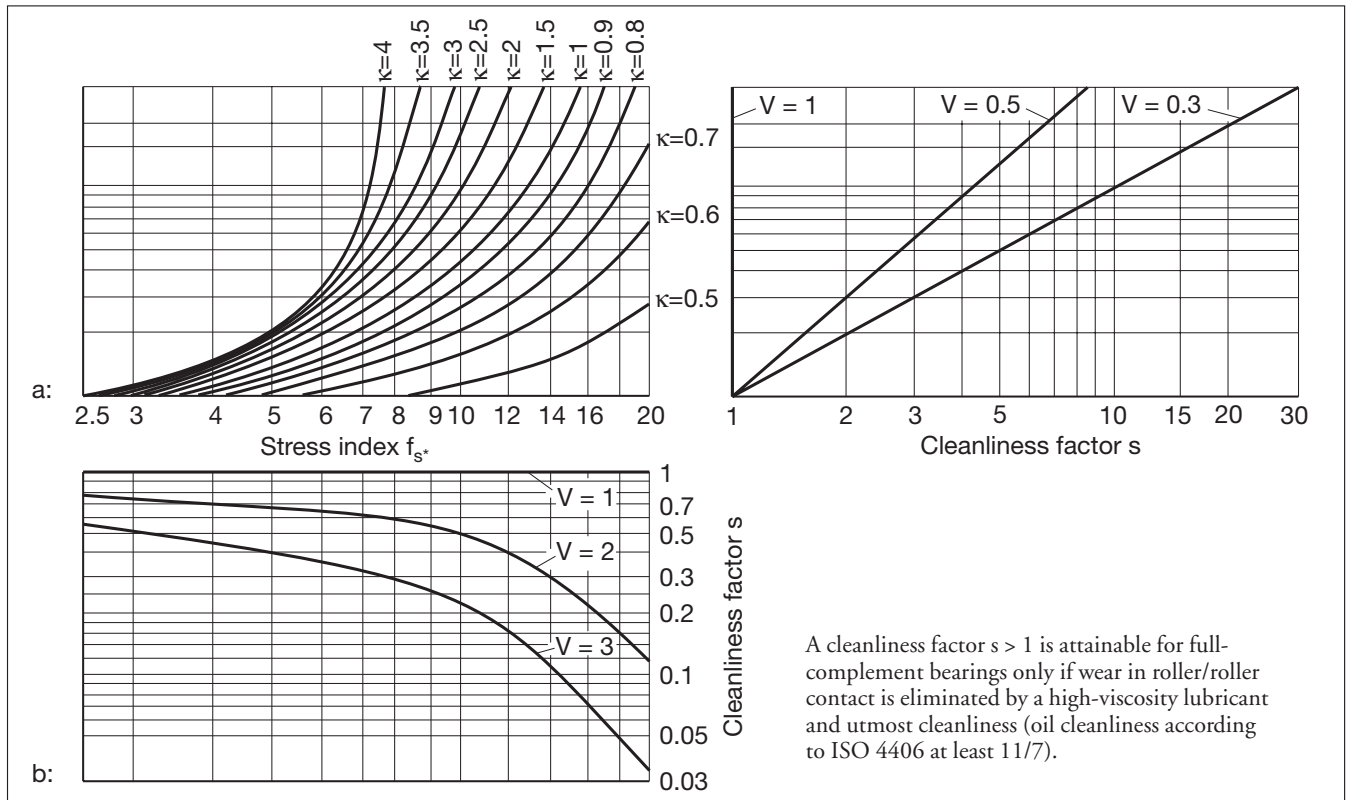

## Consistency

Measure of the resistance of a *lubricating grease* to being deformed.  
Consistency classification to NLGI, cp. *Penetration*.

## Contact angle $\alpha$

The contact angle  $\alpha$  is the angle formed by the *contact lines* of the *rolling elements* and the radial plane of the bearing.  $\alpha_0$  refers to the nominal contact angle, i.e. the contact angle of the load-free bearing. Under axial loads the contact angle of deep groove ball bearings, angular contact ball bearings etc. increases. Under a *combined load* it changes from one *rolling element* to the next. These changing contact angles are taken into account when calculating the pressure distribution within the bearing. Ball bearings and roller bearings with symmetrical *rolling elements* have identical contact angles at their inner rings and outer rings. In roller bearings with asymmetrical rollers the contact angles at inner ring and outer ring are not identical. The equilibrium of forces in these bearings is maintained by a force component which is directed towards the lip.

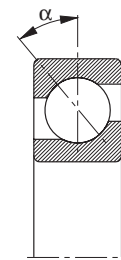

## Contact line

The *rolling elements* transmit loads from one bearing ring to the other in the direction of the contact lines.

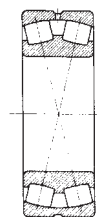

# Glossary

## Contamination factor V

The contamination factor V indicates the degree of cleanliness in the lubricating gap of rolling bearings based on the oil cleanliness classes defined in ISO 4406.

When determining the *factor*  $a_{23}$  and the *attainable life*, V is used, together with the *stress index*  $f_s$  and the *viscosity ratio*  $\kappa$ , to determine the *cleanliness factor* s. V depends on the bearing cross section  $(D - d)/2$ , the type of contact between the mating surfaces and especially the cleanliness level of the oil.

If hard particles from a defined size on are cycled in the most heavily stressed contact area of a rolling bearing, the resulting indentations in the contact surfaces lead to premature material fatigue. The smaller the contact area, the more damaging the effect of a particle above a certain size when being cycled. Small bearings with point contact are especially vulnerable.

According to today's knowledge the following cleanliness scale is useful (the most important values are in boldface):

V = 0.3 **utmost cleanliness**

V = 0.5 improved cleanliness

V = 1 **normal cleanliness**

V = 2 moderately contaminated lubricant

V = 3 **heavily contaminated lubricant**

Preconditions for utmost cleanliness (V = 0.3):

- bearings are greased and protected by seals or shields against dust by the manufacturer
- grease lubrication by the user who fits the bearings into clean housings under top cleanliness conditions, lubricates them with clean grease and takes care that dirt cannot enter the bearing during operation
- flushing the oil circulation system prior to the first operation of the cleanly fitted bearings and taking care that the oil cleanliness class is ensured during the entire operating time

## Guide values for V

(D-d)/2 mm	V	Point contact required oil cleanliness class according to ISO 4406	guide values for filtration ratio according to ISO 4572	Line contact required oil cleanliness class according to ISO 4406	guide values for filtration ratio according to ISO 4572
≤ 12.5	0.3	11/8	$\beta_3 \geq 200$	12/9	$\beta_3 \geq 200$
	0.5	12/9	$\beta_3 \geq 200$	13/10	$\beta_3 \geq 75$
	1	14/11	$\beta_6 \geq 75$	15/12	$\beta_6 \geq 75$
	2	15/12	$\beta_6 \geq 75$	16/13	$\beta_{12} \geq 75$
	3	16/13	$\beta_{12} \geq 75$	17/14	$\beta_{25} \geq 75$
> 12.5...20	0.3	12/9	$\beta_3 \geq 200$	13/10	$\beta_3 \geq 75$
	0.5	13/10	$\beta_3 \geq 75$	14/11	$\beta_6 \geq 75$
	1	15/12	$\beta_6 \geq 75$	16/13	$\beta_{12} \geq 75$
	2	16/13	$\beta_{12} \geq 75$	17/14	$\beta_{25} \geq 75$
	3	18/14	$\beta_{25} \geq 75$	19/15	$\beta_{25} \geq 75$
> 20...35	0.3	13/10	$\beta_3 \geq 75$	14/11	$\beta_6 \geq 75$
	0.5	14/11	$\beta_6 \geq 75$	15/12	$\beta_6 \geq 75$
	1	16/13	$\beta_{12} \geq 75$	17/14	$\beta_{12} \geq 75$
	2	17/14	$\beta_{25} \geq 75$	18/15	$\beta_{25} \geq 75$
	3	19/15	$\beta_{25} \geq 75$	20/16	$\beta_{25} \geq 75$
> 35	0.3	14/11	$\beta_6 \geq 75$	14/11	$\beta_6 \geq 75$
	0.5	15/12	$\beta_6 \geq 75$	15/12	$\beta_{12} \geq 75$
	1	17/14	$\beta_{12} \geq 75$	18/14	$\beta_{25} \geq 75$
	2	18/15	$\beta_{25} \geq 75$	19/16	$\beta_{25} \geq 75$
	3	20/16	$\beta_{25} \geq 75$	21/17	$\beta_{25} \geq 75$

The oil cleanliness class can be determined by means of oil samples by filter manufacturers and institutes. It is a measure of the probability of life-reducing particles being cycled in a bearing. Suitable sampling should be observed (see e. g. DIN 51570). Today, online measuring instruments are available. The cleanliness classes are reached if the entire oil volume flows through the filter within a few minutes.

To ensure a high degree of cleanliness flushing is required **prior** to bearing operation.

For example, a filtration ratio  $\beta_3 \geq 200$  (ISO 4572) means that in the so-called multi-pass test only one of 200 particles  $\geq 3 \mu\text{m}$  passes the filter. Filters with coarser filtration ratios than  $\beta_{25} \geq 75$  should not be used due to the ill effect on the other components within the circulation system.

---

# Glossary

---

Preconditions for normal cleanliness ( $V = 1$ ):

- good *sealing* adapted to the environment
- cleanliness during mounting
- oil cleanliness according to  $V = 1$
- observing the recommended oil change intervals

Possible causes of heavy lubricant contamination ( $V = 3$ ):

- the cast housing was inadequately cleaned
- abraded particles from components which are subject to wear enter the circulating oil system of the machine
- foreign matter penetrates into the bearing due to unsatisfactory *sealing*
- water which entered the bearing, also condensation water, caused standstill corrosion or deterioration of the lubricant properties

The necessary oil cleanliness class according to ISO 4406 is an objectively measurable level of the contamination of a lubricant.

In accordance with the particle-counting method, the number of all particles  $> 5 \mu\text{m}$  and all particles  $> 15 \mu\text{m}$  are allocated to a certain ISO oil cleanliness class. For example, an oil cleanliness class 15/12 according to ISO 4406 means that between 16,000 and 32,000 particles  $> 5 \mu\text{m}$  and between 2,000 and 4,000 particles  $> 15 \mu\text{m}$  are present per 100 ml of a fluid.

A defined filtration ratio  $\beta_x$  should exist in order to reach the oil cleanliness required.

The filtration ratio is the ratio of all particles  $> x \mu\text{m}$  before passing the filter to the particles  $> x \mu\text{m}$  which have passed the filter. For example, a filtration ratio  $\beta_3 \geq 200$  means that in the so-called multi-pass test (ISO 4572) only one of 200 particles  $\geq 3 \mu\text{m}$  passes the filter.

## Counter guidance

*Angular contact bearings* and single-direction *thrust bearings* accommodate axial forces only in one direction. A second, symmetrically arranged bearing must be used for "counter guidance", i.e. to accommodate the axial forces in the other direction.

## Curvature ratio

In all bearing types with a curved raceway profile the radius of the raceway is slightly larger than that of the *rolling elements*. This curvature difference in the axial plane is defined by the curvature ratio  $\kappa$ . The curva-

ture ratio is the curvature difference between the rolling element radius and the slightly larger groove radius.

$$\text{curvature ratio } \kappa = \frac{\text{groove radius} - \text{rolling element radius}}{\text{rolling element radius}}$$

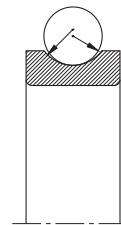

## Dynamic load rating C

The dynamic load rating C (see FAG catalogues) is a factor for the load carrying capacity of a rolling bearing under *dynamic load*. It is defined, in accordance with DIN ISO 281, as the load a rolling bearing can theoretically accommodate for a *nominal life* L of  $10^6$  revolutions (*fatigue life*).

## Dynamic stressing/dynamic load

Rolling bearings are dynamically stressed when one ring rotates relative to the other under load. The term "dynamic" does not refer, therefore, to the effect of the load but rather to the operating condition of the bearing. The magnitude and direction of the load can remain constant.

When calculating the bearings, a dynamic stress is assumed when the speed n amounts to at least  $10 \text{ min}^{-1}$  (see *Static stressing*).

## Endurance strength

Tests by FAG and field experience have proved that, under the following conditions, rolling bearings can be fail-safe:

- utmost cleanliness in the lubricating gap (*contamination factor*  $V = 0.3$ )
- complete separation of the components in rolling contact by the lubricating film (*viscosity ratio*  $\kappa \geq 4$ )
- load according to *stress index*  $f_{s*} \geq 8$

# Glossary

## EP additives

Wear-reducing *additives* in *lubricating greases* and *lubricating oils*, also referred to as extreme pressure lubricants.

## Equivalent dynamic load P

For *dynamically loaded* rolling bearings operating under a *combined load*, the calculation is based on the equivalent dynamic load. This is a radial load for radial bearings and an axial and central load for axial bearings, having the same effect on *fatigue* as the *combined load*. The equivalent dynamic load P is calculated by means of the following equation:

$$P = X \cdot F_r + Y \cdot F_a \quad [\text{kN}]$$

$F_r$  radial load [kN]

$F_a$  axial load [kN]

X radial factor (see FAG catalogues)

Y thrust factor (see FAG catalogues)

## Equivalent static load $P_0$

Statically stressed rolling bearings which operate under a *combined load* are calculated with the equivalent static load. It is a radial load for *radial bearings* and an axial and centric load for *thrust bearings*, having the same effect with regard to permanent deformation as the *combined load*.

The equivalent static load  $P_0$  is calculated with the formula:

$$P = X_0 \cdot F_r + Y_0 \cdot F_a \quad [\text{kN}]$$

$F_r$  radial load [kN]

$F_a$  axial load [kN]

$X_0$  radial factor (see FAG catalogues)

$Y_0$  thrust factor (see FAG catalogues)

## Factor $a_1$

Generally (nominal rating life  $L_{10}$ ), 10 % failure probability is taken. The factor  $a_1$  is also used for failure probabilities between 10 % and 1 % for the calculation of the *attainable life*, see following table.

Failure probability %	10	5	4	3	2	1
Fatigue life	$L_{10}$	$L_5$	$L_4$	$L_3$	$L_2$	$L_1$
Factor $a_1$	1	0.62	0.53	0.44	0.33	0.21

## Factor $a_{23}$ (life adjustment factor)

The  $a_{23}$  factor is used to calculate the *attainable life*. FAG use  $a_{23}$  instead of the mutually dependent adjustment factors for material ( $a_2$ ) and operating conditions ( $a_3$ ) indicated in DIN ISO 281.

$$a_{23} = a_2 \cdot a_3$$

The  $a_{23}$  factor takes into account effects of:

- amount of load (*stress index*  $f_s^*$ ),
- lubricating film thickness (*viscosity ratio*  $\kappa$ ),
- lubricant *additives* (value K),
- contaminants in the lubricating gap (*cleanliness factor* s),
- bearing type (value K).

The diagram on page 185 is the basis for the determination of the  $a_{23}$  factor using the *basic  $a_{23II}$  value*. The  $a_{23}$  factor is obtained from the equation  $a_{23II} \cdot s$  (s being the *cleanliness factor*).

The *viscosity ratio*  $\kappa = \nu/\nu_1$  and the *value K* are required for locating the *basic value*. The most important zone (II) in the diagram applies to normal cleanliness (s = 1).

The *viscosity ratio*  $\kappa$  is a measure of the lubricating film development in the bearing.

$\nu$  *operating viscosity* of the lubricant, depending on the nominal viscosity (at 40 °C) and the operating temperature t (fig. 1). In the case of *lubricating greases*,  $\nu$  is the operating viscosity of the *base oil*.

$\nu_1$  *rated viscosity*, depending on mean bearing diameter  $d_m$  and operating speed n (fig. 2).

The diagram (fig. 3) for determining the *basic  $a_{23II}$  factor* is subdivided into zones I, II and III.

Most applications in rolling bearing engineering are covered by zone II. It applies to normal cleanliness (*contamination factor*  $V = 1$ ). In zone II,  $a_{23}$  can be determined as a function of  $\kappa$  by means of *value K*.

With  $K = 0$  to 6,  $a_{23II}$  is found on one of the curves in zone II of the diagram.

With  $K > 6$ ,  $a_{23}$  must be expected to be in zone III. In such a case conditions should be improved so that zone II can be reached.

# Glossary

1: Average viscosity-temperature behaviour of mineral oils; diagram for determining the operating viscosity

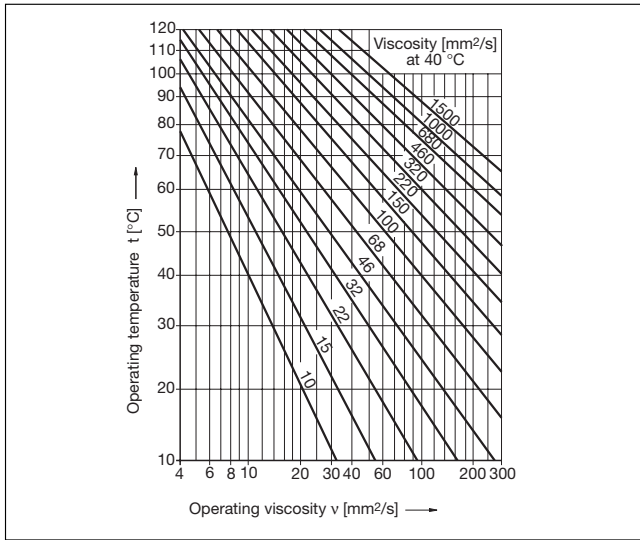

2: Rated viscosity  $v_1$

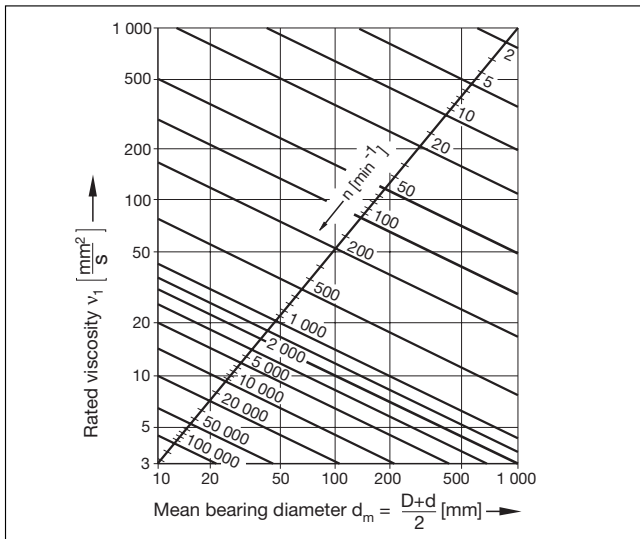

## Fatigue life

The fatigue life of a rolling bearing is the operating time from the beginning of its service until failure due to material fatigue. The fatigue life is the upper limit of *service life*.

The classical calculation method, a comparison calculation, is used to determine the *nominal life*  $L$  or  $L_h$ ; by means of the refined FAG calculation process the *attainable life*  $L_{na}$  or  $L_{hna}$  is determined (see also  $a_{23}$  factor).

3: Basic  $a_{23II}$  factor for determining the factor  $a_{23}$

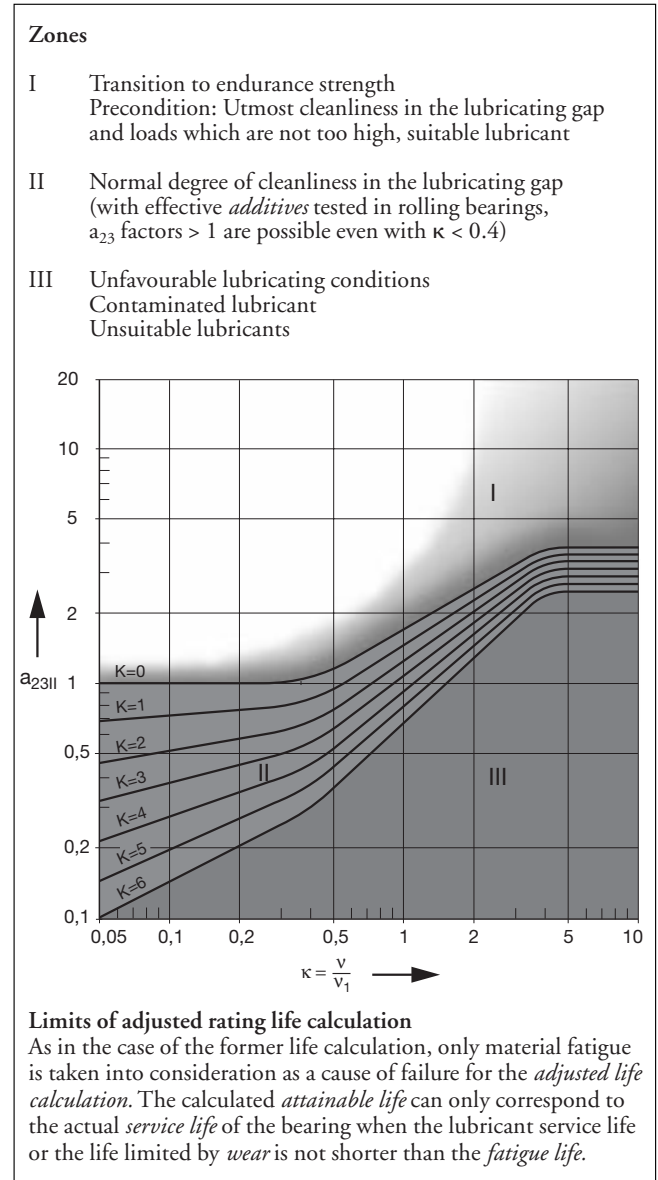

## Fits

The tolerances for the bore and for the outside diameter of rolling bearings are standardized in DIN 620 (cp. *Tolerance class*). The seating characteristics required for reliable bearing operation, which are dependent on the operating conditions of the application, are obtained by the correct selection of shaft and housing machining tolerances.

For this reason, the seating characteristics of the rings are indicated by the shaft and housing tolerance symbols.

Three factors should be borne in mind in the selection of fits:

# Glossary

1. Safe retention and uniform support of the bearing rings
2. Simplicity of mounting and dismounting
3. Axial freedom of the *floating bearing*

The simplest and safest means of ring retention in the circumferential direction is achieved by a tight fit. A tight fit will support the rings evenly, a factor which is indispensable for the full utilization of the load carrying capacity. Bearing rings accommodating a *circumferential load* or an *oscillating load* are always fitted tightly. Bearing rings accommodating a *point load* may be fitted loosely.

The higher the load the tighter should be the interference fit provided, particularly for shock loading. The temperature gradient between bearing ring and mating component should also be taken into account. Bearing type and size also play a role in the selection of the correct fit.

## Floating bearing

In a *locating/floating bearing arrangement* the floating bearing compensates for axial thermal expansion. Cylindrical roller bearings of NU and N designs, as well as needle roller bearings, are ideal floating bearings. Differences in length are compensated for in the floating bearing itself. The bearing rings can be given tight *fits*.

*Non-separable bearings*, such as deep groove ball bearings and spherical roller bearings, can also be used as floating bearings. In such a case one of the two bearing rings is given a loose *fit*, with no axial mating surface so that it can shift freely on its seat.

## Floating bearing arrangement

A floating bearing arrangement is an economical solution where no close axial shaft guidance is required. The design is similar to that of an *adjusted bearing arrangement*. In a floating bearing arrangement, however, the shaft can shift relative to the housing by the *axial clearance*  $s$ . The value  $s$  is determined depending on the required guiding accuracy in such a way that detrimental axial preloading of the bearings is prevented even under unfavourable thermal conditions.

In floating bearing arrangements with NJ cylindrical roller bearings, length variations are compensated for in the bearings. Inner and outer rings can be *fitted* tightly.

*Non-separable radial bearings* such as deep groove ball bearings, self-aligning ball bearings and spherical roller bearings can also be used. One ring of each bearing – generally the outer ring – is given a loose *fit*.

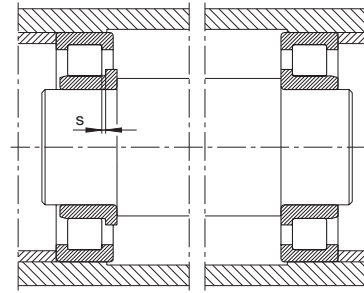

## Grease, grease lubrication

cp. Lubricating grease

## Grease service life

The grease service life is the period from start-up until the failure of a bearing as a result of lubrication breakdown.

The grease service life is determined by the

- amount of grease
- grease type (*thickener, base oil, additives*)
- bearing type and size
- type and amount of loading
- *speed index*
- bearing temperature

## Index of dynamic stressing $f_L$

The value recommended for dimensioning can be expressed, instead of in hours, as the index of dynamic stressing  $f_L$ . It is calculated from the *dynamic load rating*  $C$ , the *equivalent dynamic load*  $P$  and the *speed factor*  $f_n$ .

$$f_L = \frac{C}{P} \cdot f_n$$

The  $f_L$  value to be obtained for a correctly dimensioned bearing arrangement is an empirical value obtained from field-proven identical or similar bearing mountings.

The values indicated in various FAG publications take into account not only an adequate *fatigue life* but also other requirements such as low weight for light-weight constructions, adaptation to given mating parts, higher-than-usual peak loads, etc. The  $f_L$  values conform with the latest standards resulting from technical progress. For comparison with a field-proven bearing mounting the calculation of stressing must, of course, be based on the same former method.

Based on the calculated  $f_L$  value, the *nominal rating life*  $L_h$  in hours can be determined.

# Glossary

$$L_h = 500 \cdot f_L^p \quad [h]$$

$p = 3$  for ball bearings

$p = \frac{10}{3}$  for roller bearings and needle roller bearings

## Index of static stressing $f_s$

The index of static stressing  $f_s$  for *statically loaded bearings* is calculated to ensure that a bearing with an adequate load carrying capacity has been selected. It is calculated from the *static load rating*  $C_0$  and the *equivalent static load*  $P_0$ .

$$f_s = \frac{C_0}{P_0}$$

The index  $f_s$  is a safety factor against permanent deformations of the contact areas between raceway and the most heavily loaded *rolling element*. A high  $f_s$  value is required for bearings which must run smoothly and particularly quietly. Smaller values suffice where a moderate degree of running quietness is required. The following values are generally recommended:

$f_s = 1.5 \dots 2.5$  for a high degree  
 $f_s = 1 \dots 1.5$  for a normal degree  
 $f_s = 0.7 \dots 1$  for a moderate degree

## K value

The K value is an auxiliary quantity needed to determine the *basic  $a_{23II}$  factor* when calculating the *attainable life* of a bearing.

$$K = K_1 + K_2$$

$K_1$  depends on the bearing type and the *stress index*  $f_s$ , see diagram.

$K_2$  depends on the *stress index*  $f_s$  and the *viscosity ratio*  $\kappa$ . The values in the diagram (below) apply to lubricants without *additives* and lubricants with *additives* whose effects in rolling bearings was not tested.

With  $K = 0$  to 6, the *basic  $a_{23II}$  value* is found on one of the curves in zone II of diagram 3 on page 185 (cp. *factor  $a_{23}$* ).

## Value $K_1$

- a ball bearings
- b tapered roller bearings, cylindrical roller bearings
- c spherical roller bearings, spherical roller thrust bearings<sup>3)</sup>, cylindrical roller thrust bearings<sup>1), 3)</sup>
- d full complement cylindrical roller bearings<sup>1), 2)</sup>

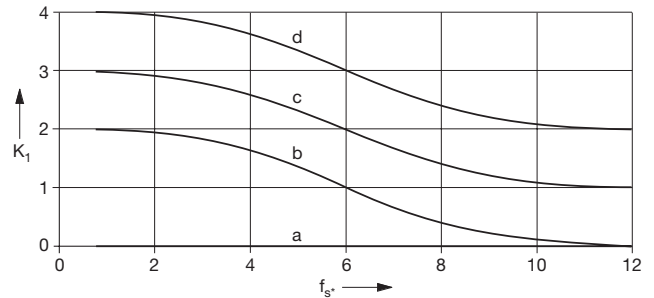

- <sup>1)</sup> Attainable only with lubricant filtering corresponding to  $V < 1$ , otherwise  $K_1 \geq 6$  must be assumed.
- <sup>2)</sup> To be observed for the determination of  $\nu$ : the friction is at least twice the value in caged bearings. This results in higher bearing temperature.
- <sup>3)</sup> Minimum load must be observed.

## Value $K_2$

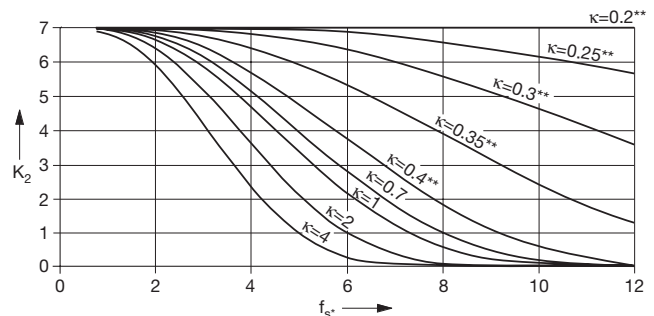

- $K_2$  equals for 0 for lubricants with additives with a corresponding suitability proof.
- \*\* With  $\kappa \leq 0.4$  wear dominates unless eliminated by suitable additives.

## Kinematically permissible speed

The kinematically permissible speed is indicated in the FAG catalogues also for bearings for which – according to DIN 732 – no *thermal reference speed* is defined. Decisive criteria for the kinematically permissible speed are e.g. the strength limit of the bearing components or the permissible sliding velocity of rubbing *seals*. The kinematically permissible speed can be reached, for example, with

- specially designed lubrication
- bearing clearance adapted to the operating conditions
- accurate machining of the bearing seats
- special regard to heat dissipation

## Life

Cp. also *Bearing life*.

# Glossary

## Load angle

The load angle  $\beta$  is the angle between the resultant applied load  $F$  and the radial plane of the bearing. It is the resultant of the radial component  $F_r$  and the axial component  $F_a$ :

$$\tan \beta = F_a/F_r$$

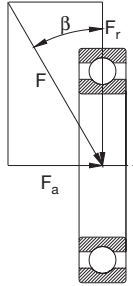

## Load rating

The load rating of a bearing reflects its load carrying capacity. Every rolling bearing has a *dynamic load rating* (DIN ISO 281) and a *static load rating* (DIN ISO 76). The values are indicated in the FAG rolling bearing catalogues.

## Locating bearing

In a *locating/floating bearing arrangement*, the bearing which guides the shaft axially in both directions is referred to as locating bearing. All bearing types which accommodate thrust in either direction in addition to radial loads are suitable. Angular contact ball bearing pairs (*universal design*) and tapered roller bearing pairs in *X* or *O* arrangement may also be used as locating bearings.

## Locating/floating bearing arrangement

With this bearing arrangement the *locating bearing* guides the shaft axially in both directions; the *floating bearing* compensates for the heat expansion differential between shaft and housing. Shafts supported with more than two bearings are provided with only one *locating bearing*; all the other bearings must be *floating bearings*.

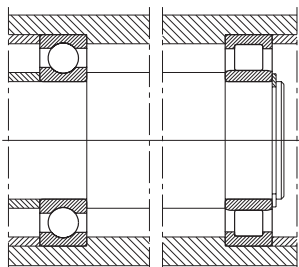

## Lubricating grease

Lubricating greases are consistent mixtures of *thickeners* and *base oils*. The following grease types are distinguished:

- metal soap base greases consisting of metal soaps as *thickeners* and *lubricating oils*,
- non-soap greases comprising inorganic gelling agents or organic *thickeners* and *lubricating oils*
- synthetic greases consisting of organic or inorganic *thickeners* and *synthetic oils*.

## Lubricating oil

Rolling bearings can be lubricated either with *mineral oils* or *synthetic oils*. Today, mineral oils are most frequently used.

## Lubrication interval

The lubrication interval corresponds to the minimum *grease service life* of standard greases (see FAG publication WL 81 115). This value is assumed if the grease service life for the grease used is not known.

## Machined/moulded cages

Machined *cages* of metal and textile laminated phenolic resin are produced in a cutting process. They are made from tubes of steel, light metal or textile laminated phenolic resin, or cast brass rings. Cages of polyamide 66 (*polyamide cages*) are manufactured by injection moulding. Like *pressed cages*, they are suitable for large-series bearings.

Machined cages of metal and textile laminated phenolic resin are mainly eligible for bearings of which only small series are produced. Large, heavily loaded bearings feature machined cages for strength reasons. Machined cages are also used where lip guidance of the cage is required. Lip-guided cages for high-speed bearings are often made of light materials, such as light metal or textile laminated phenolic resin to minimize the inertia forces.

## Mineral oils

Crude oils and/or their liquid derivatives.  
Cp. also *Synthetic lubricants*.

# Glossary

## Modified life

The standard Norm DIN ISO 281 introduced, in addition to the *nominal rating life*  $L_{10}$ , the *modified life*  $L_{na}$  to take into account, apart from the load, the influence of the failure probability (*factor*  $a_1$ ), of the material (*factor*  $a_2$ ) and of the operating conditions (*factor*  $a_3$ ).

DIN ISO 281 indicates no figures for the factor  $a_{23}$  ( $a_{23} = a_2 \cdot a_3$ ). With the FAG calculation process for the *attainable life* ( $L_{na}$ ,  $L_{hna}$ ), however, operating conditions can be expressed in terms of figures by the *factor*  $a_{23}$ .

## NLGI class

Cp. *Penetration*.

## Nominal rating life

The standardized calculation method for *dynamically stressed rolling bearings* is based on material fatigue (formation of pitting) as the cause of failure. The life formula is:

$$L_{10} = L = \left( \frac{C}{P} \right)^p \quad [10^6 \text{ revolutions}]$$

$L_{10}$  is the nominal rating life in millions of revolutions which is reached or exceeded by at least 90 % of a large group of identical bearings.

In the formula,

C *dynamic load rating* [kN]

P *equivalent dynamic load* [kN]

p *life exponent*

p = 3 for ball bearings

p = 10/3 for roller bearings and needle roller bearings.

Where the bearing speed is constant, the life can be expressed in hours.

$$L_{h10} = L_h = \frac{L \cdot 10^6}{n \cdot 60} \quad [\text{h}]$$

n speed [ $\text{min}^{-1}$ ]

$L_h$  can also be determined by means of the *index of dynamic stressing*  $f_L$ .

The nominal rating life L or  $L_h$  applies to bearings made of conventional rolling bearing steel and the usual operating conditions (good lubrication, no extreme temperatures, normal cleanliness).

The nominal rating life deviates more or less from the really *attainable life* of rolling bearings. Influences such as lubricating film thickness, cleanliness in the lubricating gap, lubricant *additives* and bearing type are taken into account in the *adjusted rating life calculation* by the *factor*  $a_{23}$ .

## O arrangement

In an O arrangement (*adjusted bearing mounting*) two *angular contact bearings* are mounted symmetrically in such a way that the *pressure cone apex* of the left-hand bearing points to the left and the *pressure cone apex* of the right-hand bearing points to the right.

With the O arrangement one of the bearing inner rings is adjusted. A bearing arrangement with a large *spread* is obtained which can accommodate a considerable tilting moment even with a short bearing distance. A suitable *fit* must be selected to ensure displaceability of the inner ring.

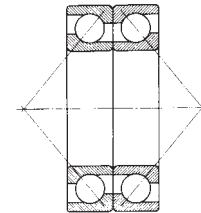

## Oil/oil lubrication

see *Lubricating oil*.

## Operating clearance

There is a distinction made between the *radial* or *axial clearance* of the bearing prior to mounting and the radial or axial clearance of the mounted bearing at operating temperature (operating clearance). Due to tight *fits* and temperature differences between inner and outer ring the operating clearance is usually smaller than the clearance of the unmounted bearing.

## Operating viscosity $\nu$

Kinematic *viscosity* of an oil at operating temperature. The operating viscosity  $\nu$  can be determined by means of a viscosity-temperature diagram if the viscosities at two temperatures are known. The operating viscosity of *mineral oils* with average *viscosity-temperature behaviour* can be determined by means of diagram 1 (page 185).

For evaluating the lubricating condition the *viscosity ratio*  $\kappa$  (*operating viscosity*  $\nu$  / *rated viscosity*  $\nu_1$ ) is formed when calculating the *attainable life*.

## Oscillating load

In selecting the *fits* for *radial bearings* and *angular contact bearings* the load conditions have to be considered. With relative oscillatory motion between the radial

# Glossary

load and the ring to be fitted, conditions of "oscillating load" occur. Both bearing rings must be given a tight *fit* to avoid sliding (cp. *circumferential load*).

## Penetration

Penetration is a measure of the *consistency* of a *lubricating grease*. Worked penetration is the penetration of a grease sample that has been worked, under exactly defined conditions, at 25 °C. Then the depth of penetration – in tenths of a millimetre – of a standard cone into a grease-filled vessel is measured.

Penetration of common rolling bearing greases

NLGI class (Penetration classes)	Worked penetration 0.1 mm
1	310...340
2	265...295
3	220...250
4	175...205

## Point load

In selecting the *fits* for the bearing rings of *radial bearings* and *angular contact bearings* the load conditions have to be considered. If the ring to be fitted and the radial load are stationary relative to each other, one point on the circumference of the ring is always subjected to the maximum load. This ring is point-loaded. Since, with point load, the risk of the ring sliding on its seat is minor, a tight fit is not absolutely necessary. With *circumferential load* or *oscillating load*, a tight *fit* is imperative.

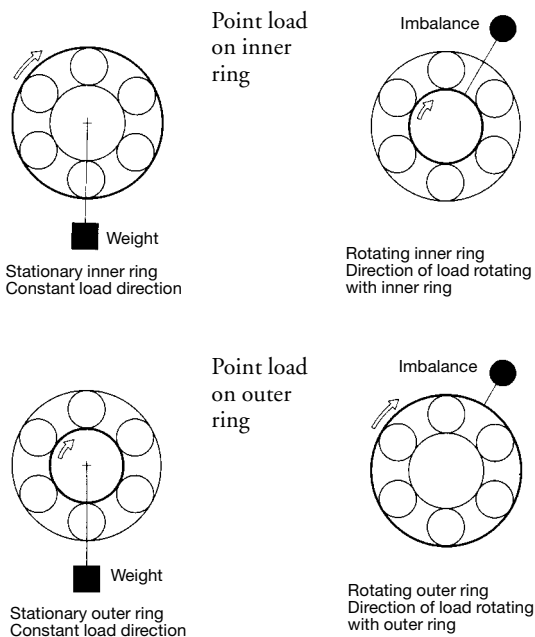

## Polyamide cage

Moulded cages of glass fibre reinforced polyamide PA66-GF25 are made by injection moulding and are used in numerous large-series bearings.

Injection moulding has made it possible to realize *cage* designs with an especially high load carrying capacity. The elasticity and low weight of the cages are of advantage where shock-type bearing loads, great accelerations and decelerations as well as tilting of the bearing rings relative to each other have to be accommodated. Polyamide cages feature very good sliding and dry running properties.

*Cages* of glass fibre reinforced polyamide 66 can be used at operating temperatures of up to 120 °C for extended periods of time. In *oil*-lubricated bearings, *additives* contained in the *oil* may reduce the *cage* life. At increased temperatures, aged oil may also have an impact on the cage life so that it is important to observe the oil change intervals.

## Precision bearings/precision design

In addition to bearings of normal precision (*tolerance class* PN), bearings of precision design (precision bearings) are produced for increased demands on working precision, speeds or quietness of running.

For these applications the tolerance classes P6, P6X, P5, P4 and P2 were standardized. In addition, some bearing types are also produced in the *tolerance classes* P4S, SP and UP in accordance with an FAG company standard.

## Pressed cage

Pressed cages are usually made of steel, but sometimes of brass, too. They are lighter than *machined* metal cages. Since a pressed cage barely closes the gap between inner ring and outer ring, *lubricating grease* can easily penetrate into the bearing. It is stored at the *cage*.

## Pressure cone apex

The pressure cone apex is that point on the bearing axis where the contact lines of an *angular contact bearing* intersect. The contact lines are the generatrices of the pressure cone.

In *angular contact bearings* the external forces act, not at the bearing centre, but at the pressure cone apex. This fact has to be taken into account when calculating the *equivalent dynamic load*  $P$  and the *equivalent static load*  $P_0$ .

---

# Glossary

---

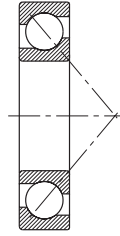

## Radial bearings

Radial bearings are those primarily designed to accommodate radial loads; they have a nominal *contact angle*  $\alpha_0 \leq 45^\circ$ . The *dynamic load rating* and the *static load rating* of radial bearings refer to pure radial loads (see *Thrust bearings*).

## Radial clearance

The radial clearance of a bearing is the total distance by which one bearing ring can be displaced in the radial plane, under zero measuring load. There is a difference between the radial clearance of the unmounted bearing and the radial *operating clearance* of the mounted bearing running at operating temperature.

## Radial clearance group

The *radial clearance* of a rolling bearing must be adapted to the conditions at the bearing location (*fits*, temperature gradient, speed). Therefore, rolling bearings are assembled into several radial clearance groups, each covering a certain range of radial clearance.

The radial clearance group CN (normal) is such that the bearing, under normal *fitting* and operating conditions, maintains an adequate *operating clearance*. The other clearance groups are:

- C2 radial clearance less than normal
- C3 radial clearance larger than normal
- C4 radial clearance larger than C3.

## Rated viscosity $\nu_1$

The rated *viscosity* is the kinematic *viscosity* attributed to a defined lubricating condition. It depends on the speed and can be determined with diagram 2 (page 185) by means of the mean bearing diameter and the bearing speed. The *viscosity ratio*  $\kappa$  (*operating viscosity*  $\nu$  / *rated viscosity*  $\nu_1$ ) allows the lubricating condition to be assessed (see also *factor*  $a_{23}$ ).

## Relubrication interval

Period after which the bearings are relubricated. The relubrication interval should be shorter than the *lubrication interval*.

## Rolling elements

This term is used collectively for balls, cylindrical rollers, barrel rollers, tapered rollers or needle rollers in rolling contact with the raceways.

## Seals/Sealing

On the one hand the sealing should prevent the lubricant (usually *lubricating grease* or *lubricating oil*) from escaping from the bearing and, on the other hand, prevent contaminants from entering into the bearing. It has a considerable influence on the *service life* of a bearing arrangement (cp. *Wear*, *Contamination factor V*). A distinction is made between non-rubbing seals (e.g. gap-type seals, labyrinth seals, shields) and rubbing seals (e.g. radial shaft seals, V-rings, felt rings, sealing washers).

## Self-aligning bearings

Self-aligning bearings are all bearing types capable of *self-alignment* during operation to compensate for *misalignment* as well as shaft and housing deflection.

These bearings have a spherical outer ring raceway. They are self-aligning ball bearings, barrel roller bearings, spherical roller bearings and spherical roller thrust bearings.

Thrust ball bearings with seating rings and S-type bearings are not self-aligning bearings because they can compensate for *misalignment* and deflections only during mounting and not in operation.

## Separable bearings

These are rolling bearings whose rings can be mounted separately. This is of advantage where both bearing rings require a tight *fit*.

Separable bearings include four-point bearings, cylindrical roller bearings, tapered roller bearings, thrust ball bearings, cylindrical roller thrust bearings and spherical roller thrust bearings.

Non-separable bearings include deep groove ball bearings, single-row angular contact ball bearings, self-

---

# Glossary

---

aligning ball bearings, barrel roller bearings and spherical roller bearings.

## Service life

This is the life during which the bearing operates reliably. The *fatigue life* of a bearing is the upper limit of its service life. Often this limit is not reached due to *wear* or lubrication breakdown (cpl. *Grease service life*).

## Speed factor $f_n$

The auxiliary quantity  $f_n$  is used, instead of the speed  $n$  [ $\text{min}^{-1}$ ], to determine the *index of dynamic stressing*,  $f_L$ .

$$f_n = \sqrt[p]{\frac{33^{1/3}}{n}}$$

$p = 3$  for ball bearings

$p = \frac{10}{3}$  for roller bearings and needle roller bearings

## Speed index $n \cdot d_m$

The product from the operating speed  $n$  [ $\text{min}^{-1}$ ] and the mean bearing diameter  $d_m$  [mm] is mainly used for selecting suitable lubricants and lubricating methods.

$$d_m = \frac{D + d}{2} \quad [\text{mm}]$$

D bearing outside diameter [mm]  
d bearing bore [mm]

## Speed suitability

Generally, the maximum attainable speed of rolling bearings is dictated by the permissible operating temperatures. This limiting criterion takes into account the *thermal reference speed*. It is determined on the basis of exactly defined, uniform criteria (reference conditions) in accordance with DIN 732, part 1 (draft). In catalogue WL 41 520 "FAG Rolling Bearings" a reference is made to a method based on DIN 732, part 2, for determining the *thermally permissible operating speed* on the basis of the *thermal reference speed* for cases where the operating conditions (load, oil viscosity or permissible temperature) deviate from the reference conditions.

The *kinematically permissible speed* is indicated also for bearings for which – according to DIN 732 – no thermal reference speed is defined, e. g. for bearings with rubbing *seals*.

## Spread

Generally, the spread of a machine component supported by two rolling bearings is the distance between the two bearing locations. While the distance between deep groove ball bearings etc. is measured between the bearing centres, the spread with single-row angular contact ball bearings and tapered roller bearings is the distance between the *pressure cone apices*.

## Static load/static stressing

Static stress refers to bearings carrying a load when stationary (no relative movement between the bearing rings).

The term "static", therefore, relates to the operation of the bearings but not to the effects of the load. The magnitude and direction of the load may change. Bearings which perform slow slewing motions or rotate at a low speed ( $n < 10 \text{ min}^{-1}$ ) are calculated like statically stressed bearings (cp. *Dynamic stressing*).

## Static load rating $C_0$

The static load rating  $C_0$  is that load acting on a stationary rolling bearing which causes, at the centre of the contact area between the most heavily loaded *rolling element* and the raceway, a total plastic deformation of about 1/10,000 of the *rolling element* diameter. For the normal curvature ratios this value corresponds to a Hertzian contact pressure of about 4,000 N/mm<sup>2</sup> for roller bearings, 4,600 N/mm<sup>2</sup> for self-aligning ball bearings and 4,200 N/mm<sup>2</sup> for all other ball bearings.  $C_0$  values, see FAG rolling bearing catalogues.

## Stress index $f_{s^*}$

In the *attainable life* calculation the stress index  $f_{s^*}$  represents the maximum compressive stress occurring in the rolling contact areas.

$$f_{s^*} = C_0/P_{0^*}$$

$C_0$  static load rating [kN]  
 $P_{0^*}$  equivalent bearing load [kN]  
 $P_{0^*} = X_0 \cdot F_r + Y_0 \cdot F_a$  [kN]  
 $F_r$  dynamic radial force [kN]  
 $F_a$  dynamic axial force [kN]  
 $X_0$  radial factor (see catalogue)  
 $Y_0$  thrust factor (see catalogue)

---

# Glossary

---

## Synthetic lubricants/synthetic oils

*Lubricating oils* produced by chemical synthesis; their properties can be adapted to meet special requirements: very low setting point, good *V-T behaviour*, small evaporation losses, long life, high oxidation stability.

## Tandem arrangement

A tandem arrangement consists of two or more *angular contact bearings* which are mounted adjacent to each other facing in the same direction, i.e. asymmetrically. In this way, the axial force is distributed over all bearings. An even distribution is achieved with universal-design *angular contact bearings*.

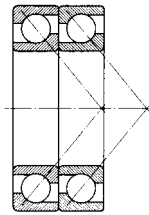

## Thermal reference speed

The thermal reference speed is a new index of the speed suitability of rolling bearings. In the draft of DIN 732, part 1, it is defined as the speed at which the reference temperature of 70 °C is established. In FAG catalogue WL 41 520 the standardized reference conditions are indicated which are similar to the normal operating conditions of the current rolling bearings (exceptions are, for example, spindle bearings, four-point bearings, barrel roller bearings, thrust ball bearings). Contrary to the past (limiting speeds), the thermal reference speed values indicated in the FAG catalogue WL 41 520 now apply equally to *oil* lubrication and *grease* lubrication.

For applications where the operating conditions deviate from the reference conditions, the *thermally permissible operating speed* is determined.

In cases where the limiting criterion for the attainable speed is not the permissible bearing temperature but, for example, the strength of the bearing components or the sliding velocity of rubbing *seals* the *kinematically permissible speed* has to be used instead of the thermal reference speed.

## Thermally permissible operating speed

For applications where the loads, the *oil viscosity* or the permissible temperature deviate from the reference conditions for the *thermal reference speed* the thermally permissible operating speed can be determined by means of diagrams.

The method is described in FAG catalogue WL 41 520.

## Thickener

*Thickener* and *base oil* are the constituents of *lubricating greases*. The most commonly used thickeners are metal soaps (e. g. lithium, calcium) as well as polyurea, PTFE and magnesium aluminium silicate compounds.

## Thrust bearings

Bearings designed to transmit pure or predominantly thrust loading, with a nominal *contact angle*  $\alpha_0 > 45^\circ$ , are referred to as thrust bearings.

The *dynamic load rating* and the *static load rating* of thrust bearings refer to pure thrust loads (cp. *Radial bearings*).

## Tolerance class

In addition to the standard tolerance (tolerance class PN) for rolling bearings there are also the tolerance classes P6, P6X, P5, P4 and P2 for *precision bearings*. The standard of precision increases with decreasing tolerance number (DIN 620).

In addition to the standardized tolerance classes FAG also produces rolling bearings in tolerance classes P4S, SP (super precision) and UP (ultra precision).

## Universal design

Special design of FAG angular contact ball bearings. The position of the ring faces relative to the raceway bottom is so closely toleranced that the bearings can be universally mounted without shims in *O*, *X* or *tandem arrangement*.

Bearings suffixed UA are matched together in such a way that unmounted bearing pairs in *O* or *X arrangement* have a small *axial clearance*. Under the same conditions, bearings suffixed UO feature zero *axial clearance*, and bearings suffixed UL a light preload. If the bearings are given tight *fits* the *axial clearance* of the bearing pair is reduced or the preload increased.

---

# Glossary

---

## Viscosity

Viscosity is the most important physical property of a *lubricating oil*. It determines the load carrying capacity of the oil film under elastohydrodynamic lubricating conditions. Viscosity decreases with rising temperature and vice-versa (see *V-T behaviour*). Therefore it is necessary to specify the temperature to which any given viscosity value applies. The nominal viscosity  $\nu_{40}$  of an oil is its kinematic viscosity at 40 °C.

SI units for the kinematic viscosity are  $\text{m}^2/\text{s}$  and  $\text{mm}^2/\text{s}$ . The formerly used unit Centistoke (cSt) corresponds to the SI unit  $\text{mm}^2/\text{s}$ . The dynamic viscosity is the product of the kinematic viscosity and the density of a fluid (density of *mineral oils*:  $0.9 \text{ g/cm}^3$  at 15 °C).

## Viscosity ratio $\kappa$

The viscosity ratio, being the quotient of the *operating viscosity*  $\nu$  and the *rated viscosity*  $\nu_1$ , is a measure of the lubricating film development in a bearing, cp. *factor*  $a_{23}$ .

## Viscosity-temperature behaviour (V-T behaviour)

The term V-T behaviour refers to the *viscosity* variations in *lubricating oils* with temperature. The V-T behaviour is good if the viscosity varies little with changing temperatures.

## Wear

The life of rolling bearings can be terminated, apart from fatigue, as a result of wear. The clearance of a worn bearing gets too large.

One frequent cause of wear are foreign particles which penetrate into a bearing due to insufficient *sealing* and have an abrasive effect. Wear is also caused by starved lubrication and when the lubricant is used up.

Therefore, wear can be considerably reduced by providing good lubrication conditions (*viscosity ratio*  $\kappa > 2$  if possible) and a good degree of cleanliness in the rolling bearing. Where  $\kappa \leq 0.4$  wear will dominate in the bearing if it is not prevented by suitable *additives* (*EP additives*).

## X arrangement

In an X arrangement, two *angular contact bearings* are mounted symmetrically in such a way that the *pressure cone apex* of the left-hand bearing points to the right and that of the right-hand bearing points to the left.



With an X arrangement, the bearing clearance is obtained by *adjusting* one outer ring. This ring should be subjected to *point load* because, being displaceable, it cannot be fitted tightly (*Fits*). Therefore, an X arrangement is provided where the outer ring is subjected to *point load* or where it is easier to adjust the outer ring than the inner ring. The effective bearing *spread* in an X arrangement is less than in an *O arrangement*.

---

## Notes

---

---

## Notes

---

---

---

## The Design of Rolling Bearing Mountings

Every care has been taken to ensure the correctness of the information contained in this publication but no liability can be accepted for any errors or omissions. We reserve the right to make changes in the interest of technical progress.

© by FAG 1998. This publication or parts thereof may not be reproduced without our permission.

WL 00 200/5 EC/98,5/4/98

Printed in Germany by Weppert GmbH & Co. KG, Schweinfurt