

WIRING DIAGRAM

Panasert

JV, JV (LL)

NM- 2034

NM- 2035

Panasonic

Doc.	2 0 3 4
No.	C 0 5 6 B E
	Q 1 3 0 0 0 5 E 1

Commercial Reference	Sym.	Date	Revision	Signed

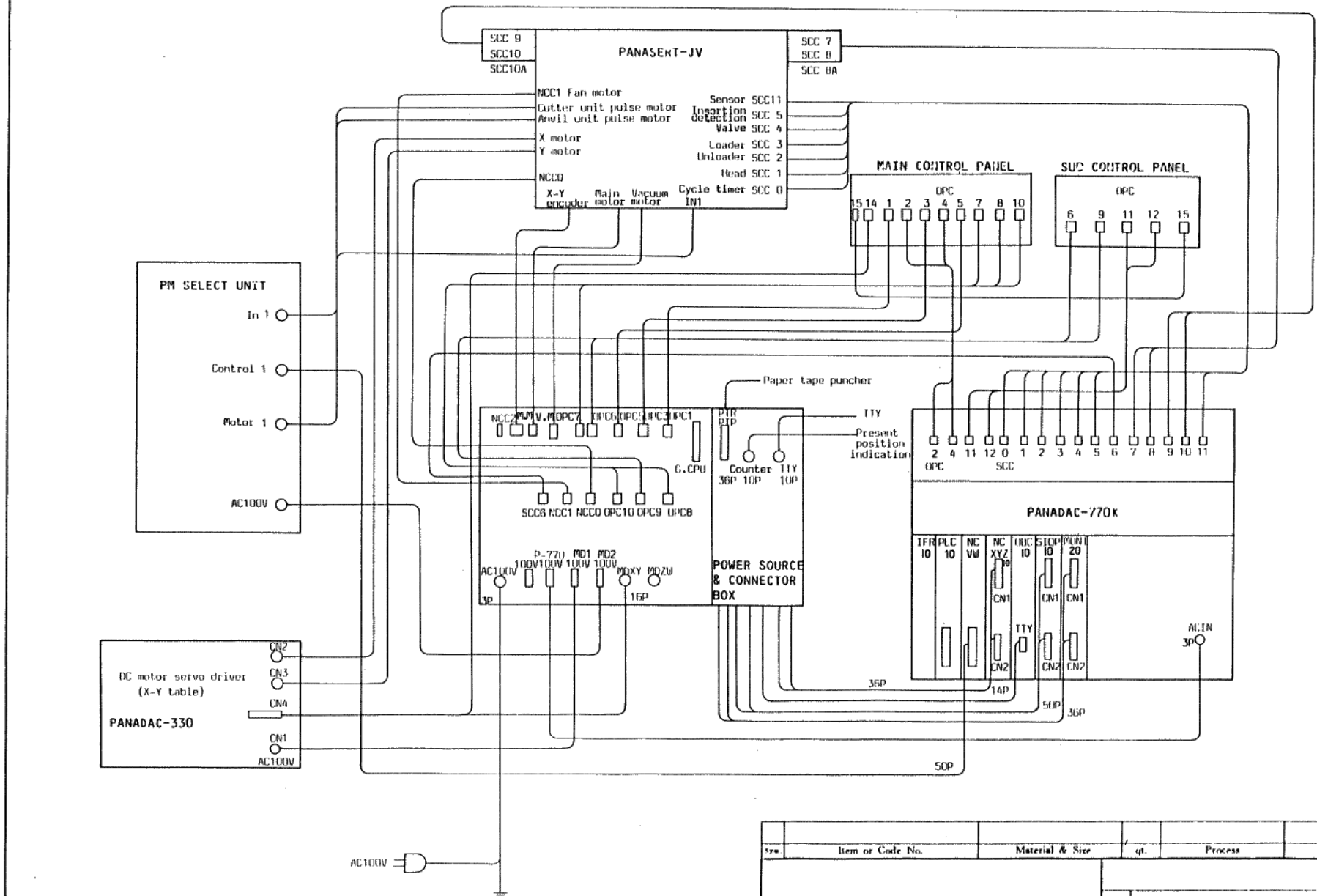

Qty	Item or Code No.	Material & Size	qt.	Process	Remark

Name: GENERAL WIRING

No. M 1 0 1 0 5 - 9 0 - 0 0 0

Emmarral	Sym.	Date	Revision	Signed	Ch

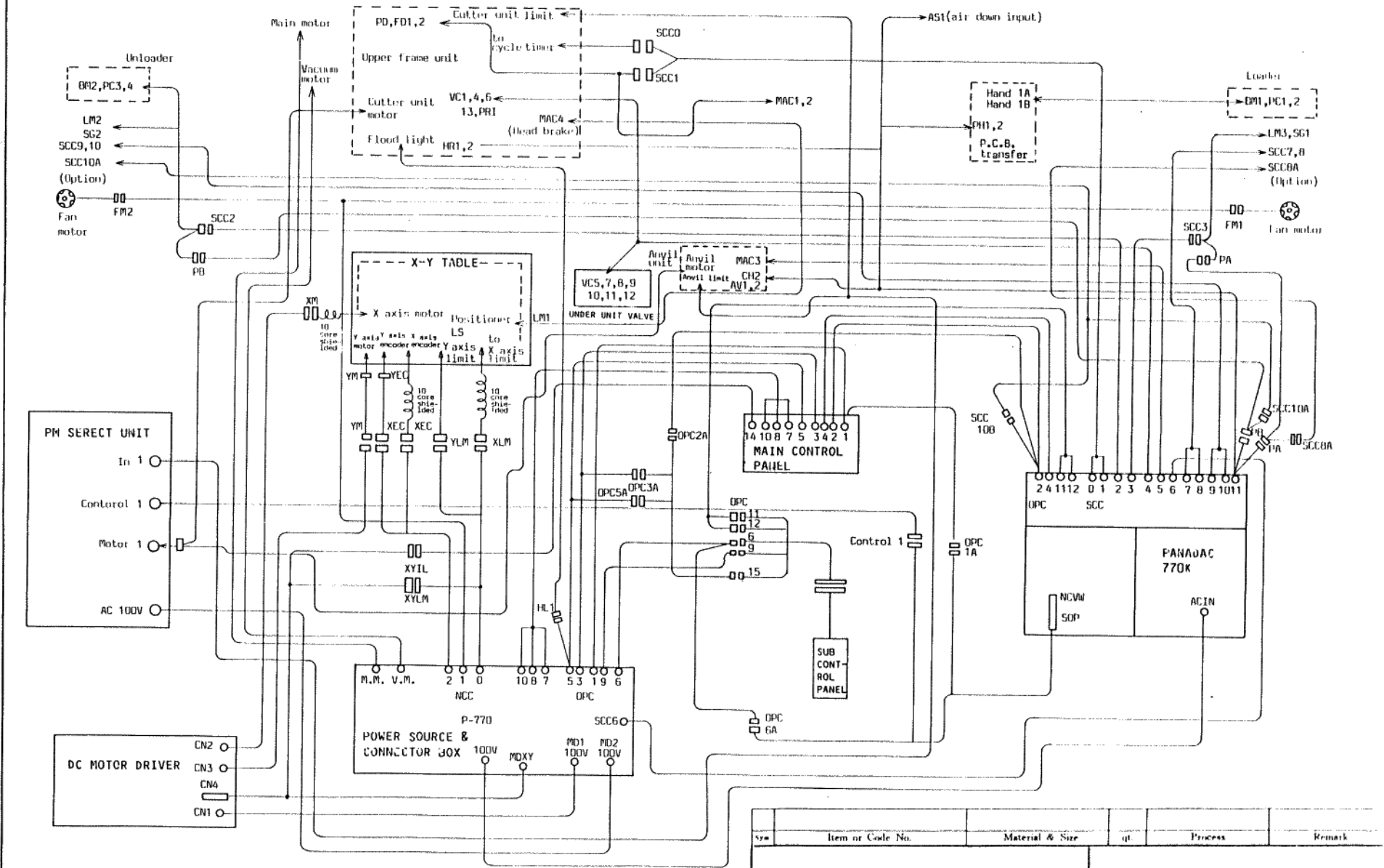

Sym	Item or Code No.	Material & Size	qt.	Process	Remark
Name: GENERAL WIRING (DETAIL DIAGRAM)					
Scale	Revised	Checked	Drawn	Approved	Project

1010590001

Commercial Tolerance	Sym.	Date	Revision	Signed	Chk
	△				

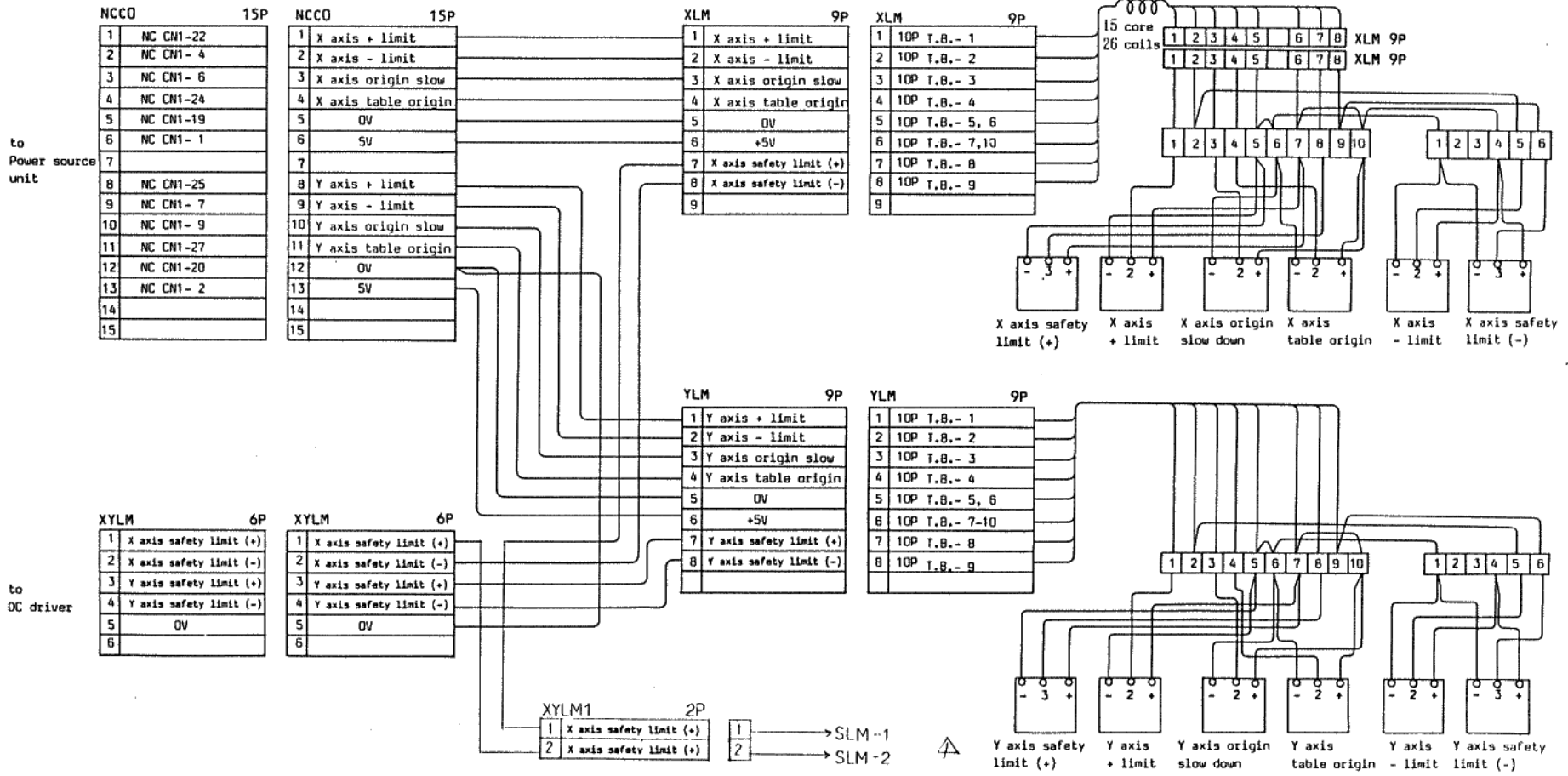

Item or Code No.	Material & Size	qt.	Process	Remark
Name: X-Y TABLE WIRING (NCCO)				
No. M 1 0 1 0 5 - 9 0 - 0 0 2				

Commercial Tolerance	Sym.	Date	Revision	Signed	Chk

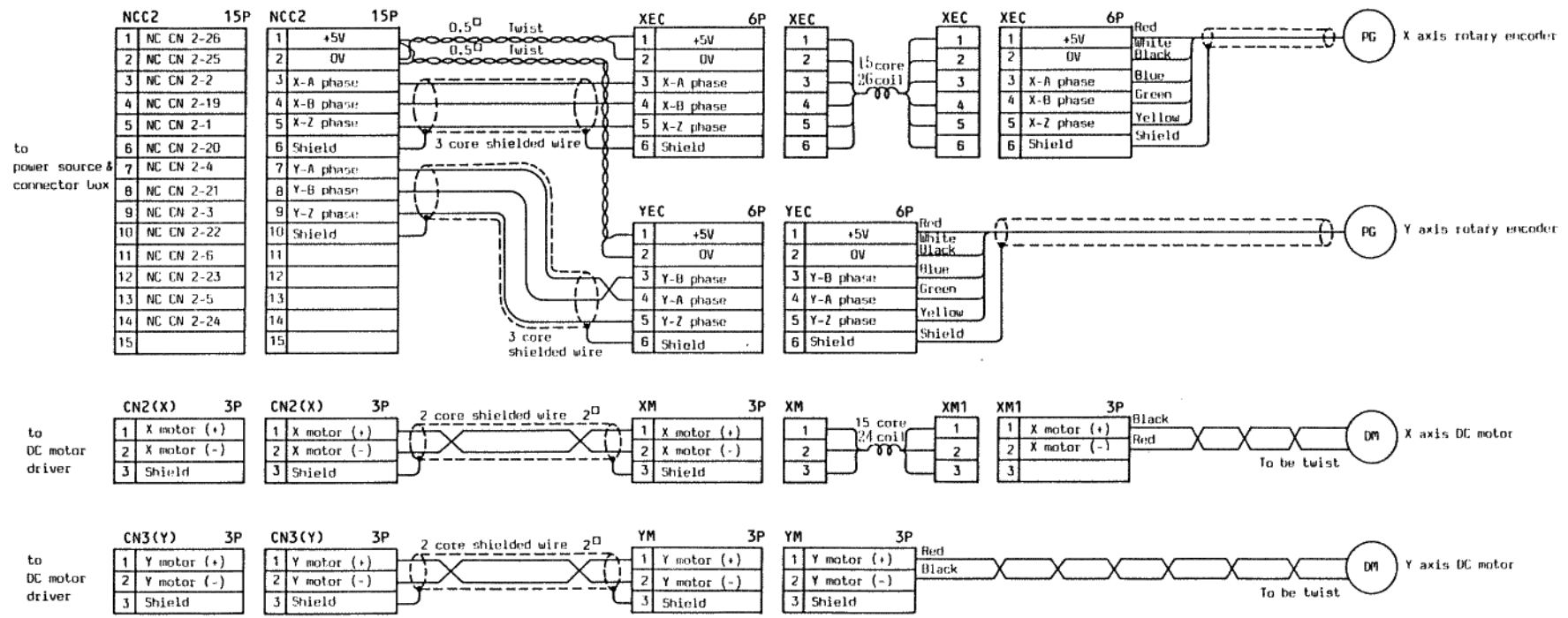

Sym.	Item or Code No.	Material & Size	qt.	Process	Remark
					(NCC2)
					DC MOTOR, ROTARY ENCODER WIRING
					No. M 1 0 1 0 5 - 9 0 - 0 0 3

Commercial Reference	Sym.	Date	Revision	Signed	Chr.

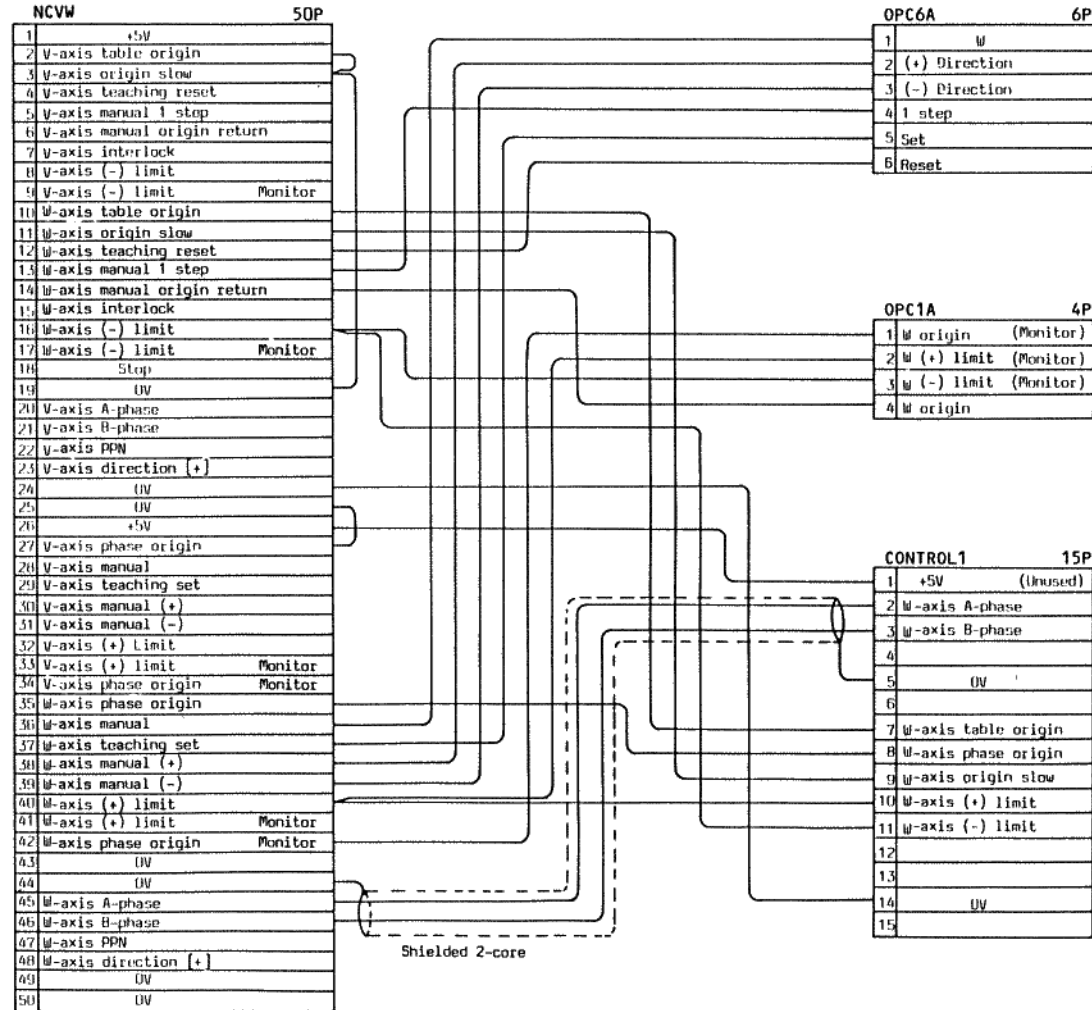

Qty	Item or Code No.	Material & Size	qt.	Process	Remark

Scale	1/4"	1/2"	3/4"	1"	1 1/2"	2"	3"	4"	5"	6"	8"	10"	12"	15"	20"	25"	30"	36"	48"	60"	72"	96"	120"
Designed	Checked	Drawn	Traced	Entered	Reviewed	Name: VARIABLE MOTOR WIRING 1																	
No. M10105-90-005-																							

Commercial Tolerance	Sym.	Date	Revision	Signed	CS

Spiral code color instruction

- 1 - Brown, Red, Orange
- 2 - Yellow, Green, Blue
- 3 - Violet, Gray, White
- 4 - Black, Brown/White, Red/White
- 5 - Orange/White, Yellow/White, Green/White

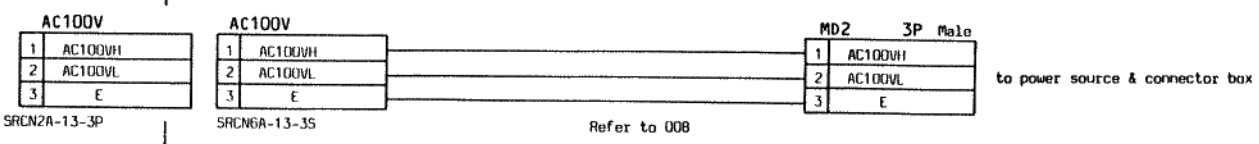
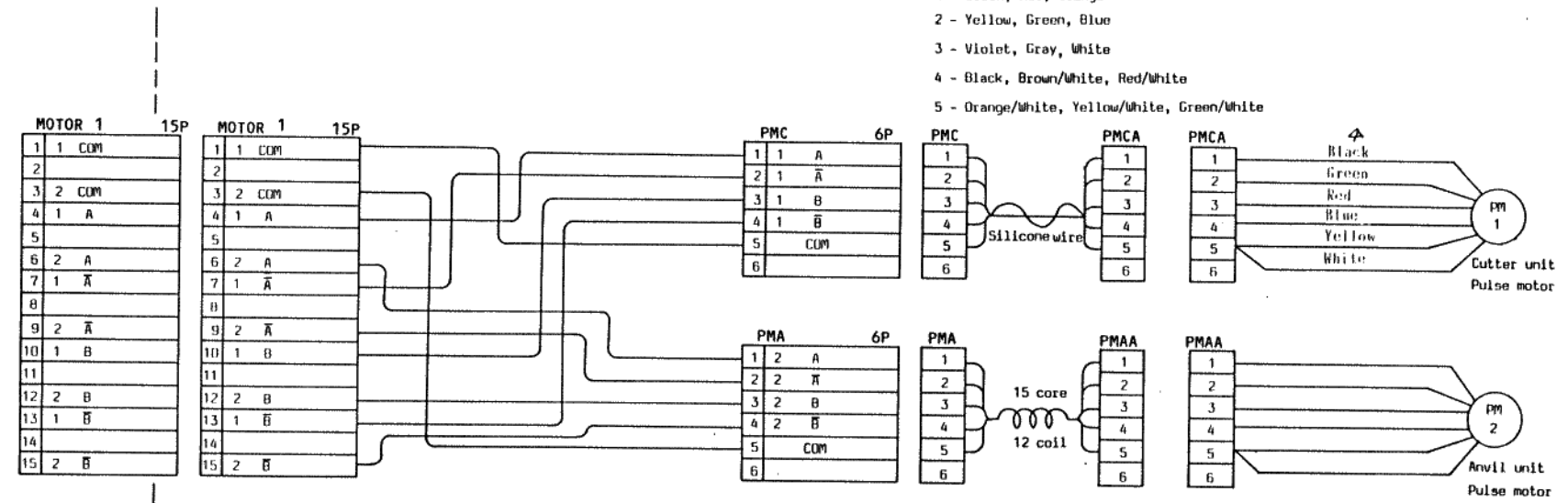

Qty	Item or Code No.	Material & Size	qt.	Process	Remark
					Name
					VARIABLE MOTOR WIRING 2
					No.
					M 1 0 1 0 5 - 9 0 - 0 0 6 -

Commercial Tolerance	Sym.	Date	Revision	Signed	Or

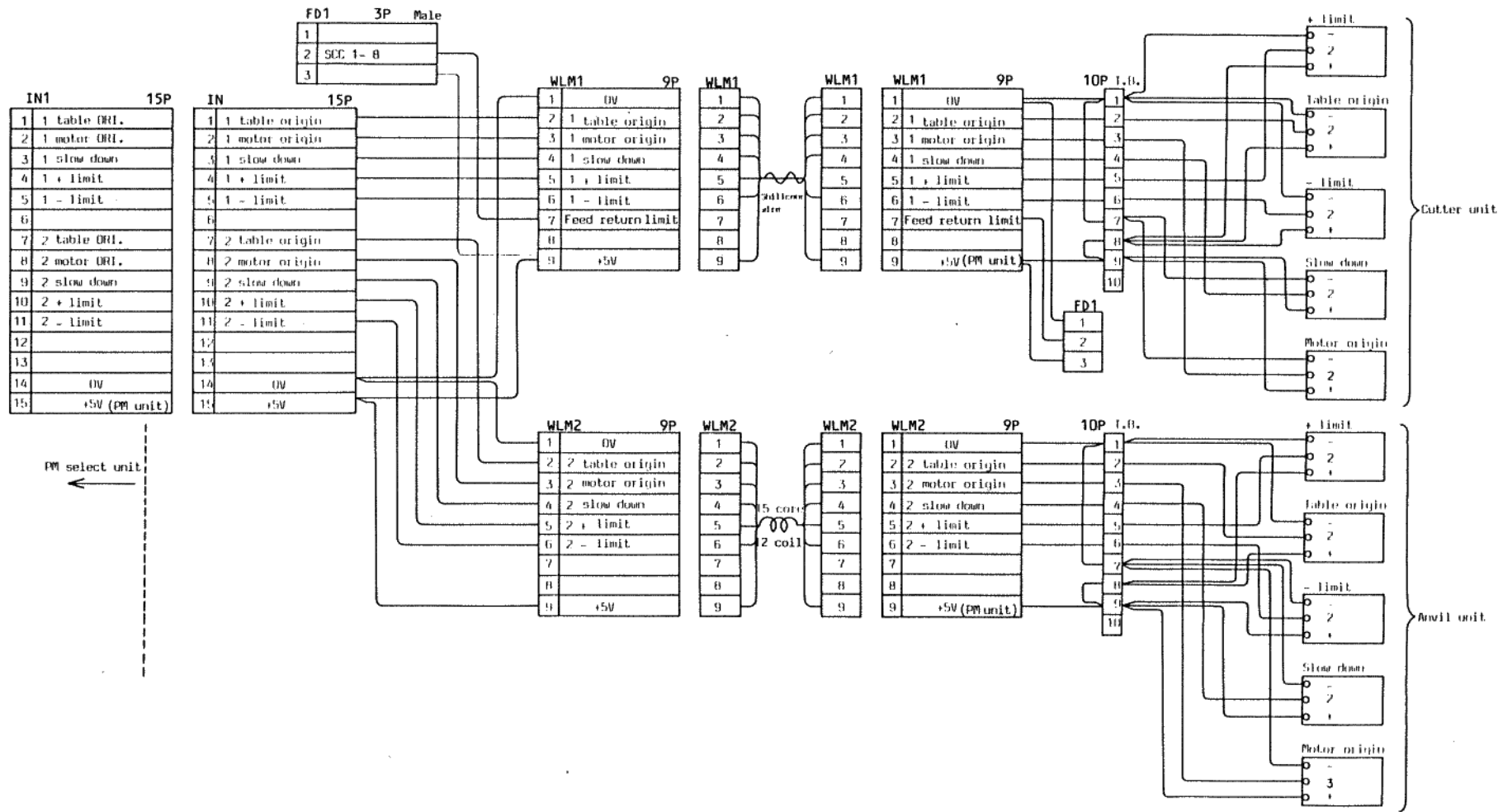

※PHOTO-SW [EHU-01MS013]

Size	Item or Code No.	Material & Size	qt.	Process	Remark

Name		(IN 1)	
CUTTER-ANVIL UNIT LIMIT WIRING			
No.	M 1 0 1 0 5 - 9 0 - 0 0 7		

Commercial Tolerance	Sym.	Date	Revision	Signed	Chk.

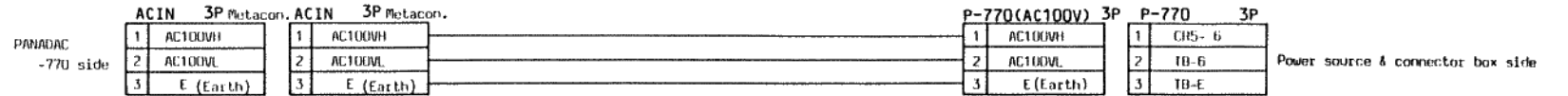
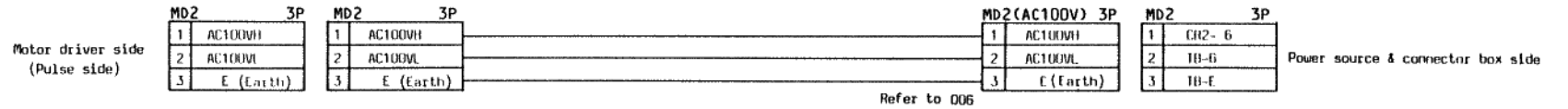
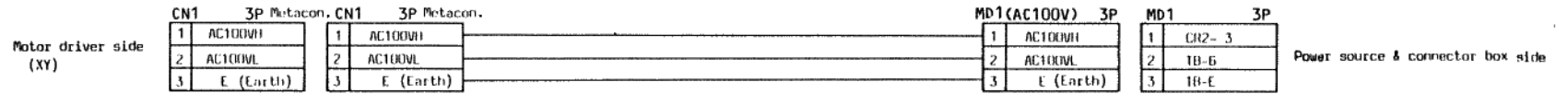

Qty	Item or Code No.	Material & Size	qt.	Process	Remark
					Name POWER WIRING
					No. M 1 0 1 0 5 - 9 0 - 0 0 8 -

Commercial Entered	Sym.	Date	Revision	Signed	chk

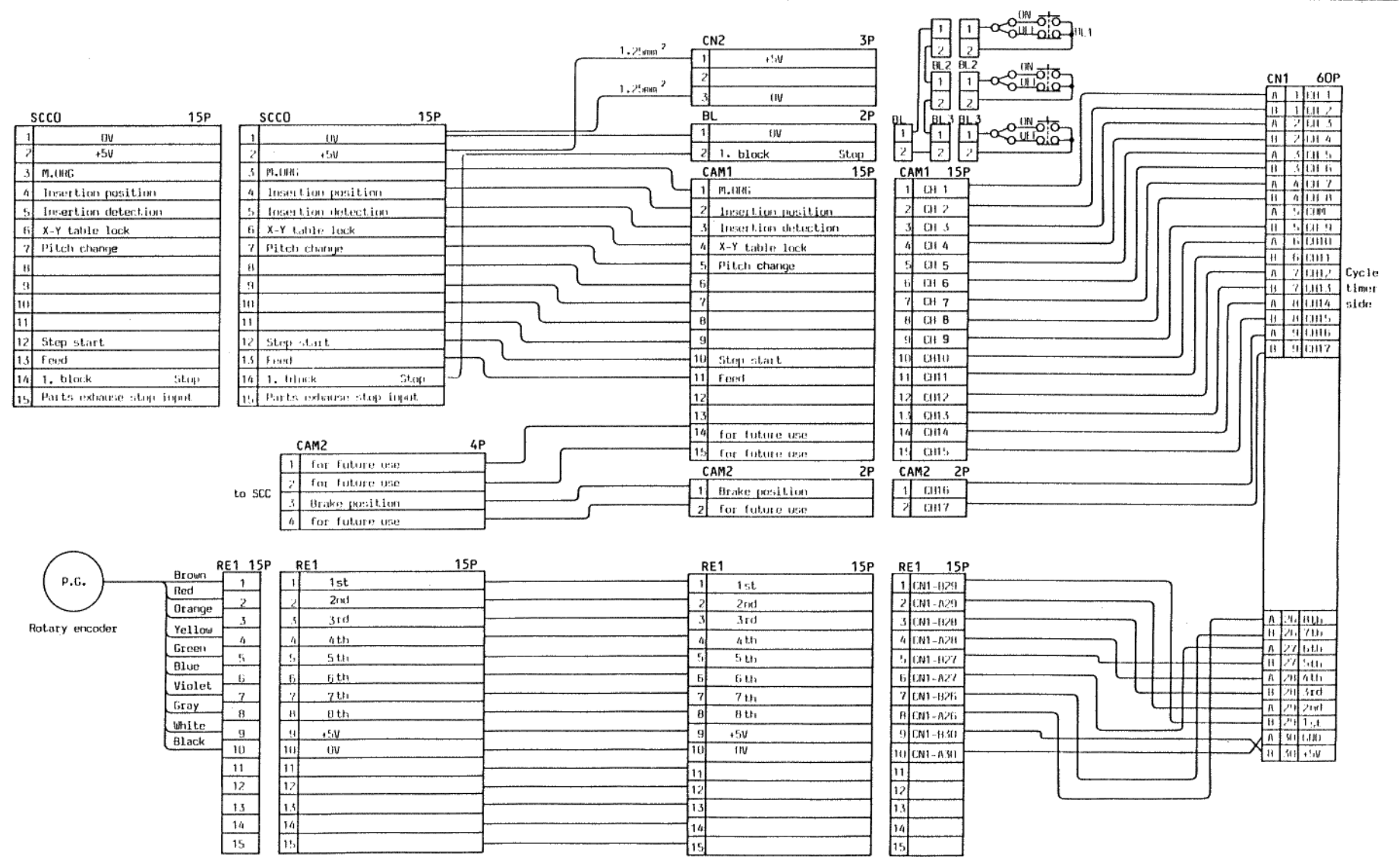

Cycle timer
 M.origin (340°-210°)
 Insertion position (170°-210°)
 Insertion detection (280°-320°)
 X-Y table lock (210°-330°)
 Pitch change (310°-190°)
 Step start (320°-340°)
 Feed (40°-190°)
 Brake position (150°-180°)

Qty	Item or Code No.	Material & Size	qt.	Process	Remark

Scale	Designed	Checked	Drawn	Traced	Checked	Approved

Name	CYCLE TIMER WIRING				
No.	M 1 0 1 0 5 - 9 0 - 0 0 9				

SCCO	15P
1	Power source & connector box unit 1.B. 01
2	Power source & connector box unit 1.B. 5V
3	I/O4-A2
4	I/O4-A3
5	I/O4-A4
6	I/O4-A5
7	I/O4-A6
8	I/O4-A7
9	I/O4-A8
10	For future use
11	I/O4-B1
12	I/O4-B2
13	I/O4-B3
14	I/O4-B4
15	I/O4-B5

SCCO	15P
1	
2	
3	
4	
5	
6	
7	
8	
9	
10	
11	
12	
13	
14	
15	

SCCO	15P
1	0V
2	+5V
3	M.ORG
4	Insertion position
5	Insertion detection
6	X-Y table lock
7	Pitch change
8	P.C.B detection 5
9	
10	
11	
12	Step start
13	Feed
14	1. Block stop
15	Parts exhaust stop input

PF1	3P
1	0V
2	PRE Feed traverse limit (LS)
3	5V

PF2	3P
1	0V
2	PRE Feed return limit (LS)
3	5V

CAM2	4P
1	For future use
2	For future use
3	Brake position
4	

SCC1	15P
1	I/O4-B6
2	I/O4-B7
3	I/O4-B8
4	For future use
5	I/O5-A22
6	SCC1-5
7	I/O5-B12
8	I/O5-B20
9	I/O5-B21
10	I/O5-A16
11	I/O3-A2
12	
13	TB-7
14	I/O7-B1,2
15	I/O7-B3,4

SCC1	15P
1	
2	
3	
4	
5	
6	
7	
8	
9	
10	
11	
12	
13	
14	
15	

SCC1	15P
1	PRE Feed traverse limit (LS)
2	PRE Feed return limit (LS)
3	Brake position
4	
5	0V
6	0V
7	+5V
8	Feed return limit (LS)
9	Feed traverse limit (LS)
10	Parts detection
11	
12	
13	+24V
14	Main clutch
15	Main brake 1

SLM	15P
10	0V
11	safety LS In Pot.

PC	2P
1	0V
2	12V

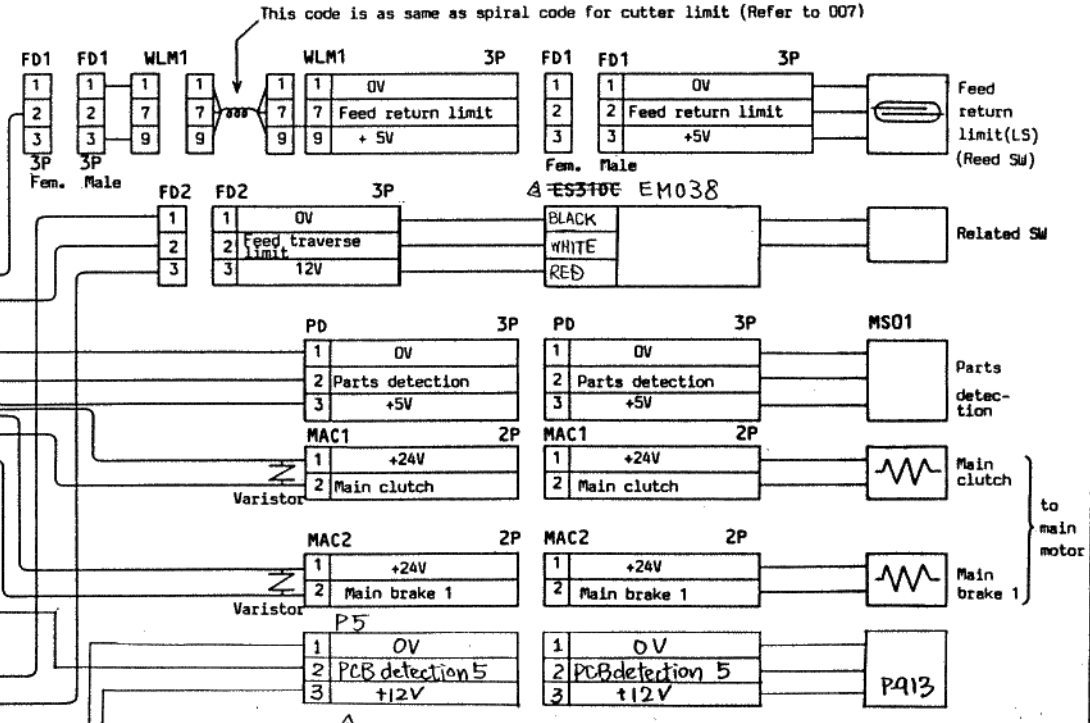

Item or Code No.	Material & Size	qt.	Process	Remark														
<table border="1"> <tr> <td>Scale</td> <td>Designed</td> <td>Checked</td> <td>Drawn</td> <td>Trace</td> <td>Checked</td> <td>Approved</td> </tr> <tr> <td></td> <td></td> <td></td> <td></td> <td></td> <td></td> <td></td> </tr> </table>					Scale	Designed	Checked	Drawn	Trace	Checked	Approved							
Scale	Designed	Checked	Drawn	Trace	Checked	Approved												
<table border="1"> <tr> <td>Name</td> <td colspan="4">TIMING CAM INSERTION HEAD WIRING (SCCO)</td> </tr> <tr> <td>No.</td> <td colspan="4">M 1 0 1 0 5 - 9 0 - 0 1 0</td> </tr> </table>					Name	TIMING CAM INSERTION HEAD WIRING (SCCO)				No.	M 1 0 1 0 5 - 9 0 - 0 1 0							
Name	TIMING CAM INSERTION HEAD WIRING (SCCO)																	
No.	M 1 0 1 0 5 - 9 0 - 0 1 0																	

Commercial Tolerance	Sym.	Date	Revision	Signed	CS

SCC2	15P
1	TB-1
2	I/O9-B15,16
3	I/O5-A 6
4	I/O5-A 7
5	I/O5-B 4
6	I/O5-B 5
7	I/O5-A20
8	I/O5-A21
9	I/O5-A10
10	SCC2- 9
11	SCC2-10
12	I/O1-B 6
13	I/O5-A19
14	I/O1-B 8
15	

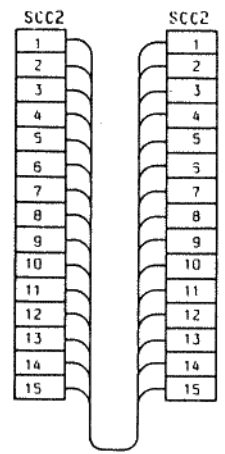

SCC2	15P
1	AC100VH
2	UL.Belt motor
3	U.rail traverse limit
4	U.rail return limit
5	P.C.B detection 3
6	P.C.B detection 4
7	Push arm/push up traverse limit
8	Push arm/push up return limit
9	0V
10	0V
11	0V
12	Stocker rotation signal
13	Stocker ready signal
14	Push arm signal
15	

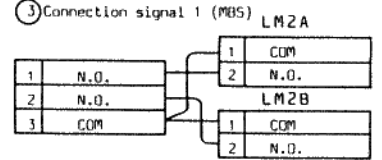
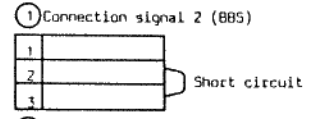
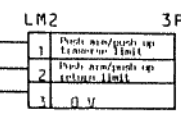
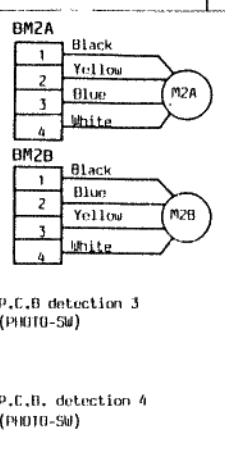
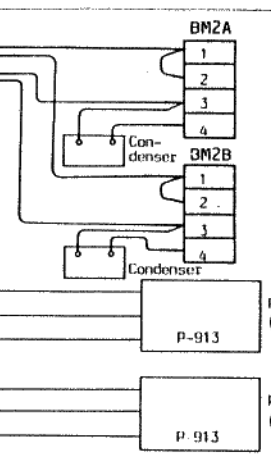
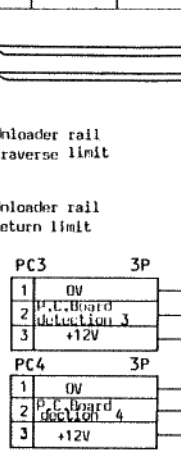
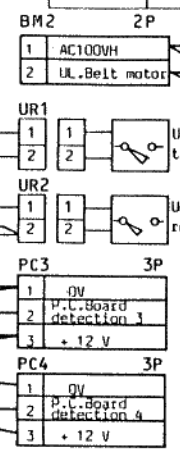
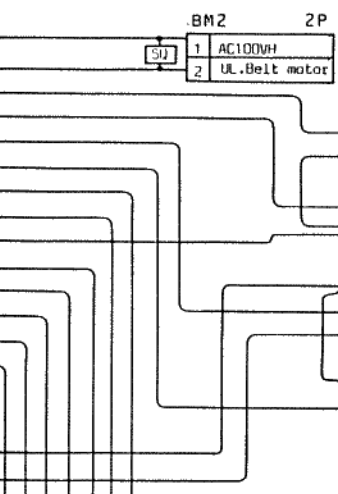

④ Don't use when BBS (Keep open)

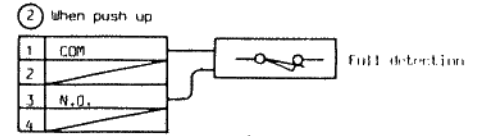
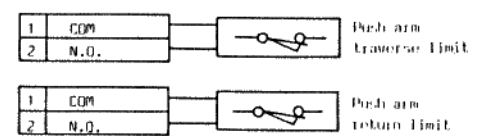
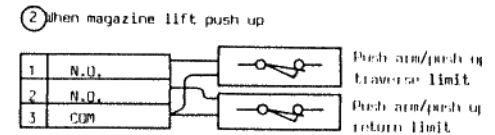
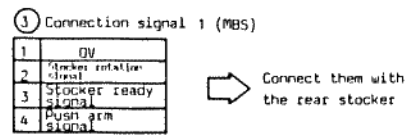
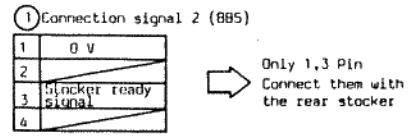
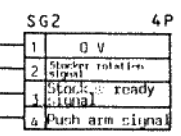

④ MBS,BBS Not use (Open)

Qty	Item or Code No.	Material & Size	qt.	Process	Remark

Name: UNLOADER WIRING (SCC2)

No. M 1 0 1 0 5 - 9 0 - 0 1 1

Commercial Reference	Sym.	Date	Revision	Signed	Chk

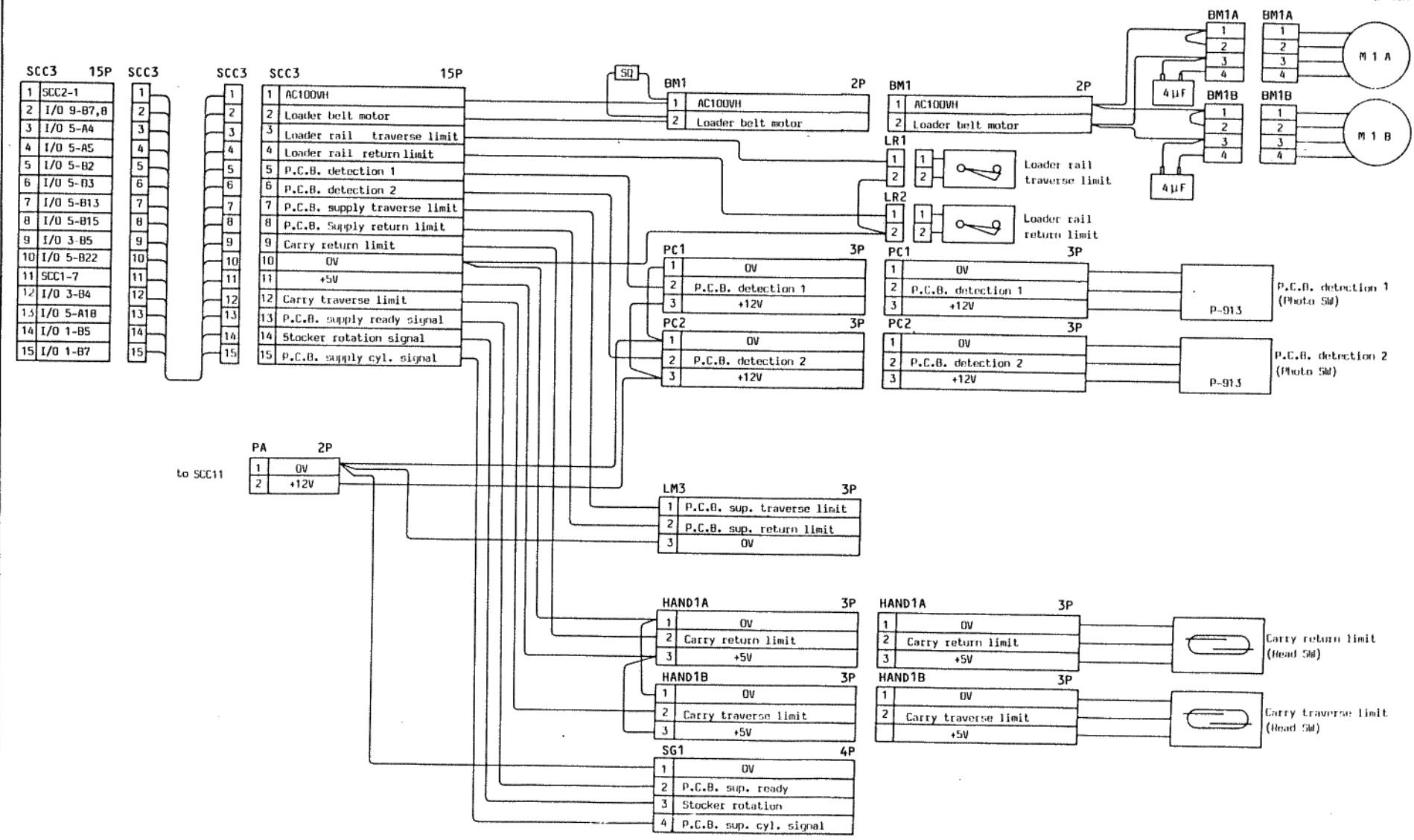

Qty	Item or Code No.	Material & Size	qt.	Process	Remark
Name: LOADER WIRING (SCC3)					
No. M 1 0 1 0 5 - 9 0 - 0 1 2					

Scale: _____
 Designed: _____
 Drawn: _____
 Checked: _____
 Approved: _____

Symbol	Date	Revision	Signed
A	11.14	for Europe safety	

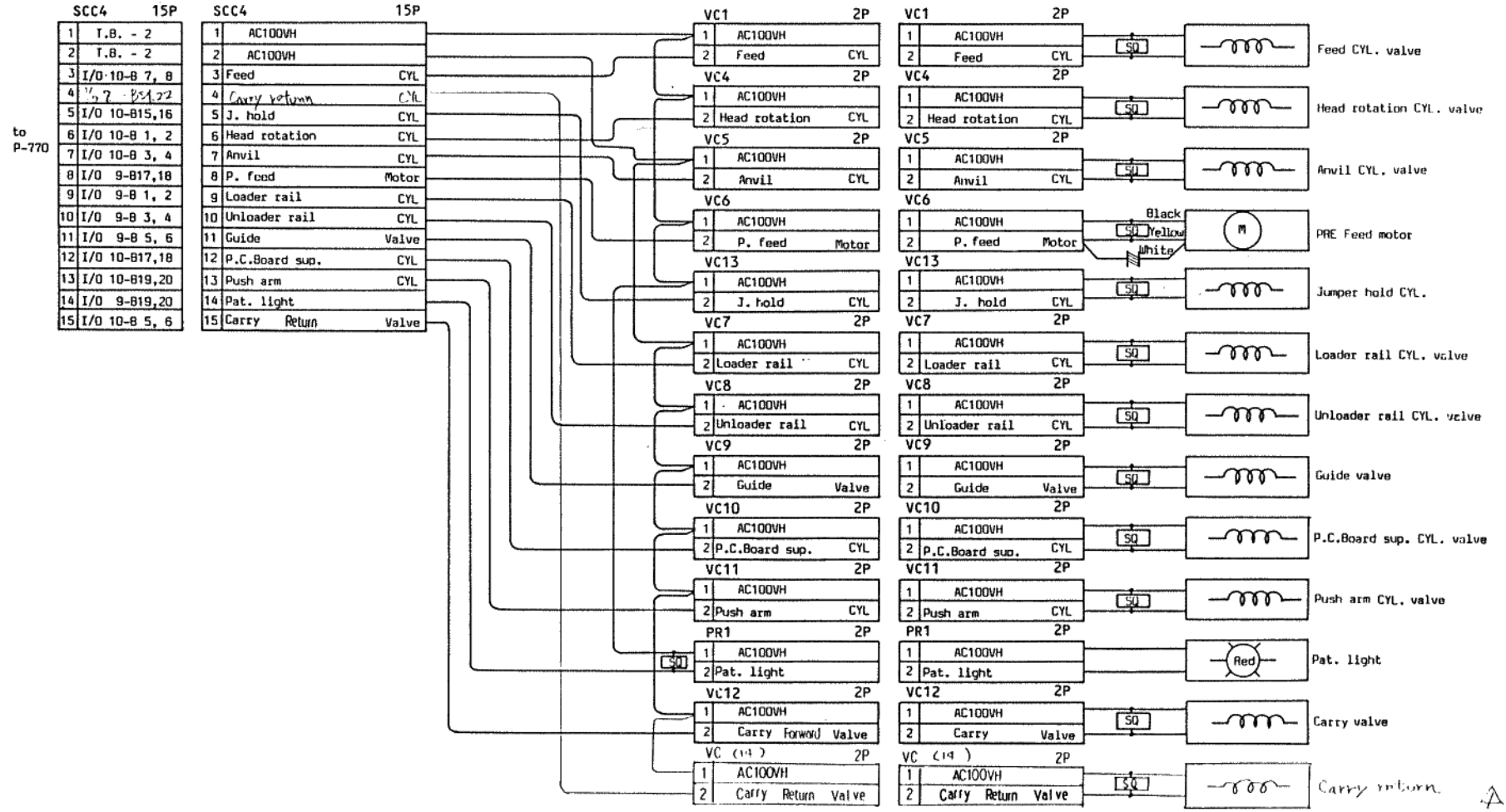

Item or Code No.	Material & Size	qt.	Process	Remark
Name SOLENOID WIRING (SCC4)				
No. M 1 0 1 0 5 - 9 0 - 0 1 3 -				

Commercial Tolerance	Sym.	Date	Revision	Signed

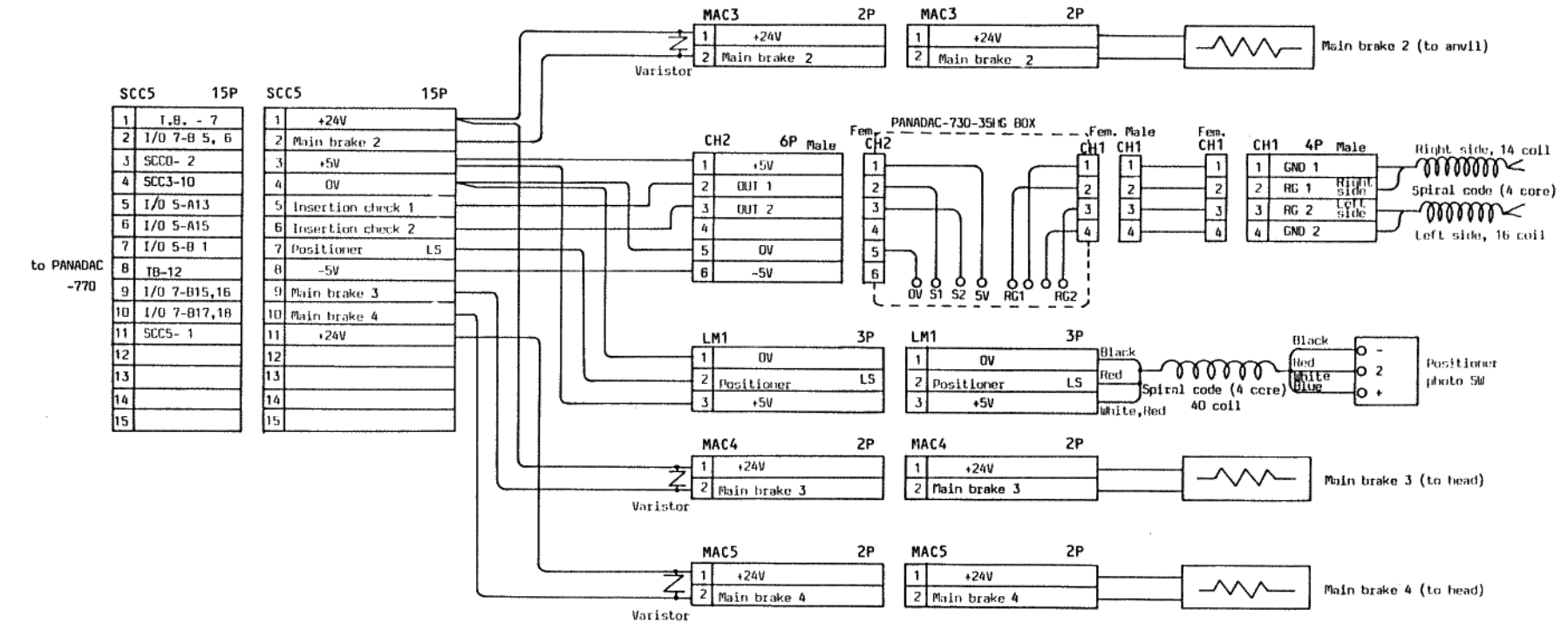

Item or Code No.	Material & Size	qt.	Process	Remark
Name: INSERTION DETECTION WIRING (SCC5)				
No. M 1 0 1 0 5 - 9 0 - 0 1 4 -				

Commercial Tolerance	Sym.	Date	Revision	Signed	Ch

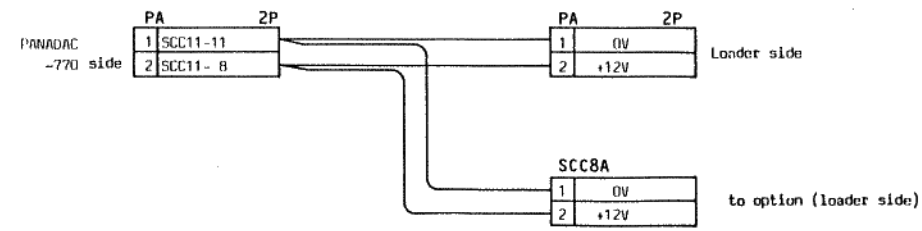
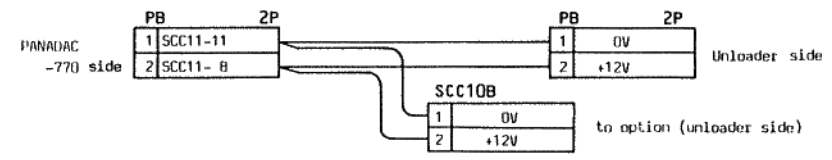
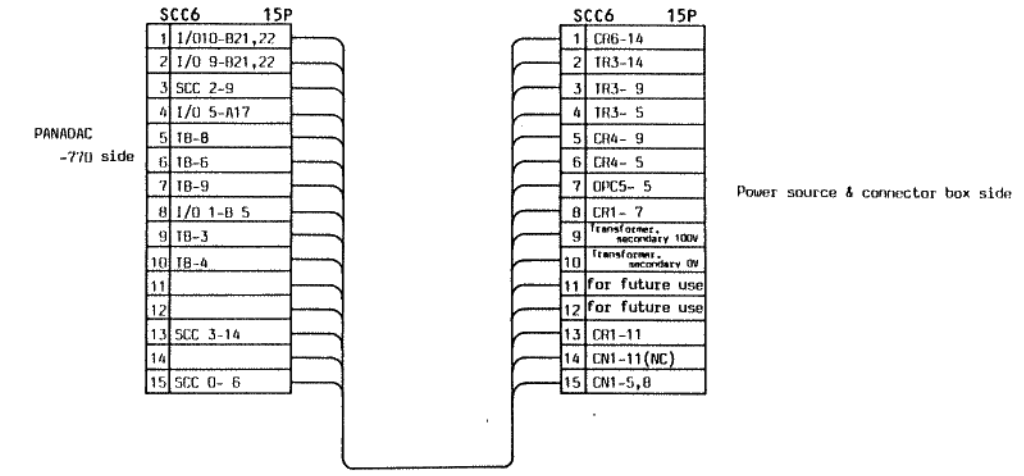

Item or Code No.	Material & Size	qt.	Process	Remark
Name (SCC6, PA, PB) WIRING				
No. M 1 0 1 0 5 - 9 0 - 0 1 5 -				

Commercial Tolerance	Sym.	Date	Revision	Signed	Ch

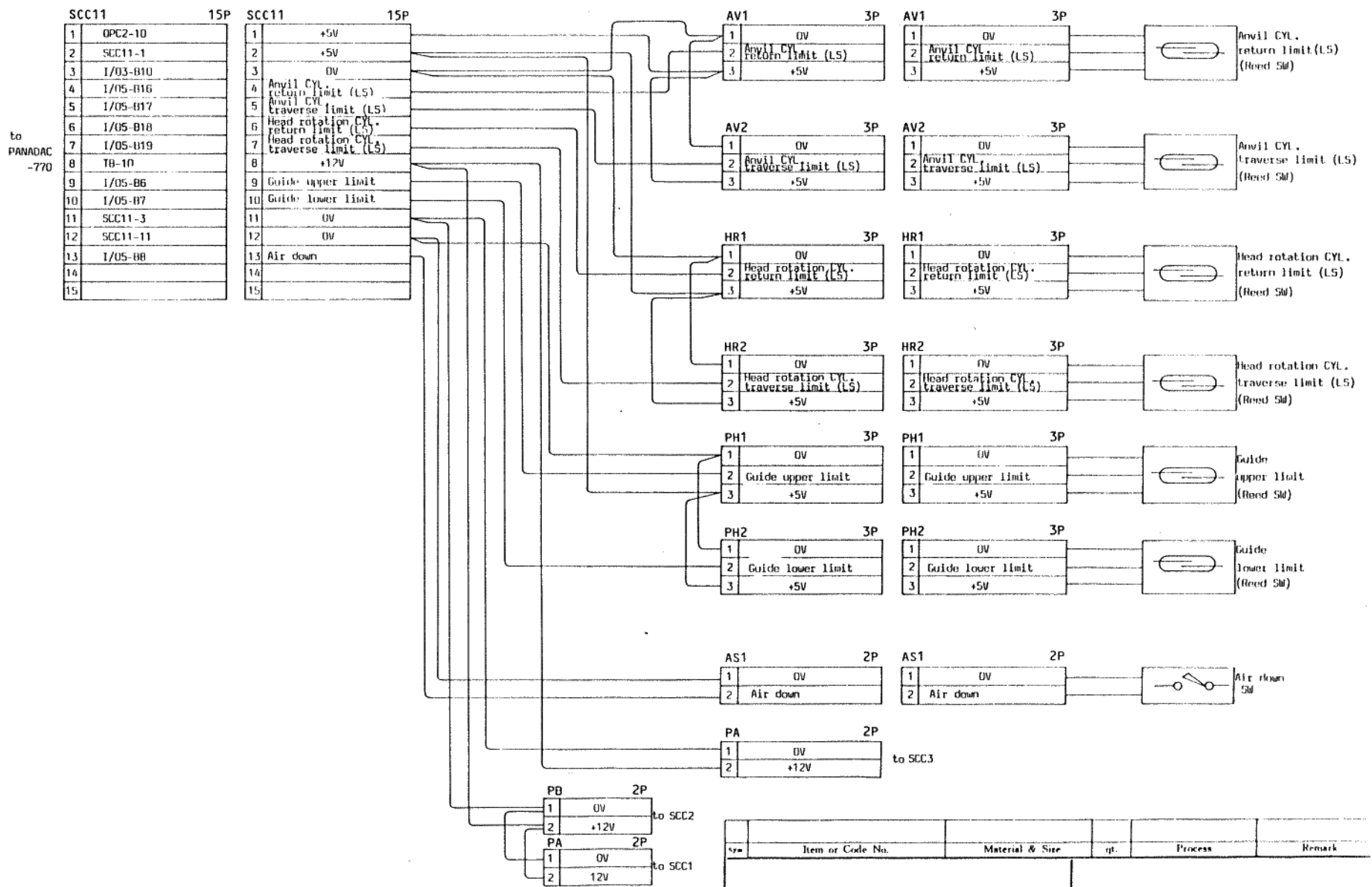

Item or Code No.	Material & Size	qt.	Process	Remark

Scale	Designed	Drawn	Traced	Checked	Approved	Name	ANVIL-HEAD WIRING (SCC11)
						No.	M 1 0 1 0 5 - 9 0 - 0 1 8

Commercial Tolerance	Sym.	Date	Revision	Signed	chk

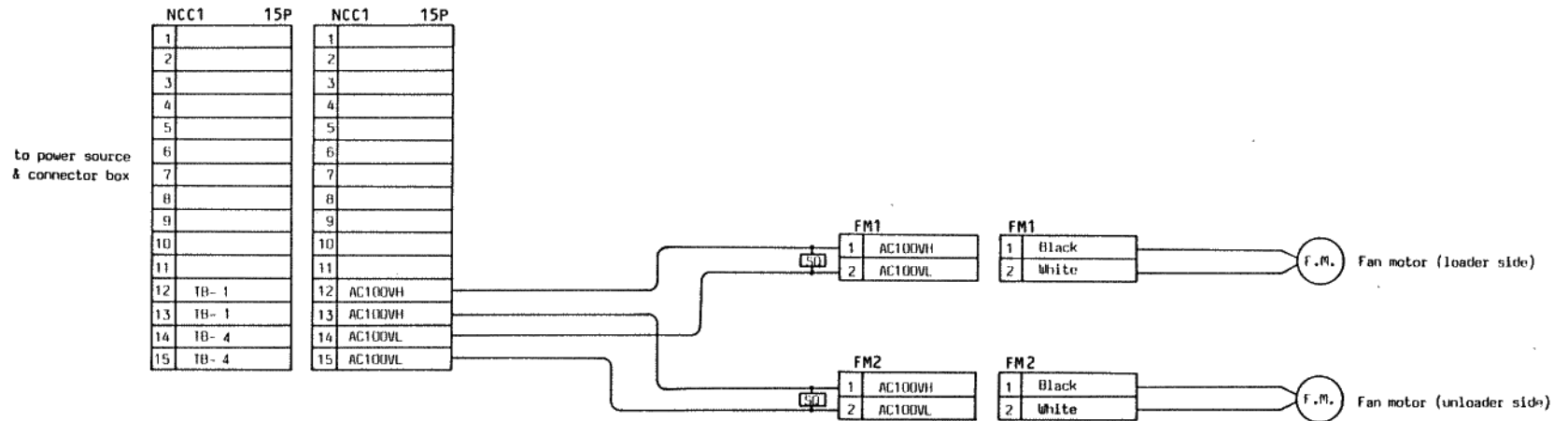

Qty.	Item or Code No.	Material & Size	qt.	Process	Remark

Scale	Designed	Drawn	Traced	Checked	Approved	Name	FAN MOTOR WIRING (NCC1)
						No.	M10105-90-019

Commercial Tolerance	Sym.	Date	Revision	Signed	Chk.

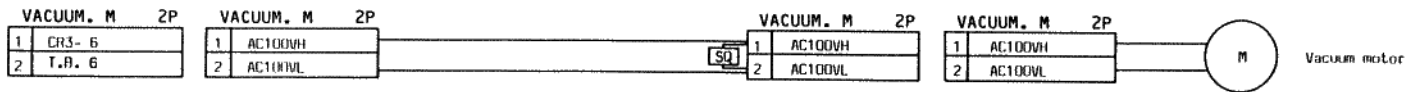
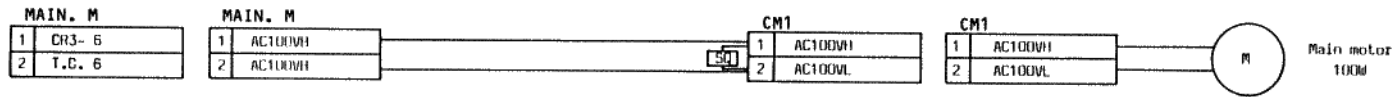

Qty	Item or Code No.	Material & Size	qt.	Process	Remark
					Name MAIN VACUUM) MOTOR WIRING
					No. M 1 0 1 0 5 - 9 0 - 0 2 0 -

Commercial Reference	Sym.	Date	Revision	Signed	CS

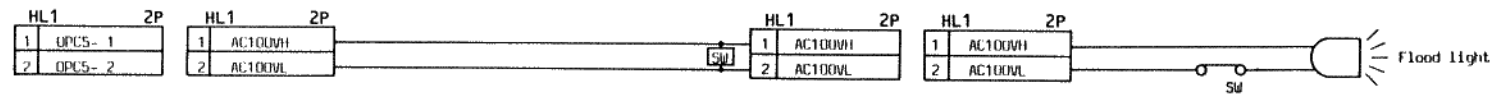

Item or Code No.	Material & Size	qt.	Process	Remark

Scale	---	Designed	By	Drawn	Checked	Traced	Checked	By	By	By	Name	FLOOD LIGHT WIRING
No.											No.	M 1 0 1 0 5 - 9 0 - 0 2 1 -

Commercial Reference	Sym.	Date	Revision	Signed	CS

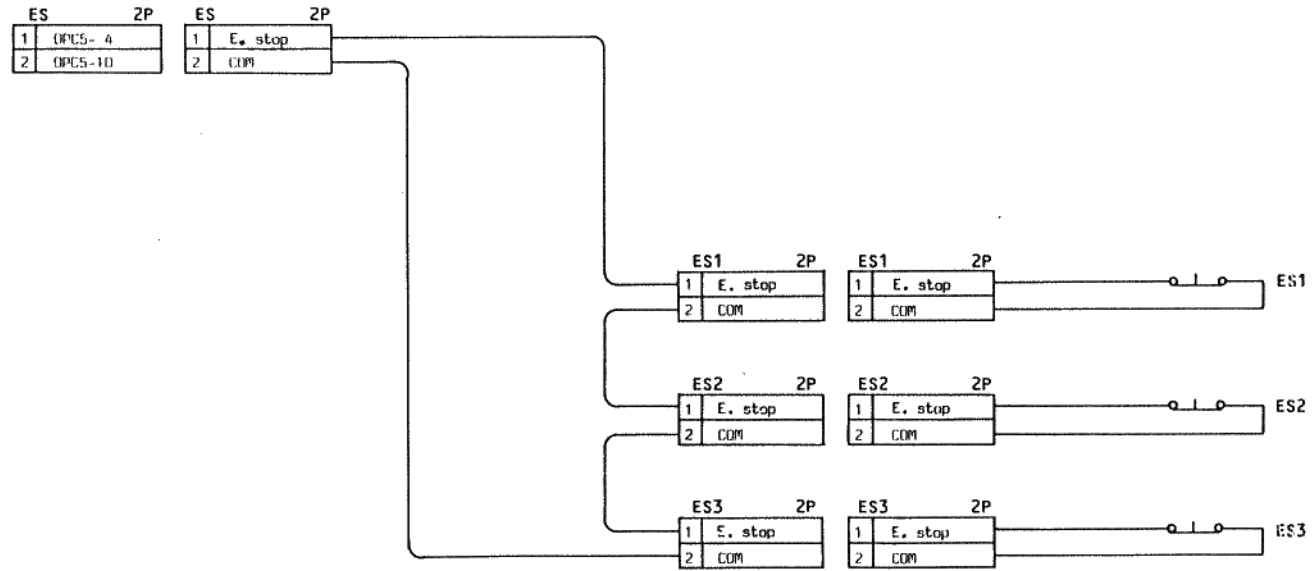

Qty	Item or Code No.	Material & Size	qt.	Process	Remark
				Name E. STOP WIRING	
				No. M 1 0 1 0 5 - 9 0 - 0 2 2 -	

Commercial Entered	Sym.	Date	Revision	Signed	chk

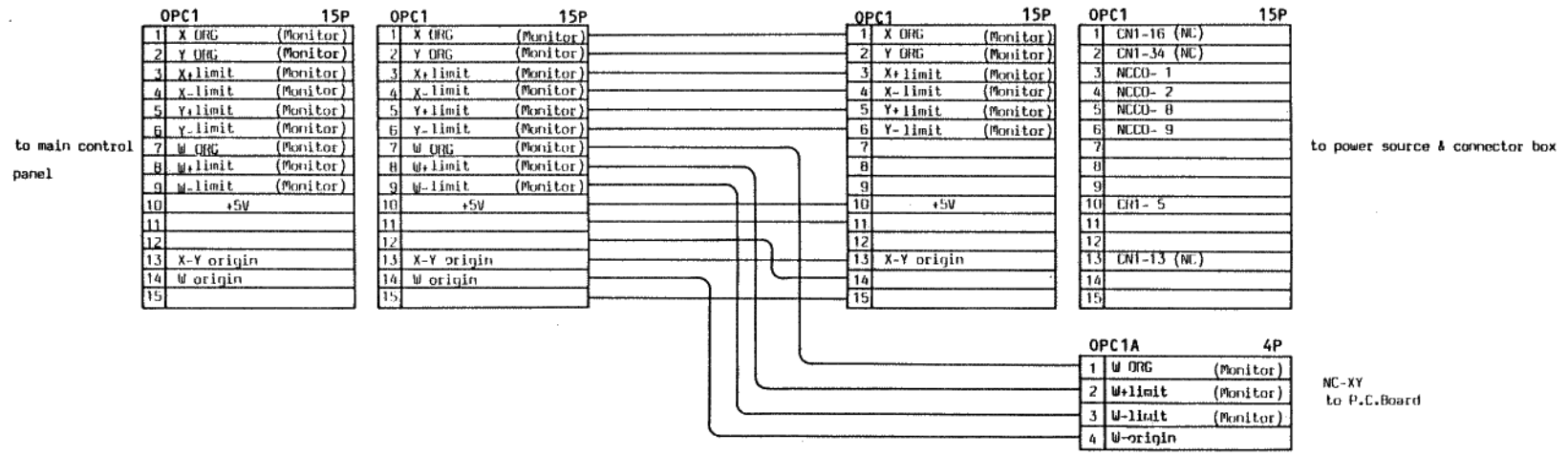

Qty	Item or Code No.	Material & Size	qt.	Process	Remark
					Name
					MAIN CONTROL PANEL WIRING 1
					No.
					M 1 0 1 0 5 - 9 0 - 0 2 3 -

Commercial Tolerance	Sym.	Date	Revision	Signed	CS

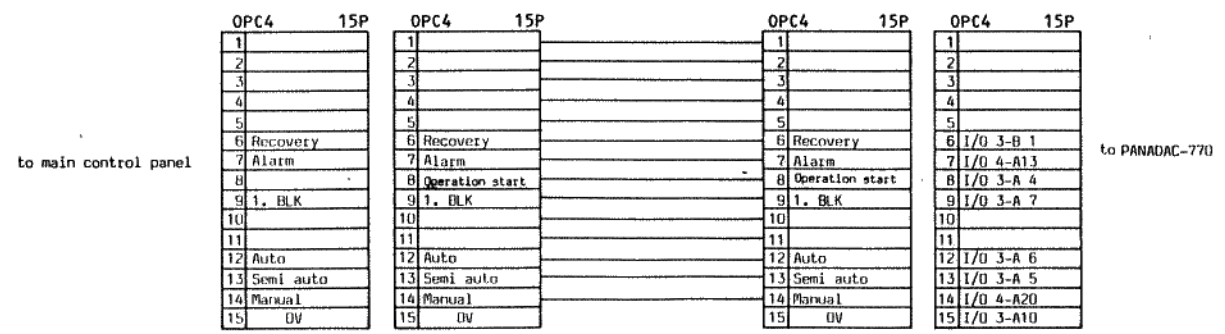
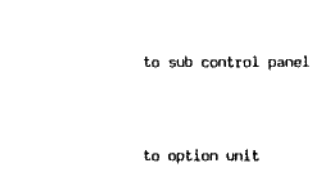
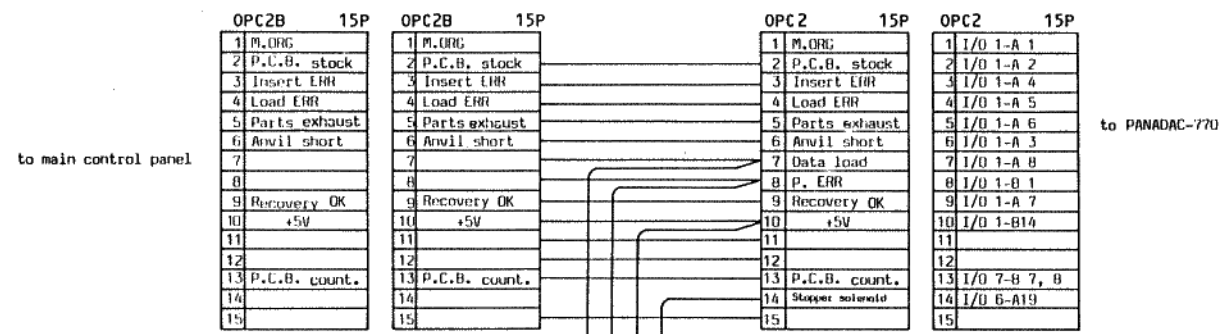

OPERATION AFTER

Item	Item or Code No.	Material & Size	qt.	Process	Remark
					Name
					MAIN CONTROL PANEL WIRING 2
					No.
					M 1 0 1 0 5 - 9 0 - 0 2 4 -

Commercial Reference	Sym.	Date	Revision	Signed	Chk

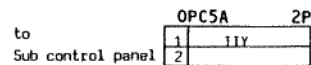
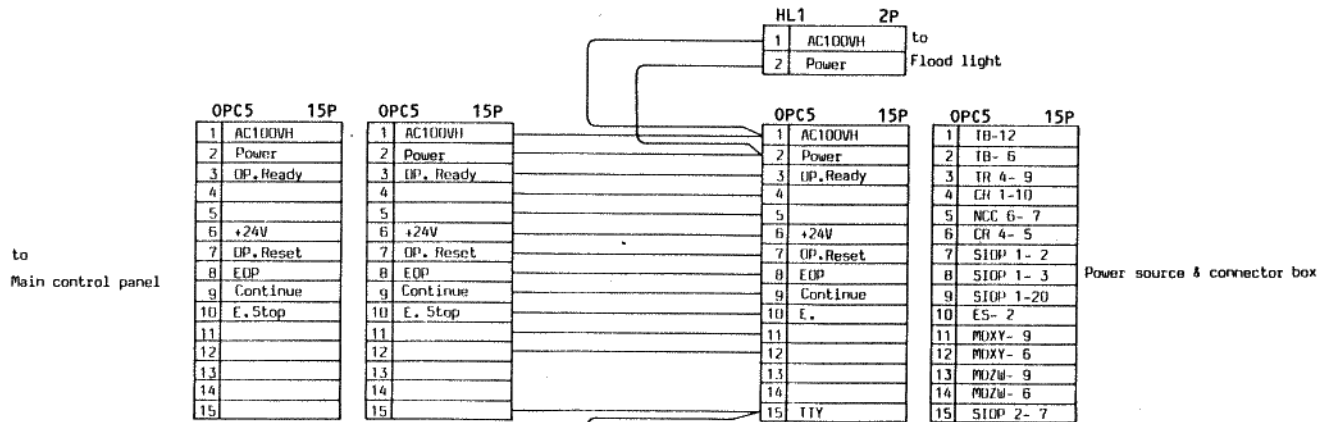
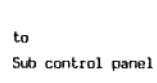
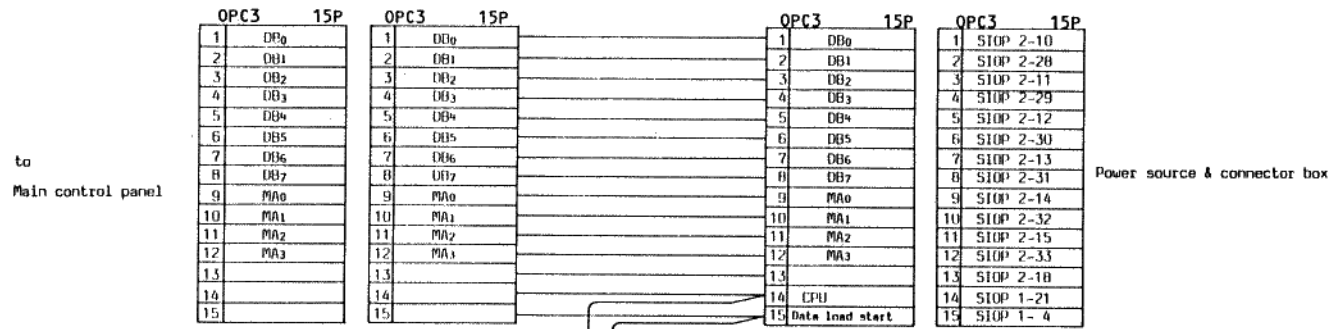

Qty	Item or Code No.	Material & Size	qt.	Process	Remark
Name MAIN CONTROL PANEL WIRING 3					
No. M 1 0 1 0 5 - 9 0 - 0 2 5					

Commercial Reference	Sym.	Date	Revision	Signed

OPC7		15P
1	Monitoring	PN0N
2	Monitoring	PN1N
3	Monitoring	PN2N
4	Monitoring	PN3N
5	Monitoring	PN4N
6	Monitoring	PN5N
7	Monitoring	PN6N
8	Monitoring	PN7N
9		
10		
11		
12	MA ₄	
13	MA ₅	
14	MA ₆	
15	MA ₇	

to main control panel

OPC7		15P
1	Monitoring	PN0N
2	Monitoring	PN1N
3	Monitoring	PN2N
4	Monitoring	PN3N
5	Monitoring	PN4N
6	Monitoring	PN5N
7	Monitoring	PN6N
8	Monitoring	PN7N
9		
10		
11		
12	MA ₄	
13	MA ₅	
14	MA ₆	
15	MA ₇	

OPC7		15P
1	Monitoring	PN0N
2	Monitoring	PN1N
3	Monitoring	PN2N
4	Monitoring	PN3N
5	Monitoring	PN4N
6	Monitoring	PN5N
7	Monitoring	PN6N
8	Monitoring	PN7N
9		
10		
11		
12	MA ₄	
13	MA ₅	
14	MA ₆	
15	MA ₇	

OPC7		15P
1	Monitor-2	-2
2	Monitor-3	-3
3	Monitor-4	-4
4	Monitor-5	-5
5	Monitor-6	-6
6	Monitor-7	-7
7	Monitor-8	-8
8	Monitor-9	-9
9	CR 1-5	
10		
11		
12	SIOP 2-16	
13	SIOP 2-34	
14	SIOP 2-17	
15	SIOP 2-35	

to power source & connector box

OPC8		15P
1	PROG.	
2	Insert	
3	PLC I/O	
4	Reset	
5	Sift	
6	(-)	
7	OV	
8		
9		
10		
11		
12	OV	
13	OV	
14	+5V	
15	+5V	

to main control panel

OPC8		15P
1	PROG.	
2	Insert	
3	PLC I/O	
4	Reset	
5	Sift	
6	(-)	
7	OV	
8		
9		
10		
11		
12	OV	
13	OV	
14	+5V	
15	+5V	

OPC8		15P
1	PROG.	
2	Insert	
3	PLC I/O	
4	Reset	
5	Sift	
6	(-)	
7	OV	
8		
9		
10		
11		
12	OV	
13	OV	
14	+5V	
15	+5V	

OPC8		15P
1	SIOP 1-12	
2	SIOP 1-30	
3	SIOP 1-13	
4	SIOP 1-31	
5	SIOP 1-14	
6	SIOP 1-32	
7	SIOP 1-18	
8	SIOP 1-33	
9	SIOP 1-16	
10	SIOP 1-34	
11	SIOP 1-17	
12	SIOP 1-36	
13	SIOP 2-2	
14	SIOP 2-19	
15	SIOP 2-1	

to power source & connector box

OPC10		15P
1	N, 7	
2	/, 8	
3	G, 9	
4	M, 5	
5	T, 4	
6	X, 1	
7	Y, 2	
8	Z, 3	
9		
10	Data alteration	
11	Data preset	
12	Origin adjust	
13	Block no. search	
14	Write	
15	EOP, 0	

to main control panel

OPC10		15P
1	N, 7	
2	/, 8	
3	G, 9	
4	M, 5	
5	T, 4	
6	X, 1	
7	Y, 2	
8	Z, 3	
9		
10	Data alteration	
11	Data preset	
12	Origin adjust	
13	Block no. search	
14	Write	
15	EOP, 0	

OPC10		15P
1	N, 7	
2	/, 8	
3	G, 9	
4	M, 5	
5	T, 4	
6	X, 1	
7	Y, 2	
8	Z, 3	
9		
10	Data alteration	
11	Data preset	
12	Origin adjust	
13	Block no. search	
14	Write	
15	EOP, 0	

OPC10		15P
1	SIOP 1- 8	
2	SIOP 1-26	
3	SIOP 1- 9	
4	SIOP 1-27	
5	SIOP 1-10	
6	SIOP 1-28	
7	SIOP 1-11	
8	SIOP 1-29	
9		
10	SIOP 1- 6	
11	SIOP 1-23	
12	SIOP 1- 5	
13	SIOP 1-22	
14	SIOP 1-24	
15	SIOP 2-24	

to power source & connector box

Qty	Item or Code No.	Material & Size	qt.	Process	Remark

Scale	Checked	Drawn	Traced	Checked	Checked	Checked	Checked
Name: MAIN CONTROL PANEL WIRING 4							
No: M 1 0 1 0 5 - 9 0 - 0 2 6 -							

Commercial Tolerance	Sym.	Date	Revision	Signed	Chk

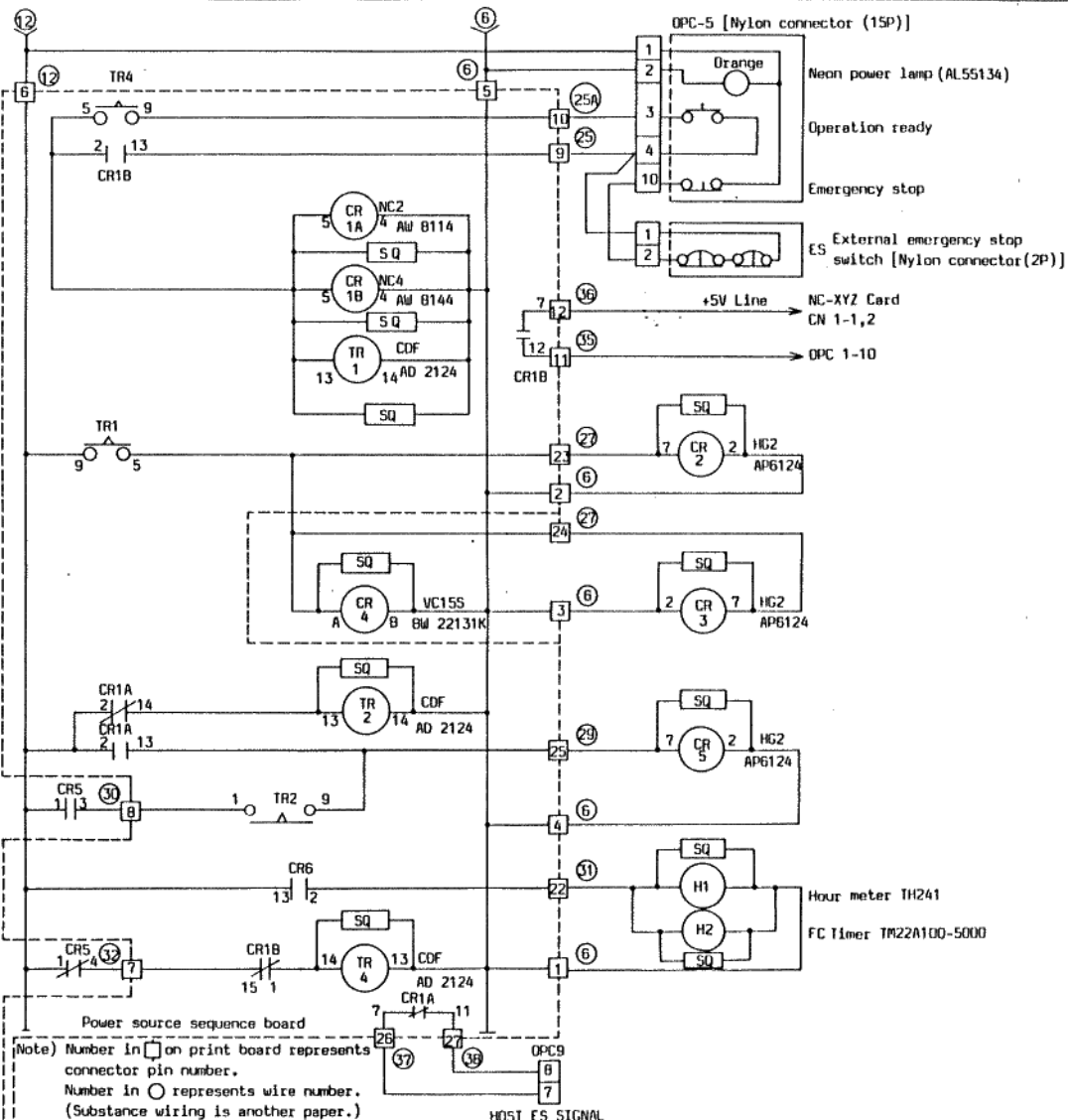
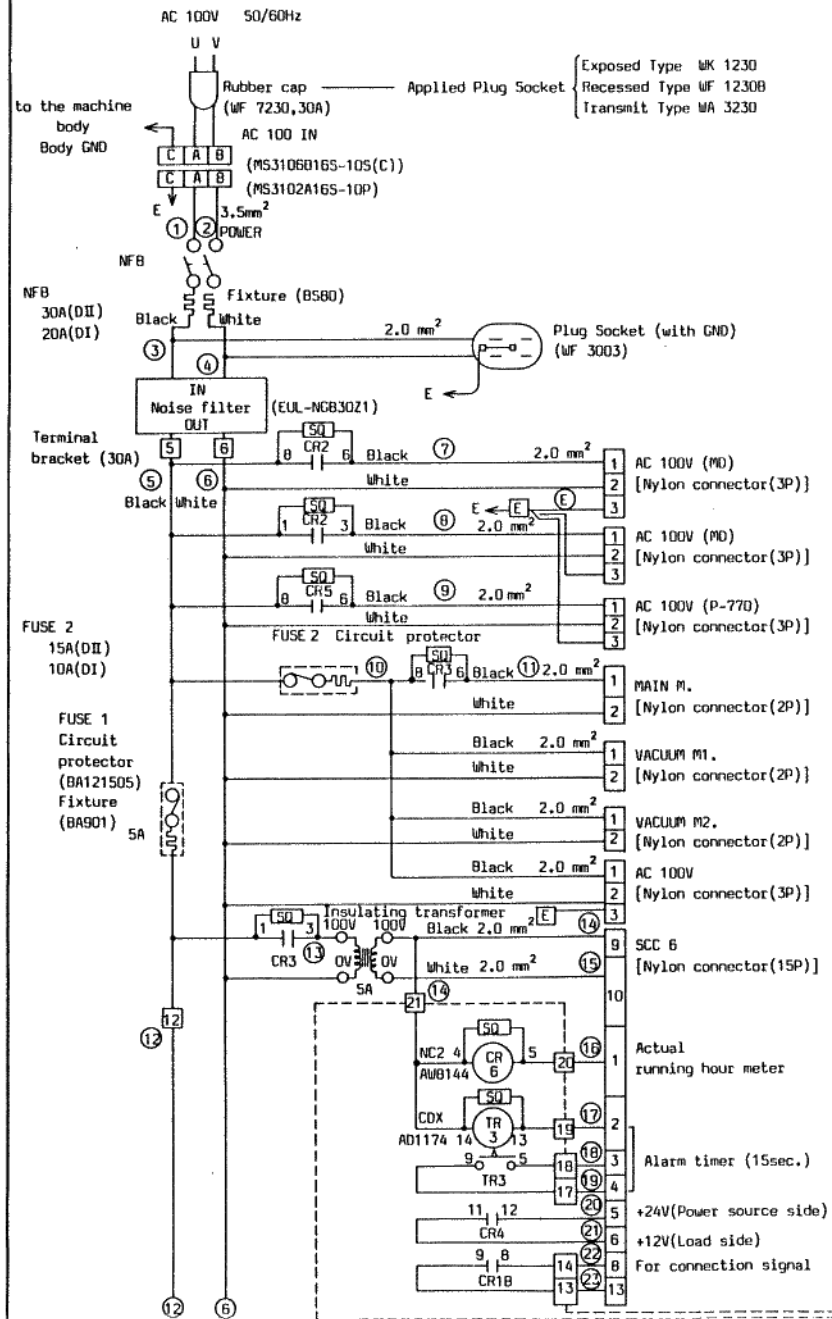

Note) Number in □ on print board represents connector pin number.
 Number in ○ represents wire number.
 (Substance wiring is another paper.)
 SQ is S-1205 (OKAYA).

Qty	Item or Code No.	Material & Size	qt.	Process	Remark
Name POWER SOURCE & CONNECTOR BOX WIRING DIAGRAM					
No. M 1 0 1 0 5 - 9 0 - 2 0 0					

MAIN CONTROL PANEL

OPC1 15P		OPC3 15P		OPC5 15P	
1	CN 1-16 (NC)	1	SIOP 2-10	1	TB-12
2	CN 1-34 (NC)	2	SIOP 2-28	2	TB- 6
3	NCC 0- 1	3	SIOP 2-11	3	TR 4- 9
4	NCC 0- 2	4	SIOP 2-29	4	CR 1B- 3
5	NCC 0- 8	5	SIOP 2-12	5	SCC 6-7
6	NCC 0- 9	6	SIOP 2-30	6	CR 4-12
7	CN 1-17 (NC)	7	SIOP 2-13	7	SIOP 1- 2
8	NCC 1- 6	8	SIOP 2-31	8	SIOP 1- 3
9	NCC 1- 1	9	SIOP 2-14	9	SIOP 1-20
10	CR 1B-12	10	SIOP 2-32	10	ES- 2
11		11	SIOP 2-15	11	MOXY- 9
12		12	SIOP 2-33	12	MOXY- 6
13	CN 1-13 (NC)	13		13	MDZ- 9
14	OPC 9- 9	14	SIOP 1-21	14	MDZ- 6
15	OPC 6-10	15	SIOP 1- 4	15	SIOP 2- 7

SUB CONTROL PANEL

OPC6 15P		OPC7 15P	
1	CN 1-23 (NC)	1	Monitor 1- 2
2	CN 1-26 (NC)	2	Monitor 1- 3
3	CN 1-29 (NC)	3	Monitor 1- 4
4		4	Monitor 1- 5
5	CN 1-33 (NC)	5	Monitor 1- 6
6	CN 1-15	6	Monitor 1- 7
7	CN 1-31	7	Monitor 1- 8
8	CN 1-14	8	Monitor 1- 9
9	CN 1-32	9	CR 1B-12
10	OPC 1-15	10	
11	Monitor-1B	11	
12	For future use	12	SIOP 2-16
13	For future use	13	SIOP 2-34
14	For future use	14	SIOP 2-17
15	For future use	15	SIOP 2-35

X.Y.Z AXIS WIRING

NCC0 15P		NCC1 15P	
1	CN 1-22 (NC)	1	CN 1-10 (NC)
2	CN 1- 4 (NC)	2	CN 1-12 (NC)
3	CN 1- 6 (NC)	3	CN 1-21 (NC)
4	CN 1-24 (NC)	4	CN 1-30 (NC)
5	CN 1-19 (NC)	5	CN 1- 3 (NC)
6	CN 1- 1 (NC)	6	CN 1-2B (NC)
7		7	
8	CN 1-25 (NC)	8	
9	CN 1- 7 (NC)	9	
10	CN 1- 9 (NC)	10	
11	CN 1-27 (NC)	11	
12	CN 1-20 (NC)	12	TB-12
13	CN 1- 2 (NC)	13	TB-12
14		14	TB- 5
15		15	TB- 5

ROTARY ENCODER

NCC2 15P	
1	CN 2-26 (NC)
2	CN 2-25 (NC)
3	CN 2- 2 (NC)
4	CN 2-19 (NC)
5	CN 2- 1 (NC)
6	CN 2-20 (NC)
7	CN 2- 4 (NC)
8	CN 2-21 (NC)
9	CN 2- 3 (NC)
10	CN 2-22 (NC)
11	CN 2- 6 (NC)
12	CN 2-23 (NC)
13	CN 2- 5 (NC)
14	CN 2-24 (NC)
15	

AC100V(MD) 3P

1	CR - 5
2	TB- 5
3	TB- E

AC100V(MD) 3P

1	CR 2- 3
2	TB- 5
3	TB- E

AC100V(P-770) 3P

1	CR 5- 6
2	TB- 6
3	TB- E

AC100V IN 3P

1	TB- 1
2	TB- 2
3	TB- E

VACUUM M 2P

1	CR 3- 5
2	TB- 5

MAIN M 2P

1	CR 3- 6
2	TB- 6

MOTOR DRIVER

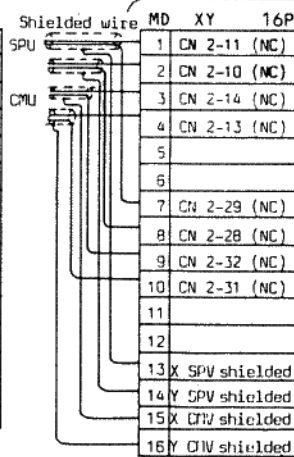

MD XY 16P		MD ZW 10P		COUNTER 10P	
1	SIOP 1- 8	1	CN 2-11 (NC)	1	NCC 2- 3
2	SIOP 1-26	2	CN 2-10 (NC)	2	NCC 2- 4
3	SIOP 1- 9	3	CN 2-14 (NC)	3	NCC 2- 6
4	SIOP 1-27	4	CN 2-13 (NC)	4	NCC 2- 7
5	SIOP 1-10	5		5	NCC 2- 8
6	SIOP 1-28	6		6	NCC 2-10
7	SIOP 1-11	7	CN 2-29 (NC)	7	NCC 2-11
8	SIOP 1-29	8	CN 2-28 (NC)	8	NCC 2-12
9		9	CN 2-32 (NC)	9	NCC 2-14
10	SIOP 1- 6	10	CN 2-31 (NC)	10	
11	SIOP 1-23	11			
12	SIOP 1- 5	12			
13	SIOP 1-22	13	X SPV shielded		
14	SIOP 1-24	14	Y SPV shielded		
15	SIOP 2-24	15	X CIV shielded		
		16	Y CIV shielded		

G CPU 36P		PTR/PTP 36P		OPC8 15P		OPC9 15P	
1	CN 2-PTR- 1	1	CN 2-PTR-36	1	SIOP 1-12	1	SIOP 2-21
2	CN 2-PTR- 2	2	CN 2-PTR-12	2	SIOP 1-30	2	SIOP 2- 4
3	CN 2-PTR- 3	3	CN 2-PTR-30	3	SIOP 1-13	3	SIOP 2-22
4	CN 2-PTR- 4	4	CN 2-PTR-13	4	SIOP 1-31	4	SIOP 2- 5
5	CN 2-PTR- 5	5	CN 2-PTR-16	5	SIOP 1-14	5	SIOP 2-23
6	CN 2-PTR- 6	6	CN 2-PTR-24	6	SIOP 1-32	6	SIOP 2- 6
7	CN 2-PTR- 7	7	CN 2-PTR-25	7	SIOP 1-15	7	SIOP 2-36/CR1A-7
8	CN 2-PTR- 8	8	CN 2-PTR-26	8	SIOP 1-33	8	SIOP1-25/CR1A-11
9	CN 2-PTR- 9	9	CN 2-PTR-27	9	SIOP 1-16	9	SIOP1-7/OPC1-14
10	CN 2-PTR-10	10	CN 2-PTR-33	10	SIOP 1-34	10	
11	CN 2-PTR-11	11		11	SIOP 1-17	11	
12		12	CN 2-PTR-34	12	SIOP 1-36	12	
13		13		13	SIOP 2-18	13	
14		14		14	SIOP 2-19	14	
15		15		15	SIOP 2- 1	15	
16		16					
17	RS-232C	17					
18	CN 2-PTR-16	18	Monitor-19				
19	CN 2-PTR-19	19	Monitor-32				
20	CN 2-PTR-20	20	Monitor-34				
21	CN 2-PTR-21	21					
22	CN 2-PTR-22	22					
23	CN 2-PTR-23	23					
24	CN 2-PTR-24	24					
25	CN 2-PTR-25	25					
26	CN 2-PTR-26	26					
27	CN 2-PTR-27	27	Monitor-21				
28	CN 2-PTR-28	28	Monitor-22				
29	CN 2-PTR-29	29	Monitor-23				
30		30	Monitor-24				
31		31	Monitor-25				
32		32	Monitor-26				
33		33	Monitor-27				
34		34	Monitor-28				
35		35	Monitor-29				
36	CN 2-PTR-36	36	Monitor-36				

TTY CARD		TTY (10P) CONNECTOR	
1	OPC 2-12	1	TTY Card 1
2	OPC 2- 5	7	TTY Card 8
3	OPC 2- 3	8	TTY Card 5
4	OPC 2-10	9	TTY (Connector)- 9
5	OPC 2- 4	10	TTY (Connector)-10

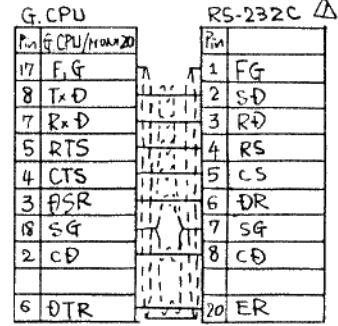

Item or Code No.	Material & Size	qt.	Process	Remark
Name: POWER SOURCE & CONNECTOR BOX CONNECTOR WIRING				
No. M 1 0 1 0 5 - 9 0 - 2 0 1				

Commercial Reference	Sym.	Date	Revision	Signed	ck

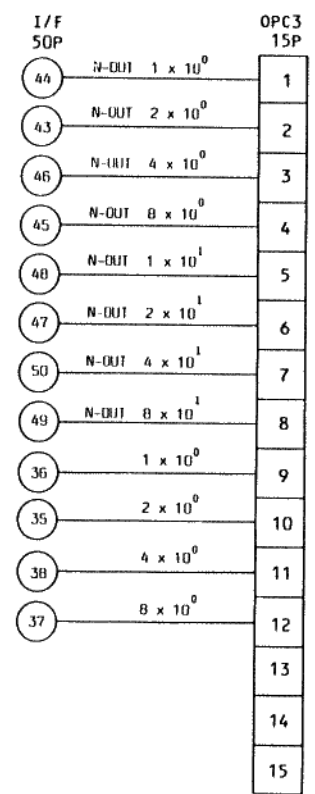
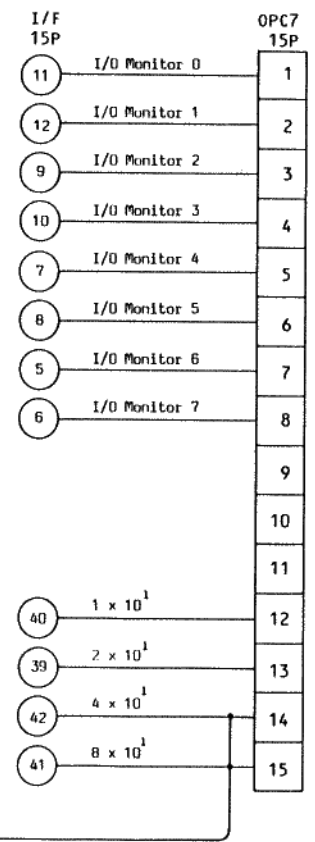
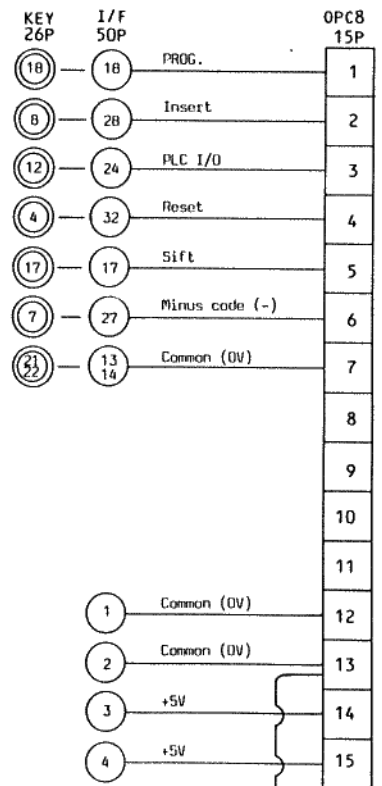
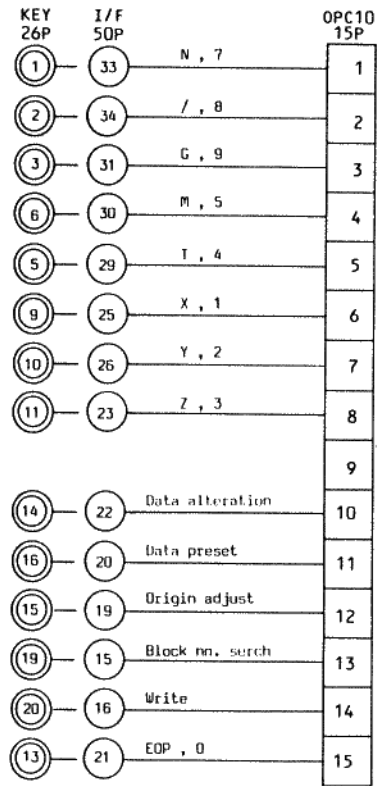

Item or Code No.	Material & Size	qt.	Process	Remark
Name: MAIN CONTROL PANEL WIRING 2				
No. M 1 0 1 0 5 - 9 0 - 2 5 1 -				

Commercial Telephone	Sym.	Date	Revision	Signed	CS

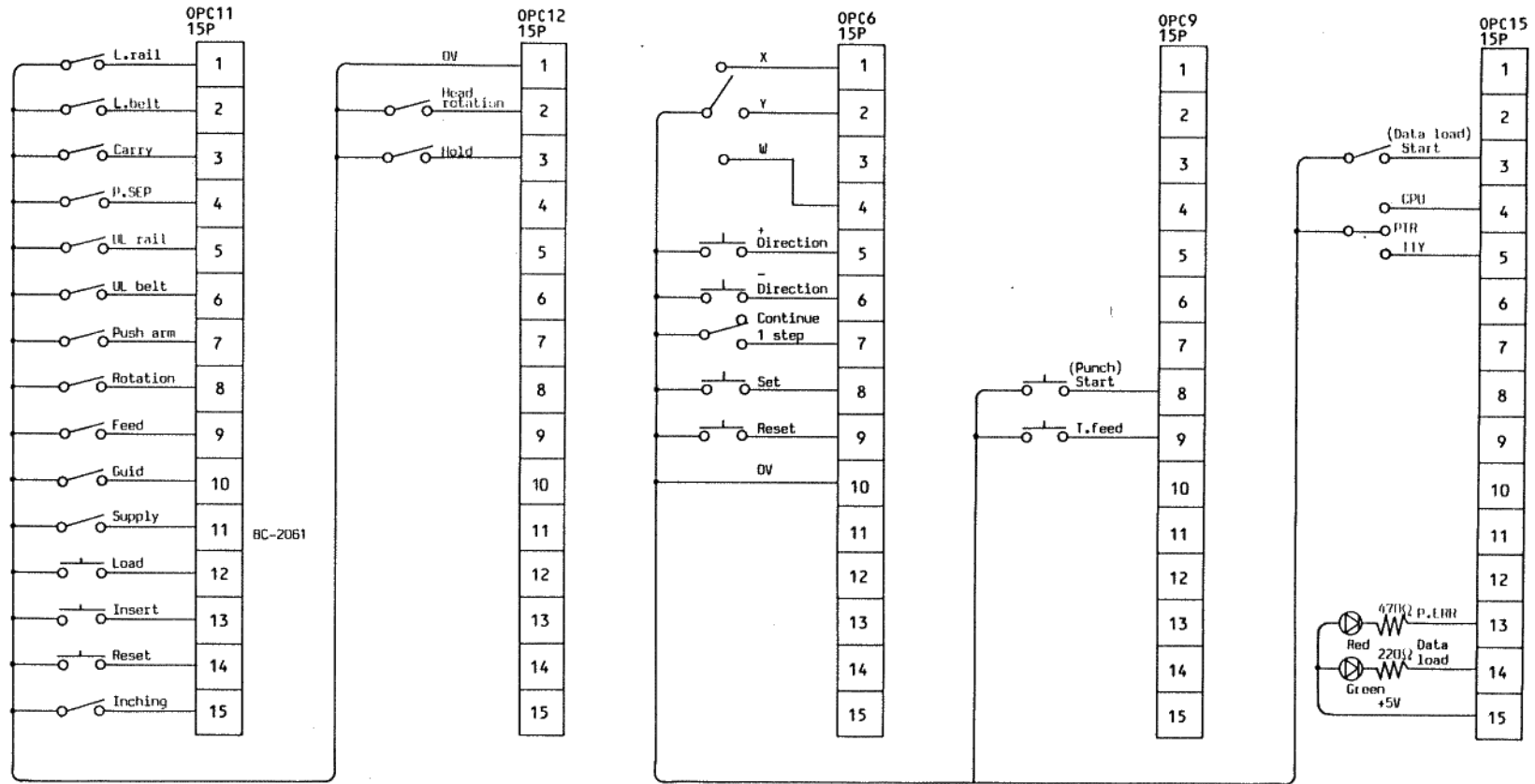

Qty	Item or Code No.	Material & Size	qt.	Process	Remark

Scale	Designed	Checked	Drawn	Traced	Assembled	Name	SUB CONTROL BOX WIRING
						No.	
							M 1 0 1 0 5 - 9 0 - 2 5 2 -

Control Reference	Sym.	Date	Revision	Signed

NC-XYZ 10

CN2		36P	CN1		36P
	Signal	Connect to		Signal	Connect to
1	X-Z phase (Encoder)	NCC 2- 5	1	+5V	NCC 0- 6
2	X-A phase (Encoder)	NCC 2- 3	2	+5V	NCC 0-13
3	Y-Z phase (Encoder)	NCC 2- 9	3	+5V	NCC 1- 5
4	Y-A phase (Encoder)	NCC 2- 7	4	X - limit	NCC 0- 2
5	Z-Z phase (Encoder)	NCC 2-13	5	X interlock	SCC 6-15
6	Z-A phase (Encoder)	NCC 2-11	6	X origin slow	NCC 0- 3
7			7	Y - limit	NCC 0- 9
8			8	Y interlock	SCC 6-15
9	ZSPV Detection	PROZ - 1	9	Y origin slow	NCC 0-10
10	YSPV Detection	PROY - 2	10	Z - limit	NCC 1- 1
11	XSPV Detection	PROX - 1	11	Z interlock	SCC 6-14
12	ZCPV Command voltage	PROZ - 3	12	Z origin slow	NCC 1- 2
13	YCPV Command voltage	PROY - 4	13	Manual origin return	OPC 1-13
14	XCPV Command voltage	PROX - 3	14	Teaching set	OPC 6- 8
15			15	Manual mirror	OPC 6- 6
16	-15V		16	X origin monitor	OPC 1- 1
17	OV		17	Z origin monitor	OPC 1- 7
18	+15V		18		
19	X-B phase (Encoder)	NCC 2- 4	19	OV	NCC 0- 5
20	XPG (GND)	NCC 2- 6	20	OV	NCC 0-12
21	Y-B phase (Encoder)	NCC 2- 8	21	OV	NCC 1- 3
22	YPG (GND)	NCC 2-10	22	X + limit	NCC 0- 1
23	Z-B phase (Encoder)	NCC 2-12	23	X manual	OPC 6- 1
24	ZPG (GND)	NCC 2-14	24	X table origin	NCC 0- 4
25	OV	NCC 2- 2/PROZ - 0	25	Y + limit	NCC 0- 8
26	+5V	NCC 2- 1/PROY - 10	26	Y manual	OPC 6- 2
27	ZSPG (GND)	PROZ - 7	27	Y table origin	NCC 0-11
28	YSPG (GND)	PROY - 8	28	Z + limit	NCC 1- 6
29	XSPG (GND)	PROX - 7	29	Z manual	OPC 6- 3
30	ZCPVG (GND)	PROZ - 9	30	Z table origin	NCC 1- 4
31	YCPVG (GND)	PROY - 10	31	Manual 1 stop	OPC 6- 7
32	XCPVG (GND)	PROX - 9	32	Teaching reset	OPC 6- 9
33			33	Manual plus	OPC 6- 5
34	-15V		34	Y origin monitor	OPC 1- 2
35	0		35	OV	
36	+15V		36	OV	

S10P 10

CN1-MIN		50P	CN2-OUT		50P
	Signal	Connect to		Signal	Connect to
1	+5V		1	+5V	OPC 0-15
2	Operation reset	OPC 5- 7	2	(1x10 ³)	
3	OP	OPC 5- 8	3	(4x10 ³)	
4	Data load start	OPC 3-15	4	(1x10 ⁶)	OPC 9- 2
5	Origin adjust	OPC10-12	5	(1x10 ⁸)	OPC 9- 6
6	Data alteration	OPC10-10	6	Direction (mirror)	OPC 9- 6
7	Feed/ON line	OPC 9- 9	7	FLY	OPC 5-15
8	N,7	OPC10- 1	8		
9	G,9	OPC10- 3	9		
10	I,4	OPC10- 5	10	000	OPC 3- 1
11	Y,2	OPC10- 7	11	002	OPC 3- 3
12	OPRG (1x10 ⁰)	OPC 9- 1	12	006	OPC 3- 5
13	PLD 1/0 (4x10 ⁰)	OPC 8- 3	13	006 for display	OPC 3- 7
14	5ift	OPC 8- 5	14	000 indication	OPC 3- 9
15	(4x10 ¹)		15	002	OPC 3-11
16	(1x10 ²)	OPC 8- 9	16	004	OPC 7-12
17	(4x10 ²)	OPC 8-11	17	006	OPC 7-16
18	OV	OPC 8- 7	18	OV	OPC 8-13
19	+5V		19	+5V	OPC 8-14
20	Continue	OPC 5- 9	20	(2x10 ⁴)	
21	OPH	OPC 3-14	21	(8x10 ⁴)	OPC 9- 1
22	Block NO. serch	OPC10-13	22	(2x10 ⁶)	OPC 9- 3
23	Data preset	OPC10-11	23	(8x10 ⁶)	OPC 9- 5
24	Data set	OPC10-14	24	EEP	OPC10-15
25	Punch start/E. stop	OPC 9- 8	25	ADD	
26	I,8	OPC10- 2	26	ACC	
27	M,5	OPC10- 4	27		
28	X,1	OPC10- 6	28	001	OPC 3- 2
29	Z,3	OPC10- 8	29	003	OPC 3- 4
30	Insert (2x10 ⁰)	OPC 8- 2	30	005	OPC 3- 6
31	Reset (8x10 ⁰)	OPC 8- 4	31	007 for display	OPC 3- 8
32	(-) (2x10 ¹)	OPC 8- 6	32	001 indication	OPC 3-10
33	(8x10 ¹)	OPC 8- 8	33	003	OPC 3-12
34	(2x10 ²)	OPC 8-10	34	005	OPC 7-13
35	(8x10 ²)		35	007	OPC 7-15
36	OV	OPC 8-12	36	OV	OPC 9- 7

Qty	Item or Code No.	Material & Size	Process	Remark

Scale	Designed	Checked	Drawn	Traced	Checked	Name	PANADAC-770 CONNECTOR WIRING I
						No.	M 1 0 1 0 5 - 9 0 - 3 0 0

Commercial Reference	Sym.	Date	Revision	Signed	Checked

NC-YW

MONI 20

OBC 10

50P

Signal	Connect to
1 5V	NCC 3-5
2 V axis table origin	NCC 3-4
3 V axis origin slow	NCC 3-2
4 V axis teaching reset	OPC 6-9
5 V axis manual 1 step	OPC 6-7
6 V axis manual origin return	OPC 1-7
7 V axis interlock	
8 V axis - limit	NCC 3-1
9 V axis - limit monitor	OPC 1-9
10 W axis table origin	NCC 3-12
11 W axis origin slow	NCC 3-10
12 W axis teaching reset	OPC 6-9
13 W axis manual 1 step	OPC 6-7
14 W axis manual origin return	OPC 1-7
15 W axis interlock	
16 W axis - limit	NCC 3-9
17 W axis - limit monitor	OPC 1-9
18 Stop	
19 0V	NCC 3-3
20 V axis A phase	
21 V axis B phase	
22 V axis PPN	MDZW -3
23 V axis direction (+)	MDZW -2
24 0V	NCC 3-11
25 0V	
26 +5V	NCC 3-13
27 V axis phase origin	NCC 3-7
28 V axis manual	OPC 6-4
29 V axis teaching set	OPC 6-8
30 V axis manual +	OPC 6-5
31 V axis manual -	OPC 6-6
32 V axis + limit	NCC 3-6
33 V axis + limit monitor	OPC 1-8
34 V axis phase origin monitor	
35 W axis phase origin	NCC 3-15
36 W axis manual	OPC 6-4
37 W axis teaching set	OPC 6-8
38 W axis manual +	OPC 6-5
39 W axis manual -	OPC 6-6
40 W axis + limit	NCC 3-14
41 W axis + limit monitor	OPC 1-8
42 W axis origin monitor	OPC 1-7
43 0V	MDZW -1
44 0V	
45 W axis A phase	
46 W axis B phase	
47 W axis PPN	MDZW -5
48 W axis direction (+)	MDZW -4
49 0V	
50 0V	

CN1-MON

36P

Signal	Connect to
1 +5V	
2 Monitoring data	PN10N OPC 7-1
3 Monitoring data	PN11N OPC 7-2
4 Monitoring data	PN2N OPC 7-3
5 Monitoring data	PN3N OPC 7-4
6 Monitoring data	PN4N OPC 7-5
7 Monitoring data	PN5N OPC 7-6
8 Monitoring data	PN6N OPC 7-7
9 Monitoring data	PN7N OPC 7-8
10	
11 Monitoring digi-SW	DGS00
12 Monitoring digi-SW	DGS01
13 Monitoring digi-SW	DGS02
14 Monitoring digi-SW	DGS10
15 Monitoring digi-SW	DGS11
16 Monitoring digi-SW	DGS12
17	
18 0V	OPC 6-11
19 +5V	PTR/PTP -18
20	
21 Punch data	PD0 PTR/PTP -27
22 Punch data	PD1 PTR/PTP -28
23 Punch data	PD2 PTR/PTP -29
24 Punch data	PD3 PTR/PTP -30
25 Punch data	PD4 PTR/PTP -31
26 Punch data	PD5 PTR/PTP -32
27 Punch data	PD6 PTR/PTP -33
28 Punch data	PD7 PTR/PTP -34
29 Punch strobe	KOT7N
30	
31	
32 -5V	PTR/PTP -20
33	
34 +12V	PTR/PTP -21
35	
36 0V	PTR/PTP -36

CN2-PTR

36P

Signal	Connect to
1 +5V	G.CPU -1
2 Carrier detection	CD1 G.CPU -2
3 Companion side terminal ready	DR1 G.CPU -3
4 For transmit	CS1 G.CPU -4
5 Transmit request	RS1 G.CPU -5
6 Terminal ready	ER1 G.CPU -6
7 Received data	RD1 G.CPU -7
8 Transmit data	SD1 G.CPU -8
9	G.CPU -9
10	G.CPU -10
11	G.CPU -11
12 PTR data	CH0 PTR/PTP -2
13 PTR data	CH2 PTR/PTP -4
14 PTR data	CH4 PTR/PTP -7
15 PTR data	CH6 PTR/PTP -9
16 PTR data	CH8 PTR/PTP -5
17 Protect ground	FG
18 Signal ground	GS1 G.CPU -18
19 +5V	G.CPU -19
20 Carrier detection	CD2 G.CPU -20
21 Companion side terminal ready	DR2 G.CPU -21
22 For transmit	CS2 G.CPU -22
23 Transmit request	RS2 G.CPU -23
24 Terminal ready	ER2 G.CPU -24
25 Received data	RD2 G.CPU -25
26 Transmit data	SD2 G.CPU -26
27	G.CPU -27
28	G.CPU -28
29	
30 PTR data	CH1 PTR/PTP -3
31 PTR data	CH3 PTR/PTP -6
32 PTR data	CH5 PTR/PTP -8
33 PTR data	CH7 PTR/PTP -10
34 PTR data	PDWN PTR/PTP -12
35	
36 Signal ground	SG2 G.CPU -36 PTR/PTP -1

14P

Signal	Connect to
1 +12V	I1Y card -6
2 +5V	I1Y card -7
3 0V	I1Y card -3
4 0V	I1Y card -5
5 0V	I1Y card -2
6	
7	
8	
9 TWS(L)	to REBOΩ
10 TWS(H)	I1Y card -4
11 T. Coil	I1Y card -8
12 T. Out	I1Y card -1
13	
14	

Not belong to power source & connector box.

Qty.	Item or Code No.	Material & Size	qt.	Process	Remark
Name: PANADAC-770 CONNECTOR WIRING II					
No. M 1 0 1 0 5 - 9 0 - 3 0 1					

General Reference	Sym.	Date	Revision	Signed	chk

	I/O	P.C. BOARD NAME	STROBE WIRING		APPLICATION	
			STROBE	ADDRESS	STANDARD EQUIPMENT	OPTION
①	I/O 1	PANADAC-730-232 DC-M-OUT	A	130	<input type="checkbox"/>	
			B	140	<input type="checkbox"/>	<input type="checkbox"/>
			C			
			D			
②	I/O 2	PANADAC-730-				
③	I/O 3	PANADAC-730-231 DC-5V-IN	A	350	<input type="checkbox"/>	
			B	360	<input type="checkbox"/>	
			C			
			D			
			E	230		<input type="checkbox"/>
④	I/O 4	PANADAC-730-231 DC-5V-IN	A	000	<input type="checkbox"/>	
			B	010	<input type="checkbox"/>	
			C	020	<input type="checkbox"/>	
			D	030	<input type="checkbox"/>	
			E	260		<input type="checkbox"/>
⑤	I/O 5	PANADAC-730-231 DC-5V-IN	A	040	<input type="checkbox"/>	<input type="checkbox"/>
			B	050	<input type="checkbox"/>	
			C	060	<input type="checkbox"/>	<input type="checkbox"/>
			D	160	<input type="checkbox"/>	<input type="checkbox"/>
			E	250	<input type="checkbox"/>	<input type="checkbox"/>
⑥	I/O 6	PANADAC-730-231 DC-5V-IN	A	330	<input type="checkbox"/>	<input type="checkbox"/>
			B	340	<input type="checkbox"/>	<input type="checkbox"/>
			C	370	<input type="checkbox"/>	<input type="checkbox"/>
			D	150	<input type="checkbox"/>	<input type="checkbox"/>
			E	270	<input type="checkbox"/>	<input type="checkbox"/>
⑦	I/O 7	PANADAC-730-205 DC-OUT		120	<input type="checkbox"/>	<input type="checkbox"/>
⑧	I/O 8	PANADAC-730-204 AC-OUT		320		<input type="checkbox"/>
⑨	I/O 9	PANADAC-730-204 AC-OUT		100	<input type="checkbox"/>	
⑩	I/O 10	PANADAC-730-204 AC-OUT		110	<input type="checkbox"/>	
⑪	I/O 11	PANADAC-730-204 AC-OUT		300		<input type="checkbox"/>
⑫	I/O 12	PANADAC-730-204 AC-OUT		310		<input type="checkbox"/>
⑬						

	P-770	P.C. BOARD NAME	REMARKS
⑭	IFR 10	PANADAC-770-204	TIMER, SC ++ NC
⑮	PLC 10	PANADAC-770-216	CPU
⑯	NC-VW	PANADAC-770-03-VW	STEPPING MOTOR CONTROL
⑰	NC - XYZ 10	PANADAC-770-282	X-Y TABLE
⑱	DBC 10	PANADAC-770-280	OPC, NC DATA PROGRAM STORAGE
⑲	SIOP 10	PANADAC-770-281	PROGRAM STORAGE CONTROL PANEL FUNCTION
⑳	MONI 20	PANADAC-730-283	PIR, PTP, CPU
	MONI 10	PANADAC-770-202	

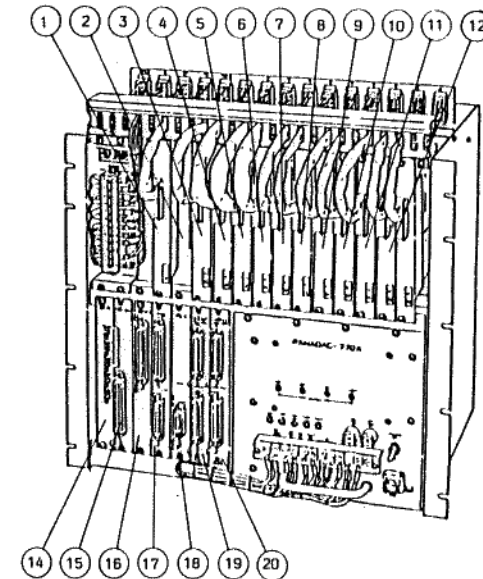

Item or Code No.	Material & Size	qt.	Process	Remark
Name				PANADAC-770 P.C. BOARD SUBSTANCE DIAGRAM
No.				M 1 0 1 0 5 - 9 0 - 3 5 0

PAWADAC-770 S/C UNIT

MAIN CONTROL PANEL

SUB CONTROL PANEL

OPTION (LOADER SIDE)

Signal	Connect to
1 AC100VH	SCC 2- 1
2 AC100VH	SCC 4- 1, SCC 4- 2
3 AC100VH	SCC 7- 2, SCC 9- 2
4 AC100VL	SCC 6-10
5 AC100VL	I/O 2-B10, I/O 9-B10, I/O10-B10
6 +24V Load	SCC 8- 8, SCC 7- 8, SCC 9- 8
7 +24V Load	SCC 1-13, SCC 5- 1
8 +24V Power source	SCC 6- 5
9 0V (+24V)	S/C 6- 7, I/O 7-B10
10 +12V	SCC11- U
11 AC100VL	I/O 8-B10, I/O11-B10, I/O12-B10
12 - 5V	SCC 5- 8

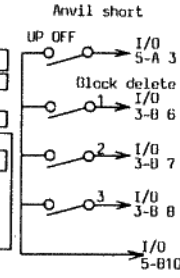

OPC2

1	I/O 1-A 1
2	I/O 1-A 2
3	I/O 1-A 4
4	I/O 1-A 5
5	I/O 1-A 6
6	I/O 1-A 3
7	I/O 1-A 8
8	I/O 1-B 1
9	I/O 1-A 7
10	I/O 1-B14
11	
12	
13	I/O 7-B 7, 8
14	I/O 6-A19
15	

OPC4

1	
2	
3	
4	
5	
6	I/O 3-B 1
7	I/O 4-A13
8	I/O 3-A 4
9	I/O 3-A 7
10	
11	
12	I/O 3-A 6
13	I/O 3-A 5
14	I/O 4-A20
15	I/O 3-A10

OPC11

1	I/O 4-A21
2	I/O 4-B15
3	I/O 4-B17
4	I/O 5-A 2
5	I/O 4-B13
6	I/O 4-B16
7	I/O 5-A 1
8	I/O 4-B21
9	I/O 4-B18
10	I/O 4-B19
11	I/O 4-B20
12	I/O 4-A17
13	I/O 4-A15
14	I/O 4-A19
15	I/O 4-A18

OPC12

1	I/O 4-A22
2	I/O 4-A15
3	I/O 5-A 8
4	
5	
6	
7	
8	
9	
10	
11	
12	
13	
14	
15	

SCC7

1	I/O12-B17,16
2	10- 3
3	SCC 7-2
4	I/O12-B1,2
5	I/O12-B3,4
6	I/O12-B5,6
7	I/O12-B7,8
8	TB- 6
9	I/O 6-A12
10	I/O 6-B 7
11	I/O 8-B 5, 6
12	I/O 9-B 7, 8
13	I/O 9-B17,18
14	I/O 7-B19,20
15	I/O 12-B15,16

SCC8

1	I/O 6-A22
2	I/O 6-B 1
3	I/O 6-B 2
4	I/O 6-B 3
5	I/O 6-B 4
6	I/O 6-B 5
7	I/O 6-A17
8	I/O 6-A19
9	I/O 6-B 8
10	I/O 6-B10
11	I/O 6-B19
12	I/O 6-B20
13	I/O 6-B21
14	I/O 6-B 6
15	I/O12-B19

CYCLE TIMER

INSERTION HEAD

UNLOADER

LOADER

SOLENOID VALVE

INSERTION DETECTION

POWER SOURCE & CONNECTOR BOX

OPTION (UNLOADER SIDE)

SCC0

1	Power source unit TB- 6
2	Power source unit TB- 3
3	I/O 4-A 2
4	I/O 4-A 3
5	I/O 4-A 4
6	I/O 4-A 5
7	I/O 4-A 6
8	I/O 4-A 7
9	I/O 4-A 8
10	I/O 4-A 1
11	I/O 4-B 1
12	I/O 4-B 2
13	I/O 4-B 3
14	I/O 4-B 4
15	I/O 6-B 5

SCC1

1	I/O 4-B 6
2	I/O 4-B 7
3	I/O 4-B 8
4	
5	I/O 5-A22
6	SCC 1- 5
7	I/O 5-B12
8	I/O 5-B20
9	I/O 5-B21
10	I/O 5-A13
11	
12	
13	TB- 7
14	I/O 7-B1,2
15	I/O 7-B3,4

SCC2

1	TB- 1
2	I/O 9-B15,16
3	I/O 5-A 6
4	I/O 5-A 7
5	I/O 5-B 4
6	I/O 5-B 5
7	I/O 5-A20
8	I/O 5-A21
9	I/O 5-A10
10	SCC 2- 9
11	SCC 2-10
12	I/O 1-B 6
13	I/O 5-A19
14	I/O 1-B 8
15	

SCC3

1	SCC 2- 1
2	I/O 9-B 7, 8
3	I/O 5-A 4
4	I/O 5-A 5
5	I/O 5-B 2
6	I/O 5-B 3
7	I/O 5-B13
8	I/O 5-B15
9	I/O 3-B 5
10	I/O 5-B22
11	SCC 1- 7
12	I/O 3-B 4
13	I/O 5-A18
14	I/O 1-B 5
15	I/O 1-B 7

SCC4

1	TB- 2
2	TB- 2
3	I/O 10-B 7, 8
4	
5	I/O 10-B15,16
6	I/O 10-B 1, 2
7	I/O 10-B 3, 4
8	I/O 9-B17,18
9	I/O 9-B 1, 2
10	I/O 9-B 3, 4
11	I/O 9-B 5, 6
12	I/O 10-B17,18
13	I/O 10-B19,20
14	I/O 9-B19,20
15	I/O 10-B5,6

SCC5

1	TB- 7
2	I/O 7-B 5, 6
3	SCC 0- 2
4	SCC 3-10
5	I/O 5-A13
6	I/O 5-A15
7	I/O 5-B 1
8	TB- 12
9	I/O 7-B15,16
10	I/O 7-B17,18
11	SCC 5- 1
12	
13	
14	
15	

SCC6

1	I/O 10-B21,22
2	I/O 9-B21,22
3	SCC 2-9
4	I/O 5-A17
5	TB- 8
6	TB- 6
7	TB- 9
8	I/O1-B 5
9	I/O 9-B 9
10	TB- 4
11	
12	
13	SCC 3-14
14	
15	SCC 0- 6

SCC9

1	I/O11-B17,18
2	TB- 3
3	SCC 9- 2
4	I/O 11-B 1, 2
5	I/O 11-B 3, 4
6	I/O 11-B 5, 6
7	I/O 11-B 7, 8
8	TB- 6
9	SCC 7- 9
10	I/O 6-A 7
11	I/O 8-B 1, 2
12	I/O 8-B 3, 4
13	I/O 8-B15,16
14	I/O 7-B21,22
15	I/O 11-B15,16

SCC10

1	I/O 6-A10
2	I/O 6-A 1
3	I/O 6-A 2
4	I/O 6-A 3
5	I/O 6-A 4
6	I/O 6-A 5
7	I/O 6-A13
8	I/O 6-A15
9	I/O 6-A16
10	I/O 6-B13
11	I/O 6-B15
12	I/O 6-B16
13	I/O 6-B17
14	I/O 6-A 5
15	I/O 6-A 8

SCC11

1	OPC 2-10
2	SCC11- 1
3	I/O 3-B10
4	I/O 5-B16
5	I/O 5-B17
6	I/O 5-B10
7	I/O 5-B19
8	TB-10
9	I/O 5-B 6
10	I/O 5-B 7
11	SCC11- 3
12	SCC11-11
13	I/O 5-B 8
14	
15	

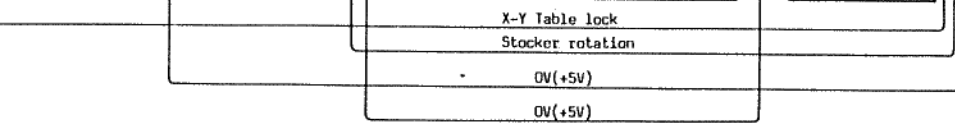

P-770 Power source & connector box unit Terminal Bracket (T.B.)

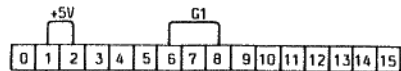

SCC 0- 2
SCC 0- 1
* Dispose of round T.B.

Item or Code No.	Material & Size	qt.	Process	Remark
PANADAC-770 S/C UNIT CONNECTOR WIRING				
Name				
No. M 1 0 1 0 5 - 9 0 - 3 5 1				

Component Reference	Sym.	Date	Revision	Signed	Chk

PC board No.	PC board name	Pin connection	Connected to	Signal	Input address	I/O address	Remarks
I/O 4	PANADAC 730-231 DC-5V-IN ST= A	A 1	SCC 0-3	NO. operation	0 0 0 0	0	
		A 2	SCC 0-3	W. origin (Cycle timer)	0 0 0 1	1	
		A 3	SCC 0-4	Insertion position (Cycle timer)	0 0 0 2	2	
		A 4	SCC 0-5	Insertion detection (Cycle timer)	0 0 0 3	3	
		A 5	SCC 0-6	X-Y table lock (Cycle timer)	0 0 0 4	4	
		A 6	SCC 0-7	Pitch change (Cycle timer)	0 0 0 5	5	
		A 7	SCC 0-8		0 0 0 6	6	
		A 8	SCC 0-9		0 0 0 7	7	
		A 10			OV		
		I/O 4	PANADAC 730-231 DC-5V-IN ST= B	B 1	SCC 0-11		0 0 1 0
B 2	SCC 0-12			Step start (Cycle timer)	0 0 1 1	1	
B 3	SCC 0-13			Feed (Cycle timer)	0 0 1 2	2	
B 4	SCC 0-14			L. block stop	0 0 1 3	3	
B 5	SCC 0-15			Parts exhaust stop input	0 0 1 4	4	
B 6	SCC 1-1			Supply Traverse limit	0 0 1 5	5	
B 7	SCC 1-2			Supply Return limit	0 0 1 6	6	
B 8	SCC 1-3			Brake position (Cycle timer)	0 0 1 7	7	
B 12					+5V		
I/O 4	PANADAC 730-231 DC-5V-IN ST= C	A 13	OPC 4-7	Alarm	0 0 2 0	0	
		A 15	OPC12-2	Head rotation	0 0 2 1	1	
		A 16	OPC11-13	Insert	0 0 2 2	2	
		A 17	OPC11-12	Load (Semi auto)	0 0 2 3	3	
		A 18	OPC11-15	Inching ON	0 0 2 4	4	
		A 19	OPC11-14	Reset	0 0 2 5	5	
		A 20	OPC 4-14	Manual	0 0 2 6	6	
		A 21	OPC11-1	L rail (Manual)	0 0 2 7	7	
		A 22	OPC12-1		OV		
		I/O 4	PANADAC 730-231 DC-5V-IN ST= D	B 13	OPC11-5	U.L. rail	0 0 3 0
B 15	OPC11-2			L. belt	0 0 3 1	1	
B 16	OPC11-6			U.L. belt	0 0 3 2	2	
B 17	OPC11-3			Carry (Manual)	0 0 3 3	3	
B 18	OPC11-9			Feed	0 0 3 4	4	
B 19	OPC11-10			Guide	0 0 3 5	5	
B 20	OPC11-11			Supply	0 0 3 6	6	
B 21	OPC11-8			Rotation	0 0 3 7	7	
B							

PC board No.	PC board name	Pin connection	Connected to	Signal	Input address	I/O address	Remarks
I/O 5	PANADAC 730-231 DC-5V-IN ST= A	A 1	OPC11-7	Push arm (Planned)	0 0 4 0	0	
		A 2	OPC11-4	P.C.B. separate	0 0 4 1	1	
		A 3	P770 up SW	Awil short	0 0 4 2	2	
		A 4	SCC 3-3	Loader rail Traverse limit	0 0 4 3	3	
		A 5	SCC 3-4	Loader rail Return limit	0 0 4 4	4	
		A 6	SCC 2-3	Unloader rail Traverse limit	0 0 4 5	5	
		A 7	SCC 2-4	Unloader rail Return limit	0 0 4 6	6	
		A 8	OPC12-3	Hold	0 0 4 7	7	
		A 10	SCC 2-9		OV		
		I/O 5	PANADAC 730-231 DC-5V-IN ST= B	B 1	SCC 5-7	Positioner 1S	0 0 5 0
B 2	SCC 3-5			P.C.B. detection 1	0 0 5 1	1	
B 3	SCC 3-6			P.C.B. detection 2	0 0 5 2	2	
B 4	SCC 2-5			P.C.B. detection 3	0 0 5 3	3	
B 5	SCC 2-6			P.C.B. detection 4	0 0 5 4	4	
B 6	SCC11-9			Guide Up limit	0 0 5 5	5	
B 7	SCC11-10			Guide Down limit	0 0 5 6	6	
B 8	SCC11-13			Air down input	0 0 5 7	7	
B 12	SCC 1-7				+5V		
I/O 5	PANADAC 730-231 DC-5V-IN ST= C	A 13	SCC 5-5	Insertion check 1	0 0 6 0	0	
		A 15	SCC 5-6	Insertion check 2	0 0 6 1	1	
		A 16	SCC 1-10	Parts detection	0 0 6 2	2	
		A 17	SCC 6-4	Alarm input (Timer output)	0 0 6 3	3	
		A 18	SCC 3-13	P.C.B. sup. ready signal (L)	0 0 6 4	4	
		A 19	SCC 2-13	Stocker ready signal (H)	0 0 6 5	5	
		A 20	SCC 2-7	Push arm Traverse limit	0 0 6 6	6	
		A 21	SCC 2-8	Push arm Return limit	0 0 6 7	7	
		A 22	SCC 1-5		OV		
		IFR 10	PANADAC -770-204 ST=			Timer 1 (Feed cycle)	0 0 7 0
				Timer 2	0 0 7 1	1	
				Timer 3 (Loader)	0 0 7 2	2	
				Timer 4 (Inching)	0 0 7 3	3	
				Timer 5	0 0 7 4	4	
				Counter	0 0 7 5	5	
					0 0 7 6	6	
					0 0 7 7	7	

Item	Item or Code No.	Material & Size	qt	Process	Remark
PROGRAM SHEET					
Assigned					
Drawn					
Traced					
Checked					
Approved					
				Name	S/C INPUT/OUTPUT TABLE 1/7
				No.	M 1 0 1 0 5 9 0 3 5 2
					0 5
					1 6
					2 7
					3 8
					4 9

Commercial Reference	Sym.	Date	Revision	Signed	Chk

PC board No.	PC board name	Pin connection	Connected to	Signal	Indirect address	I/O address	Remarks
I/O 9	PANADAC 730-204	B 1, 2	SEC 4- 9	Loader rail	CYL.	0 1 0 0	
		B 3, 4	SEC 4-10	Unloader rail	CYL.	0 1 0 1	
	AC-OUT =	B 5, 6	SEC 4-11	Baride	CYL.	0 1 0 2	
		B 7, 8	SEC 3- 2	Loader belt	Motor	0 1 0 3	
		B 15,16	SEC 2- 2	Unloader belt	Motor	0 1 0 4	
		B 17,18	SEC 4- 0	Supply	Motor	0 1 0 5	
		B 19,20	SEC 4-14	Alarm output (Pat. light)		0 1 0 6	
		B 21,22	SEC 6- 2	Alarm timer		0 1 0 7	
B 10,11	I.B. 5		ACTHROW				
I/O 10	PANADAC 730-204	B 1, 2	SEC 4- 6	Head rotation	CYL.	0 1 1 0	
		B 3, 4	SEC 4- 7	Arvil	CYL.	0 1 1 1	
	AC-OUT =	B 5, 6	SEC 4-15	Carry	CYL.	0 1 1 2	
		B 7, 8	SEC 4- 3	Feed	CYL.	0 1 1 3	
		B 15,16	SEC 4- 5	Jumpor hold	CYL.	0 1 1 4	
		B 17,18	SEC 4-12	P.C.B. separate	CYL.	0 1 1 5	
		B 19,20	SEC 4-13	Push arm		0 1 1 6	
		B 21,22	SEC 6- 1	Running hour meter		0 1 1 7	
B 10,11	I.B. 5		ACTHROW				
I/O 7	PANADAC 730-205	B 1, 2	SEC 1-14	Main clutch		0 1 2 0	
		B 3, 4	SEC 1-15	Main brake 1		0 1 2 1	
	DC-OUT =	B 5, 6	SEC 5- 2	Main brake 2		0 1 2 2	
		B 7, 8	OPC 2-13	P.C.B. counter		0 1 2 3	
		B 15,16	SEC 5- 9	Main brake 3		0 1 2 4	
		B 17,18	SEC 5-10	Main brake 4		0 1 2 5	
		B 19,20				0 1 2 6	
		B 21,22				0 1 2 7	
B 10,11	I.B. 9		IV				
I/O 1	PANADAC 730-232	A 1	OPC 2- 1	M.ORG (Monitor)		0 1 3 0	
		A 2	OPC 2- 2	P.C.B. stock (Monitor)		0 1 3 1	
	DC-M-OUT ST= A	A 3	OPC 2- 6	Arvil short (Monitor)		0 1 3 2	
		A 4	OPC 2- 3	Insert FRR (Monitor)		0 1 3 3	
		A 5	OPC 2- 4	Load FRR (Monitor)		0 1 3 4	
		A 6	OPC 2- 5	Air down		0 1 3 5	
		A 7	OPC 2- 9	Recovery OK (Monitor)		0 1 3 6	
		A 8	OPC 2- 7	Data load (Monitor)		0 1 3 7	
A							

PC board No.	PC board name	Pin connection	Connected to	Signal	Indirect address	I/O address	Remarks
I/O 1	PANADAC 730-232	B 1	OPC 2- 8	P.EHR (Monitor)		0 1 4 0	
		B 2				0 1 4 1	
	DC-M-OUT ST= B	B 3				0 1 4 2	
		B 4				0 1 4 3	
		B 5	SEC 3-16		Stocker rotation signal (I)	0 1 4 4	
		B 6	SEC 2-12		Stocker rotation signal (II)	0 1 4 5	
		B 7	SEC 3-15		P.C.B. sup. CYL. signal (I)	0 1 4 6	
		B 8	SEC 2-14		Push arm CYL. signal (II)	0 1 4 7	
B 14	OPC 2-10		+5V				
I/O 6	PANADAC 730-231			Use at option unit		0 1 5 0	
				Use at option unit		0 1 5 1	
	DC-5V-IN ST= D			Use at option unit		0 1 5 2	
				Use at option unit		0 1 5 3	
				Use at option unit		0 1 5 4	
				Use at option unit		0 1 5 5	
				Use at option unit		0 1 5 6	
				Use at option unit		0 1 5 7	
I/O 5	PANADAC 730-231	B 13	SEC 3- 7	P.C.B. sup. CR. traverse limit		0 1 6 0	
		B 15	SEC 3- 8	P.C.B. sup. CYL. return limit		0 1 6 1	
	DC-5V-IN ST= D	B 16	SEC11- 4	Arvil return limit		0 1 6 2	
		B 17	SEC11- 5	Arvil traverse limit		0 1 6 3	
		B 18	SEC11- 6	Head rotation return limit		0 1 6 4	
		B 19	SEC11- 7	Head rotation traverse limit		0 1 6 5	
		B 20	SEC 1- 8	Feed return limit		0 1 6 6	
		B 21	SEC 1- 9	Feed traverse limit		0 1 6 7	
B 22	SEC 3-10		IV				
I/O	PANADAC 730-					0 1 7 0	
						0 1 7 1	
	ST=					0 1 7 2	
						0 1 7 3	
						0 1 7 4	
						0 1 7 5	
						0 1 7 6	
						0 1 7 7	

Sym.	Item or Code No.	Material & Size	qt.	Process	Remark
PROGRAM SHEET					
Designed	Drawn	Traced	Checked	Approved	Name
					S/C INPUT/OUTPUT TABLE 2/7
No.	M 1 0 1 0 5 9 0 3 5 3				
					0 5 1 6 2 7 3 8 4 9

Commercial Reference	Sym.	Date	Revision	Signed	Chk

PC board No.	PC board name	Pin connection	Connected to	Signal	Indirect address	I/O address	Remarks
I/O 2	PANADAC 730-232 DC-M-OUT ST= A	/	/		0 2 0 0		
					0 2 0 1		
					0 2 0 2		
					0 2 0 3		
					0 2 0 4		
					0 2 0 5		
					0 2 0 6		
I/O 2	PANADAC 730-232 DC-M-OUT ST= B	/	/		0 2 1 0		
					0 2 1 1		
					0 2 1 2		
					0 2 1 3		
					0 2 1 4		
					0 2 1 5		
					0 2 1 6		
I/O 2	PANADAC 730-232 DC-M-OUT ST= C	/	/		0 2 2 0		
					0 2 2 1		
					0 2 2 2		
					0 2 2 3		
					0 2 2 4		
					0 2 2 5		
					0 2 2 6		
I/O 2	PANADAC 730-232 DC-M-OUT ST= D	/	/		0 2 3 0		
					0 2 3 1		
					0 2 3 2		
					0 2 3 3		
					0 2 3 4		
					0 2 3 5		
					0 2 3 6		

PC board No.	PC board name	Pin connection	Connected to	Signal	Indirect address	I/O address	Remarks
I/O	PANADAC 730- ST=	/	/		0 2 4 0		
					0 2 4 1		
					0 2 4 2		
					0 2 4 3		
					0 2 4 4		
					0 2 4 5		
					0 2 4 6		
I/O 5	PANADAC 730-231 DC-5V-IN ST= E	/	/	Use at option unit	0 2 5 0		
				Use at option unit	0 2 5 1		
				Use at option unit	0 2 5 2		
				Use at option unit	0 2 5 3		
				Use at option unit	0 2 5 4		
				Use at option unit	0 2 5 5		
				Use at option unit	0 2 5 6		
I/O 4	PANADAC 730-231 DC-5V-IN ST= E	/	/	Use at option unit	0 2 6 0		
				Use at option unit	0 2 6 1		
				Use at option unit	0 2 6 2		
				Use at option unit	0 2 6 3		
				Use at option unit	0 2 6 4		
				Use at option unit	0 2 6 5		
				Use at option unit	0 2 6 6		
I/O 6	PANADAC 730-231 DC-5V-IN ST= E	/	/	Use at option unit	0 2 7 0		
				Use at option unit	0 2 7 1		
				Use at option unit	0 2 7 2		
				Use at option unit	0 2 7 3		
				Use at option unit	0 2 7 4		

Sym	Item or Code No.	Material & Size	Q't	Process	Remarks
PROGRAM SHEET					
Name: S/C INPUT/OUTPUT TABLE 3/7					0 5
No. M 1 0 1 0 5 9 0 3 5 4					1 6
					2 7
					3 8
					4 9

Symbol	Sym.	Date	Revision	Signed / Check
	△			

PC board No.	PC board name	Pin connection	Connected to	Signal	Memory	Indirect address	I/O address	Remarks	
I/O	PANADAC 730-			Restart	Memory	1 0 0 0	0		
				Amendment start	Memory	1 0 0 0	1		
				Insertion action	Memory	1 0 0 0	2		
				Final insertion	Memory	1 0 0 0	3		
						1 0 0 0	4		
						1 0 0 0	5		
						1 0 0 0	6		
	ST=			Insertion check	Memory	1 0 0 0	7		
I/O	PANADAC 730-					1 0 1 0	0		
						1 0 1 1	1		
						1 0 1 2	2		
						1 0 1 3	3		
					Inching	Memory	1 0 1 4	4	
					Loader end	memory	1 0 1 5	5	
					Loader action	Memory	1 0 1 6	6	
	ST=			Number counter	Memory	1 0 1 7	7		
I/O	PANADAC 730-			1 block	Memory	1 0 2 0	0		
				M. end	Memory	1 0 2 1	1		
				X-Y table lock	Memory	1 0 2 2	2		
						1 0 2 3	3		
					Amendment action (insertion)	Memory	1 0 2 4	4	
						1 0 2 5	5		
						1 0 2 6	6		
	ST=			V.W interlock	Memory	1 0 2 7	7		
I/O	PANADAC 730-			Wire supply	Memory	1 0 3 0	0		
				Anvil short	Memory	1 0 3 1	1		
				P.C.B. transfer	Memory	1 0 3 2	2		
				Normal stop	Memory	1 0 3 3	3		
				Parts exhaust stop	Memory	1 0 3 4	4		
				Inler lock	Memory	1 0 3 5	5	△	
				Carry forward stop	Memory	1 0 3 6	6	△	
	ST=			Carry return stop	Memory	1 0 3 7	7	△	

PC board No.	PC board name	Pin connection	Connected to	Signal	Memory	Indirect address	I/O address	Remarks
I/O	PANADAC 730-					1 0 4 0	0	
						1 0 4 1	1	
						1 0 4 2	2	
						1 0 4 3	3	
						1 0 4 4	4	
						1 0 4 5	5	
						1 0 4 6	6	
	ST=			Insertion check	Memory	1 0 4 7	7	
I/O	PANADAC 730-					1 0 5 0	0	
						1 0 5 1	1	
						1 0 5 2	2	
						1 0 5 3	3	
						1 0 5 4	4	
						1 0 5 5	5	
						1 0 5 6	6	
	ST=				Memory	1 0 5 7	7	
I/O	PANADAC 730-					1 0 6 0	0	
						1 0 6 1	1	
						1 0 6 2	2	
						1 0 6 3	3	
						1 0 6 4	4	
						1 0 6 5	5	
						1 0 6 6	6	
	ST=				Memory	1 0 6 7	7	
I/O	PANADAC 730-					1 0 7 0	0	
						1 0 7 1	1	
						1 0 7 2	2	
						1 0 7 3	3	
						1 0 7 4	4	
						1 0 7 5	5	
						1 0 7 6	6	
	ST=			F.C.D. 14/11/85 L.S. 11/11	Memory	1 0 7 7	7	

Sym.	Item or Code No.	Material & Size	qt.	Process	Remark
PROGRAM SHEET					
Name					S/C INPUT/OUTPUT TABLE 5/7
Designed	左藤	Drawn	Traced	Checked	田中
No.					M 1 0 1 0 5 9 0 3 5 6
					0 5
					1 6
					2 7
					3 8
					4 9

Contract Reference	Sym.	Date	Revision	Signal	Ch

NC UNIT → SC UNIT
(CAPABLE OF MONITORING)

PC board No.	PC board name	Pin connection	Connected to	Signal	Indirect address	I/O address	Remarks
I/O	PANADAC 730-	/	/		2 0 0 0	0	
					2 0 0 1	1	
					2 0 0 2	2	
					2 0 0 3	3	
					2 0 0 4	4	
					2 0 0 5	5	
					2 0 0 6	6	
					2 0 0 7	7	
I/O	PANADAC 730-	/	/	1 } / command (octal digit)	2 0 1 0	0	
				2 }	2 0 1 1	1	
				1 } B command (octal digit)	2 0 1 2	2	
				2 }	2 0 1 3	3	
				W slow down	2 0 1 4	4	
					2 0 1 5	5	
					2 0 1 6	6	
					2 0 1 7	7	
I/O	PANADAC 730-	/	/	1 }	2 0 2 0	0	
				2 }	2 0 2 1	1	
				4 } / command (octal digit)	2 0 2 2	2	
				10 }	2 0 2 3	3	
				20 }	2 0 2 4	4	
				40 }	2 0 2 5	5	
				V slow down	2 0 2 6	6	
					2 0 2 7	7	
I/O	PANADAC 730-	/	/	1 }	2 0 3 0	0	
				2 }	2 0 3 1	1	
				4 }	2 0 3 2	2	
				10 } B command (octal digit)	2 0 3 3	3	
				20 }	2 0 3 4	4	
				40 }	2 0 3 5	5	
				100 }	2 0 3 6	6	
					2 0 3 7	7	

PC board No.	PC board name	Pin connection	Connected to	Signal	Indirect address	I/O address	Remarks
I/O	PANADAC 730-	/	/	X. run	2 0 4 0	0	
				V. run	2 0 4 1	1	
				X. origin	2 0 4 2	2	
				Feeder carriage →	2 0 4 3	3	
				Feeder carriage ←	2 0 4 4	4	
				X.P. end	2 0 4 5	5	
				P. ERR	2 0 4 6	6	
				V.P. end	2 0 4 7	7	
I/O	PANADAC 730-	/	/	Y. run	2 0 5 0	0	
				W. run	2 0 5 1	1	
				Y. origin	2 0 5 2	2	
				V. origin	2 0 5 3	3	
				W. origin	2 0 5 4	4	
				Y.P. end	2 0 5 5	5	
					2 0 5 6	6	
				W.P. end	2 0 5 7	7	
I/O	PANADAC 730-	/	/	Z. run	2 0 6 0	0	
				Z. slow down	2 0 6 1	1	
				Z. origin	2 0 6 2	2	
					2 0 6 3	3	
					2 0 6 4	4	
				Z.P. end	2 0 6 5	5	
					2 0 6 6	6	
				During data load	2 0 6 7	7	
I/O	PANADAC 730-	/	/	Start signal	2 0 7 0	0	
				1 block signal	2 0 7 1	1	
				Recovery signal	2 0 7 2	2	
				Reset signal	2 0 7 3	3	
				Loader stocker P.C.B. take out signal	2 0 7 4	4	
				X-Y table P.C.B. take out signal	2 0 7 5	5	
				U.I. stacks negative return signal	2 0 7 6	6	
				Halt signal	2 0 7 7	7	

Sum	Item or Code No.	Material & Size	Qty	Process	Remark
PROGRAM SHEET					
Designed	Drawn	Traced	Checked	Approved	Name
					S/C INPUT/OUTPUT TABLE 6/7
					No. M 1 0 1 0 5 9 0 3 5 7
					0 5
					1 6
					2 7
					3 8
					4 9

Revision	Date	Drawn	Checked	Signed	Lib

SC UNIT → NC UNIT
(INCAPABLE OF MONITORING)

PC board No.	PC board name	Pin connection	Connected to	Signal	Indirect address	I/O address	Remarks
I/O	PANADAC 730-	/	/		2 0 0	0	
					2 0 0	1	
					2 0 0	2	
					2 0 0	3	
					2 0 0	4	
					2 0 0	5	
					2 0 0	6	
ST=				2 0 0	7		
I/O	PANADAC 730-	/	/		2 0 1	0	
					2 0 1	1	
					2 0 1	2	
					2 0 1	3	
					2 0 1	4	
					2 0 1	5	
					2 0 1	6	
ST=				2 0 1	7		
I/O	PANADAC 730-	/	/	Error time up (Pat. light)	2 0 2	0	
				Amendment start Information	2 0 2	1	
					2 0 2	2	
					2 0 2	3	
					2 0 2	4	
					2 0 2	5	
					2 0 2	6	
ST=				2 0 2	7		
I/O	PANADAC 730-	/	/	Cut miss Information	2 0 3	0	
				Start response Information	2 0 3	1	
				Stop response Information	2 0 3	2	
				EOP stop signal	2 0 3	3	
				Amendment OK	2 0 3	4	
				Amendment NG	2 0 3	5	
				P.C.B. stock (monitor) Information	2 0 3	6	
P.C.B. loading wait Information	2 0 3	7					
ST=							

PC board No.	PC board name	Pin connection	Connected to	Signal	Indirect address	I/O address	Remarks
I/O	PANADAC 730-	/	/	P.C.B. detection 5	2 0 4	0	
				Servo lock release	2 0 4	1	
				P.C.B. detection 6	2 0 4	2	
					2 0 4	3	
				P.C.B. guide error Information	2 0 4	4	
				Insertion miss Information	2 0 4	5	
				Anvil short Information	2 0 4	6	
Parts empty Information	2 0 4	7					
ST=							
I/O	PANADAC 730-	/	/	X axis lock	2 0 5	0	
				Y axis lock	2 0 5	1	
				Z axis lock	2 0 5	2	
				Operation start	2 0 5	3	
				Semi auto	2 0 5	4	
				Full auto	2 0 5	5	
				1. block	2 0 5	6	
M. end	2 0 5	7					
ST=							
I/O	PANADAC 730-	/	/	Recovery	2 0 6	0	
				Amendment Z axis return	2 0 6	1	
				Loader end	2 0 6	2	
				Feeder carriage +	2 0 6	3	
				Feeder carriage -	2 0 6	4	
				/1 block delete	2 0 6	5	
				/2 block delete	2 0 6	6	
/3 block delete	2 0 6	7					
ST=							
I/O	PANADAC 730-	/	/		2 0 7	0	
					2 0 7	1	
					2 0 7	2	
					2 0 7	3	
					2 0 7	4	
					2 0 7	5	
					2 0 7	6	
	2 0 7	7					
ST=							

Sm.	Item or Code No.	Material & Size	qt.	Process	Remark
PROGRAM SHEET					
Designed	Drawn	Traced	Checked	Approved	Name
					S/C INPUT/OUTPUT TABLE 7/7
No.	M 1 0 1 0 5 - 9 0 3 5 8				0 5
					1 6
					2 7
					3 8
					4 9

ACIN 3P Male

1	AC100V H
2	AC100V L
3	E

STY 15P Fem.

1	OV
2	Safety input 1 a
3	OV
4	Safety input 1 b
5	OV
6	Safety input 2 a
7	OV
8	Safety input 2 b
9	
10	
11	OV
12	ES SW
13	
14	ES Output
15	ES Output

SLM 15P Fem.

1	XY Safety limit
2	XY Safety limit
3	Z Safety limit
4	Z Safety limit
5	
6	X-Y Reset
7	X-Y Reset
8	Z Reset
9	Z Reset
10	SC Input
11	SC Input
12	
13	
14	Start Output
15	Start Output

PLEC 15P Fem.

1	
2	
3	ES SW(Main control panel)
4	ES SW(Main control panel)
5	
13	
14	OV
15	Start

ACIN

1
2
3

STY

1
2
3
4
5
6
7
8
9
10
11
12
13
14
15

SLM

1
2
3
4
5
6
7
8
9
10
11
12
13
14
15

PLEC

1
2
3
4
5
13
14
15

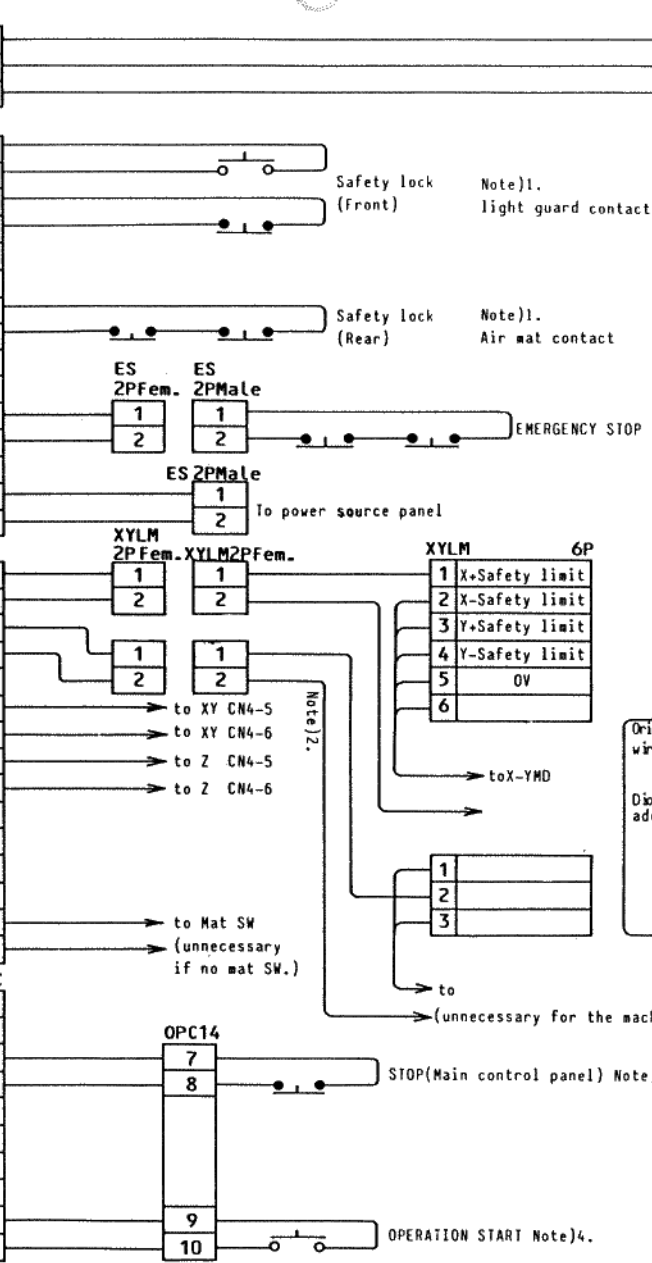

ACIN

1
2
3

To power source panel(100V should be supplied with power ON.)

Note)

Note)1. light guard contact

Note)3. Wiring for (EMERGENCY) STOP is modified.

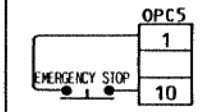

Don't use original SW wiring. Short-circuit OPC5-1 and OPC5-10.

Note)4. Wiring is added for OPERATION START.

For the machine with REAR OP panel, wiring is as follows.

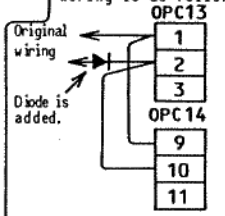

Note)1.

If safety lock is L.S.

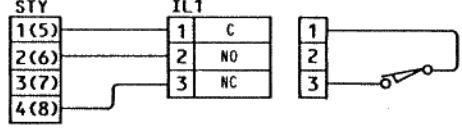

If there are more than two L.Ss.

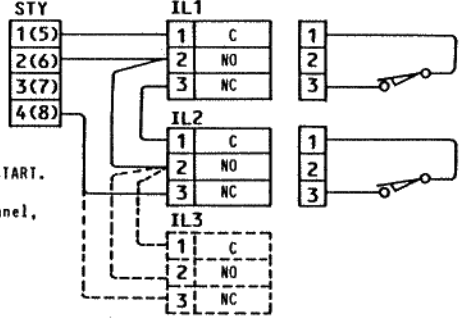

If safety lock is attached at either one position of REAR or FRONT, short-circuit STY-3 and -4(-7 and -8).

Note)Modification within MD is required.

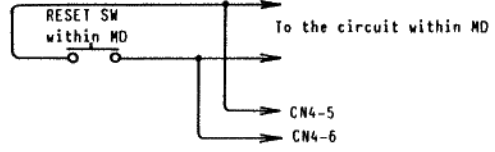

Sym.	Item or Code No.	Material & Size	qt.	Process	Remark
------	------------------	-----------------	-----	---------	--------

Scale	Designed	Drawn	Checked	Approved	Wiring Diagram for Safety Guard
					No. M 10-13 3-9 0-533

Matsushita Electric Industrial Co., Ltd.
Manufacturing Equipment Division