

BUILD YOUR OWN
METAL WORKING SHOP FROM SCRAP

2

The Metal Lathe

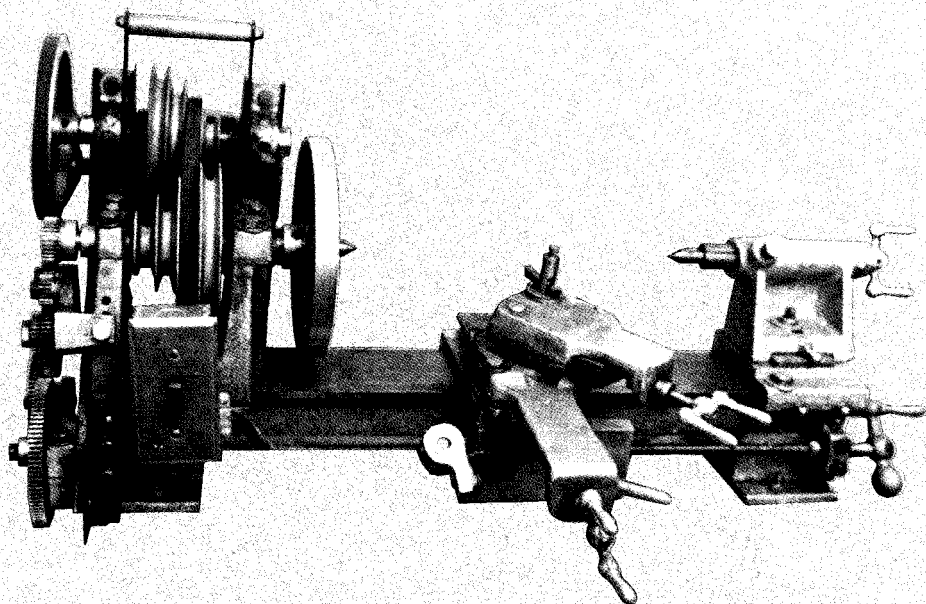

Written and Illustrated by David J. Gingery

Having been described as "the only machine that can duplicate itself or any other machine in the shop", the metal lathe is the most versatile and desirable of all metal working machine tools. It is certainly among the most expensive pieces of equipment, but there is no need to do without one in your shop because here is a lathe that can not only duplicate itself, but it can produce its own original parts from home made castings and stock materials. A fascinating project from its simple wooden patterns through finished castings and finally a complete machine. You will master many basic skills as you progress.

The basic machine described in this manual has a compound slide rest, belt powered lead screw, split nut carriage feed, adjustable gibs in sliding members and adjustable tailstock set over for taper turning. With its 7" swing and between centers capacity of 12", it provides the foundation for the complete home metal working shop. A machine you'll enjoy building and one you'll be as proud to own as any you might buy.

A later manual in the series will show you how to add change gears, a four jaw chuck, center steady rest and other very desirable and helpful accessories to your equipment. All you need to begin is the charcoal foundry and basic hand tools. The only power tool used to construct the original lathe seen in these photos was a 3/8" electric hand drill. All of the parts are machined on the lathe itself as it evolves. There is never a need to look for outside custom machine work.

How to make the patterns and how to mold them, how to use basic hand tools to prepare the castings for final finishing, and how to set them up for accurate machining on the developing lathe are all covered. The original lathe was used to machine a complete set of parts for a second identical machine, and so it not only duplicated itself but actually originated itself to a large extent. A delightful metal working project that provides a very thorough education and a sound and practical piece of shop equipment.

The "Build Your Own Metal Working Shop From Scrap" Series:

- Book 1 The Charcoal Foundry
- Book 2 The Metal Lathe
- Book 3 The Metal Shaper
- Book 4 The Milling Machine
- Book 5 The Drill Press
- Book 6 The Dividing Head & Deluxe Accessories
- Book 7 Designing & Building The Sheet Metal Brake

ISBN 1-878087-01-0



9 0 0 0 0



9 781878 087010

BUILD YOUR OWN
METAL WORKING SHOP FROM SCRAP
SERIES BOOK #2

THE METAL LATHE

Written & Illustrated
By
DAVID J. GINGERY

Printed in U. S. A.

Copyright ©1980 David J. Gingery
All rights reserved

Library Of Congress Catalog
Card Number 80-66142

ISBN 1-878087-01-0

David J. Gingery Publishing LLC
P.O. Box 318
Rogersville, MO 65742

<http://www.gingerybooks.com>
Email gingery@gingerybooks.com

CONTENTS

INTRODUCTION	5
CHAPTER I	
PREPARING TO BUILD.....	7
CHAPTER II	
FOUNDRY WORK.....	14
CHAPTER III	
BUILDING THE WAYS.....	17
CHAPTER IV	
THE CARRIAGE ASSEMBLY.....	28
CHAPTER V	
THE LEAD SCREW & SPLIT NUT MECHANISM.....	54
CHAPTER VI	
THE COUNTER SHAFT.....	70
CHAPTER VII	
THE HEAD STOCK.....	78
CHAPTER VIII	
THE LEAD SCREW DRIVE TRAIN.....	98
CHAPTER IX	
THE TAIL STOCK.....	101
CHAPTER X	
FINISHING & IMPROVING THE LATHE.....	115
CONCLUSION	126
INDEX	127

THE METHODS AND MATERIALS THAT ARE SUGGESTED IN THIS MANUAL. WERE DEVELOPED BY A NONPROFESSIONAL. THE AUTHOR IS NOT AN ENGINEER OR SCIENTIST. NO LIABILITY IS ASSUMED FOR INJURY TO PERSONS OR PROPERTY THAT MAY RESULT FROM THE USE OF THIS INFORMATION.

FOREWORD

The lathe that you see in the photograph below, was built as this manual was being prepared. There were no outside machining operations done on any of the parts. It was done with the methods described in these pages. The castings were made in green sand molds and the metal was melted in the Charcoal Foundry. While it may seem like an ambitious undertaking, it actually took less time to build the lathe than it took to write this manual. It has turned out to be the most satisfying project I've ever done.

Though based on my lifetime hobby, I was forced to pay attention to detail as I've never done before. There were so many changes in design and procedure, that the end product was a complete surprise to me. When you get into the details of its construction, you'll see what a remarkably simple machine it is. But, its appearance is impressive, it does not look like a homemade machine, and it performs, as well as it looks.

Presumably, if you are following the series, you will have established your compact home foundry. If you are new to metal casting you may feel a little intimidated in a strange activity. Some of your early castings may have failed in some way. If so, no doubt you have learned much about what caused the failure. It would take several hundred pages to deal with the subject in detail, (That is not to suggest that I know enough to write several hundred pages about foundry work), but you can learn far more as you work in it with your own hands. As you progress, you will gain skill and knowledge that will enable you to move beyond these simple methods, and do bigger and better projects.

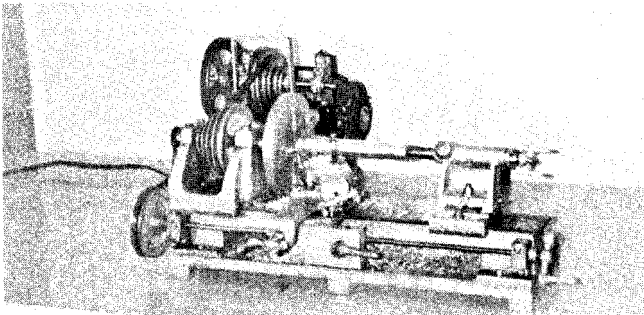

INTRODUCTION

The characteristic of a metal lathe that makes it so desirable is its versatility. It has been said that "the metal lathe is the only machine that can duplicate itself or any other machine in the shop." I'd like to be able to give credit to the originator of the statement, but I don't know who he is. In any case, it's a captivating thought which led me to ask whether a lathe could not only duplicate itself, but actually create itself.

I've spent a great deal of time over the past 25 or more years in finding the answer to the question. It has been a fascinating study with more failures than success.

It was not until I began to seriously consider castings that I realized any hope of succeeding. The simple art of sand casting was the break-through; and now that I have my portable foundry established, it's the most valuable equipment in my shop. Scrap aluminum is so abundant, and so easy to cast, that I find it hard to believe that it did not occur to me much earlier. It is easier than you ever dreamed, and it is the least expensive method to produce your own parts and working stock.

The answer to the question is an un-qualified yes, a metal lathe can create itself. It needs some help along the way, of course, and that's where you come into the act.

The photographs show the lathe as it developed during the preparation of this manual. The castings were poured in sand molds of the simplest type. The aluminum was melted in a one quart cast iron sauce pan, using the charcoal foundry. The only power tools that were used were a cheap 3/8" electric hand drill , a bench grinder, a table saw and, the horizontal disc grinder. There is no outside machine shop work, no welding; you can do it all yourself with the ordinary tools that are found in most shops.

Such exotic equipment as surface plates, dial gauges, etc. are not necessary. The entire project can be done without so much as a micrometer. The original lathe is a clear example. It turned its first test bar to a taper of .011". A slight adjustment to the tail stock set over was all that was needed to correct the taper to within .001". This qualifies it as a precision machine tool, and there were no precision tools used in its construction. I did not use the micrometer until the

test stage. The same test can be made with a \$2.00 flat leg caliper and a leaf type feeler gauge so, it is reasonable to say that you can build this lathe without owning any precision tools at all. No doubt, you'll want such instruments as time goes on; but, don't let the lack of them keep you from starting.

When seen completed, the lathe doesn't look as if it were hand made. Its appearance suggests that a great deal of skill is required to build it. The simple methods that are used here were developed with a very minimal amount of cash with the intention of proving that the basic hand skills of earlier times could be applied to material that has been discarded to produce machinery. While some of the methods are a little tedious, I had more time than money. Some procedures are a bit intricate such as the split nut casting, but it works very well, and any other method would be even more intricate, and very costly as well.

If you are completely new to metal working, it would be a help to do some supplemental reading before you get into the construction of the lathe. Much of the reference material I used in developing these projects is out of print and no longer easily available. Fortunately a number of great old manuals on metal working are available as reprints from Lindsay Publications, P.O. Box 538, Bradley, IL 60915-0538, You simply can't know too much, so do plenty of studying and reading and be patient with yourself as you digest information and master these many fascinating new skills.

While the projects are planned around the use of low melting alloys, such as aluminum and pot metal, I see no reason why they could not be carried out in grey iron if you have the equipment and the know how. Likewise if you have access to shop equipment, you can carry out some of the operations with greater ease and speed.

Though long abandoned and considered old fashioned, these methods are by no means unprofessional. As your shop develops, so will your skill and knowledge. Neither is of any value without the other. There are no failures in this project; just learning experiences. If you botch a casting, it's a small matter to make another. You will have gained the necessary knowledge to do it right so, it can hardly be counted a loss. Taken at a leisurely pace, it is a delightful project, that yields a piece of equipment that you can be proud to own, doubly so, because you have built it yourself.

CHAPTER I

PREPARING TO BUILD

A BRIEF HISTORY

All of us have seen the illustration of a caveman who has mounted a log on wooden centers between two trees. He has a rawhide thong wrapped around the log. One end is tied to a springy branch over his head, and the other end is tied to his instep or his great toe. He operates his lathe by pumping his foot up and down while he applies his hand held tools to the spinning log, sliding them along a hewn plank, which is his steady rest.

The picture may, be true or false I really don't know. If true, it is certain that there was no OSHA in those days.

It does illustrate the basic principle of a lathe; a concept that will be an aid in understanding what we are going to do. We are going to "evolve" a metal lathe.

The modern machine tools that are common in this age did not just appear, they evolved over centuries into the magnificent and complex devices that we know today. The most skilled machinist of 40 years ago would be a lost ball in tall weeds in a modern machine shop. But it was the skill and equipment of his time that built the wonders of this age.

It is the nature of a machine to demand improvement. As it develops and performs, it will fail in some way and thereby require that you do something to correct the problem. You can never be satisfied for long, so the procedure is begin and keep going.

There are some authentic drawings of the 16th and 17th century, showing "whip lathes" that operated like our cave mans lathe. An assistant manipulated the whip, or thong, while a craftsman applied his tools to the spinning work.

As recently as 40 years ago, you could still buy foot operated lathes that used a treadle and fly wheel, just as grandma's sewing machine.

It wasn't until 1740, that an unknown frenchman fitted a lead screw to a small lathe. Until then, it took a great deal of skill and patience to cut screw threads. It still required great skill to coordinate the lead screw with the spindle. Male and female threads had to be

custom fitted. Mass production of interchangeable parts was impossible.

In 1797 an Englishman, Henry Maudsley, connected the lead screw to the spindle with gears. Now it was possible to cut uniform threads, but the lead screw had to be changed to cut a different pitch.

It was not too long before someone devised a system of change gears, and throughout the past 200 years, progress has been made by leaps and bounds. But never fast enough to keep us satisfied.

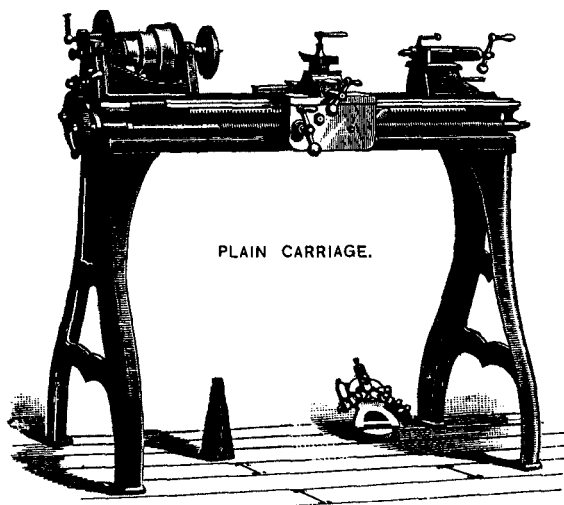

The illustrated lathe was made by F. E. Reed of Worcester, Mass., and sold by the Hill & Clarke Machinery Co. of Boston. It was available in 1888 for \$150.00 in the smallest size which was a 10" swing with 4-foot bed. It weighed 500 pounds. The price was the same whether line shaft driven or foot powered. A special countershaft was offered for foot power operation at \$12.00.

While this machine was of commercial manufacture, the methods used in its construction were very similar to the methods outlined in this manual. This machine was largely hand built.

Now, don't be alarmed. We are going to evolve a lathe, but we are not going to begin as our cave man friend. We have many advantages in standard materials that lie in the scrap heap. There is no need to spend a year or more to fashion a lead screw, as Maudsley

must have done, when we have threaded rod lying all around us. Cold rolled steel is produced to very close standards that require little work to make accurate ways for the bed and slides. Actually, most of our work is already finished; others have discarded what we need, and so, we can build our metal working machines from scrap.

The obvious lesson in the discussion of the development of the lathe is; There had to be a time when there was no lathe. This is the situation we now face in the home shop. But we can skip several centuries of blind struggle, and without risk to our instep or great toe, produce a practical lathe with what we have to begin with. If we select the right sequence of operations, we avoid going to the local machine shop for help in shaping the parts. The developing lathe will perform the needed operations to fit each part to its intended purpose. Each step in the construction will make the machine more useful. When this concept captures your imagination, you will see that there is no limit to the features you can add to the machine.

In its simplest form a lathe consists of a bed, a head stock, a tail stock, and a tool rest. Such a machine can be called primitive. It seems useless when compared to a modern full featured lathe, but the truth is; it is the heart of every lathe, and it can produce what is necessary for its own refinement. It is not difficult to construct a simple lathe.

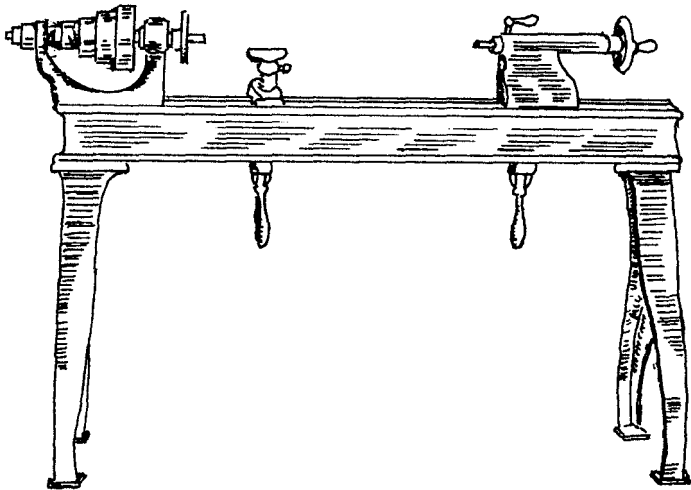

EQUIPMENT AND METHODS

The most important equipment is the foundry. We'll discuss that in some detail in the next chapter. For the best part, the main piece of equipment will be the lathe itself. For that reason, the sequence of operations is the first consideration.

The main challenge is in achieving near perfect alignment of the fundamental parts. The head stock is fastened permanently to the bed; it carries the spindle, which must be exactly parallel to the bed ways. The tail stock is to be moved to various positions along the ways, to accommodate different lengths of work, so the tail stock ram must be exactly parallel to the ways and, its center must be exactly the same as the head stock spindle. The carriage will travel along the ways to carry the cutting tool exactly parallel to the center line of the spindle and ram. With these principles understood it is plain that the bed is the first order of construction since all other work may be considered relative to it.

Building the bed is routine work. Ordinary wood working skill will get the job done. Only the simplest tools are required. Hand scraping is likely to be the only process that will be new to you. You will have no trouble in mastering this simple skill, and it will be of great value in all of your metal working activity.

When the bed is established, a stationary boring bar is improvised to bore the head stock. Since the head stock is fitted to the bed and made to travel it as it is bored, it will receive a pair of holes that are exactly parallel to the ways.

Once the head stock bore is established, it is fitted with the boring bar to bore the tail stock. As all boring is done on the same center and the work is made to travel the same ways, any error has to be minimal. It is a simple matter to correct it with the ample adjustment that is provided in the tail stock set over.

It is now a simple matter to fit temporary centers on which to produce the remaining parts.

Before we get into the actual construction, it will be a help to assume certain knowledge. I'll discuss some of the methods, and try to define some terms so that they can be referred to briefly in the main text.

HAND SCRAPING

This simple process has been referred to as the "Art of Hand scraping". It is well to remember that knowledge is generally passed on reluctantly. Those who know how want to maintain their superior position so they always try to make it as difficult as possible. It's up to you to discover the secret and avoid the diversions that such people want to set in your way.

The skill is so easy to acquire that it can hardly be called an "Art". Here's how it's done:

A test standard is selected which will represent the finished surface. Sometimes the standard will be the mating part such as the shaft that will fit a bearing. Or, it can be a precision surface plate, as used by die makers. No one in his right mind would lend you a surface plate, and they are too expensive, so we have to improvise. If you have a good quality bench level with milled surfaces, it will provide a test standard that is good enough for the work in this project.

An indicator color is wiped on the surface of the work so that high spots will be indicated when the test standard is applied. Bearing blue was used for generations. It is not generally available any more, but you can buy a small tube of Prussian blue oil paint from Wal-Mart or any art supply, and you have the same thing. I don't know if the new acrylic type will work as well, so you might better be safe and stick to the old fashioned oil paint.

The cutting tools are simple and in-expensive. Three cornered scrapers look like a three cornered file with no teeth. If the local industrial supply house doesn't have one, send \$1.00 for a catalog to U. S. General, 100 Commercial Street, Plainview, N. Y. 11803. They have a large line of tools including a three cornered scraper at about \$3.00. For aluminum, some of the scraping can be done by a good quality wood chisel with a well honed edge. Special shapes for hard to reach places can be made from an old file. The edge must be very straight and well honed.

A scraper works like a file with just one tooth. If the angle of the tool is correct, it will remove a large amount of metal as it is drawn over the work. It cuts a lot deeper than a file, so you can bring the surface down very rapidly.

The surface is semi-finished with a file to remove as much material as necessary so that the test standard will rest on it without rocking. The entire surface is coated with the Prussian Blue and wiped off to leave a stain. It dries very quickly, so you can rub the test standard on it right away. Don't rub hard, just two or three short strokes will do the job. The blue stain will be rubbed off of the high spots to indicate where to scrape. At first, there will be only a few small high spots, but as you progress, they increase in number and size. After each test, you scrape off the high spots, re-stain, and test again. It takes only a little study and practice to master it. With patience and skill you can reduce a surface to dead flat in a very short time. Dead flat would mean that all of the indicator would be rubbed off when you test. That kind of precision is not required for all work. In the case of the lathe bed, it is only necessary to provide about 75% contact between the top of the bed and the steel ways.

The steel slides are very close to dimension, so you don't have very much to remove. On the aluminum castings, you can remove drastic high spots with a very sharp wood chisel and a mallet. You can remove a 1/16" hump from the surface of aluminum, just about as easily as if it were a piece of hard wood. It won't harm a good quality chisel. A well honed scraper will bring down a steel surface very rapidly. The angle of the cut will determine its depth.

Like most hand skills, it requires only an understanding of the principle and a little practice. Call it an art if you want to, but if it is, the guy who operates the road grader is an artist too.

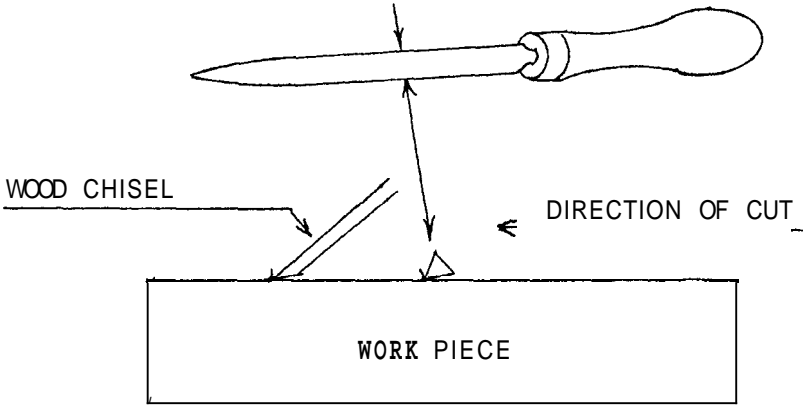

FILING

Aluminum is troublesome to file because it tends to clog up the teeth of the file. A very sharp pointed tool will remove the chips to clean up the file. A 14" lathe file which has a steeper angle to the teeth than a mill file will be the best type to use. Get one with at least one edge "safe". That means that the safe edge has no teeth; you can file in a corner without cutting the side.

HACKSAWING

A 24 tooth blade in a very rigid frame will do all of your cut off work. A flexible blade of high speed steel is worth the extra cost. Cheap blades will only frustrate you. Cut only on the forward stroke, and don't get in a hurry. One full length stroke per second will do the job a lot faster than short fast strokes.

DRILLING AND TAPPING

Use drills and taps of high speed steel. Cheap imported tools just won't do the job. They will usually not even complete a hole before they break or lose their edge.

Step drilling or concentric drilling means to begin with a small hole and enlarge it with progressively larger bits. It ensures that the hole will remain closer to its intended center, and it makes the work easier. In most cases a 1/8" drill makes a good pilot. The next step can be the tap size, and the final step the bolt size.

Without a drill press and a very accurate jig, it is very near impossible to drill mating members separately, and have the holes line up. The best way is; clamp the members together, drill the pilot and tap hole, separate the members, tap the threads in one member, and enlarge the mating holes to bolt size.

Use the correct size tap drill, or slightly larger, to avoid breaking taps in the work. Use plenty of oil, advance the tap in fractional turns and back it up from time to time, to clear away the chips.

When you join mating members with a row of screws, do one hole completely, and install the bolt before you do the rest of the holes, otherwise, the holes won't line up.

CHAPTER II

FOUNDRY WORK

Assuming that you have established a compact foundry to produce your castings, it is only necessary to clarify the terms that will be used.

The Charcoal Foundry was developed especially for this project. It was intended to be the simplest and least expensive way to get into metal casting. It is not difficult to produce the castings that are required.

PATTERN MAKING

Considerable detail is offered in the assembling of the patterns. I use white pine because it is straight grained, and easy to cut to size and shape. For thin section work, such as the bed pattern, use 1/4" exterior plywood if you don't have a table saw to rip the thin sections.

The most important details are the draft and parting line. A pattern is worthless if you can't get it out of the sand without destroying the cavity.

Sand the surface smooth, fill all flaws and form fillets on all inside corners. Outside corners are rounded, except at the parting plane on flat faced patterns. Seal with two coats of shellac, varnish or lacquer. All of this work is done to ensure that the pattern will release easily from the sand without damaging the cavity. Plastic auto body putty is a handy material for pattern making. Used to fill flaws and form fillets, it hardens quickly to wood like consistency.

The fillets which are the rounded junction between the members of an inside corner should be of small radius, to avoid increasing the weight of the section. A heavy corner can cause a shrink cavity or a tear in the casting.

Make your patterns as accurately as you can to avoid a tedious filing and scraping job later.

MOLDING

All of the molds are two part closed molds of green sand. The sequence of operations will vary, but each mold will require the same essential elements. I'll define a few terms that may not be clear to everyone. A blank cope or drag is a flask half that has been rammed fill of sand and struck off without using a pattern. It is made to provide a bed for a pattern that has no flat surface to lay on the molding board. In use, the pattern is pressed or rapped into the sand up to the parting line; the opposite half of the mold is rammed over the bedded pattern. It is generally an easier method than making a follow board for the same purpose.

A false cope or drag, is a blank half that is shaken out and re-made before the mold is poured. If the bedded portion of the pattern is simple in shape and shallow, it may provide a faithful enough cavity with simple bedding. Otherwise, the bedding half of the mold is shaken out and re-made.

Two, or sometimes three, rolls are used to bring the cavity or core to the correct position for pouring. Called a double or triple roll, it is used mostly with castings that have a large green sand core which must rest on the drag to prevent its falling into the cavity.

A green sand core is formed as a part of the entire mold when it is rammed up. The term means any part of the mold which forms a hollow portion of the casting.

To bed a pattern means to press or rap it into the surface of a blank cope or drag.

To ram up a mold includes all of the following:

1. Lay the pattern on the molding board and dust it with parting compound.
2. Set the flask over the pattern, and ram it fill of sand.
3. Strike it off level and vent the mold with the wire.
4. Rub in the bottom board, roll over the flask, and remove the molding board.
5. Dust the parting face with parting compound, and set the cope in place.
6. Set the sprue pin and ram the cope fill of sand.

7. Vent the cope with the wire, remove the sprue pin, and open the mold.
8. Cut the gates from the sprue print to the cavity.
9. Swab the pattern, rap it, and draw it from the mold.
10. Clean up the cavity, and close up the mold.

The sequence will vary but, all of these steps must be carried out in each mold. Variations will be discussed in detail in the text.

MELTING WITH THE CHARCOAL FOUNDRY

The size of the lathe in this manual was determined by the maximum capacity of the one quart cast iron sauce pan that is used in the charcoal foundry.

Only four of the castings are other than routine. It will require a near brim full pot to pour the bed casting and the head stock casting. This is a dangerous practice for any one. For this reason, you should pour some of the smaller molds to gain skill and confidence before you attempt to handle the full pot.

Because the pot rests on the fuel bed in the charcoal furnace, it requires close attention to avoid spilling as the bed settles. It becomes necessary to remove the pot to level the fuel bed from time to time. It is difficult to grasp the pot with the tongs, to remove it from the furnace, so I use a pair of long angle nosed pliers on the rim of the pot. I keep a pair of bricks near the furnace to set the lid on, and I set the pot on the lid while I level the fuel bed or add more charcoal. It also puts the pot in a good position to grasp it with the tongs if I'm ready to pour. I wear heavy welder's gloves when ever I melt. It may be possible to pour a mold with the pot held in the pliers, but I think it a bad idea. The heat may well penetrate the glove before you are done. Handling molten metal is a very serious business, be very sure of your equipment and your ability.

All of the castings, with the exception of the split nut and the tail stock, can be made before you begin building, but I think it a better idea to make them as you go along to lend a little variety and interest to the work.

There should be nothing to stop you now, so let's go to work and build a lathe.

CHAPTER III

BUILDING THE BED AND WAYS

While the ways of the lathe are a single slab of cold rolled steel, they must be thought of as being divided. The edge facing you as you operate the lathe is the front way, the far edge is the back way. When making a cut, most of the strain is on the back way; it will determine the path of the carriage and the accuracy of the lathe.

The bed supports the ways, so its top surface must be very true and flat.

THE BED PATTERNS

There are three castings in the bed, but only two patterns are required since the mounting bases are duplicates.

The drawings below are meant to represent the bed castings, not the patterns. This is to give you a general idea of what you are going to make.

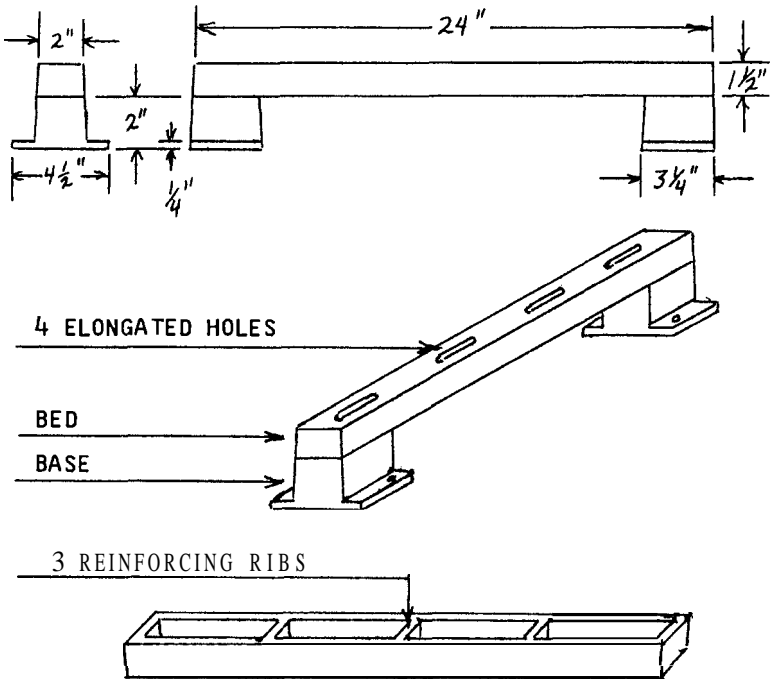

Notice that the bed is hollow, and it has three reinforcing ribs in the hollow portion. The ribs form separate cores which make up the hollow. This will have to be a double roll mold so that the four separate cores will rest on the face of the drag. The mounting bases are hollow, but they have no ribs.

The four elongated holes in the top of the bed serve a two fold purpose. They are used to bolt the steel ways to the bed, and they serve as vents for the cores when the mold is poured.

The bed casting will shrink about $3/8$ " in length so, the pattern will be $24\text{-}3/8$ " long to allow for the shrinkage. The height and width won't shrink enough to cause concern, so no allowance is made.

Even if you are going to cast the bed later on, make the pattern at this time, so you can fit the mounting base pattern to it. The base will shrink in the same proportion as the bed, so if the patterns fit together, so will the castings.

The sectional drawing on page 18 shows the method for fastening the castings to each other and to the steel ways. The ways are bolted

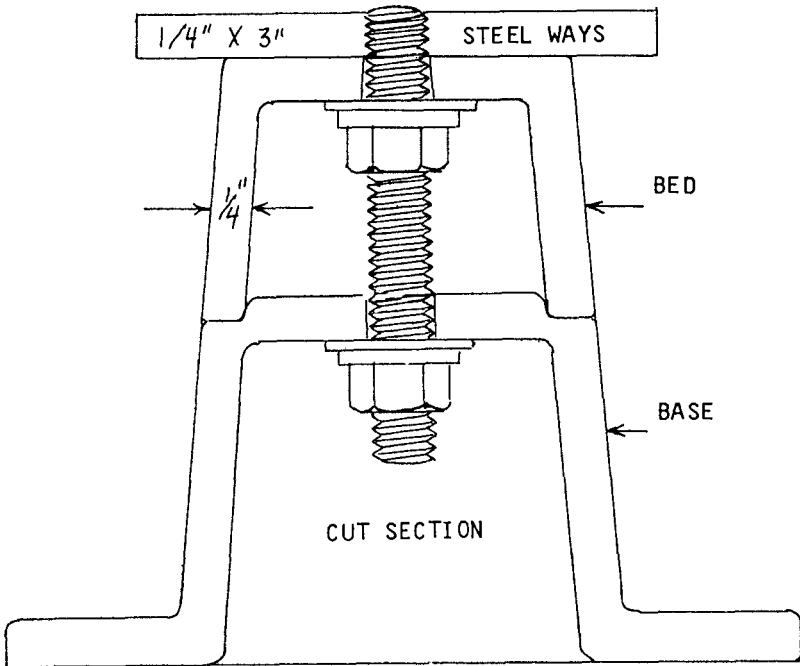

to the bed with two 3/8"-16 cap screws through the elongated holes in the center of the bed. The end holes use two 3/8"-16 studs, which also pass through the mounting base casting to fasten it to the bed. Flat washers and lock washers are used on all four positions.

Notice the raised shoulder on the top of the mounting base which mates with the bottom of the bed casting. This is the area where the patterns should fit nicely.

The patterns have been designed with an extra amount of draft to make it easy to draw them from the mold. The section thickness is 1/4" throughout, except for the ribs, which taper from 1/4" at the top to 3/16" at the bottom. It is important to install the ribs with their center line at exactly right angles to the horizontal line of the bed. If they are installed at a slant, the benefit of the draft will be lost; one or more of the cores will lock the pattern in the sand.

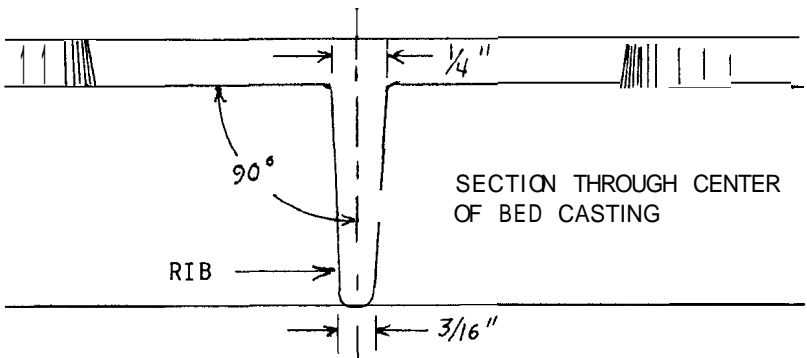

The sectional view shows the bed as though it were cut in half along the center. The shape and position of the rib is seen, and so is the center of the elongated holes. The elongated holes must have extra draft so that they remain in the drag as a part of the main green sand cores.

1/4" plywood will serve to make the sides and top of the bed pattern, but the end sections and the ribs will be best made of white pine. The end sections are not tapered like the ribs because they are set at an angle to provide draft both inside and out.

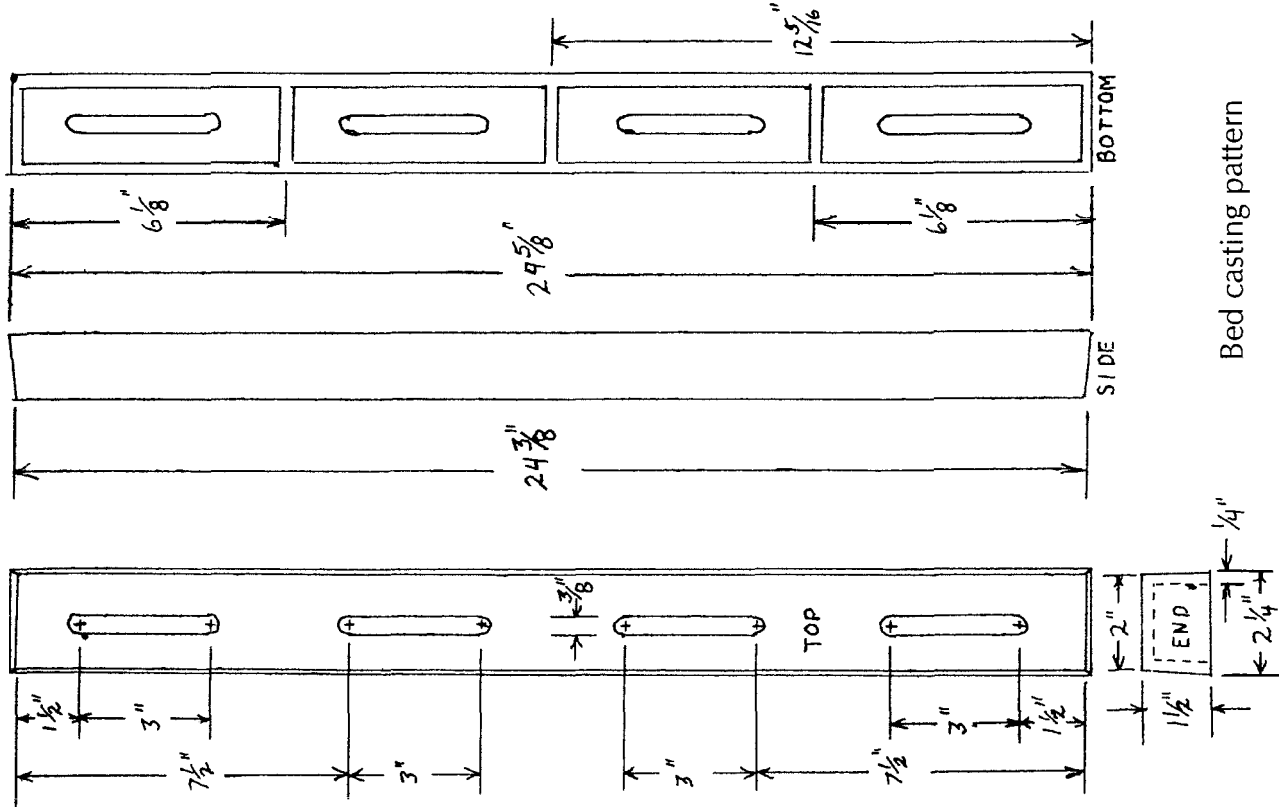

Bed casting pattern

ACCURACY STARTS HERE

To avoid a tedious scraping and filing job on the casting, make sure that your pattern is straight and true. The top surface of the bed must be as near true flat as you can manage. A milled surface, such as the table of the saw or a milled carpenter's level, will provide a good standard to test the trueness of the surface.

The easiest method is to make the main body of the pattern as a box with sloping sides. Then, add the ribs and cut the elongated holes in the top. You can locate the centers from the plan; drill two 3/8" holes for each slot, and cut the slots with a jig saw or coping saw.

The fillets on the inside corners can be formed with a 1/8" or 3/16" rod, with the end ground to a smooth round. Bend a right angle on the end of the rod so you can get into close places. All inside corners are rounded or filleted, and all outside corners are rounded except at the parting plane. Plastic auto body putty is ideal for filleting.

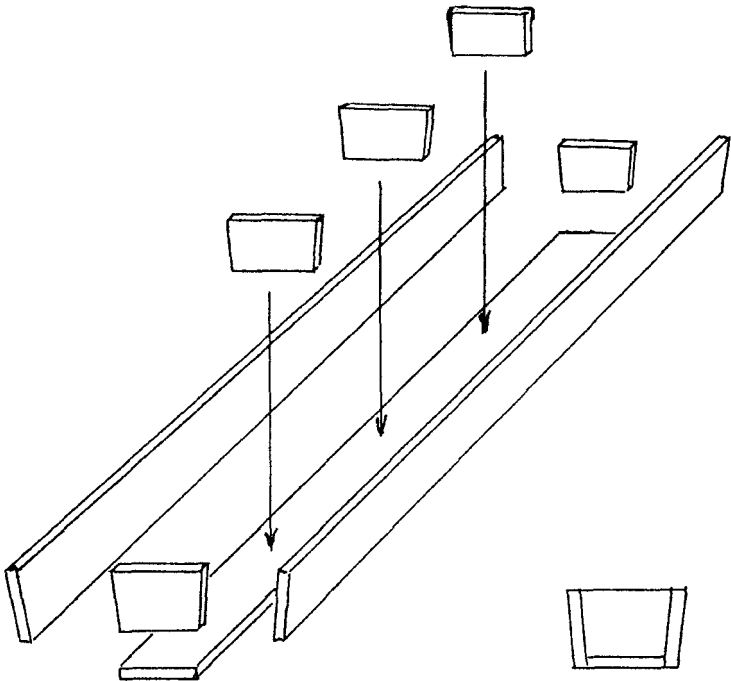

I keep 16 gauge sheet metal on hand so I can make any shape of scraper that I might need to clean up the inside surface of such patterns. Cut to rough shape with a hacksaw, and finished with a file, they make handy tools.

A SPECIAL FLASK IS REQUIRED

We'll discuss the molding of this pattern in considerable detail, which will also lay a foundation for other molding problems as they arise. It won't be necessary to say as much about the other molds.

Because of its length, the mold for this pattern requires a special flask.

The drag is no problem at all, since you have the molding board and the bottom board to support the sand when the flask is moved or rolled over. It requires a single rib in the center, to keep it from spreading apart when the sand is rammed in.

The main problem is in the cope; because when you lift it to remove the pattern, the sand will fall out in a heap, unless you provide ribs to support it.

The drawing will show the details of construction, as well as the dimensions.

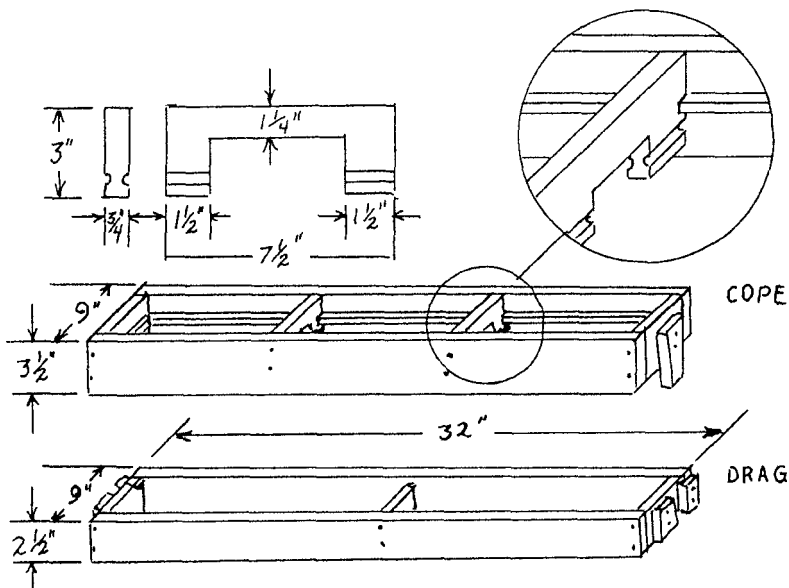

The flask is made of ordinary 3/4" lumber. The size is approximate since it is only necessary to surround the pattern with about 2" of sand. I deliberately sized it to be smaller than usual practice would dictate, because it is pretty heavy to handle when it is rammed full. The drag is 1" smaller in depth than the cope, because there is no need to handle the extra weight in sand.

The rib in the drag is only to keep it from spreading apart when the sand is rammed in. It is installed in the center of the drag and its top edge is 1/2" below the top edge of the sides of the flask.

The ribs in the cope will divide it into three separate bodies of sand. The magnified view of the rib will show you that a 1/4" groove is cut in each side near the bottom of the rib. This is to give it a grip on the sand.

The cut-out in the center of the rib will clear the pattern by about an inch on each side, so that it will be completely surrounded with sand.

The 1/4" square bead, that is nailed inside the cope, is also to give the flask a grip on the sand so it won't fall out when you open the mold.

Square the ends of the stock so that the halves of the flask will fit well at the parting plane. Assemble it with nails and glue, and give it a coat of lacquer or varnish. Make sure that the two halves will separate smoothly, with no side play in the alignment pegs.

MOLDING THE BED CASTING

This mold will be rolled over twice, to finish with the pattern bedded in the cope, and the green sand cores will rest on the face of the drag.

Begin by preparing a molding board that will fit between the alignment pegs on the cope. The pattern is set on the molding board with its normal top side up. The four elongated holes are covered with a length of thin tape, to provide a barrier between the cope sand and the small cores that will be left by the holes. We want the cores to be a part of the main cores that form the hollow portion of the bed. It is best if the tape covers the entire top of the pattern; the new clear plastic packaging tape is very good for this purpose. Being very thin and strong, it is just the right width to do the job.

Dust the pattern with parting and set the cope on the molding board. Center the pattern in the tunnel that is formed by the ribs, set a 1" sprue pin in the center of the pattern, and ram up the cope. Use special care to ram thoroughly, especially in the corners. Do it in several layers so there will be no voids.

Remove the sprue pin and rub in a bottom board before you make the first roll. Don't forget to vent generously with the wire.

When you roll the cope over, and remove the molding board, you will see the core cavity of the pattern.

Leaving the pattern in place, dust the entire parting face and pattern, set the drag in place, and ram it up.

Vent the drag with the wire, rub in the bottom board and make the second roll.

Slip the sprue pin back into the sprue and give it a rap or two, to free the pattern from the cope sand.

Lift the cope straight up, and set it on edge behind the drag.

The pattern will be resting on the parting face of the drag. Just rap it all around and lift it straight up.

The cores will be resting on the drag, and the cavity will be in the cope. Just pull out the sprue pin, carve it to a funnel shape, and the mold is ready to blow off and close up.

You have created a masterpiece, and destroyed your nerves. Go have a cup of coffee, or what ever you drink at times like this, and rest for a while.

POURING THE BED CASTING

This mold is pretty heavy when assembled, so to make it a little easier on yourself, carry the drag out and set it level, then carry the cope out and close up the mold just before you pour.

As mentioned earlier, this mold will use the full capacity of the charcoal foundry using the one quart cast iron pot. Be very careful in this, and all pouring operations.

A single pop gate is used because of the limited capacity, but it works very well if the mold is filled as fast as the sprue will accept the metal. To pour too slowly, or worse yet, to interrupt the pour, is certain to spoil the casting. Allow this casting to cool for at least an hour before shaking it out.

INSTALLING THE WAYS

When the casting has cooled, saw off the sprue, clean up any fins or rough edges, and prepare it for the scraping operation as described in chapter I. Since the ways will follow the surface of the bed, it is very important that it is as straight as you can make it.

The ways are of a single slab of 1/4" X 3" cold rolled steel, 24" long. If you must buy it from a steel supply house, have it saw cut instead of torch cut. If you can't avoid a torch cut, get it about 6" longer, and cut it square on both ends with a hack saw.

Cold rolled steel is identifiable by its smooth surface. Hot rolled steel has a scaly surface, as seen on angle iron and other structural steel shapes. As it leaves the mill, cold rolled steel is accurate to within .003" to .005". Unless it has been deformed in storage or handling, it makes satisfactory stock for this purpose,

Before it is installed on the bed, the back ways must be brought to as near dead flat as possible. Test both of the edges, and choose the truest one for the back ways.

Using the methods described in chapter I, scrape the back ways until they are satisfactory. This does not mean absolute perfection; minor flaws are tolerable because the carriage will span 3" of the length. The important thing is; to provide a straight edge to guide the carriage. Any drastic curves or dips in the edge will be repeated in the work you do on the lathe.

Simply clamp the ways in the vise, wipe on the prussian blue, scrape off the high spots, and test again. It won't take long, since the surface is only 1/4" wide. The front ways will be scraped parallel to the back ways when the carriage is built.

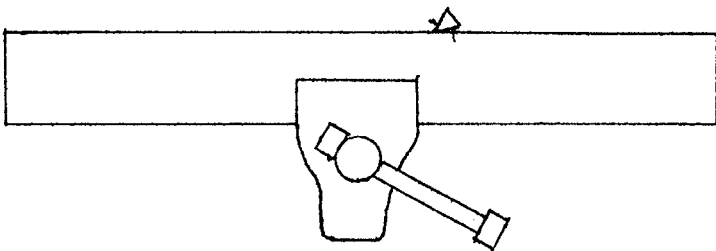

The ways are bolted to the bed with two 318"-16 cap screws through the middle elongated holes, and with two 318"-16 studs through the end elongated holes. The studs can be made of threaded rod. The stud for the tail stock end is 2-1/2" long. The one for the head stock end is 3-1/4" long, because it will be used to anchor the headstock when it is permanently installed.

Locate the hole centers on the steel ways, step drill them to 5/16", and tap them for 3/8"-16 threads.

The ways must over-hang equally, both front and back. It may be necessary to widen the elongated holes to center them on the bed.

Install two 318"-16 X 3/4" cap screws, with flat washers and lock washers, in the middle holes. Leave all bolts loose until the ways are centered. Install the studs, with flat washers, lock washers and hex nuts, in the two end holes. Align the ways to the bed, and tighten down the bolts and nuts. It doesn't matter if the ends of the bolts protrude above the ways a slight amount. If it is more than 1/16", add another flat washer.

The mounting bases are fastened to the bed with the two end studs, and they are the next order of construction.

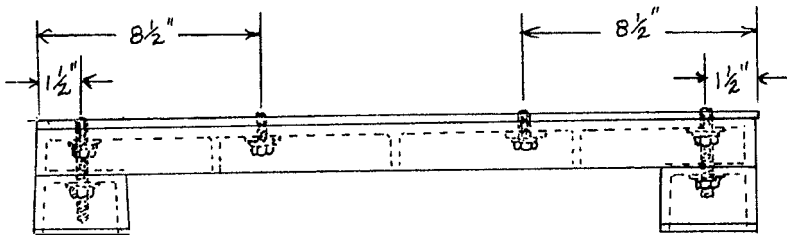

If the bed is slightly shorter than the ways, let the ways hang over the bed on the tail stock end.

When assembly is complete, the bed should rest on a flat surface without rocking. If necessary, alter the joint between the base and the bed by filing. If it does not rest flat, the bed will be forced out of true when it is bolted to its permanent mounting place.

If you have done your work carefully, the bed will be a very accurate and useful tool in the remaining work.

The job will be more interesting from now on.

THE MOUNTING BASES

Although there are two bases, only one pattern is required because they are duplicates.

Being hollow, with a 1/4" section thickness like the bed, they are made up in the same manner, and molded with a double roll. Use a 1" sprue in the center of the top.

The raised portion on the top surface provides a shoulder that registers with the bottom of the bed.

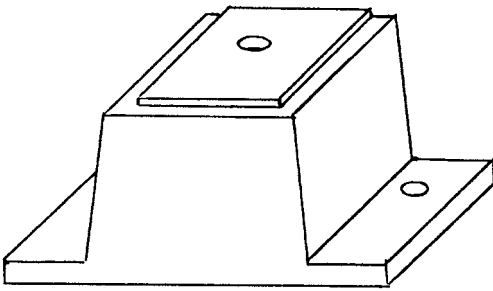
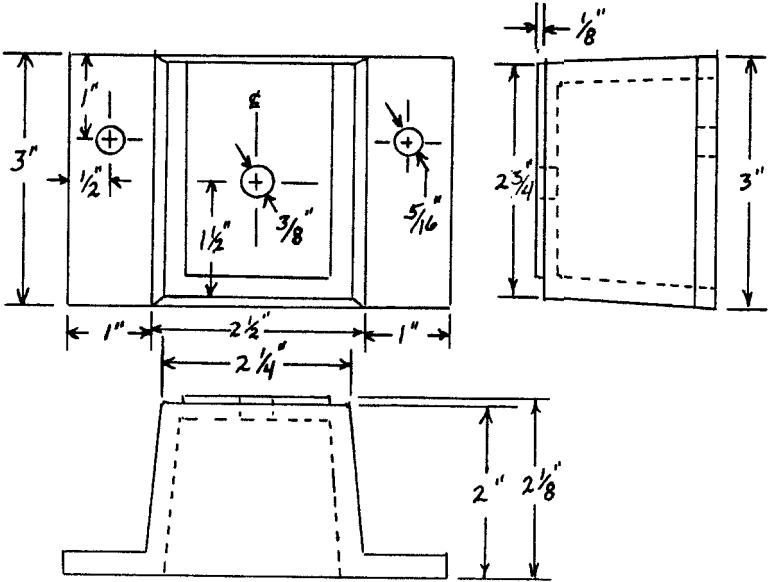

CHAPTER IV

THE CARRIAGE ASSEMBLY

Consisting of seven castings, plus an assortment of steel stock and hardware, the carriage may seem complex at first glance. It is really a simple mechanism.

The first item is the carriage casting, which supports the cross slide ways and the apron.

The tunnel on the top is for the cross slide feed screw. It is roughed in at $\frac{3}{8}$ " wide, and $\frac{7}{16}$ " deep, and widened at the top to $\frac{1}{2}$ " to provide ample draft.

The parting line is at the surface of the wear pads, so draft will be both above and below that line.

Two dimensions have been left out of the pattern drawing to avoid confusing lines: The depth of the box slide is $\frac{1}{4}$ ", and the depth of the raised portion between the wear pads is $\frac{1}{16}$ ".

THE CARRIAGE PATTERN

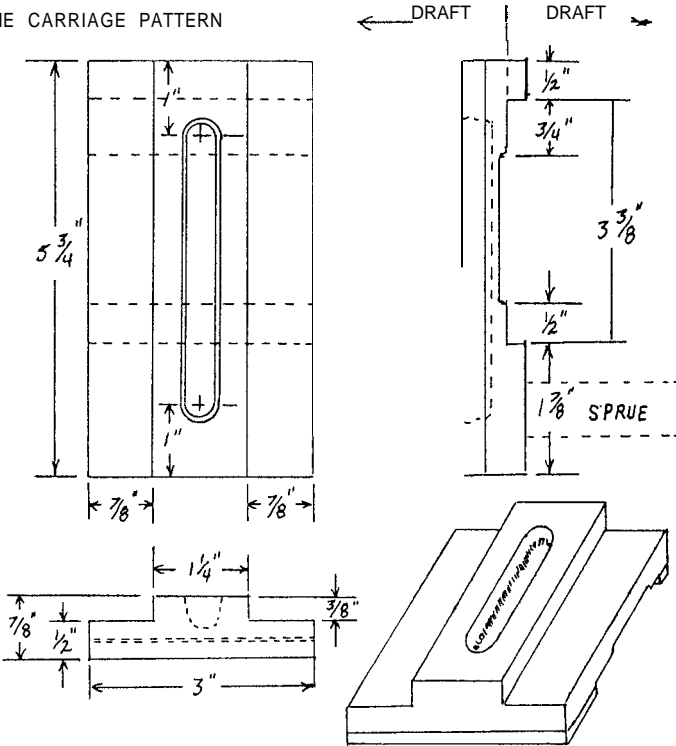

Notice that the back wear pad is $3/4$ ", and the front pad is $11/2$ ". Also, the box slide is made $3/8$ " over the size of the bed ways. There will be a $1/4$ " square gib in the back slide, and the casting will shrink something over $1/16$ ", to bring the casting to its proper size.

It will be easiest to make this pattern out of a piece of $5/8$ " stock for the portion above the parting line, and add the two $1/4$ " blocks below the parting line.

MOLDING THE CARRIAGE

This will be a false cope type mold, because of the green sand core which forms the tunnel, and the most convenient place for gating is at the bottom.

Prepare a false cope and press the base of the pattern in, up to the parting line. Tap it gently as you press it in, and make sure it doesn't rock in the cavity.

Dust with parting, and ram up the drag over the pattern. Rub in the bottom board, and roll over the mold.

When you lift the cope you will see the base of the pattern. There will be a ragged edge at each side, because the raised portion between the pads is below the parting plane. With a small trowel, smooth down the edge so that it slopes gently from the edge of the pattern to the parting level of the sand. This is called "coping down".

In coping down, you have changed the contour of the drag sand; the cope sand will no longer fit at that point. Dump out the cope and re-set it on the mold. Set the sprue pin in the center of the space indicated on the drawing. A 1" sprue will feed this mold.

Ram up the cope, open the mold and remove the pattern, clean up and close the mold, and you are ready to pour.

FINISHING THE CARRIAGE CASTING

Cut off the sprue, clean up the fins at the parting line, and file the sand texture from the top and bottom surface.

A piece of $1/4$ " X 3" cold rolled steel, about 6" long, will be a handy tool for the next operations.

The reason for the raised portion between the front and back, is to separate the bearing surface into pads. It reduces friction, provides clearance at the center of the ways; and makes the fitting job much easier because there is much less surface to scrape. To separate the horizontal pads from the vertical pads, cut a groove with a hack saw in each corner.

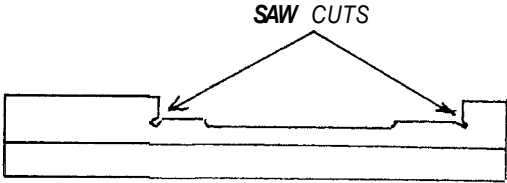

There are now four distinctly separate wear pads; two vertical, and two horizontal. In order that the carriage will slide smoothly and accurately on the ways, these pads must be carefully fit before the steel clamps are installed on the carriage. This is another hand scraping job.

First, file the sand texture from the surface of the pads. Here is where the safe edge lathe file comes in; you can file each pad separately, without cutting on the side. Don't try to perfect it, just prepare it for scraping.

Now, stain all four pads with the prussian blue. Make sure there are no nicks or burrs on the bed ways, wipe it clean, and slide the carriage along the ways to mark the high spots. Using a well honed wood chisel, carefully scrape the high spots. Repeat scraping and testing until you have as near full contact on all surfaces as you can manage. Don't be concerned with the depth of the box at this time. The front vertical pad, and the two horizontal pads are the important ones. The back vertical pad will not bear on the ways because the gib will be there.

When the pads are true and flat, you can prepare the carriage casting for the steel clamps, which will complete the box slide. They are 1/4" X 1" X 3" cold rolled steel.

The gib is a 3" length of 1/4" square key stock. It, together with the 6" piece of 1/4" X 3" steel, will serve as a gauge for fitting the clamps. If the pads have been carefully done, the gauge will rest on them without rocking.

With the casting clamped in the vise, and the gauge in the channel, file the bottom surface until it is even with the top surface of the gauge. You'll know when it is close because the file will begin to touch the gauge. Keep the surface flat and even as you work; don't let it get round on you.

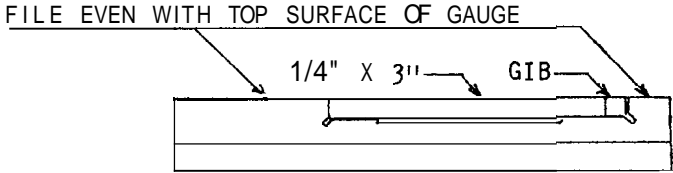

When the depth of the box slide is brought down to 1/4", remove the gauge and continue to file until you have removed an additional .003" or .004" from the bottom surface of the carriage casting.

Finish the bottom by hand scraping, using the ways or other flat surface as a test standard. Obviously, the box slide is less than 1/4"; the difference will be made up by adding shims, which will provide for adjustment when the pads wear down in use.

The clamps of 1/4" cold rolled steel can be prepared by marking, and center punching the hole locations. Note that there is a difference in hole locations. They are held in place by two 114"-20 flat head screws, which are countersunk so the heads will be even with the surface of the clamps.

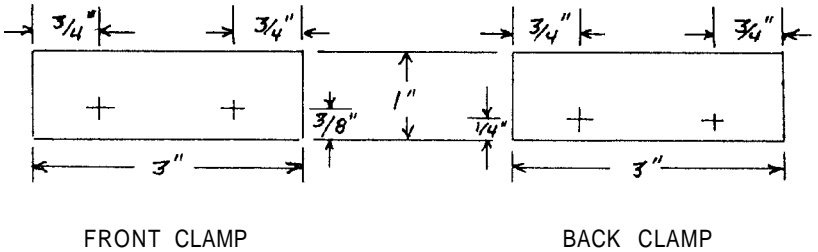

The fitting of the clamps to the carriage casting is done by adding or subtracting shims until you have a smooth sliding fit, with a minimum of play.

The shims for the front clamp will be $3/4$ " wide and 3" long. Those for the back clamp are $1/2$ " wide and 3" long. Cut five or six of each out of .001" brass shim stock.

Again using the $1/4$ " X 3" steel, and the gib, for a gauge, assemble the clamps to the casting with C-clamps or vise grip pliers. Add or remove shims until the gauge will fit with just a little drag. Then proceed to drill and tap the holes. Notice that the front clamp overhangs the ways by $1/4$ ".

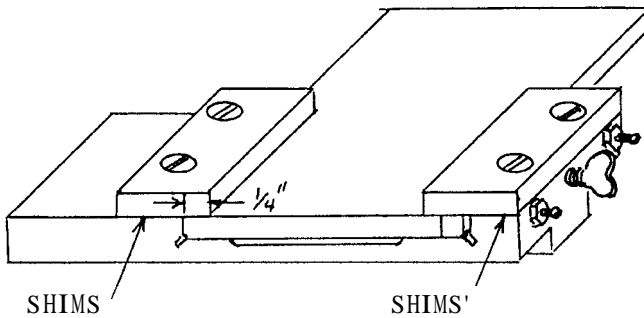

Two #10-24 X $3/4$ " gib screws are added, $1/2$ " from each end. The ends of the screws are pointed, and they enter a dimple in the gib, which is formed by the tap drill as it is drilled. This drilling must be done very carefully, because there is very little room to play with. It's best to complete the installation of one gib screw, and tighten it against the gib, before you drill the second hole. It is very easy to break a 10-24 tap, take your time.

The center screw is a $1/4$ "-20 thumb screw that is for locking the carriage at any point along the ways. It does not have a pointed end or a dimple in the gib. The gib screws require lock nuts, the clamp screw does not. Again, it is very close work to drill and tap the clamp screw hole.

For the final adjustment of the box clamps, the carriage is installed on the bed ways. With the gib loose, add or remove shims, until the carriage will slide freely long the entire length of the bed ways. It is better to allow just a little play, up and down, than it is to have the carriage bind at any place along the ways.

SCRAPING THE FRONT WAYS

The carriage must be fit to the bed ways before the cross slide ways are installed. Some hand scraping must be done to bring the front ways parallel to the back ways.

Sliding the carriage up and down the ways, gradually tighten the gib screws until you feel a little drag at any place. Stain the front way with the prussian blue, and proceed to scrape down the high spots. Repeat until the carriage fits uniformly along the bed ways.

When the fit is satisfactory, the final adjustment of the gib screws should leave the carriage free to slide all along the ways with finger pressure. Again, better to be a tiny bit loose, than to bind at any place.

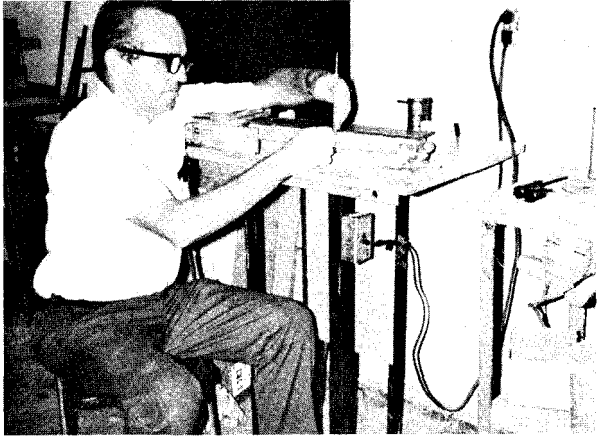

THE CROSS SLIDE WAYS

This is a slab of 1/4" X 2" X 7" cold rolled steel, fastened to the cross slide casting with three 1/4"-20 X 3/4" flat head screws.

Before the ways are installed, the top surface of the carriage must be filed and scraped flat and parallel to the bed ways. They must cross the bed ways at exactly 90 degrees, to ensure accurate face plate work.

TOP VIEW

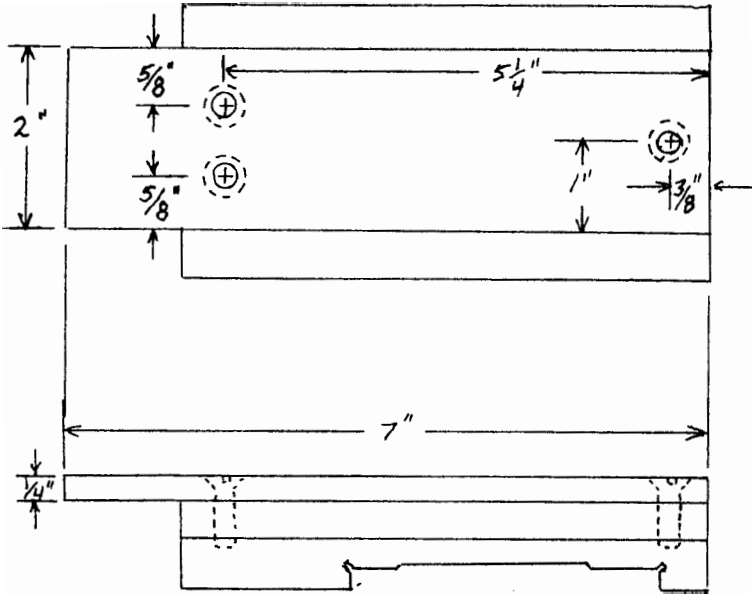

SIDE VIEW

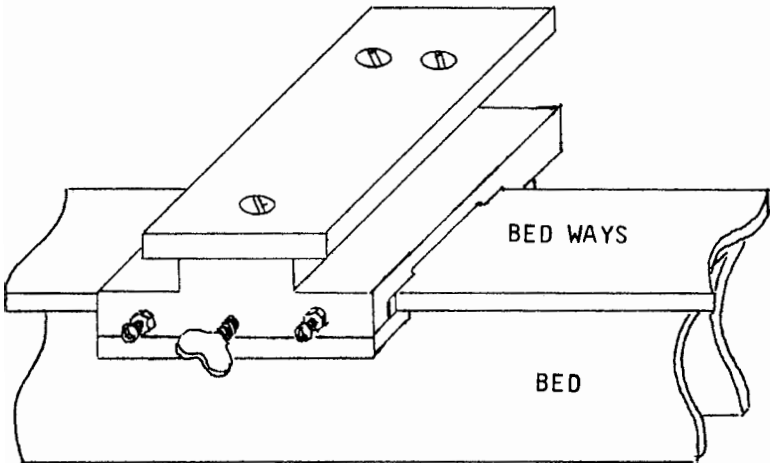

BACK VIEW

The steel ways are centered on the cross slide casting, to allow an equal amount to over-hang each side. The screw locations are critical because of the feed screw tunnel.

Install the ways with the back screw only, and adjust them to true square with the bed ways before you drill the holes for the two front screws. Clamp a length of angle iron to the bed ways, adjust it to as near true square as you can manage; and, with a good straight steel rule between the angle and the ways, adjust the ways to square. Then, clamp the front of the ways and install the two remaining screws.

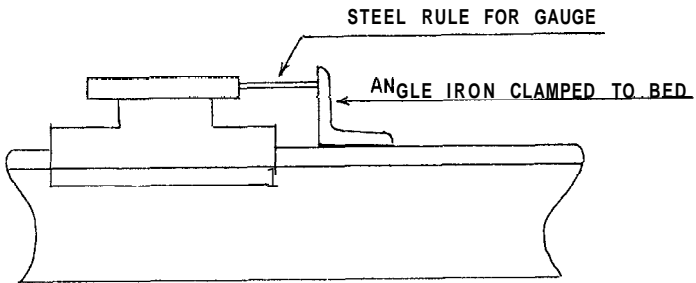

THE CROSS SLIDE CASTING

Made with a box slide, to ride the cross slide ways, it supports the compound swivel base, and it is fed across the ways with the cross slide feed screw.

Only general dimensions are shown on the drawing, to avoid confusing lines. As you study the pattern lay-out, add these details to your bench notes:

The clamp pads are both $\frac{1}{2}$ " wide, the space between them is $2\frac{1}{4}$ " wide. There will be an adjustment gib.

The wear pads are $\frac{1}{16}$ " thick; the pad on the gib side is $\frac{1}{2}$ " wide, the other is $\frac{1}{4}$ " wide.

The large concentric circles represent the raised pad for the compound swivel base. It is 3" O.D., $2\frac{1}{4}$ " I. D. and $\frac{1}{16}$ " thick. The discs and the wear pads can be made of two or three layers of cardboard, to total $\frac{1}{16}$ " thick. Glued together, and to the pattern, it is durable when it is sealed with lacquer or varnish.

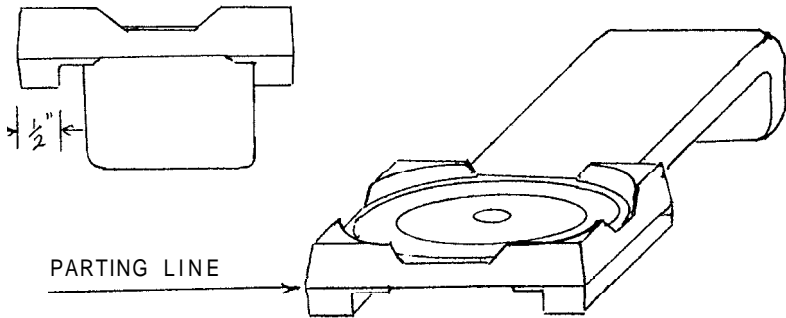
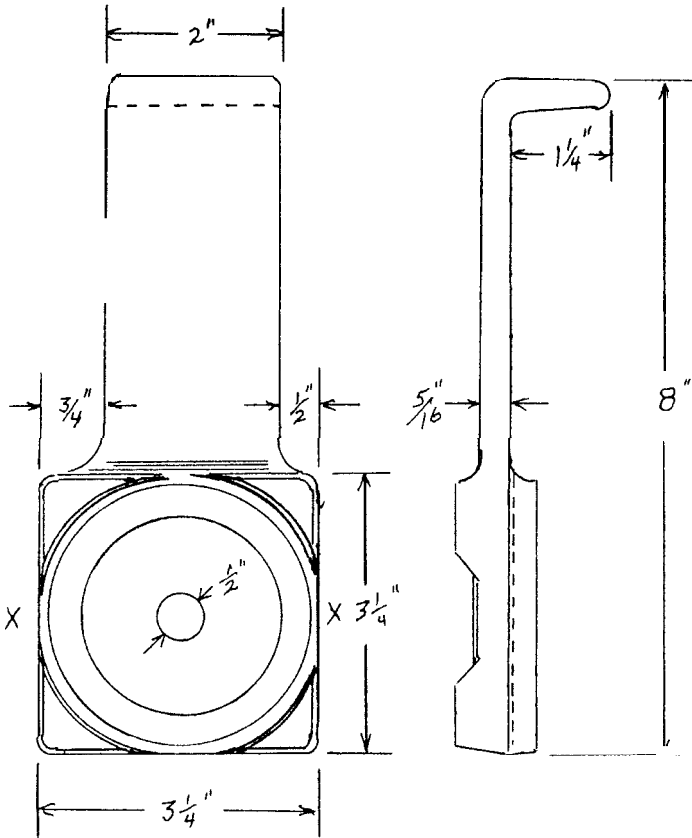

The 1/2" hole, the swivel base pad, and the top clamp pad circle are all centered in the 3-1/4" square portion of the pattern. Lay them out before you drill the 1/2" hole, so they will all be concentric.

The top clamp circle is 3-1/8" diameter at the base, and tapers to 3-1/4" at the top to provide draft. It is easiest to shape the inside draft before the pads are installed on the pattern with glue.

The shank portion of the pattern is off-set so it will be centered over the cross slide ways when the gib is installed.

The bearing support bracket for the feed screw, and the bottom clamp pads, are below the parting line, and so are the wear pads. The rest of the pattern is above the parting line. Remember that you have draft in two directions, above and below the parting line.

The easiest way to build this pattern, is to begin with 5/16" stock, and assemble the pieces as shown in the sketch. The 1/16" thickness of the wear pads and swivel base pads will leave a 1/4" depth for the ways and the swivel base. Shape the fillets with auto body putty, form the draft with sand paper, and round off the outside corners as you finish the pattern smooth. Fair off the edges of the pads, even though they are of thin section. Don't forget to taper the feed screw bearing support bracket.

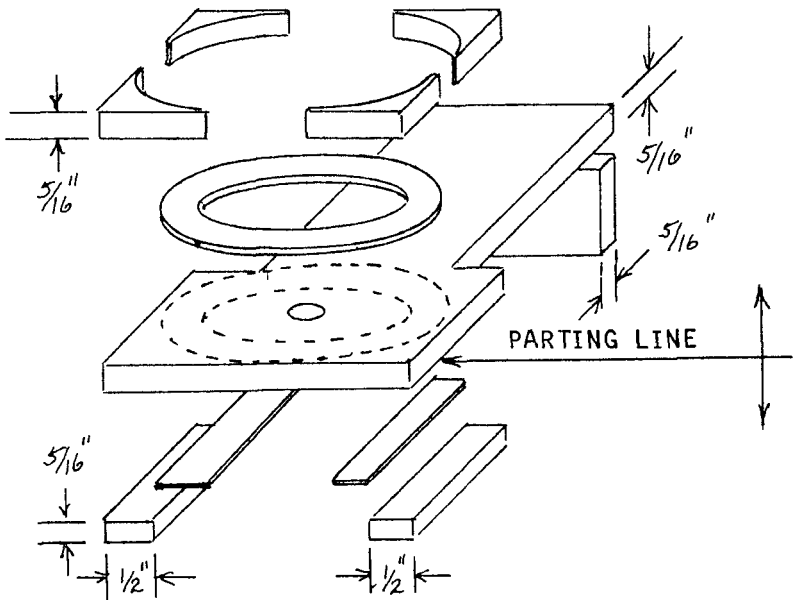

MOLDING THE CROSS SLIDE

Simple bedding will work well with this pattern, so prepare a blank drag, and press the pattern into the drag until the parting line rests on the sand. All of the pattern elements below the parting line will be bedded, including the wear pads; there will be no need to cope down. The drag will not have to be made over, as in the case of a false drag, and there is no rolling over.

Slick up the parting face all around the pattern, and set a 1" sprue pin 1-1/2" from each side of the pattern, as indicated by "X" on the pattern drawing.

Slip a 1/2" steel shaft in the center hole, long enough to leave a print in the sand, and extend above the cope by about 2". This is a steel core for the 1/2" hole.

Ram up the cope, remove the sprue pins, raise the steel shaft enough to clear the pattern, and clamp it with a spring type clothes pin, so it doesn't fall back in.

Push a 1/8" or 3/16" rod through the sand, to rap the pattern on the shank portion where it joins the heavy section. The hole can be left open for a vent.

Open the mold and remove the pattern. Lift straight up to avoid damaging the cavity.

Cut a gate from the cavity to each sprue print, clean up, and close the mold.

Remove the clothes pin and lower the steel shaft into its print in the bottom of the cavity. This provides the core for the 1/2" hole for the swivel base arbor.

Pour into either sprue, as fast as it will accept the metal, until it comes up in the riser.

FINISHING THE CROSS SLIDE CASTING

Cut off the gates and the small riser that formed in the rapping hole. Oil the steel shaft on both sides of the casting, and with the bottom of the casting supported close against the shaft, strike a hard blow on the long end of the shaft to loosen it. Turn it over, support it close against the shaft, and drive it out of the casting with a hammer and drift punch. Be careful not to mushroom the end of the shaft, which would distort the hole. The swivel base pad can be smoothed up with a wooden disc and emery cloth.

up with a wooden disc and emery cloth.

The finishing and fitting to the cross slide ways is the same as for the carriage to the bed ways.

It may require a small amount of scraping on the cross slide ways, to bring them parallel. If so, the cross slide will serve as the gauge.

The slide should fit the ways without play. The gib screws are adjusted for a very slight drag in the movement.

The clamps are each held with two 1/4"-24 flat head screws, and the three gib screws are 10-24 machine screws.

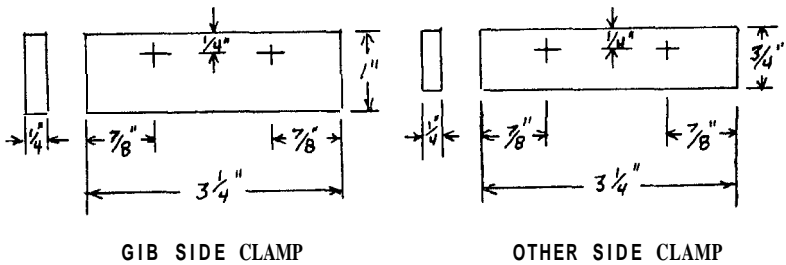

The clamps, of cold rolled steel, are installed in the same manner as the carriage clamps.

The gib is 1/8" X 1/4" X 3-1/4" steel or brass. It is held by dimples and pointed screws, like the carriage.

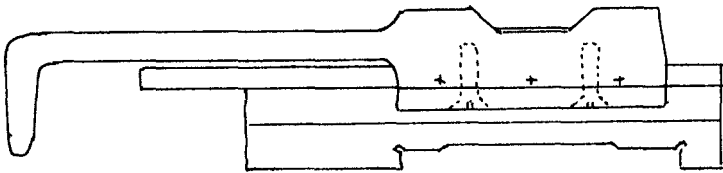

Gib screws are 1/2" from each end, and one in the center, same procedure as the carriage gib screws.

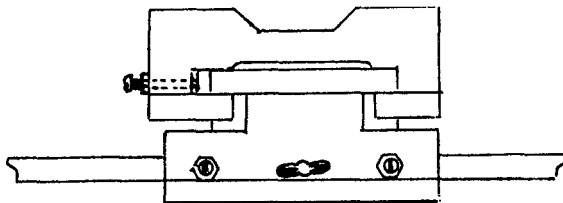

THE CROSS SLIDE FEED SCREW

A 114" steel rod, 8" long, and threaded for 4-314". Fitted with two set screw collars and a ball handle, it is threaded into the carriage casting to drive the cross slide.

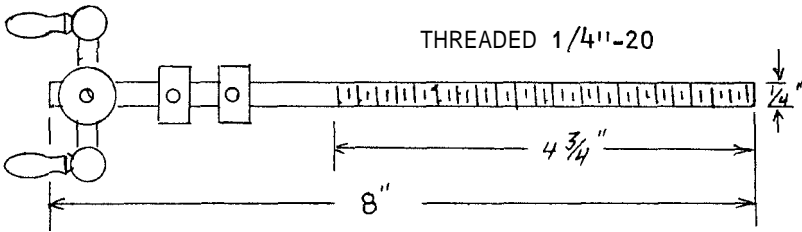

The tapped hole in the carriage casting, and the bearing hole in the cross slide must be carefully located so that the screw will run parallel to the tunnel in the carriage casting.

It is not difficult to locate the center for the tapped hole in the carriage. Mark it carefully, verify that it is in the center of the tunnel, but don't drill it at this time. Both castings will be drilled together, so it is only necessary to center punch for now.

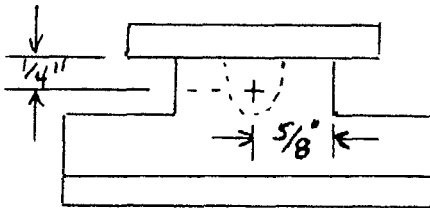

The more difficult part is to transfer this center to the bearing support bracket. If the centers are off by as little as 1/8", the screw may run into the sides of the tunnel before it completes its travel.

By laying a straight edge on the bottom of the cross slide clamp, you can transfer the horizontal center line to the bearing bracket. Do it on both sides of the casting, and scribe a sharp line across the face of the bracket, to establish the horizontal center line.

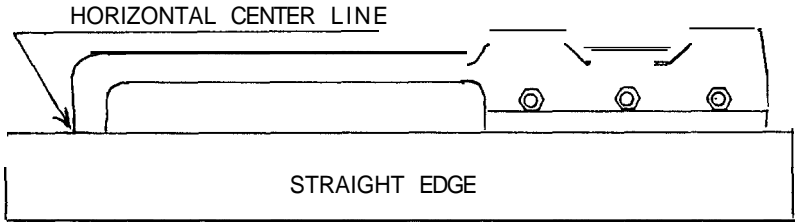

Measure the distance from the edge of the ways to the center. It will be near 1", but this is where the most serious error can occur, so do it carefully. If you rest a try square on the ways, with its beam protruding below, you can measure the distance accurately.

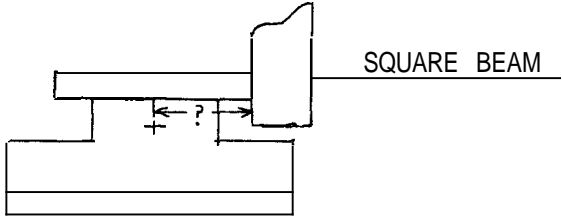

Install the cross slide with the gib adjusted for no play. Slide it all the way to the back of the ways, and with a straight edge to the side of the ways, transfer the dimension found in the last step.

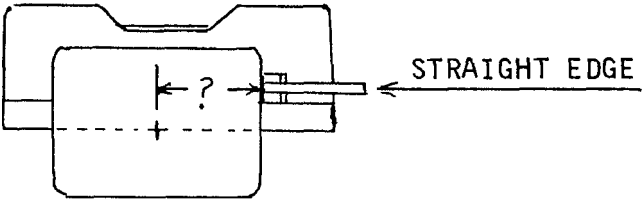

When you have located the vertical center on the bracket, punch it and drill a 1/8" pilot hole. If necessary, ream the hole a little, so that the point of the drill is in the center you punched in the carriage casting. Run it into the carriage casting as far as it will reach. It is not likely to reach all the way through the carriage casting, but you have established both bores concentrically.

Now, enlarge both holes to tap size for 1/4"-20 tap. By drilling through both members, the tap drill will follow the original center through the carriage casting, and into the tunnel.

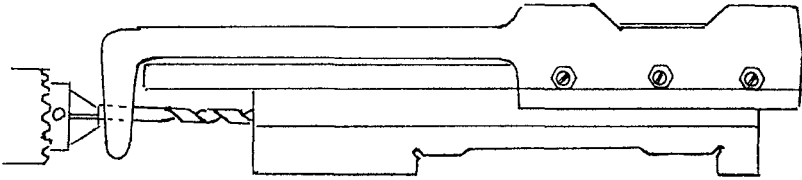

Enlarge the hole in the bearing bracket to 1/4", and use this hole to guide the tap, as you begin to cut the threads in the carriage casting. It is likely that the tap will not be long enough to reach all the way through, but once started straight, you can remove the cross slide and finish the job.

Run the feed screw all the way in, set a collar so that it rests against the end of the ways; install the cross slide, and set the other collar. Install a 2" ball handle to complete the cross feed drive.

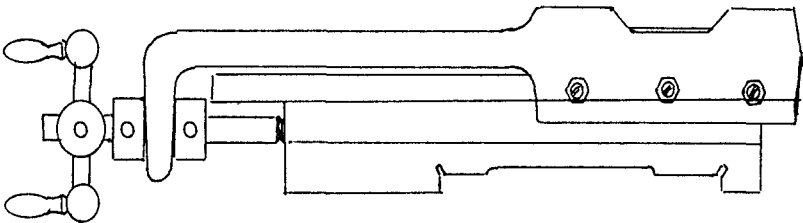

THE BALL HANDLES

Four feed handles are needed to complete the lathe. It is a simple job to cast a ball handle on a steel core, and it is ready for use when the core is driven out to leave the inside bore.

It is a difficult task to bore a hole through a metal ball; this simple method will serve you in a number of ways in your metal working projects. It works very well on small castings in aluminum or pot metal.

The pattern is made on a mandrel of the same size as the handle is to fit. A dowel makes a good mandrel. It leaves a print in the mold, into which you place the steel core. When the casting has cooled, the core is driven out to leave a finished hole. It remains only to cut off the sprue, clean up the casting, and install the set screw.

The same pattern can be used to produce handles with different bore sizes. By slipping bushings over the arbor, you can leave a print in the mold for a larger core.

Just three sizes may be used, or you can use the heavy single handled crank for the lead screw.

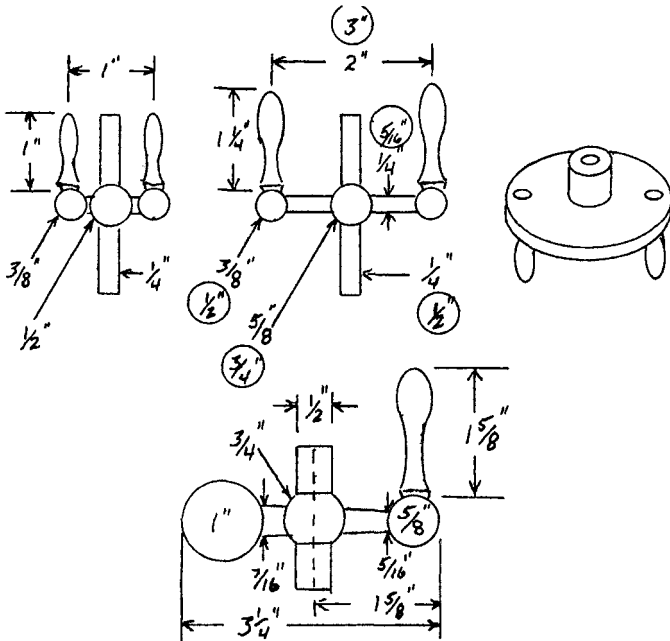

The smallest handle is for the compound feed screw. The intermediate size is for the cross feed and the tail ram. The circled dimensions on the intermediate handle are for use on the lead screw. The larger single handle crank is the type you see in the photographs of my lathe. It is a little more difficult to shape than the other type. It is not so appealing to the eye, but the disc type can be used in any of the applications.

I had the greatest difficulty in shaping these patterns until I discovered Macrame Beads. They are wooden beads that are sold in hobby stores. They come in a lot of sizes, both finished and unfinished. I bought the unfinished type, and a tube of that fast setting miracle glue that sticks anything to anything.

With these beads, pattern making is like playing with Tinker Toys. Since the holes are already bored, I just shaped a piece of dowel for the finger grips, another for the arms, and assembled with glue. I didn't trust the glue, so I drilled a 1/16" hole through each arm and into the center ball, and inserted a piece of wire with glue.

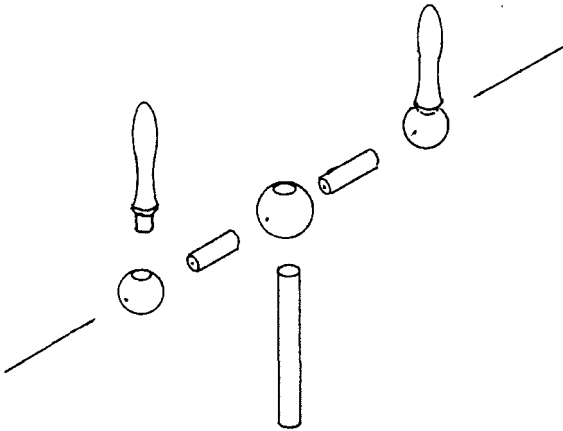

It is important to have the finger grips parallel to the mandrel center, or the handle will wobble when it turns. Sight along both grips, and align them with the mandrel as you assemble them. It's not difficult to drill the holes for the wire, if you rest the drill on the bench and feed the end of the ball to the spinning drill. The miracle glue dries so fast that I used five minute E-Poxy glue to bed the wire.

These patterns are ideal for simple bedding. Just prepare a blank drag, and press the pattern in to the parting line, which is the center of the balls. Set a 3/8" dowel on the center ball, for a sprue pin, and ram up the cope. Tap the pin lightly, and remove it before you open up the mold.

Remove the pattern, and lay the steel core in the print that was left by the mandrel. Since writing "Charcoal Foundry", I've learned that it is not necessary to preheat the steel core. Smoking the core over a candle flame makes it easier to drive out later.

Carefully push a small vent wire into the finger grip cavity, at its largest diameter, and right through the sand. It is not likely that you could hit the right place if you aimed for it through the sand in the usual manner. This is an important step, because there is not enough pressure from so small a weight of metal to force the gas out. You don't want a gas bubble in the handle.

These handles can be cast in aluminum or pot metal. Aluminum is a little easier to work with, but the pot metal is stronger.

When the casting has cooled, cut off the sprue and clean up the fins.

The end of the core should be ground to a bevel before you drive it out. Oil it, and support the ball close to the core, as you strike one end with a hammer to loosen it. Turn it over and drive the core out with a punch.

Drill and tap the center ball for a #10-24 set screw.

THE COMPOUND SWIVEL BASE

Similar in design and function to the carriage, but, it is made to swivel on the cross slide, providing means to make angular cuts. It supports the compound slide ways, and locks in any position by means of the clamps bolted to the top pads on the cross slide casting.

The pattern is a simple figure when viewed as a rectangle fastened to the top of a disc. Its parting line is where the disc and the rectangle join. Again, there is draft above and below the parting plane. The feed screw tunnel is shaped just as in the carriage casting. It has a raised pad on the base of the disc that matches the pad on the cross slide casting. It is cast on a 1/2" steel arbor that will not be driven out of the casting.

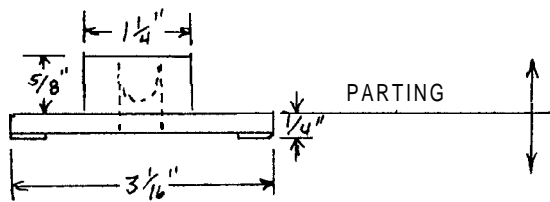
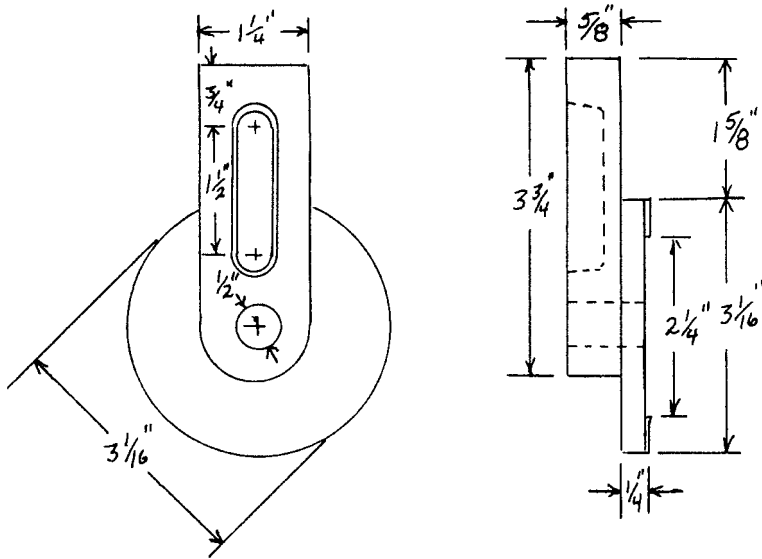

SCREW TUNNEL IS $\frac{1}{2}$ " DEEP AS IN CARRIAGE

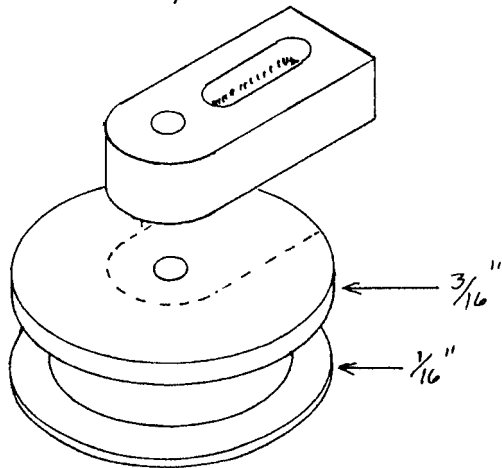

The total thickness of the base, including the 1/16" pad, is 114". The pad can be made up of cardboard, and glued to the base. The parts can be made separately, with a 1/2" hole bored in each. You can assemble them on a dowel rod, but the hole must be left open for molding. Wax the dowel so glue won't stick to it.

Fillet the inside corners and shape the draft in the screw tunnel. Sand a slight draft to the outside surfaces, round the outside corners, and seal the pattern.

A false cope mold is needed, so prepare the false cope and bed the disc portion of the pattern in it. Push a 1" length of 1/2" dowel into the hole, leaving its end even with the top surface of the pattern. Ram up the drag, being sure to fill the tunnel cavity firmly. Vent the drag and roll over the mold.

Remove the cope and dump it out. Pull the dowel out of the pattern, and replace it with a 112" steel rod, long enough to push through the pattern about 1/2", and extend above the cope sand.

Set a 1" sprue pin about midway on the rectangular portion of the pattern. Ram up the new cope, remove the sprue pin, raise the steel rod and clamp it, open the mold and remove the pattern.

Close the mold, lower the steel rod into its print, and pour as rapidly as the sprue will accept the metal.

When the casting has cooled, cut off the sprue, and cut the steel rod off even with the top of the casting.

The rod is cut to leave 112" at the bottom of the casting for the swivel arbor.

File and scrape the top of the casting to provide a solid mounting for the compound slide ways.

The slide ways are a slab of cold rolled steel, 1/4" X 2" X 3-314".

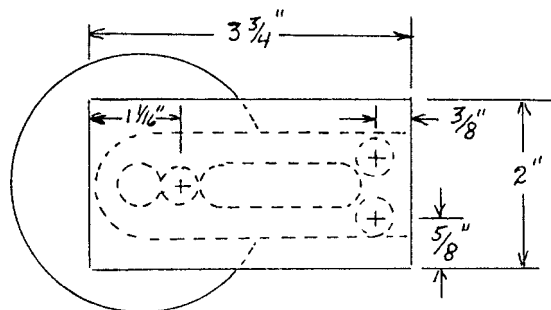

The ways are installed in the same manner as the carriage, with three 1/4"-20 flat head screws. There is no squaring up here, because the compound swivels, but the over-hang should be equal on both sides. Step drill the holes, as before, and install the center screw before you drill and tap the other two holes.

The compound swivel base is clamped to the cross slide by clips and cap screws that thread into the top pads. It will be as well to complete that step now.

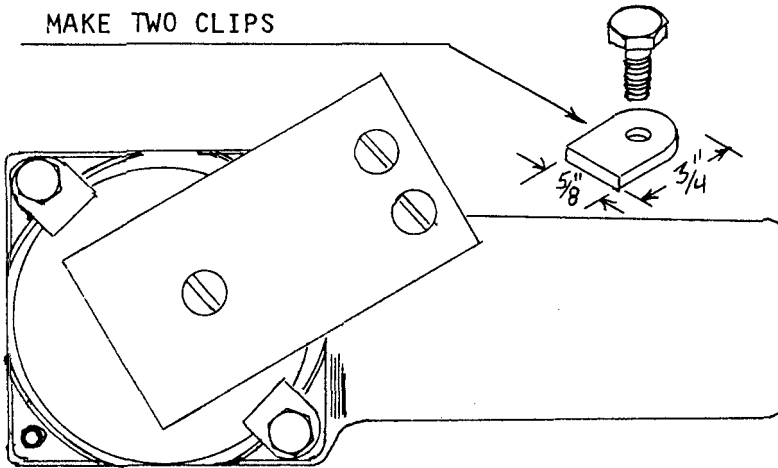

All four pads are drilled and tapped for 1/4"-20. but only two of them are used at any time. One hole will normally be covered by the swivel base, and the other should be plugged so it doesn't fill up with chips. By alternating the holes, it is possible to clamp the swivel at any angle in a full circle.

THE COMPOUND SLIDE

Very similar to the cross slide, except that the top surface is smooth, and it has two 3/8"-16 tapped holes for the tool post.

Building the pattern, molding, and casting are the same as for the cross slide.

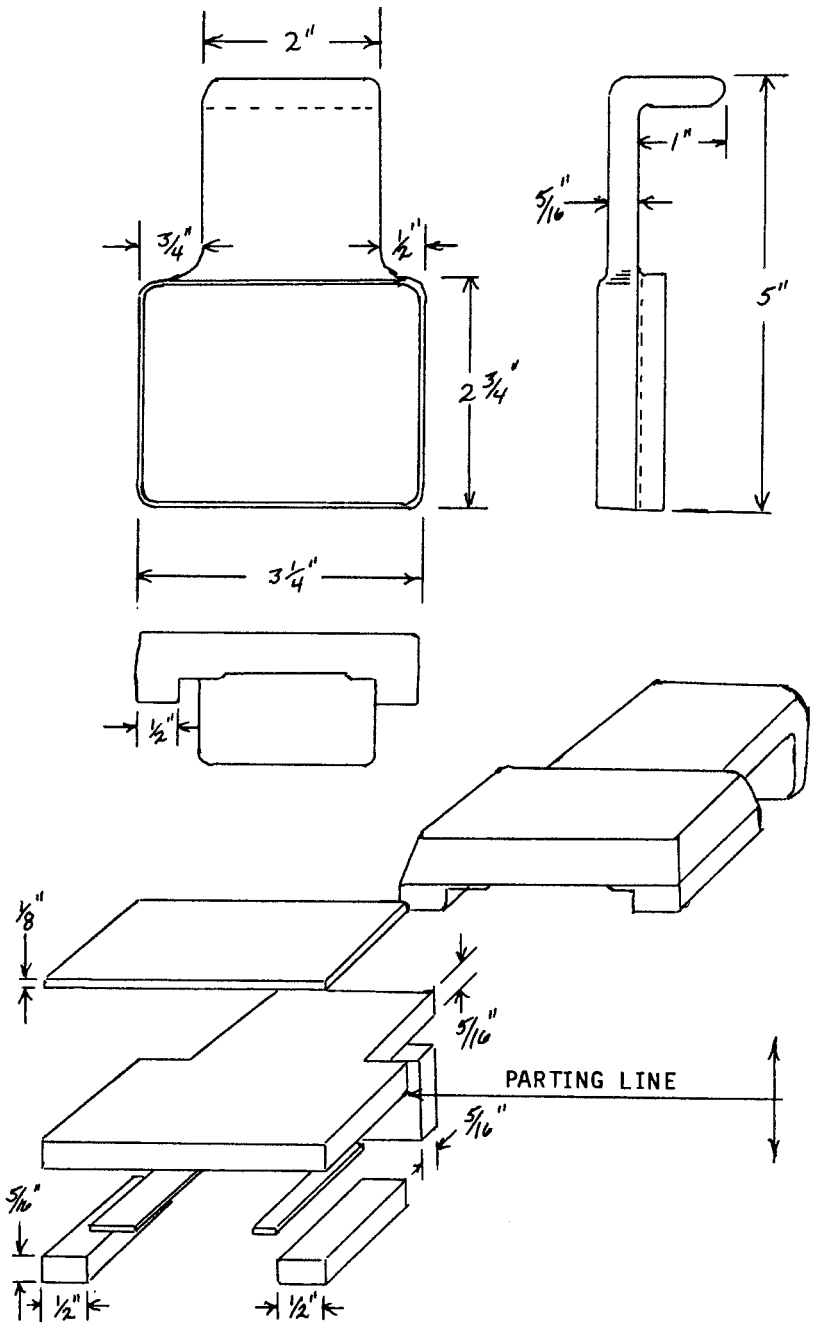

Finishing and fitting differs only in the top surface of the casting.

The pattern is made in the same manner as the cross slide. The wear pads are 1/16" thick, and they can be made of cardboard.

The molding and casting are the same as the cross slide, and so is the finishing and fitting.

The feed screw can be fitted with a 1" fluted knob, or a small ball handle. I used a 2" ball handle on mine; it won't make a full turn when it is positioned over the shank of the cross slide, but that is not often necessary.

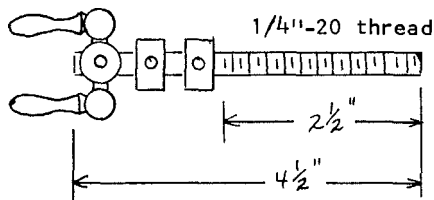
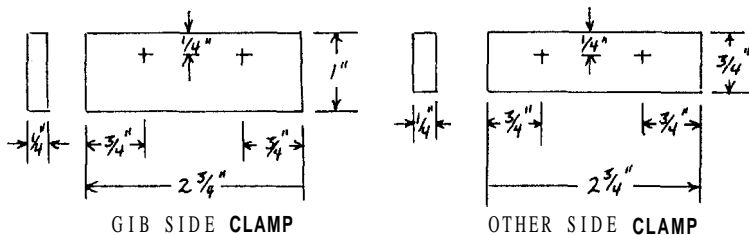

FEED SCREW

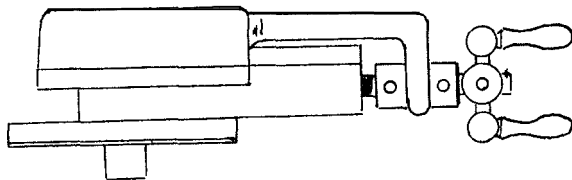

The clamps are installed with four 1/4"-20 flat head screws, the gib screws are #10-24.

The gib is 1/8" x 1 1/4" X 2-3/4" steel or brass. The screws are located 3/8" from each end, and one in the center.

THE TOOL POST

The axle stud for a lawn mower wheel is a steel shoulder bolt with a 1/2" shank and a 3/8"-16 thread. It is ideal stock for the tool post. They are available in most hardware stores at about \$1.00. Get two of them, the other one will be the axle for the reduction pulley in the lead screw drive mechanism.

Being made of mild steel, it is easy stock to work. Just cut off the head, drill a row of 1/4" holes in the shank, and finish to a 1/4" width with a file.

A 1/4"-20 hole is tapped in the top to accept the set screw.

The height of the tool can be adjusted with a stack of washers, or you can make the conventional concave washer with a rocker bar for the same purpose.

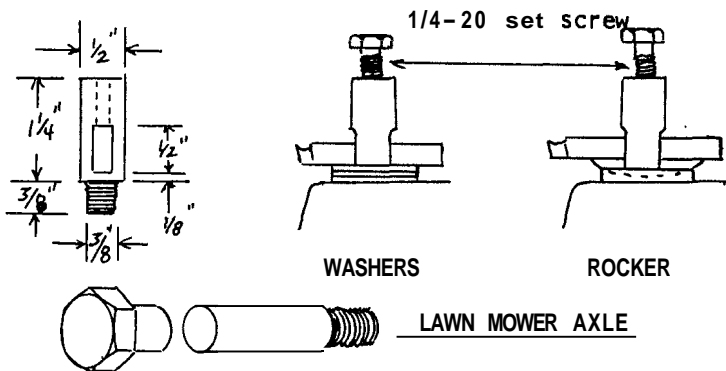

Two 3/8"-16 holes are tapped in the top of the compound slide for mounting the tool post on either side. The un-used hole is plugged to keep it clean. The customary "T" slot in the top of the compound is too difficult to form without a miller or shaper. You may elect to make the conventional type later on in your career.

Both holes are 5/8" from the front edge, and 5/8" from each side.

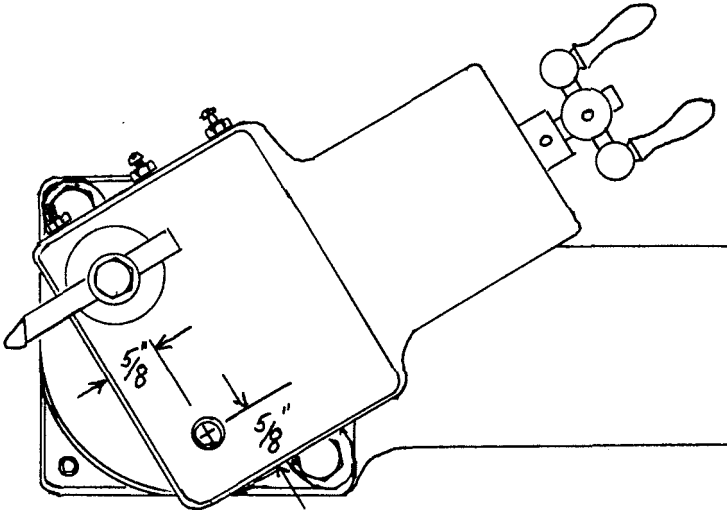

THE CARRIAGE APRON

The easiest casting in the project. It supports the split nut mechanism to drive the carriage along the ways.

A simple two part mold, and you can pour it with a 1" pop gate located in the center of the pattern.

The surfaces of the casting need only be reasonably smooth for good appearance, and the top surface must be filed to 90 degrees with the inside surface.

It is fastened to the carriage with two 1/4"-20 flat head screws. The inside surface must be parallel to the bed ways.

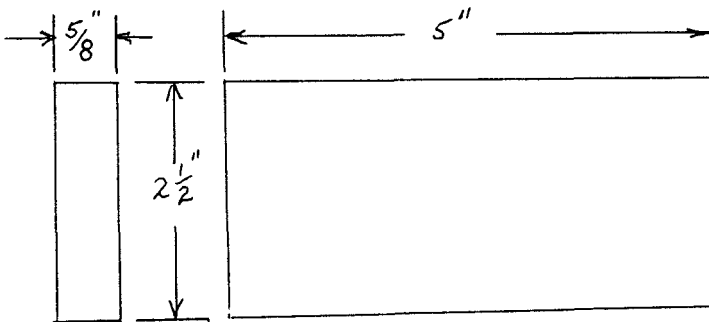

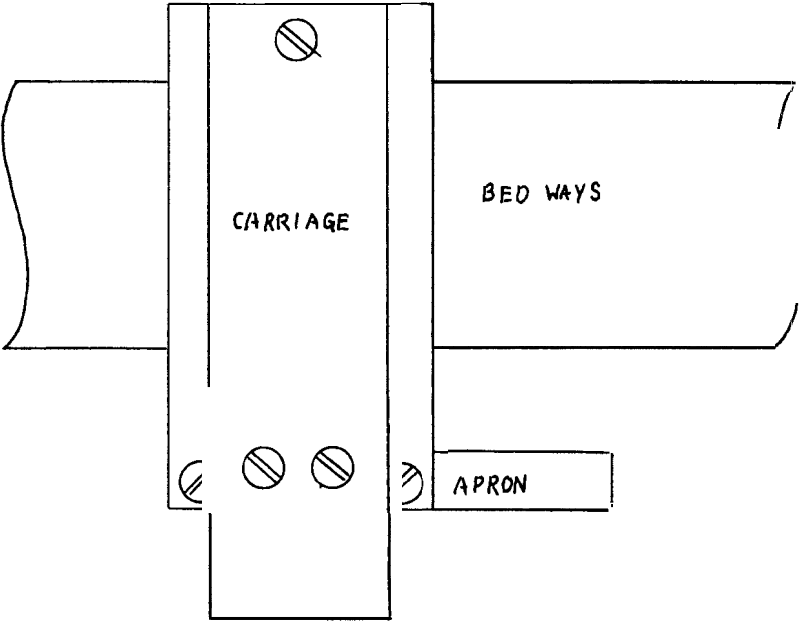
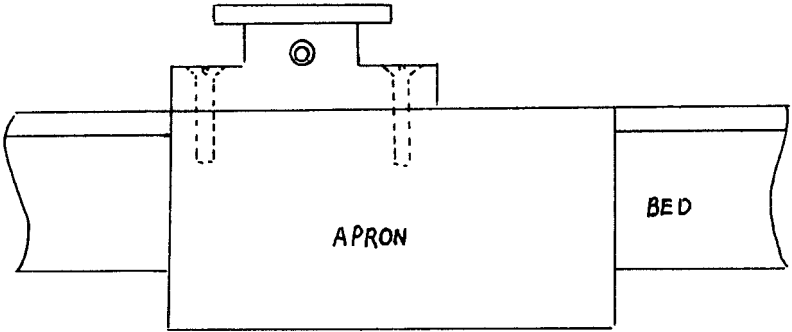

CHAPTER V

THE LEAD SCREW AND SPLIT NUT MECHANISM

There is no telling how long it must have taken the un-known Frenchman to prepare the first lead screw. Maybe he is un-known because by the time he had finished the job, he couldn't remember who he was.

We have an advantage for; all we need is a length of 318"-16 threaded rod and a couple of 114" black pipe nipples. Most of the work is already done for us.

The 1/4" black pipe nipples are conveniently very near to 112" in diameter. The inside bore is very near to tap size for 3/8"-16 threads. They will make serviceable bearing journals for the lead screw.

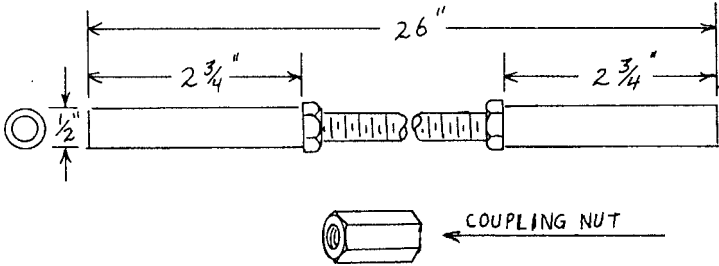

THE BEARING JOURNALS

Lacking a lathe to produce the journals, we'll have to improvise one. The drawing shows the lead screw as it is when completed. The 1/4" pipe nipples are very near to 9/16" in diameter, so we have to reduce them to 112". The coupling nut is used to drive the head stock when it is bored; for now, just thread it onto the screw, near the left end, and forget about it.

Cut the nipples to length with a hack saw, rather than a pipe cutter, so the inside bore won't be distorted. If you cut them off as near true square as possible, and use a standard nut to guide the tap, you can cut pretty accurate threads in one end of each nipple. Just clamp the nut and the nipple together in a vise, and run the tap through the nut and into the end of the nipple.

Assemble the lead screw as shown in the drawing, with the jamb nuts to lock the nipples to the threaded rod.

There are a number of ways that you can mount the assembly to reduce the diameter of the shaft. I improvised a pair of wooden bearings, and connected it to the shaft of an electric motor with a rubber hose coupling. I made the wooden bearings adjustable, so I could tighten up as work progressed.

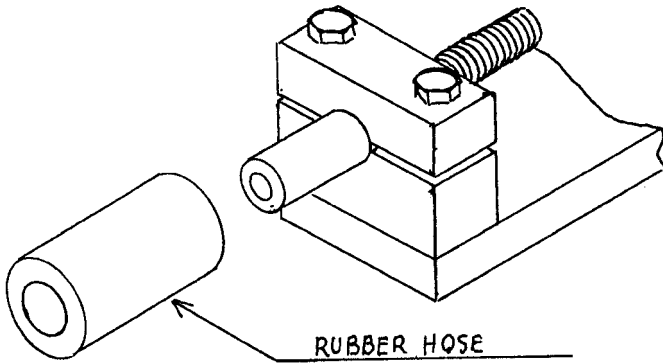

The 1/2" rubber hose will stretch to fit the nipple, and a pair of hose clamps will secure it to the nipple and the motor shaft. As the screw spins, you can apply the lathe file to the opposite end to reduce the diameter. A 1/2" set screw collar will serve as a gauge. File against the rotation of the shaft, and move the file as though the work were stationary, so you don't wear it out in one spot.

When the protruding part of the nipple is finished to size, reposition the wooden bearing to work the remaining portion. Repeat the operation on the other end, and the lead screw is finished.

These journals will be something less than perfect, but you can make better ones when your lathe is complete.

THE LEAD SCREW BEARINGS

These are simple castings; the procedure is unique in that they are cast on a steel mandrel to provide a finished inside bore.

The mounting holes are slots, so that the bearings can be adjusted vertically to bring the screw parallel to the bed ways.

The slots are cut after the casting is poured, so the patterns are a very simple matter.

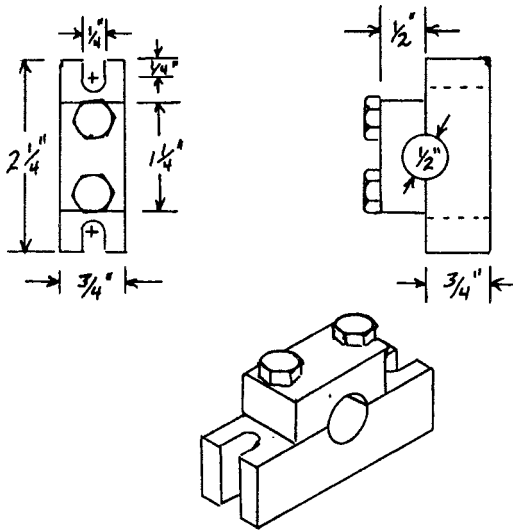

THE PATTERNS

Make two each of the bearing bases and caps, mount them on a 6" length of 1/2" dowel with glue, so that they can all be cast at the same time

The parting line is on the center of the bore, and it must be accurate, or the bore will be oval. Like all other patterns, there must be a slight amount of draft, and the outside corners are slightly rounded.

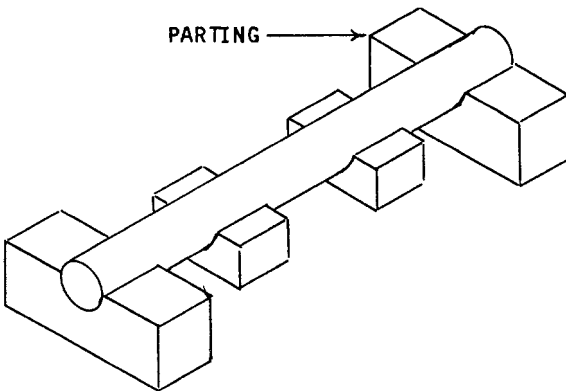

MOLDING THE BEARINGS

The pattern cavities will be in the cope, and the print for the steel core will be in the drag.

Prepare a blank drag, and bed the pattern arbor. Set a 1" sprue pin 1-1/2" to the side, and centered on the row.

Ram up the cope, remove the sprue pin, and rub in a bottom board. The pattern will stay in the cope when you open the mold, so you must lay it down to remove the pattern and cut the runner and gates in the cope sand.

Cut a pair of runners from the sprue, parallel to the row of patterns, and connect it to each cavity with a gate.

Set a 1 1/2" X 6" steel shaft in the drag print, close the mold and pour.

The illustration represents a top view of the casting, as it leaves the mold with runners and gates attached.

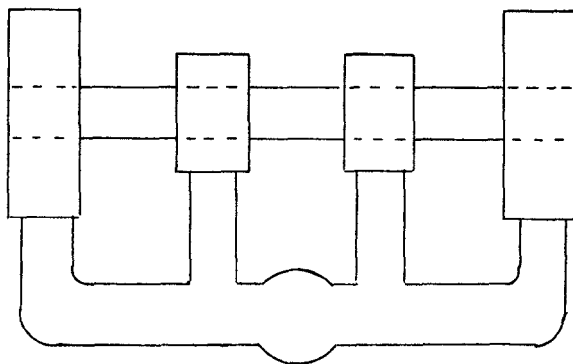

FINISHING THE CASTINGS

Simply knock the steel core off the casting, file the mating surfaces, cut off the gates, and drill the holes. The caps are held with 1/4"-20 cap screws. A base and cap are clamped together, with a 1/2" shaft in the bore, to assure alignment of the two halves when they are drilled and taped. The cap screw holes are centered 3/16"

from each end of the cap. There is only $1/16$ " clearance on each side of the bolt hole, so locate and drill these holes very carefully. This is a job where the step drilling technique proves its worth.

The lead screw moves very slowly, and the load is not heavy, so no bushings are needed.

This type of bearing is adjusted by filing the mating surfaces when the fit is too loose. When it is too tight, shims are used between the mating surfaces.

The same general method can be used to produce the pillow block bearings for the counter-shaft or the boring bar, but they need to be larger, and cast on a larger core, so that they will accept a bronze bushing for the higher speed and heavy load. I elected to buy mine from the hardware store for the sake of convenience.

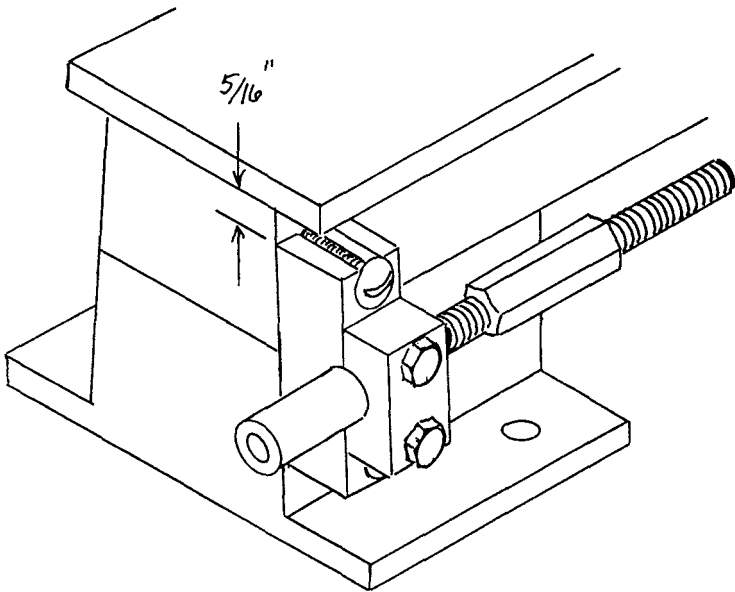

INSTALLING THE LEAD SCREW

The slots in the bearing bases are formed by drilling a 1/4" hole and cutting the end material away with a hacksaw.

The drawing shows the left end of the bed with the coupling nut for later use. There must be 5/16" clearance between the top of the bearing base and the bed ways, so the clamps for the head stock and tail stock will fit.

The right hand end is identical except for the coupling nut.

Clamp both ends in position, and mark the hole locations through the slots. Remove the assembly and drill and tap 1/4"-20 holes in the bed and mounting bases. This operation is best done with the lead screw in the bearings, so the bearings will be in line with each other. The slots permit a final adjustment by measuring from the bed ways to the lead screw journals, to bring the screw parallel to the ways. It may be necessary to use shims under one end of the bearing bases if the mounting bases and the bed do not meet evenly.

Install a set screw collar on each end, and install a 3" ball crank on the tail stock end. The screw should turn freely with a minimum of play. Better to be slightly loose than to bind.

THE SPLIT NUT MECHANISM

The design is very simple, being just two nut halves that are cast integrally on a rotating disc. Its pivot shaft passes through the apron, and it is operated by the lever on the outside of the apron. Carriage feed can be engaged or **dis-engaged** at will.

While the design principle is simple, it requires the most careful attention to detail to produce the casting. Taken one step at a time it is not so difficult a task, so don't let this little chore keep you from building your own metal lathe.

This type of part would ordinarily be a die casting, or an investment casting. Since both of these methods are outside the reach of the home shop, it was necessary to do the job in a green sand mold.

Like the compound swivel base, it is cast on a steel shaft which becomes its arbor. It is cast on a threaded steel core which forms the threads on the nut halves. It is produced entirely by hand, there are no machine operations involved.

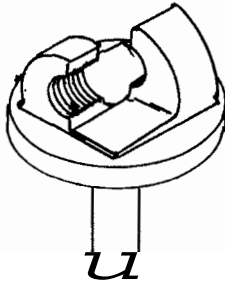

THE SPLIT NUT

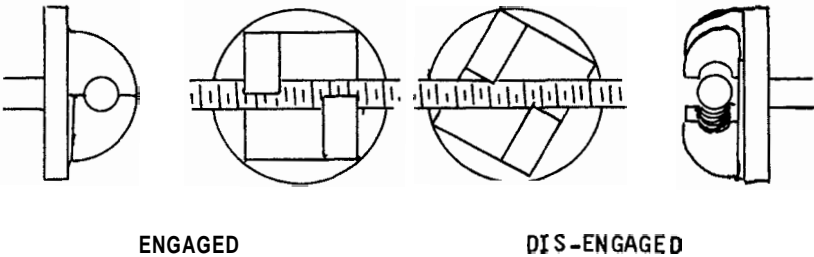

ENGAGED

DIS-ENGAGED

Without doubt, this is the most fascinating part of the entire project.

The drawings illustrate its anatomy and operating principle. A simple detent lever will lock it in either position.

While this part could be cast in aluminum, pot metal will make a far more durable casting.

I know of no other author writing on the use of steel cores in sand casting. I have done some extensive experimenting in this method. It works. The threads that are left by the steel core in this mold, are as sharp as if it were done with a tap. You can do it.

THE SPLIT NUT PATTERN

Begin with a wooden disc, 2" in diameter and 1/4" thick. Drill a 3/8" hole through its exact center. Make a 1-1/4" square block, 3/4" thick, and divide it into exact quarters. Drill a 3/8" hole through the exact center of the block. Coat a 3/8" dowel with paraffin, and use it for an arbor to align the block and the disc when you glue them together. Remove the dowel as soon as you have joined the parts, so it won't be bonded to them. The paraffin helps to prevent bonding. It is important to have the bore as near to center and as near to right angles as possible. You can check its trueness by rotating the dowel, and test the angle of the dowel at the base of the pattern with a try square.

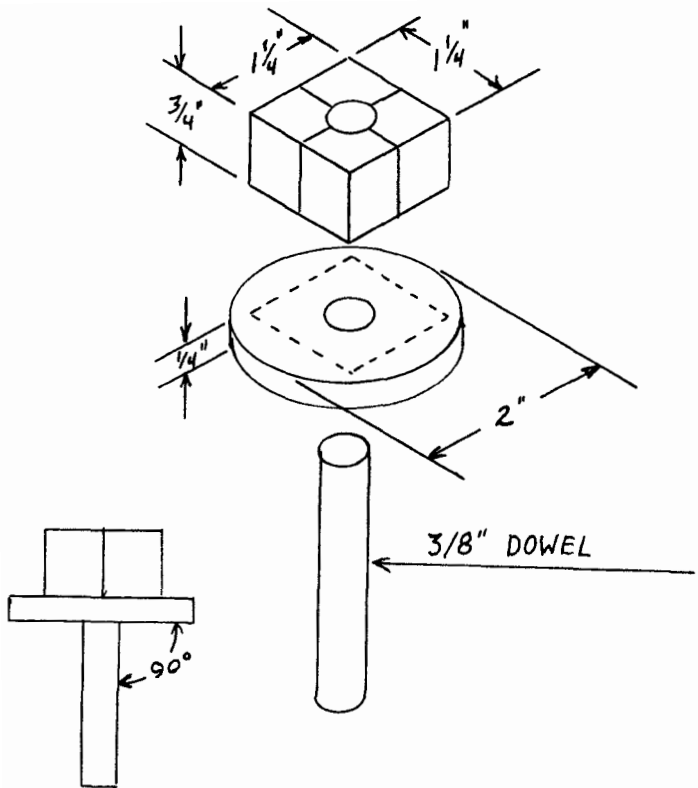

The lines which divide the block into quarters will be the centers for the thread bore and the channel that divides the nut halves.

Carefully drill a $\frac{3}{8}$ " hole through the side of the block, centered $\frac{1}{4}$ " above the disc.

Rotate the pattern $\frac{1}{4}$ turn and drill a $\frac{1}{2}$ " hole centered $\frac{3}{8}$ " above the disc.

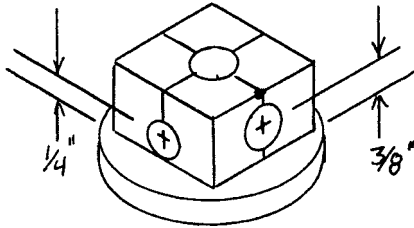

Extend lines from the $\frac{3}{8}$ " hole to the top surface of the pattern and cut out the center section with a coping saw. This forms the dividing channel between the nut halves.

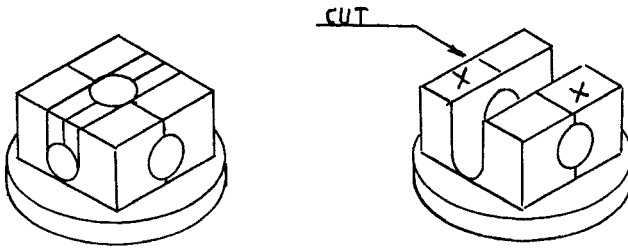

Cut away the portions marked "X" above to leave the two nut halves. Round the backs of the nut halves to the shape shown below.

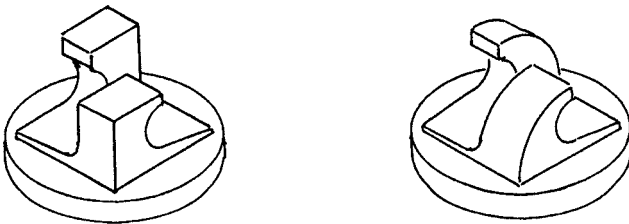

It remains to print the threads on the nut halves so that they will register with the threads of the lead screw. For this step, we need to install the pattern in the apron.

BORING THE SPLIT NUT PIVOT HOLE

This bore must be on the same center and at right angles to the lead screw

These measurements should be made near the tail stock end of the screw, to reduce the amount of error that may occur because of any bow in the screw. Rotate the screw, and if it is eccentric, position it so that the measurement will be in the center of its eccentricity.

With a small try square, scribe a line on both ends of the apron to represent the top and bottom diameter of the lead screw.

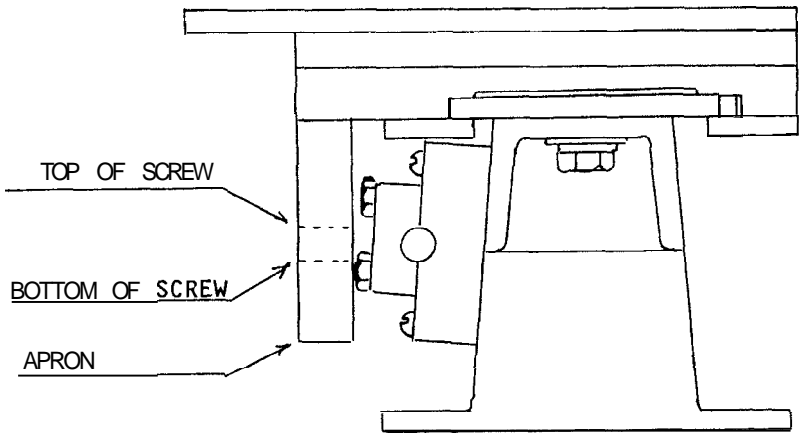

Locate the center of these two marks and extend the center line across the face of the apron. Center punch and drill a $3/8$ " hole, $1-1/8$ " from the tail stock end of the apron. Step drill this hole, and do your very best to drill it at right angles to the apron face. There is room for slight error, for the split nut arbor will fit this hole loosely, but hold the error to a minimum.

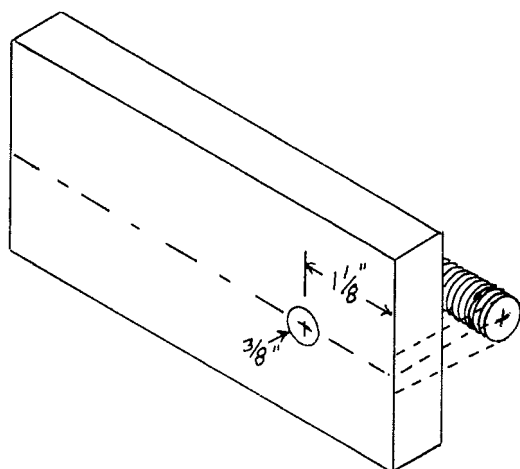

PRINTING THE THREADS ON THE PATTERN

The handiest material I've found for pattern work, is plastic auto body putty. A polyester resin, using a catalyst to harden it; it sets up quickly, but remains rubber like for some time after the initial set. This is what to use to transfer the thread pattern from the lead screw to the pattern.

The 1/2" diameter of the split nut halves leaves room for enough body putty to receive the print of the threads. Spraying the screw with silicone lubricant will prevent a bond between the putty and the screw. It's important not to get any of the silicone on the pattern.

This operation is only to register the split nut with the lead screw; it is not necessary to have a fully formed thread. By taking this print while the split nut is on the apron, you are assured that it will engage the screw when it is installed permanently.

Hold the split nut in position on the inside of the apron, and slip a dowel through the bore and into the pattern. Mix up a small amount of body putty and apply a dab of it to each nut half with a stick. Don't fill the half holes up, or it will ooze around the screw and you'll have difficulty releasing the pattern.

Rotate the pattern so that it will engage the screw. Stop rotating when the center of the nut bore is parallel to the center of the screw.

Let it rest in position until the putty has set to a rubber like consistency. You can check the left over putty from time to time to determine when it begins to set up. It takes from five to fifteen minutes, depending on the temperature. It sets faster if it is warm.

VIEW FROM BACK OF APRON

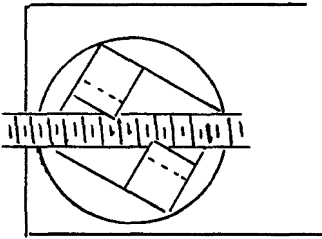

APPLY PUTTY

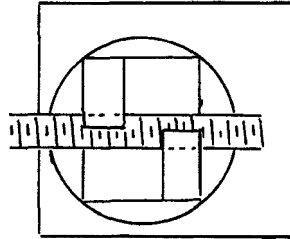

ROTATE PATTERN

INSTALL THE CORE PRINT

When the putty has set it will have the form of the lead screw threads. To reproduce female threads in the casting, we use a male threaded print in the mold cavity. A 1-1/4" length of 318"-16 threaded rod will form the print.

Cut the threaded rod to length, and install it in the pattern so that its threads register with the print taken from the lead screw. Mix up some more putty, and use it to form fillets, locking the threaded core to the pattern.

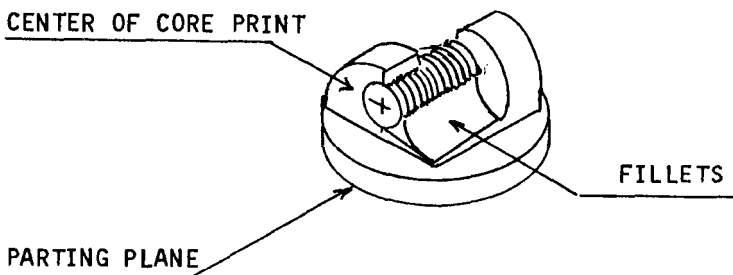

Form the fillets on both sides of the core, so that the screw is covered up to its center line, leaving no under-cut to lock the pattern in the sand. All of the core above the fillet line should have clean threads to leave a sharp print in the mold cavity. Be careful not to fill the 3/8" center hole with putty.

Add slight fillets where the nut halves meet the disc, slightly round the outside corners, sand all smooth, and seal with lacquer or varnish.

MOLDING THE SPLIT NUT CASTING

Lay the base of the pattern on the molding board; ram up and vent the drag, rub in the bottom board, and roll over.

Slip a 3/8" steel rod in the pivot hole in the pattern, long enough to extend above the cope.

Set a 1/2" or 3/4" sprue pin about 1-1/2" away from the pattern, so that a gate can be cut to one of the nut halves.

Ram up and vent the cope, remove the sprue pin, and raise the steel rod about 3/4". Clamp the rod with a spring type clothes pin, so it won't fall back in, and open the mold.

Slip a 3/8" dowel in the arbor hole, and use it to rap and remove the pattern. Cut the gate and clean up the cavity.

The pattern will have left a threaded print in the bottom of the cavity. Cut another length of 3/8"-16 threaded rod 1-1/4" long, smoke it over a candle flame, and carefully, with a tweezers or a needle nosed pliers, set the core in its print. You can judge the starting point of the threads in the core print by examining the threads on the pattern. Insert the core in the mold in the same relative position.

When the mold is closed up, remove the clothes pin and let the rod slip into the mold to rest on the threaded core. This will prevent the core from floating when the molten metal is poured in.

POURING THE MOLD

Nothing unusual in the pouring, except that we use pot metal for this casting. It can be done in aluminum, but pot metal will be much tougher and longer wearing.

FINISHING THE CASTING

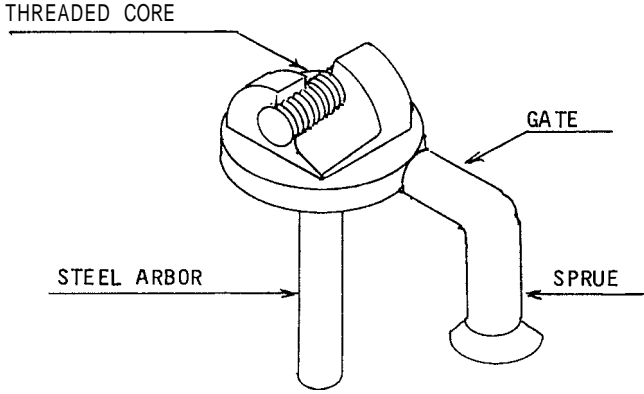

When the casting is shaken out, it remains to cut off the sprue, shorten the arbor to 1-1/2", and remove the threaded core.

The core is removed in pieces, beginning with the center section. Cut through the core to about 1/16" below the threads. Knock out the center section, and chisel and file the fillets away until the dividing channel is about 1/16" below the threads.

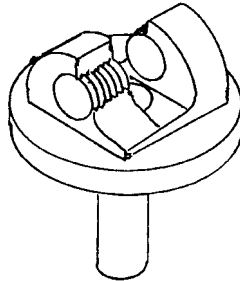

The remaining portions of the fillets are cut away with a chisel and file, and the end pieces of the core can be pulled out of the casting.

The final step is to clean up the threads with a 3/8"-16 tap. Do all of this work carefully, to leave a full half section of threads in each nut half.

THE SPLIT NUT LEVER

A simple pattern and casting, poured with a $\frac{3}{8}$ " steel core, in the same manner as the ball handles. It is finished by driving out the core and tapping the handle for a # 10-24 set screw to lock it to the split nut arbor.

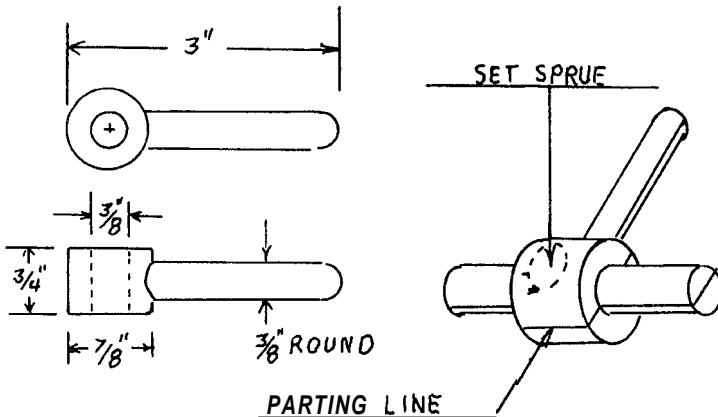

THE SPLIT NUT DETENT

A simple lever and spring that holds the split nut in either the engaged or dis-engaged position.

It will be easiest to install the lever and spring, and re-install the apron to mark the positions for the detent notches in the split nut casting.

VIEW AT REAR OF APRON WITH SPLIT NUT ENGAGED

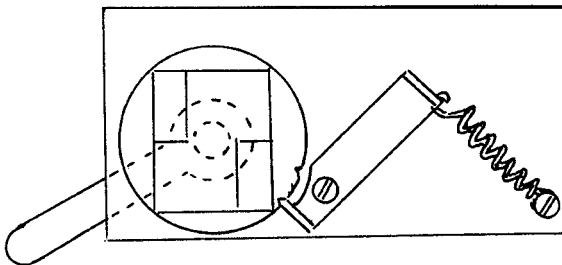

The detent lever is cold forged from a strip of $1/8$ " steel. The end of the pawl is rounded so it will move as smoothly as possible as it enters and leaves the detent notches in the split nut casting.

It is pivoted on a #10-24 machine screw, tapped into the apron, and the spring is anchored to the apron in the same manner.

I'm sorry that I can't give a specification for the spring. I picked mine out of my junk box. It must be small enough to clear the lead screw. The lever gives an advantage of three to one, so it does not have to be such a stiff spring. A little experimenting will find the right tension.

It helps to smooth the action if the edges of the detent notches are rounded off a little. I had to make two or three trial assemblies before I got the notches filed to the right shape and in the right position.

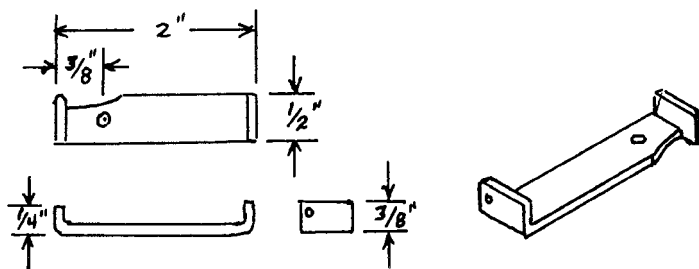

In the final assembly, the handle should be near horizontal when the nut is dis-engaged, and inclined down about **20** degrees when the nut is engaged.

This completes the manual drive for the carriage. By engaging the split nut and operating the crank on the end of the lead screw, you can drive the carriage up and down the ways.

The power drive train will be added when the head stock is installed.

It remains now to add the head stock and tail stock, and the lathe will be complete, but there will be some interesting operations that you can perform before we reach that point.

When the counter shaft is built, we'll actually use the lathe to machine the remainder of its parts.

CHAPTER VI

THE COUNTER SHAFT

Because it is needed in the boring operations, the counter shaft is the next logical order of construction.

The head stock is designed to use a four step pulley with steps of 5", 4 " 3", and 2". A 5/8" bore is the largest bore that is in common stock at the hardware store, and it will serve for the head stock spindle and the boring bar.

The counter shaft uses the same size steps, but the bore can be 1/2" or 5/8", depending on the size of shaft and bearing you choose.

A 6" or 8" out board pulley with a 1-1/2" motor pulley completes the reduction train.

With a 1-1/2" motor pulley and a 6" outboard pulley, the reduction ratio is 4 : 1. Using a 1725 RPM motor, the counter shaft will turn at 431 RPM. Using the 2 : 5 ratio of the step pulleys, the lowest spindle speed will be 172 RPM. The 3 : 4 step gives 323 RPM, the 4 : 3 step gives 575 RPM and, the 5 : 2 step gives a top speed of 1075 RPM.

Using an 8" outboard pulley gives a reduction of 5.33 : 1, and a counter shaft speed of 323 RPM. The advantage is, that you get a low spindle speed of 130 RPM; but, the efficiency of the drive is low at such speeds, and belt slipping problems seem to out-weigh the advantage. I use a 6" pulley on my counter shaft.

Back gearing is the only way to operate at low speed and high torque. Book six in this series will describe methods for producing a set of back gears for your lathe.

Any split phase motor of 1/4 HP or more will do the job. The motor base size will determine the width of the frame rails, so the motor should be on hand when you begin to build the counter shaft.

Being of simple design, little needs to be said about the construction of the frame assembly. Of course you can use different sized angle and strap iron; the sizes in the plan were what I had in the junk pile.

Welding would be the fastest way to join the members, but if you don't have a welder, use iron rivets instead of bolts and nuts. They are easy to cut with a hack saw, the ends peen easily, they are cheaper than bolts, and they do not work loose.

The mechanics of the assembly are simple. Notice the dotted center line from the release link pivot to the release lever pivot. When the release lever is drawn forward, the crank will pull the lower link pivot over the center line; unlocking the linkage and pulling the upright forward. When the handle is pushed back, the end of the crank will be against the link pivot bracket; stopping the motion and locking the action in the over center position.

A single forward motion releases belt tension for a speed change. Belt tension in the first stage of reduction is adjusted with the elongated holes in the motor base. The slots in the base rails are to provide a means to adjust the tension of the second stage belt.

To determine the right size belt, just run a flexible tape measure over the outside of both pulleys as though it were a belt. This gives you the length of the belt. Use an "A" belt which is 1/2" wide. Mine uses a 27" belt on the first stage, and a 28" belt on the second stage. It may differ because of different motor base dimensions.

The design is adaptable to most fractional horse power motors, but the spacing of the motor mounting bolts will be different. These dimensions are for a NEMA 48 frame; 2-3/4" between the slot centers, and 4-1/4" vertically. Check your mounting hole dimensions before you begin

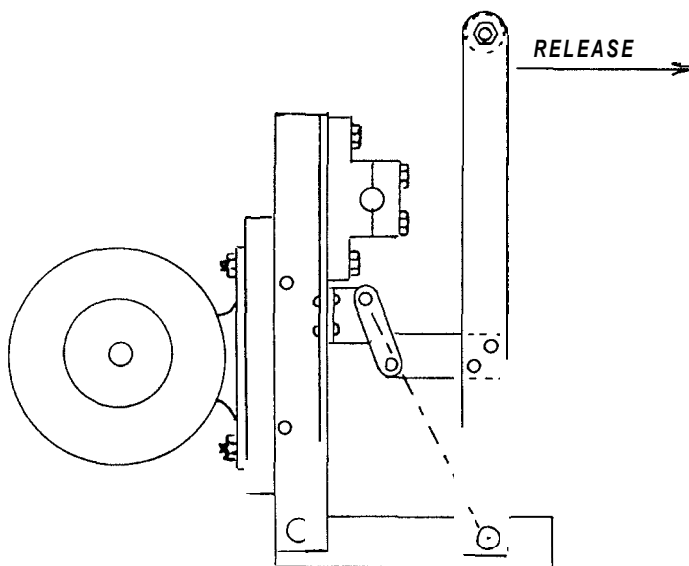

It will probably be best to build the motor mount to fit your motor, since you will need to know the dimensions to make the spreaders.

The motor mounting rails are two pieces of $1\frac{1}{4}$ " x 118 " angle iron $6\text{--}112$ " long. They are drilled and tapped for $\frac{1}{4}$ "-20 threads on the spacing that corresponds to the vertical spacing of the motor slots.

The motor rail spreaders are 1 " x $\frac{1}{8}$ " steel strap, cut 1 " longer than the space between the slot centers on the motor base. They are drilled $\frac{1}{4}$ " on centers 112 " from each end of the spreaders.

By bolting the spreaders to the rails, and letting the bolts extend through the rails about $\frac{1}{2}$ ", you will have studs for mounting the motor.

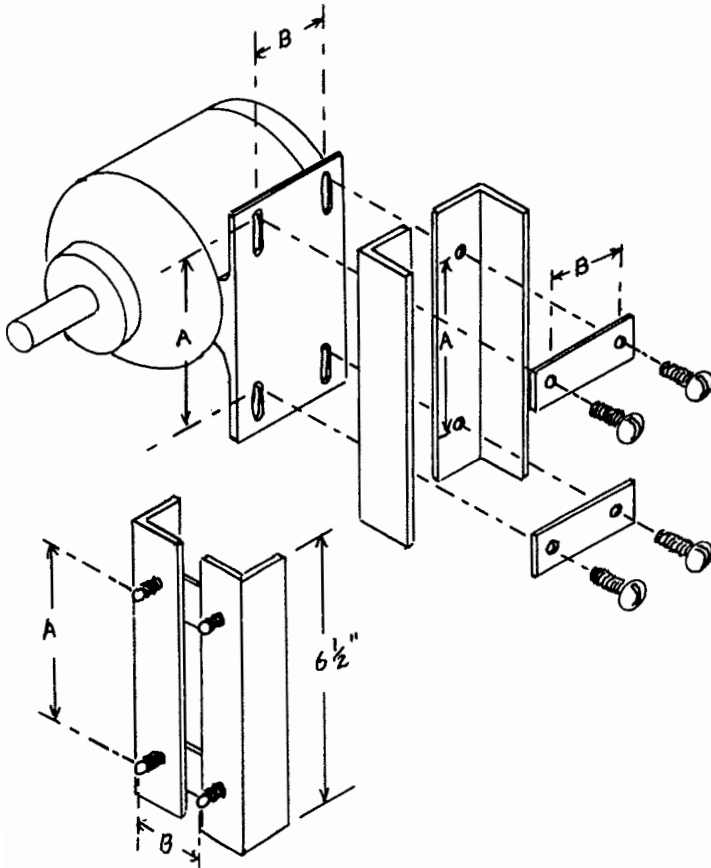

It will be easier to build the unit in two parts, as shown in the exploded view on page 74.

The base spreader is of the same material and dimension as the motor rail spreaders. If you use riveted construction, the holes in the base rails are counter-sunk so the rivet can be set even with the bottom surface. These spreaders are the last order of construction in the frame assembly.

To clarify the exploded drawing, the parts are named as follows;

1. Motor rail, 1-1/4" x 1/8" angle, 6-1/2" long.
2. Motor rail spreader, 1" x 1/8" strap, 3-3/4" long,
3. Base rail spreader, 1" x 1/8" strap, 3-3/4" long.
4. Upright rail , 1-114" x 118" angle, 10" long.
5. Base rail, 1-1/4" x 118" angle, 6-1/2" long.
6. Release crank, 1" x 1/8" strap, 3" long.
7. Release lever, 1" x 1/8" strap, 13" long.
8. Release link pivot, 1-1/4" x 1/8" angle, 1-1/4" long.
9. Release link, 1/2" x 1/8" strap, 2" long.
10. Release handle, 1" O.D. pipe, tube, or dowel, 3-3/4" long.
11. 6" outboard pulley.
12. Pillow block bearings.
13. 5", 4", 3", 2" step pulley.
14. Set screw collar.

Having determined the proper bolt spacing for the motor mounting bolts, and making a trial assembly, set them aside for now, and make the right and left hand sections.

The pivots for the upright and release levers should be 114" rivets. The link pivots and all others are 3/16".

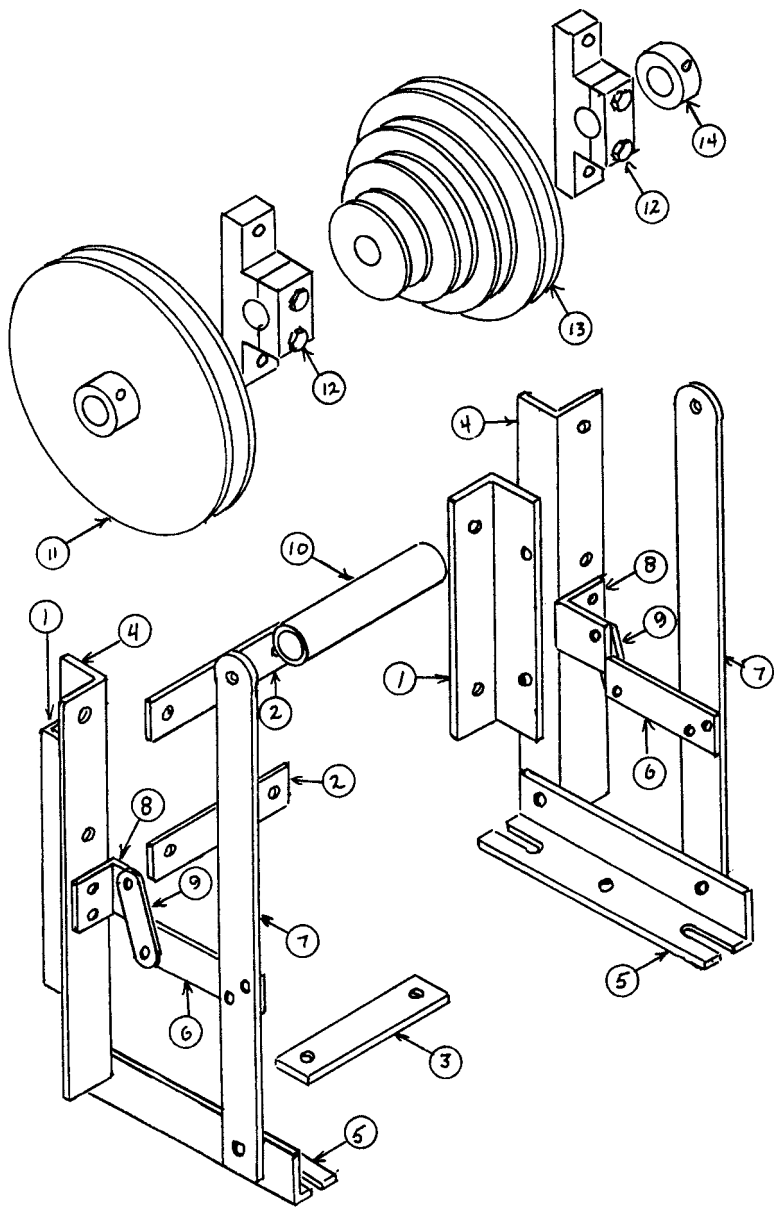

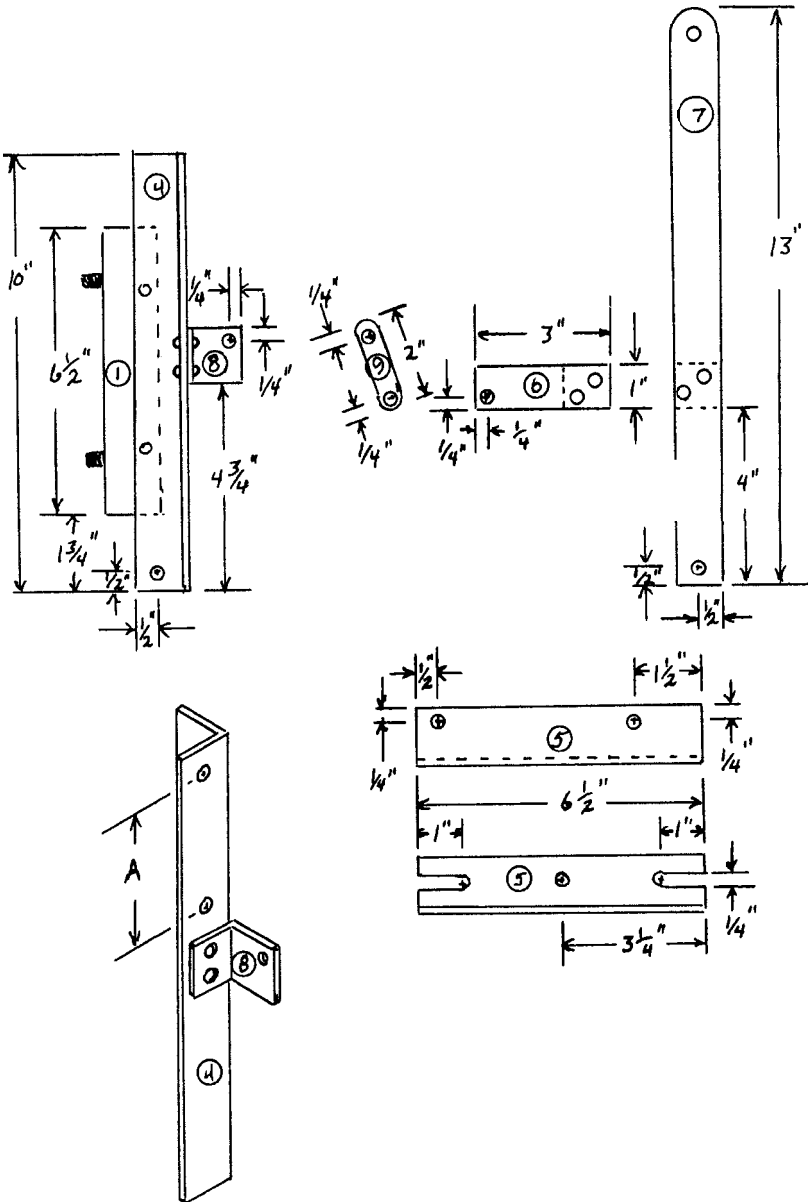

A- SPACE AND SIZE TO FIT PILLOW BLOCK, DRILL & TAP.

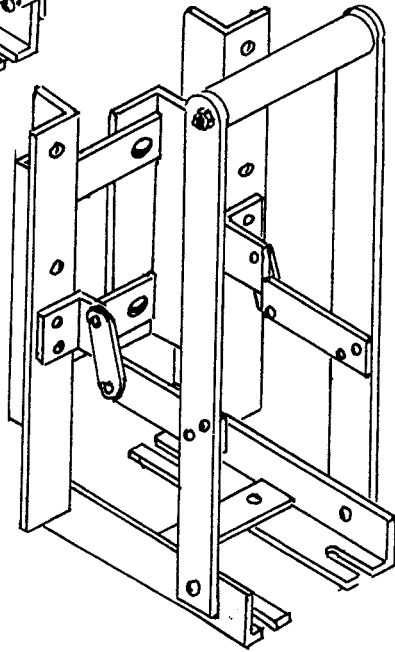
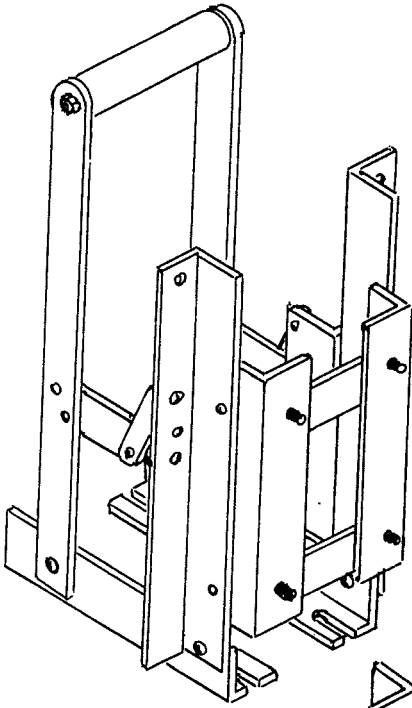

The best sequence to follow is to make the base rails first. Drill the 1/4" holes in each end for the mounting slots, cut the slots with a hack saw, and drill the pivot holes and the spreader hole. Counter-sink the spreader hole and set the base rails aside.

Assemble the upright and the motor rail, drill for the pillow block at the top of the upright, drill the pivot hole, but don't drill the rivet holes for the release lever pivot. Rivet the upright pivot to the base rail.

Assemble the release lever, the release crank, the release link, and the release link pivot; and rivet the release lever pivot to the base rail.

Clamp the release link pivot to the upright, drill the rivet holes through both members, and set the rivets.

Keep in mind that there are right and left hand members.

Install the motor rail spreaders with the bolts extending through the tapped holes in the motor rails.

Install the base spreader with rivets beat flat in the counter-sunk holes in the base rails.

Install the release handle with a length of 1/4"-20 threaded rod. If you use pipe or tube, fit a wood bushing in each end to center it on the through bolt.

The pulley drawings are shown reversed for clarity. Install them on the shaft and bearings opposite as shown.

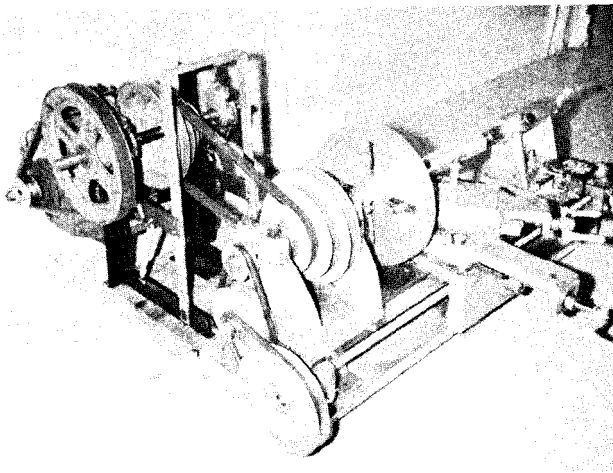

CHAPTER VII

THE HEAD STOCK

Like the bed casting, this one requires very near a full one quart pot of aluminum to fill the mold. Being a very dangerous practice, you'll want to be well prepared, and use extra caution in pouring this mold.

Because of the extra heavy section in the in-board bearing, there is a possibility of a shrink cavity in the base of the casting. It will be out of sight, and it will not effect the casting seriously. Be very certain to gate the mold at the heavy end.

While it will ultimately be fastened permanently to the bed, its base is finished with a box slide to fit the ways, so that it can travel the bed as it is bored. In this way, it is possible to establish the spindle bore on a center that is exactly parallel to the ways. A feat that would be otherwise difficult to perform without a very elaborate and expensive array of equipment.

THE PATTERN

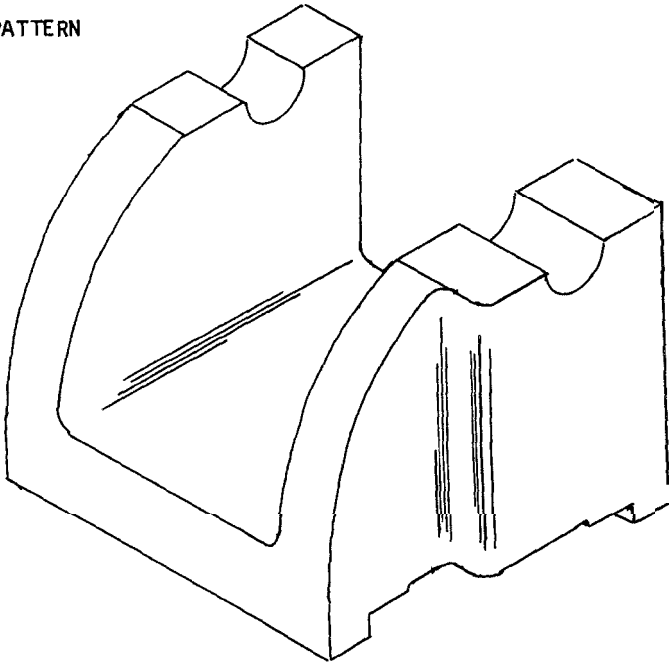

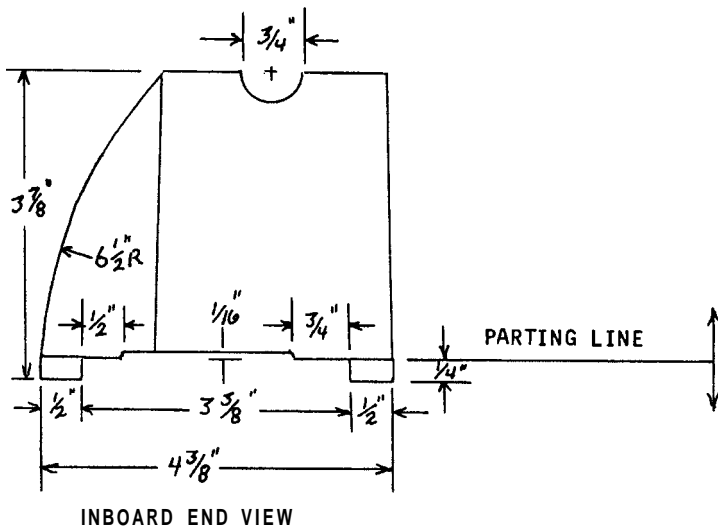
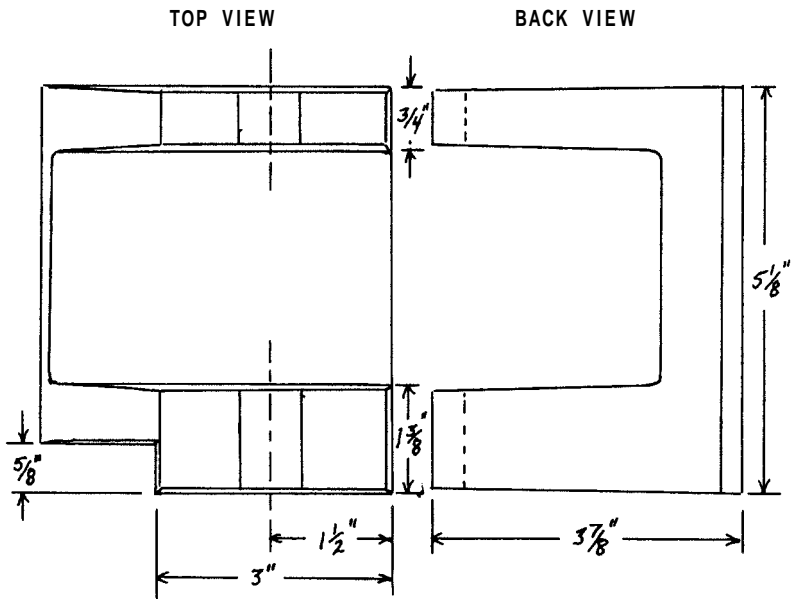

Being a relatively deep pattern, it should have plenty of draft. Notice that the sides slope slightly, both inside and outside, in the back view on page 79. There is a large green sand core between the upright members, which will be in the drag. If you don't provide draft on the inside of the members, you will be unable to withdraw the pattern.

The dimensions in the top view represent the base dimension at the parting plane. These members will taper to a smaller dimension at the top, to provide draft. A taper of $1/32"$ to $1/16"$ will be ample on all sides. Only a very slight taper is needed on the clamp pads below the parting line.

Built in six separate pieces, it is not a difficult pattern to make. It will be easier to sand the draft on the upright members before they are fastened to the base.

The wear pads can be formed by cutting out the raised area between them, or you can build them up of cardboard, as in the carriage. Notice that the back wear pad is $1/4"$ wider than the front; a gib will be installed to fit the slide to the ways.

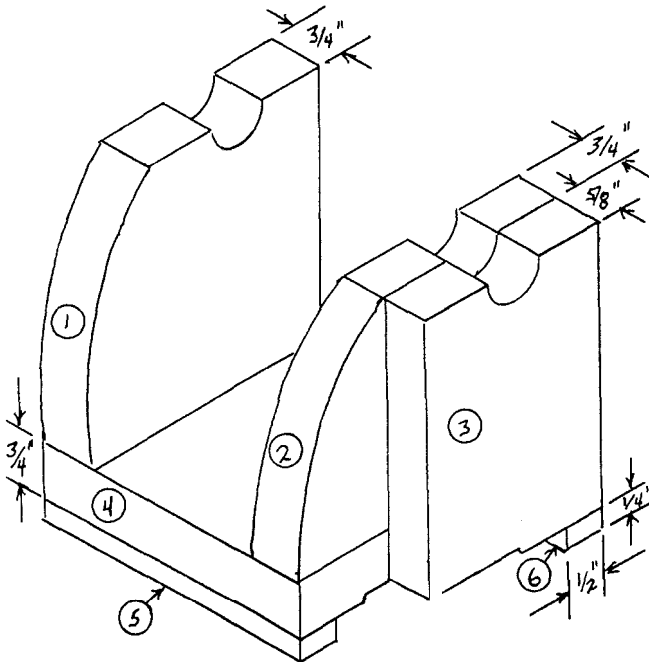

Lay out and cut the parts carefully, keep these essential elements in mind: The center of the saddle bore is 1-1/2" from the back edge of the base. The height of the saddle bore center is 3-5/8" above the wear pads. The box way is 3-3/8" wide and 114" deep. Shrinkage has been considered, so the casting will be more than 1/16" smaller in all of the major dimensions. Don't make additional allowance for shrinkage.

Form parts 1 and 2, and fasten them to the base, part 4. Add the inboard bearing extension, part 3, and add the clamp pad rails, parts 5 and 6.

Round the outside comers and form the fillets on the inside corners.

Sand smooth and seal with two coats of shellac or lacquer.

MOLDING THE HEAD STOCK

A 12" x 12" flask will handle this mold. The cope can be 3" deep, but the drag must be 6" deep.

You could prepare a follow board to accept the clamp pads, or you can bed the clamp pads in a false cope. The main body of the pattern will be in the drag, only the clamp pads will be in the cope.

Ram up the drag in four or five layers, to be sure it is thoroughly done. Be especially sure to make the cores for the saddle bore firm., Vent generously with the wire.

When you roll over and remove the false cope, or the follow board, only the clamp pads will be above the drag sand. There will be a ragged edge on each end, so you must cope down to the recessed surface between the wear pads.

Set a 1" sprue pin about 1-1/2" away from the inboard end of the pattern, which is the heaviest end.

Ram up the cope, and push a 1/4" dowel through the sand, to rap the pattern before you open the mold. After you rap the pattern, you can push some sand into the rap hole with the dowel.

Open the mold, screw a draw peg into the base of the pattern, swab the pattern, rap, and withdraw carefully.

Cut a gate from the sprue print to the cavity, about 1/4" deep and 1" wide.

Close the mold and pour as fast as it will accept the metal.

Allow this one to cool for at least an hour before you shake it out.

FINISHING THE HEAD STOCK CASTING

The base of the head stock is scraped to fit the ways in the same manner as the carriage. Clamps are fit to the pads, and a gib is installed in the back way. Only two gib screws are needed to adjust for a smooth sliding fit, with no play in any direction.

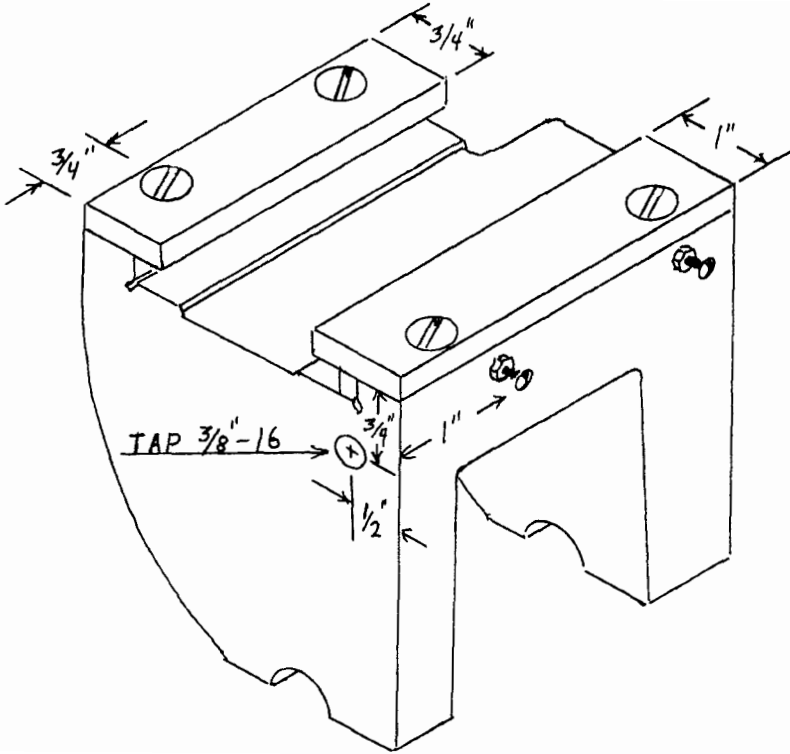

Each clamp is held with two **114"-20** flat head screws. Notice that the front clamp is $\frac{3}{4}$ " wide, and the back clamp is 1 " wide to accommodate the **114"** square gib. The gib screws are #10-24.

The **318"-16** tapped hole is for the stud that carries the reduction pulley in the carriage drive train. It will be easier to drill and tap the hole before the head stock is installed on the ways. It should be as near parallel to the ways as possible, so the reduction pulley will run true.

THE HEAD STOCK BEARING CAPS

Simple wooden patterns, glued to a $\frac{3}{4}$ " dowel rod, and molded just as you did the lead screw bearings. Cast on a $\frac{3}{4}$ " steel rod, the half bore will be smooth and true.

Such small patterns are difficult to mold separately, and if you fit them to the dowel as it rests in the saddle bore of the head stock, the bore will be well aligned.

Take the base dimension for the caps from the head stock pattern.

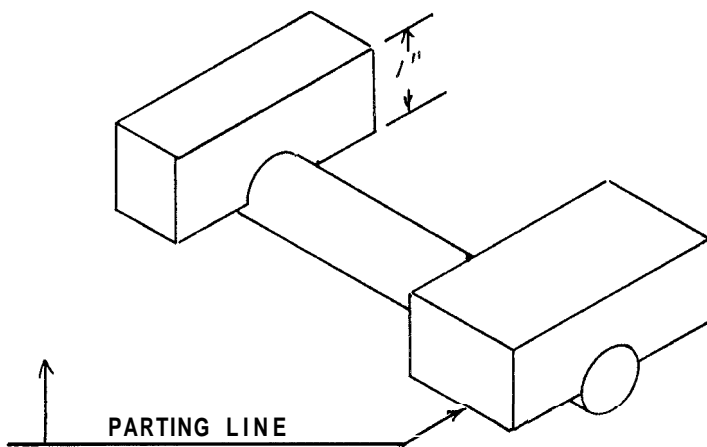

FITTING THE BEARING CAPS

The mating surfaces of the bearing caps and the saddle bore of the head stock are filed and scraped to a good fit.

The half bore in the caps will be smooth, but the saddle bore will be rough. Scrape the saddle bore so that a $\frac{3}{4}$ " steel mandrel will fit fairly well.

Cut some shims from sheet aluminum to place between the mating surfaces. These shims will be a permanent part of the head stock, to provide a means to adjust the bearings as they wear in use. Each of the four groups of shims should include three or four of .001" thickness, which can be brass. Use the shims to bring the bore back to a good fit on the $\frac{3}{4}$ " mandrel, after you have filed and scraped the mating surfaces.

Clamp the caps to the head stock, with the mandrel in the bore, and drill and tap for 5/16"-18 cap screws. The mandrel does not have to fit precisely; it is used to hold the caps in alignment while they are drilled. This is another job where step drilling proves its worth. Begin with a pilot drill, enlarge to tap size, drilling through the cap and into the head stock; remove the cap, enlarge its hole to bolt size, and tap the hole in the head stock. Drill at least 1" into the head stock, but don't try to tap all the way to the bottom of the hole. 3/4" deep will be enough threads for the cap screws.

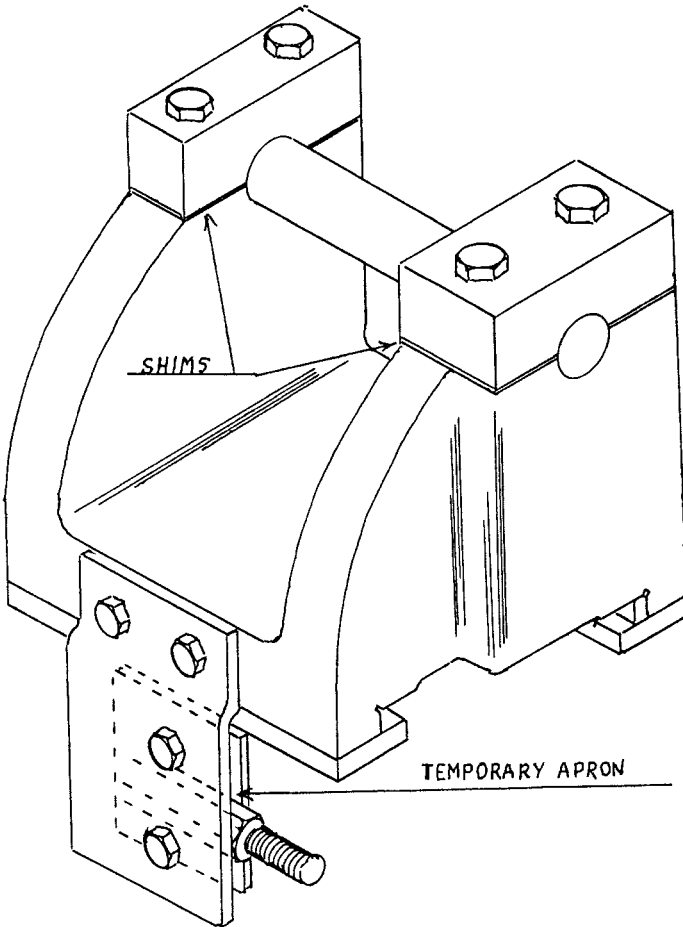

THE TEMPORARY APRON

A piece of 118" steel, approximately 2" x 3" bolted to the head stock and anchored to the coupling nut with a "U" bolt or a pair of bolts through a plate. It will be necessary to bend an off-set, or use a spacer between it and the head stock casting, to bring its inside surface to meet the coupling nut.

This is what we use to drive the head stock during the boring operation. It will be removed and discarded when the boring is finished.

The lead screw will be operated by the hand crank for this operation; we can use the power drive to bore the tail stock casting.

BORING OPERATION THEORY AND PRACTICE

The alignment of the component parts with respect to the ways and each other is the main challenge in building a machine tool. It is at this point that you begin to receive your wages for the care you exercised in scraping and fitting the parts to the bed ways.

Without a very elaborate and expensive array of equipment, you could not possibly install a boring bar to travel exactly parallel to the ways. There would certainly be an error, and that error would be repeated in the saddle bore. If the error were as slight as one degree, it would cause the centers to be **mis-aligned** by nearly 1/2".

Instead of passing the boring cutter through the work, we fix it rigidly in one position and drive the work over the boring cutter. Because the cutter rotates on the same center continuously, as the work travels past, it makes a series of cuts that are exactly parallel to the ways.

Even if the boring bar bearings are out of alignment by as much as 1/8", the axis of the cutting circle would only be shifted about one degree. This would produce an ellipse so slight, that it could only be measured with very fine instruments. The series of elliptical cuts will still be parallel to the ways, which is our main consideration.

When the head stock has been bored, it is fit with a set of bearings to support the boring bar as it bores the tail stock. The result is near perfect alignment of the spindles.

THE BORING BAR SUPPORTS

While these parts could easily be cast in aluminum, I used 1/4" angle iron from my scrap box. I also purchased a pair of 5/8" pillow block bearings with bronze sleeve bearings.

The bearings I used have mounting holes on 2-7/8" centers, and the bore is centered 1" above the base. Other sizes will work as well, but you may have to change dimensions of the supports.

The object is; to support the boring bar at a center height of 3-1/2" to 3-5/8", depending on the finished dimension of your head stock, and approximately 3/4" forward of the back ways. To this end, the supports are made adjustable vertically, and they are provided with slots for the bearing bolts to allow horizontal adjustment.

VIEW AT TAIL STOCK END

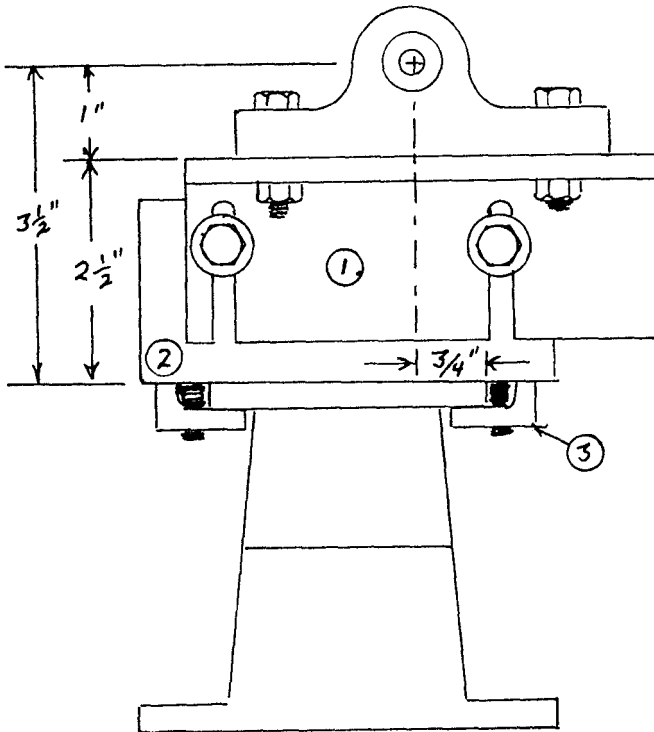

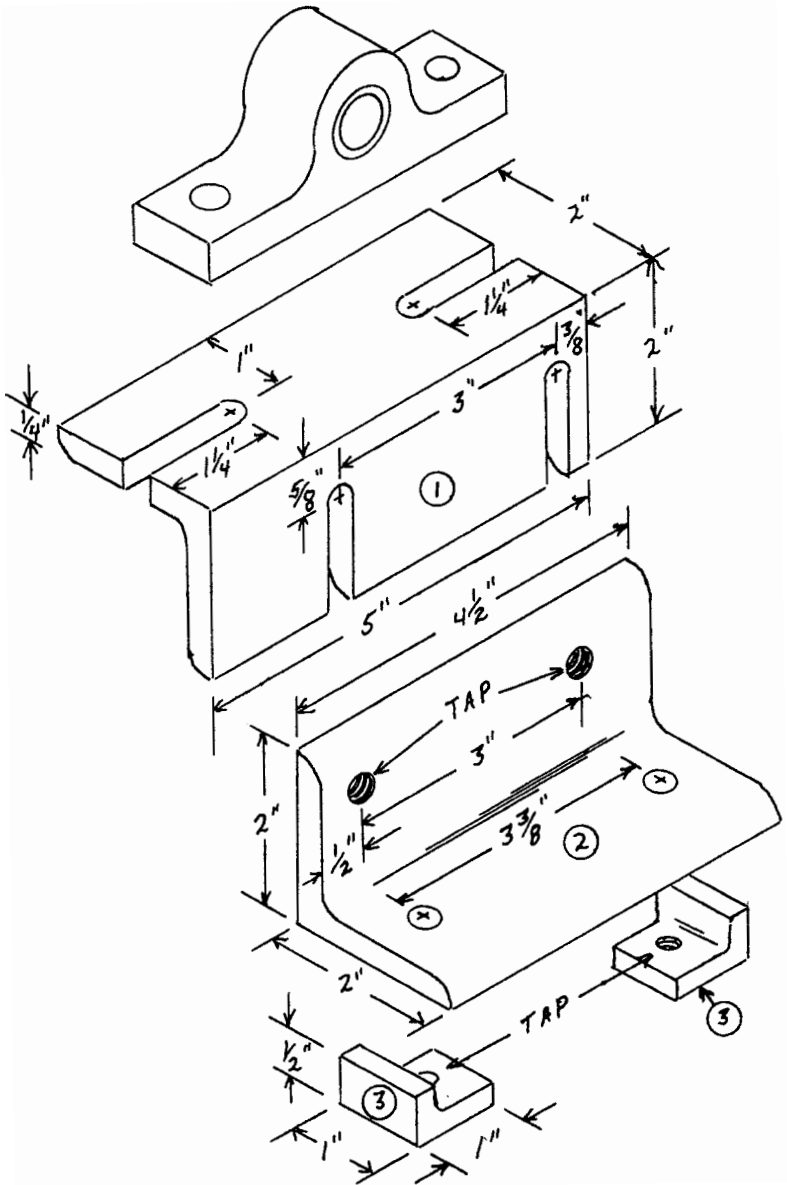

TWO SETS REQUIRED; ONE RIGHT HAND AND ONE LEFT HAND

Made from 2" x 2" x 1/4" angle iron, there is a right hand and a left hand support assembly. The slots are formed by drilling on the centers indicated, and cutting with a hack saw. Use 1/4" or 5/16" bolts for the pillow blocks and the vertical adjustments.

The small angles that serve to clamp the support to the ways are cut from 1/4" angle iron. Use 1/4" bolts for the clamps.

These assemblies provide a solid support for the boring bar, and they turn out to be a handy accessory for the lathe. They can be used as a steady rest until you make a better one,

Mount the assemblies on the bed, as shown below, and mount the counter shaft and motor to drive the step pulley.

The boring will be done with the lowest speed.

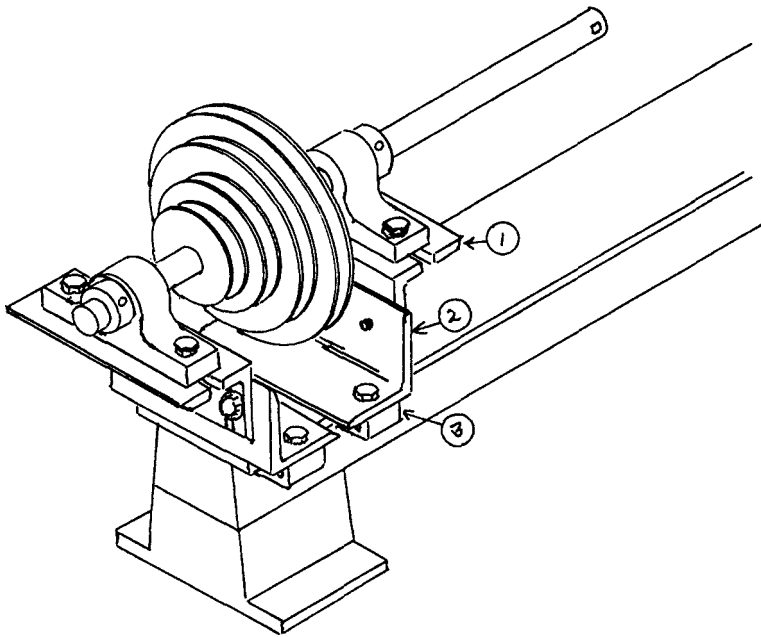

THE BORING BAR

Made of $5/8$ " cold rolled steel round stock about 15" long. It requires a $1/4$ " square hole through the diameter in one end, and a $1/4$ "-20 tapped hole in the end for the set screw.

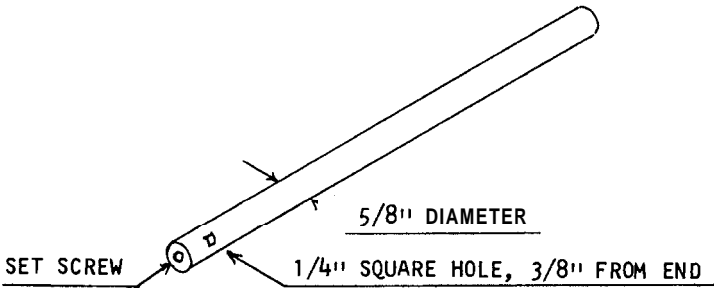

Simply step drill a $1/4$ " hole through the diameter, $3/8$ " from one end of the shaft, and using a $1/4$ " square lathe bit for a gauge, file the hole square.

It is easy to get the hole bell shaped, so test with the gauge frequently, and do your best to end up with a smooth sliding fit.

You can improvise a small safe edge file by grinding the sides of a small three cornered file.

When the lathe tool bit will slip freely through the hole, step drill and tap the set screw hole in the end of the bar.

THE BORING CUTTER

You will have to cut a piece of lathe tool off in order to have a cutter bit that is about $5/8$ " long.

Being made of hardened high speed steel, you can only cut it by grinding a groove around it and breaking it off.

Cool the tool frequently as you grind on it; it must not get too hot to hold in your hand or it will be ruined.

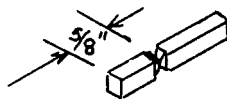

A round nosed cutter that will cut in both directions of travel is the best idea for this job. You will be running the lead screw with the hand feed, so it will help to be able to make a cut on both passes.

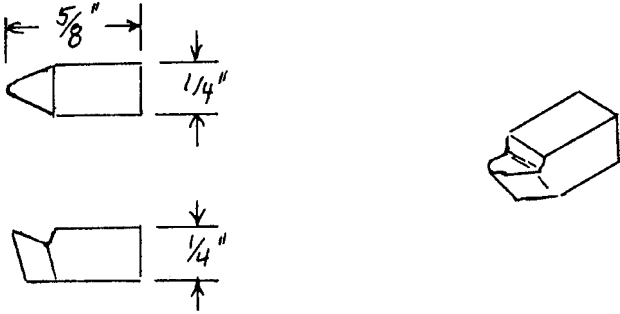

There is no side rake to this cutter, only back rake. The nose is ground to a small radius. You want a razor sharp edge for a smooth cut, so grind on a fine wheel and finish the edge on a whetstone.

If you are not familiar with tool grinding, get a text and learn it now; your lathe will be of little value until you learn to shape the many different types of cutters.

An excellent manual entitled "How To Run A Lathe" published by South Bend, and available from Lindsay publications at about \$7.95, is the best I've seen. It will teach you tool grinding and all manner of set up and operations.

An enlarged view of the cutter in the bore will show you what you are trying to do as you grind it to shape.

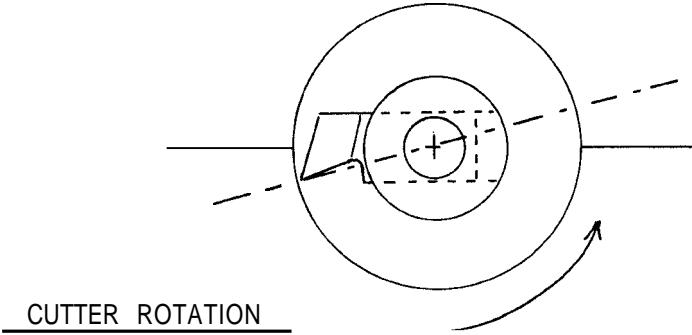

SETTING UP THE BORING BAR

The first step is to establish the center of the bar on the turning center of the lathe.

The nominal size of this lathe is 7". That means a center height of 3-1/2" above the ways; the actual height may be slightly more. The pattern was made with a center height of 3-5/8" and you may not have used up the entire shrinkage and fitting allowance. Mine turned out to measure 3-9/16", so I have a 7-1/8" swing.

The vertical center of the bore is planned at 3/4" forward of the back ways; Again, there may be a difference, so measure to be sure.

You can make a set up gauge out of heavy sheet metal, to hold the boring bar as you adjust the bearing supports.

The gauge is designed to support the bar on the horizontal center, and stop it at the correct distance from the back edge of the ways. Since the boring bar is 5/8" in diameter, we deduct half its diameter to find the correct dimensions for the gauge.

$$3 \frac{9}{16}'' - \frac{5}{16}'' = 3 \frac{1}{4}''$$

$$3/4'' - \frac{5}{16}'' = \frac{7}{16}''$$

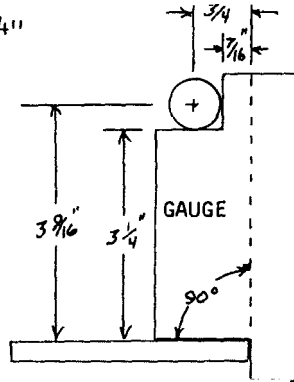

Make the gauge carefully, being especially certain to erect the vertical center line at 90 degrees to the bed.

The boring bar over-hangs the supports by 6" so that it will reach through both saddle bores in the head stock. Use the gauge to set the bar parallel to the bed ways, and on the correct vertical center. Re-check after tightening the adjustment bolts. Rotate the bar to make sure it is not bent.

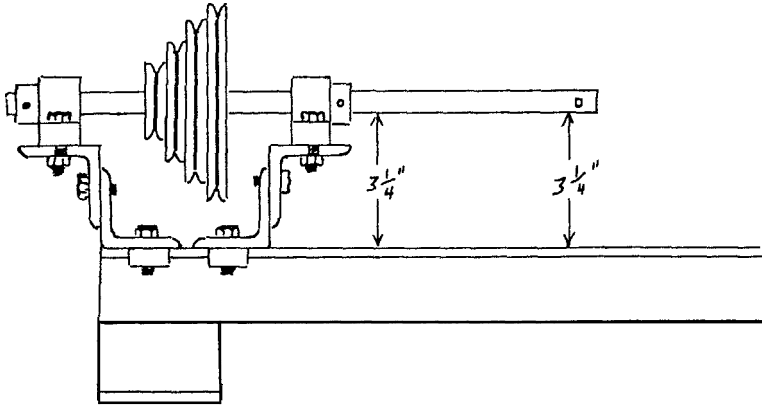

Take your time to do this setting up. By checking each end of the over-hanging bar alternately, you will be able to position the bar very accurately.

With the lathe bolted to the bench, the counter shaft connected to produce the lowest speed, and the head stock in position on the ways, you are ready to begin boring.

Without doubt, the first cut will be rough, perhaps the second and third also; but make each cut all the way through both saddle bores without changing the cutter setting. Using the crank on the end of the lead screw, run the head stock past the cutter at a slow even rate. You can make a cut on both the forward and return travel. It will be best to make relatively light cuts of about .010" on each pass.

GAUGING THE BORE

There are beautiful precision instruments for gauging the work, lay-out, and setting up operations. Most of them are far too expensive for the home shop operator. Many are quite complicated to use, and the need for them arises so seldom in the home shop, that we can't justify them.

Remarkably accurate work can be done with simple calipers, available for as little as two or three dollars. A simple vernier calipers, made by General Tools, is available at most hardware departments for only a few dollars. While its finest reading is $1/128$ ", in the hands of a careful man, precise work can be done.

If you have access to fine instruments, by all means use them and enjoy them you lucky dog, but if not, here are some ways you can do the job without them:

The simplest of all is the adjustable calipers. You can get them in several styles, and, while the adjusting and locking devices are superior on some, and the best ones are made of high grade material, it is the delicacy of the touch that determines the accuracy of the work. In a class situation, ten students can use the finest micrometer in the world to gauge an object, and they will arrive at ten different readings. They have not yet developed the sense of touch that is required for precision work. The only advantage in using a micrometer over a calipers, is the graduated scale. If you have the mating part on hand, it will serve as an excellent gauge, and its measurement in standard units is of no importance. You can transfer the size from one member to another without ever converting to standard units of inch or metric measurements.



MEASURE OUTSIDE

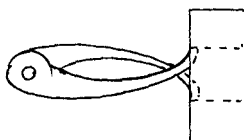

MEASURE INSIDE

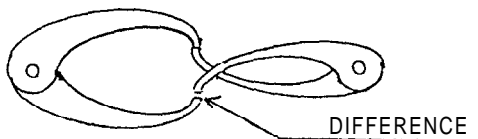

DIFFERENCE

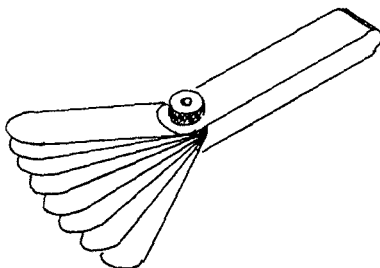

FEELER GAUGE

The head stock is to be bored to 1" diameter, to accept a 1" x 3/4" bushing. The outside diameter of the bushing will serve as the gauge standard; we want the hole to be about .001" smaller.

Bronze bushings that are finished to size both inside and outside are available from industrial bearing supply houses, hardware stores, and W. W. Grainger Co. Be sure to specify "finished both inside and out", a semi-finish bushing is of no use if you don't have the equipment to do the finishing work.

Referring to the sketches on page 93, measure the outside of the bushing, which transfers the measurement to the calipers. Measure the inside of the saddle bore and compare to find the difference. The difference is the amount that must yet be removed to fit the bore to the bushing.

In the early stages of boring the difference will be great enough to be obvious to the naked eye. Near the end of the job, you will need to know exactly how much to advance the cutter in the boring bar. The simple feeler gauge will serve to transfer the final measurement to the boring bar cutter.

SETTING THE CUTTER

This simple adjustable gauge will enable you to advance the boring bar cutter a precise amount. It is clamped to the boring bar with the adjusting screw in line with the cutter bit. If you want to advance the cutter .010", you slip a .010" feeler gauge between the cutter and the screw. Adjust the screw so that the feeler fits with no play and no drag. Remove the feeler and advance the cutter to touch the screw.

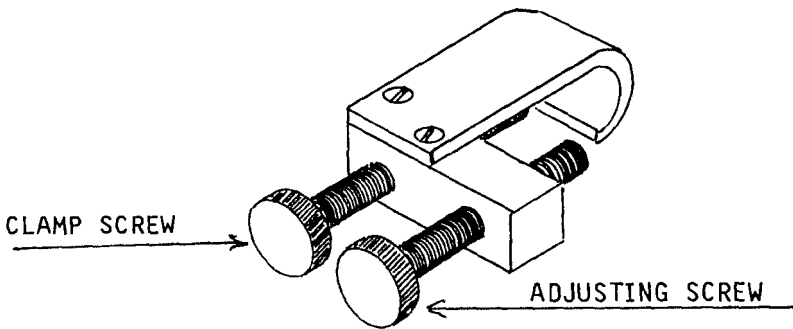

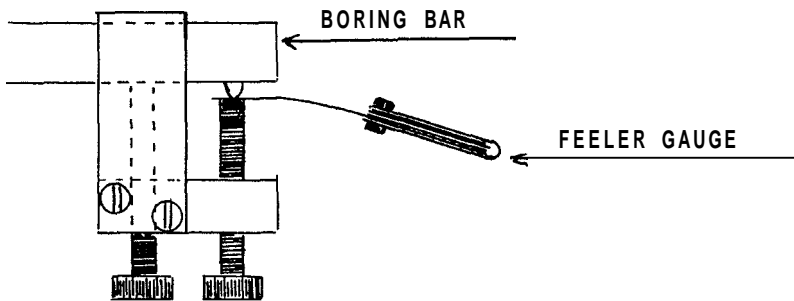

The body of the tool is a 2" length of 5/8" steel key stock. The clamp is 1" x 1/8" steel strap, fastened to the body with two # 10-24 screws. The clamp screw and the adjusting screw are 1/4"-20 threaded rod with thumb nuts on the end. The screw holes, tapped in the body, are located 1/2" from each end. The adjusting screw hole should be deformed by striking the body with a hammer, so there will be a slight amount of drag in the screw fit.

Keep in mind that when you gauge the hole with the calipers and feeler gauge, you are finding the difference in the diameter. The cutter gauge is measuring on the radius, so you advance the cutter one half the difference in the diameter. For instance; on your last test you find the difference in diameter to be .012", so you advance the cutter .006" to finish the bore.

The shims that were installed with the bearing caps will provide for adjustment if you bore slightly over the size of the bushing, but do your best to finish .001" under size.

Use the gauges with each pass, to measure the bore and to advance the cutter, so that you develop your sense of touch. Make notes and compare each change in the diameter of the bore to see if you actually removed the amount you intended to. In this way you can correct your technique so that you can accurately predict what each cut will do.

The end of the adjusting screw should be slightly convex and filed very smooth. The clamp must fit the boring bar without play in any direction.

When the bore is correct, you can loosen the caps to slip the bushing in the bore. A 3/4" shaft should turn in the bushing with very little drag when the caps are tightened. Minor adjustments to the fit can be made by adding or removing shims.

The permanent spindle will have a 3/4" diameter at the inboard end, and a 5/8" diameter for the pulley and the outboard end. Details will be discussed later; for now, the saddle bore will be fit with 5/8" bearings to carry the boring bar as a temporary spindle.

A finished 3/4" x 5/8" bronze bushing is slipped into a 1" x 3/4" split steel pulley bushing to reduce the saddle bore to 5/8".

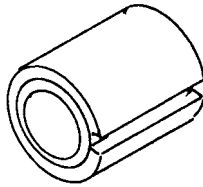

ANCHOR THE HEAD STOCK

While the tail stock could be bored with the same set up that was used for the head stock, the finished head stock will provide a better support for the boring bar. Also, it will be an advantage to anchor the head stock and complete the power drive train for the lead screw, so it can be used for the remaining operations.

Remove the boring bar supports from the bed, dismantle the temporary apron and discard it, and run the coupling nut to the left end of the screw. The coupling nut will not interfere with the carriage so there is no need to remove it from the screw, just tighten it against the left end jamb nut so it won't wander down the screw.

It will be necessary to dis-mount the bed from the bench and remove the left end mounting base and stud to install the head stock anchor bolts.

Slide the head stock to its permanent position at the extreme left end of the bed ways. It should not over-hang the ways; in the later development of the lathe, you will want the left end to be clear for the addition of the change gear mechanism.

With the head stock clamped in position, use a 5/16" drill to extend the mounting base stud hole through the head stock casting. Follow the drill with a 3/8"-16 tap, to extend the threads into the head stock. Replace the original stud with one that is long enough to reach into the head stock and leave an anchor stud for the base.

Using the elongated hole in the bed casting as a guide, step drill another 5/16" hole through the ways, and at least an inch into the head stock casting. Follow with a 3/8" drill through the bed ways, but don't run it into the head stock casting. Tap the head stock for 3/8"-16, but be careful, you are tapping a blind hole and it would be a real disappointment to break off a tap at this point. A thread depth of 3/4" is ample, so don't try to tap to the bottom of the hole.

Install a 3/8"-16 x 1-1/4" cap screw, with a flat washer and a lock washer. Don't over-tighten the bolt or the stud nut; to do so will distort the ways.

Re-install the mounting base. At this point, you can mount the lathe in its permanent location, and line up the counter shaft with the head stock pulley, using the boring bar as a temporary spindle to carry the head stock pulley.

Remove the cutter from the boring bar, and with a left hand turning tool in the tool post, reduce the end of the boring bar to 1/2" for 3" of its length. This will make it small enough to enter the core hole in the tail stock, and it will provide a 1/2" arbor on which to machine the pulleys for the power drive train.

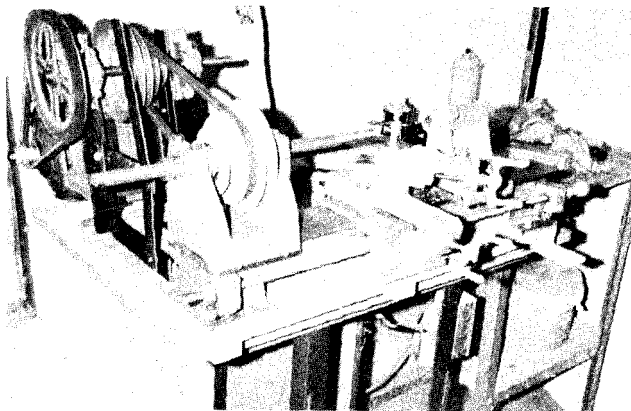

CHAPTER VIII

THE LEAD SCREW DRIVE TRAIN

A double reduction belt drive from the spindle to the lead screw is a simple way to automate your lathe. Later, when your metal shop is more developed, you can add change gears for cutting right and left hand threads.

THE DRIVE BELTS

Power is transmitted to the lead screw through two vacuum cleaner belts. The ones I used are for a Hoover machine. They are intended to drive the rotating brush in the suction head. They are a round section belt, about 5/16" thick, and they measure about 3" inside diameter. This type of belt must be stretched very tight in order to work well.

THE REDUCTION PULLEY ARBOR

The 3/8"-16 hole that is tapped in the left end of the head stock will accept a lawn mower wheel axle of the same type that was used for the tool post. It has a 1/2" diameter on the shank, and the threaded portion is 3/8"-16.

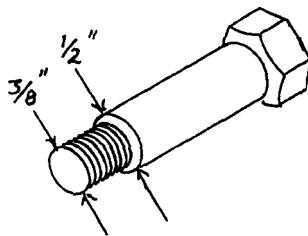

THE SPINDLE DRIVE PULLEY

A 1" x 5/8" bore pulley which can be cast in aluminum or pot metal, to be machined on the lathe or, you can cut down a die cast pulley. The narrow portion of a standard "A" pulley is just about right for a 5/16" round belt. Just lock the pulley on the temporary spindle to machine it to size.

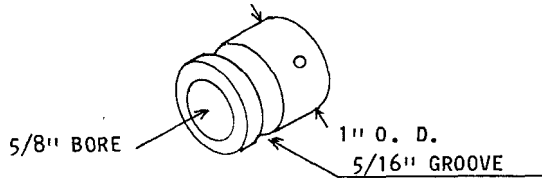

THE SPINDLE DRIVE PULLEY

THE REDUCTION PULLEY

THE REDUCTION PULLEY

A 4" diameter pulley, using a 1" diameter hub for the reduction step. You can make it with a 5/8" bore to accept a bronze bushing to fit it to the 1/2" arbor, or you can make it a 1/2" bore to be used without a bushing. The pulley turns very slow and the load is light.

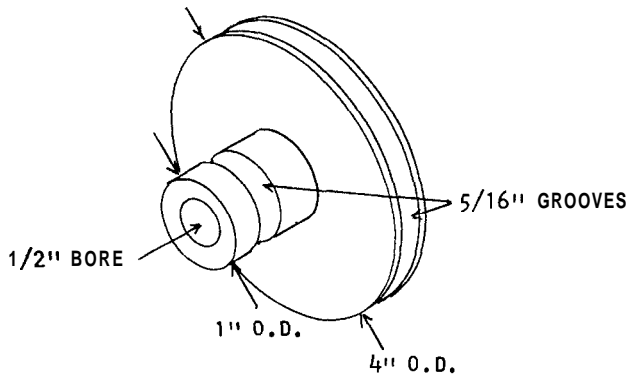

You can cast it on a steel arbor, or you may be able to find a die cast pulley of about 4-1/2" diameter, that has a large enough hub for the reduction step. In either case, it is a simple matter to lock the pulley to the temporary spindle with the set screw and machine it on the lathe. In use, the set screw is discarded; this pulley is meant to turn freely on its arbor.

THE LEAD SCREW PULLEY

A near duplicate of the reduction pulley, except that it uses the set screw to lock it to the lead screw journal.

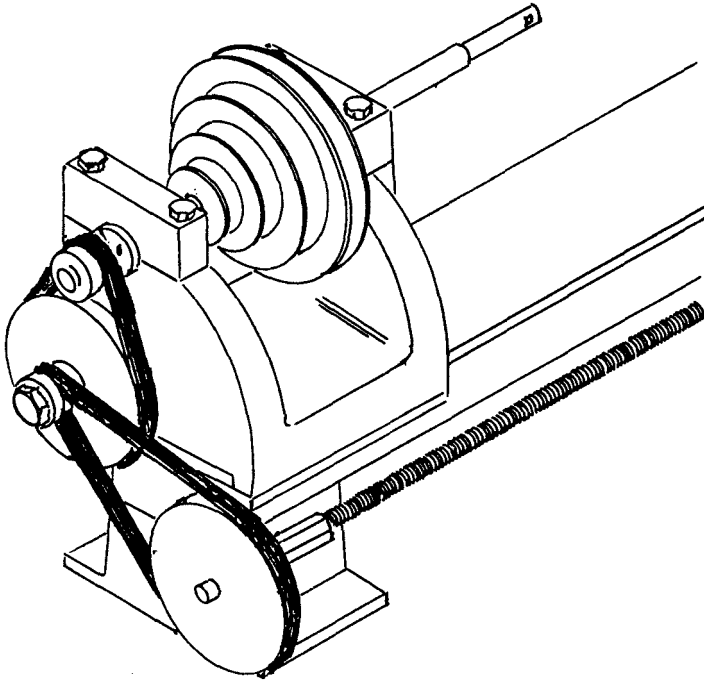

The reduction ratio is about 16:1 through both stages. This gives carriage feed of about .003" per revolution of the spindle.

This feature will greatly broaden the usefulness of the lathe, and it will make the boring of the tail stock much less tedious.

At any time that you want to use the hand feed, just remove the second stage belt to free the lead screw.

A WIDE RANGE OF CAPABILITIES

At this point, you have built a lathe that is as complete as some that are sold commercially. If you have been in the market for a lathe very long, you are not surprised to learn that some lathes are sold without a tail stock. I could hardly call a tail stock an accessory, as some do, but the partially finished lathe can do many jobs now.

CHAPTER IX

THE TAIL STOCK

Using just two aluminum castings; the only technical problems are the baked sand core and, a somewhat complicated parting line. Neither problem is serious, for by now you have enough skill and knowledge to handle them.

THE TAIL STOCK BASE CASTING

This is the easiest part and it is best to complete it and fit it to the ways before the main body of the tail stock is made.

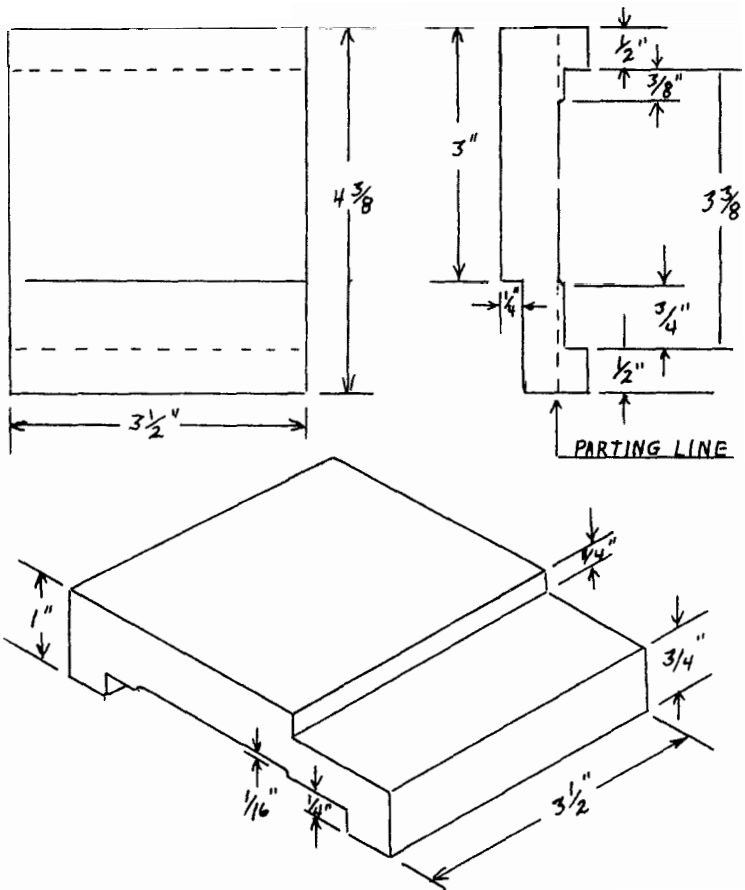

A very simple pattern to make, and just as simple to mold and cast.

Notice that the front wear pad is 3/4" wide to allow for the 114" gib.

The front portion of the base is dropped to provide clearance for the clamp screw head.

Again, the parting plane is at the raised portion between the wear pads. Provide draft both above and below the line.

MOLDING THE BASE CASTING

Simply rap the rails into a blank drag until the pattern rests on the parting line. Set a 1" sprue pin about 1-112" away from the rear edge, and ram up the cope.

It will be best to push a 114" dowel through the cope sand, to rap the pattern before you open the mold. The hole can be left as a vent, or re-filled with sand.

Open the mold, cut a gate from the same print to enter the rear edge, which is the heaviest portion of the casting.

It's a temptation to pour a simple figure like this with a single pop gate on the top surface. To do so will leave a shrink cavity around the sprue, which makes for a tougher finishing job. It takes little effort to cut the gate, and the later savings in work is worth the effort.

FINISHING AND FITTING THE BASE CASTING

The wear pads and clamp pads are filed and scraped to fit the bed ways in the same manner as the carriage.

The top surface is filed and scraped smooth and flat to accept the set over ways. Use a portion of the bed ways as a test standard. The bottom of the tail stock casting will fit this surface; it should be as near parallel to the bed ways as possible.

The steel clamps are fit to allow a free slide on the ways, with no play. The back clamp is held with three 1/4" flat head screws. The front clamp is held with two 1/4" screws. The 318"-16 clamp screw is installed on the left end of the base because that is where the greatest strain is. This top tightening screw is superior to the usual gib clamp that is found on solid ways.

Fit the base to the ways, install the clamps and the gib, adjust the gib screws for a free sliding fit, with no play, and install the clamp screw last.

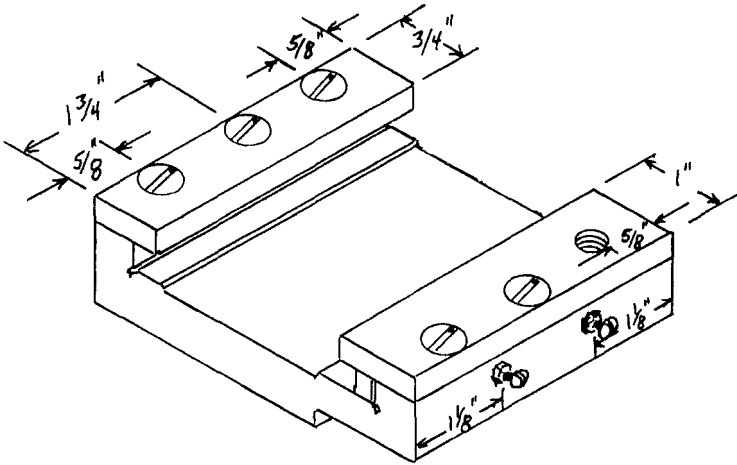

The front clamp screws are spaced the same as the back clamp screws. The gib screws are #10-24 machine screws.

The 3/8" top tightening clamp screw is located 5/8" from the left end, and it is centered to clear the front edge of the ways by a small amount. This center must be found with the base installed on the ways.

The gib is 1/4" square key stock, 2-5/8" long.

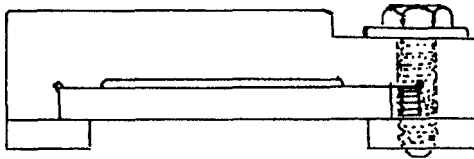

Locate and step drill the hole carefully to avoid damaging the ways. Only the steel clamp is tapped; enlarge the hole in the base to bolt size.

THE SET OVER WAYS

A slab of $1/4"$ x $2"$ cold rolled steel, $3"$ long, fastened to the base with two $1/4"$ -20 flat head screws.

The base should be removed from the ways before you drill and tap the holes; but before you remove it, mark a clear line $5/8"$ from the left end, to locate the position of the set over ways. This line should be at exact right angle to the bed ways.

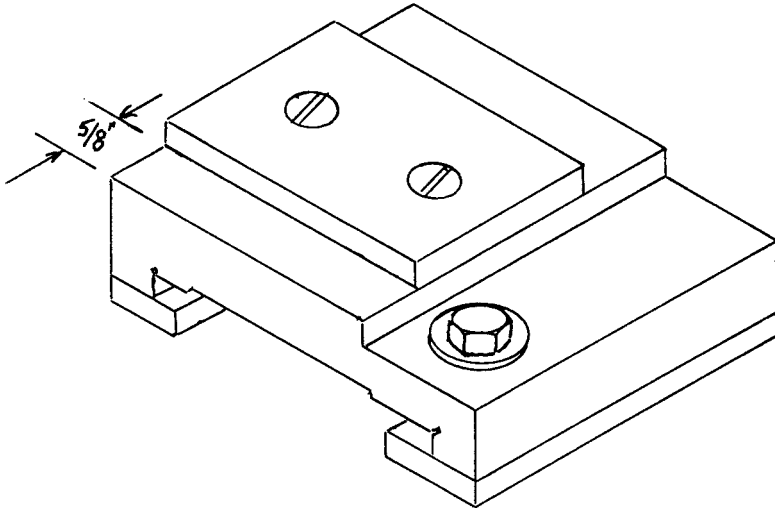

THE MAIN BODY PATTERN

With the base fit to the bed, you have a more accurate point from which to establish the height of the tail stock center. The main body pattern can be fit to the finished base, and its center established $3/32"$ above the head stock center, to allow for shrinkage in the casting.

While it is a little more intricate than some of the other patterns, it is not difficult to build.

Note that the parting line begins at the lower front corner, and passes through the center of the core print. This will become more clear as we move along. This casting is an excellent exercise in the metal casters art. It provides a range of experience that will be of great value in developing your skill and knowledge.

The center height should be determined from the top surface of the base casting to the center of the head stock spindle. $3/32''$ is added to allow for shrinkage and finishing.

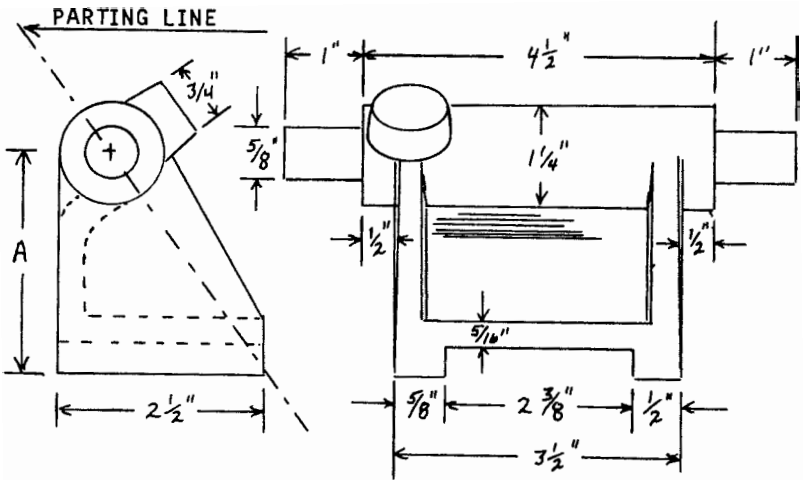

$A = \text{CENTER HEIGHT} + 3/32''$

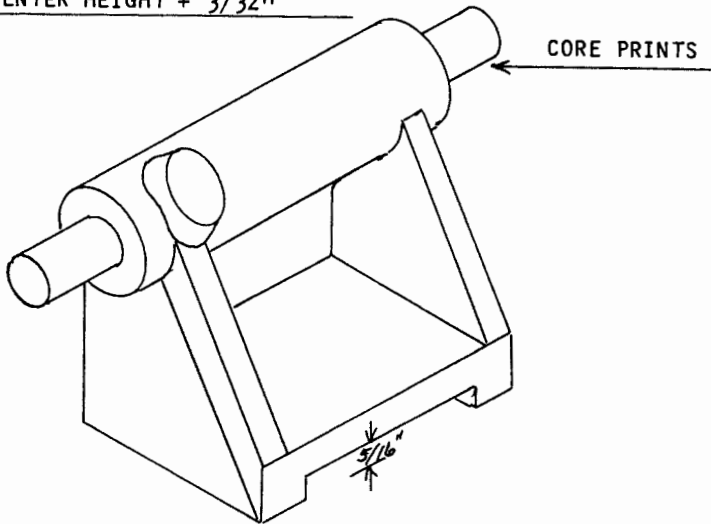

The section thickness of the pattern is $\frac{5}{16}$ " throughout. The $\frac{3}{4}$ " diameter raised boss is for the bolt that locks the tail stock ram. It is set at 90 degrees to the parting line and it is slightly larger where it intersects the barrel of the tail stock, to provide draft.

Notice the dotted line representing the back section curves forward to intersect the barrel. This provides an even section thickness to avoid a shrink cavity.

The body of the pattern is $\frac{1}{8}$ " wider at the front to provide draft. The portion of the uprights forward of the parting line is beveled on the outside only on both ends.

The $\frac{5}{8}$ " diameter core prints will leave a print in both the cope and the drag. A baked sand core, 6- $\frac{1}{2}$ " long, will be placed in the print to provide the rough bore in the barrel.

BUILDING THE PATTERN

You can provide yourself with some $\frac{5}{16}$ " white pine stock by ripping $\frac{3}{4}$ " stock.

The layout of the end sections can be done on the surface of the stock, and both ends cut together, to make an identical pair. There is a right and left hand member.

A= HEIGHT FROM BASE TO CENTER OF HEAD STOCK SPINDLE+ $\frac{3}{32}$ "

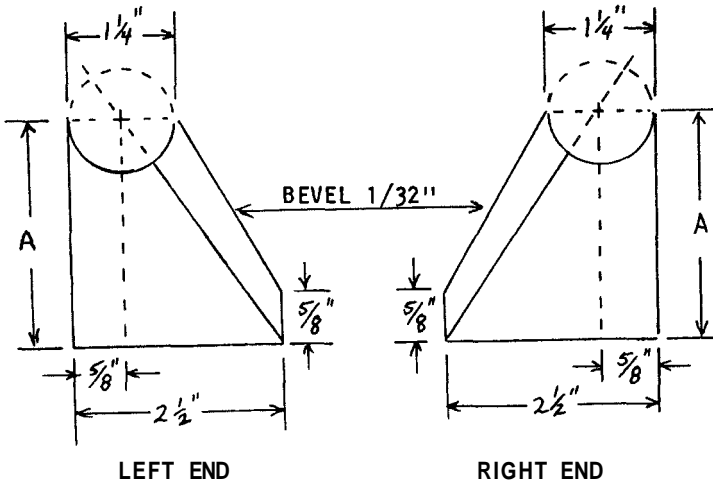

The base is cut $\frac{1}{8}$ " wider at the front. The end members are fastened to it with glue and brads. The taper gives the proper draft both inside and out.

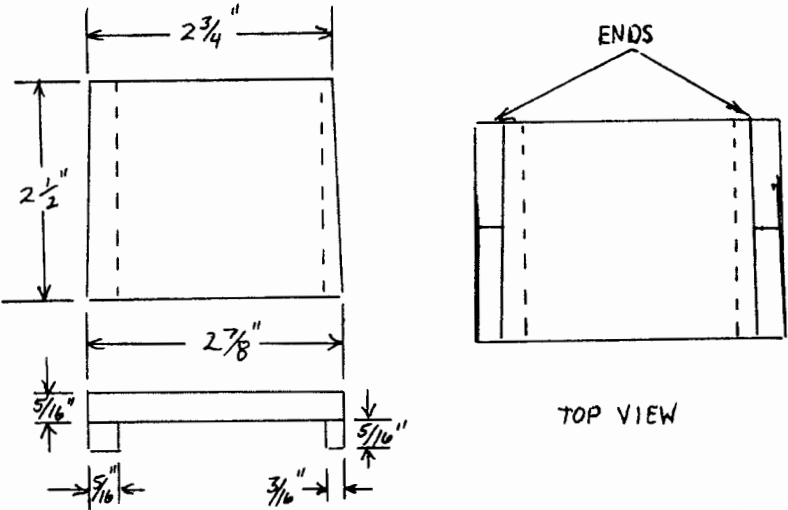

The back member can be cut from a piece of $\frac{3}{4}$ " stock. It is fastened between the ends with glue and brads.

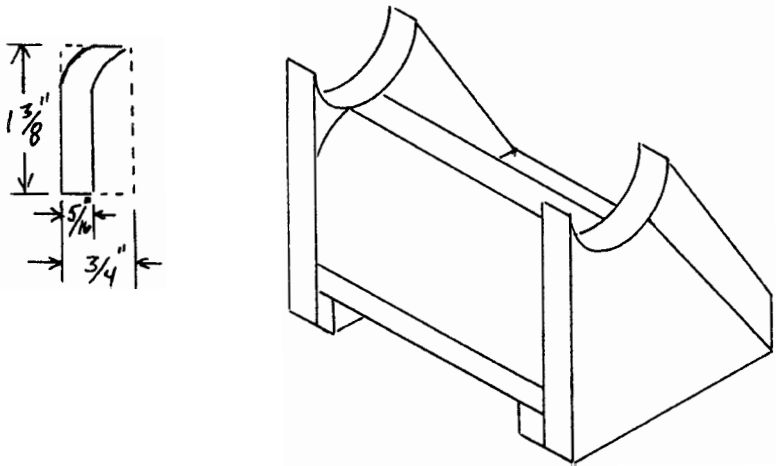

The barrel and core prints can be made from a 6-1/2" length of 1-1/4" closet pole, available at most building sites as scrap.

Lacking a wood lathe, I cut the core prints on a table saw, setting the blade for a 5/16" depth and making multiple passes with the stock held on the miter gauge.

It is important to have the core prints concentric to the barrel. If you have a wood lathe, it's a simple turning job.

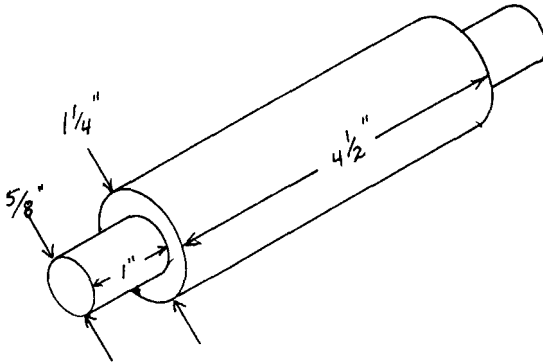

When it is finished smooth, set the pattern on the finished base, rest the barrel in the saddle, and check the center height on both ends. Make necessary correction before you glue the barrel to the pattern.

You can make the clamp screw boss from scrap and glue it to the correct place on the barrel. Its flat surface is parallel to the parting line and it is tapered slightly for draft.

Round off the outside corners, form a small fillet on the inside corners, and sand smooth all over.

To make it easier to bed the pattern, it will help to mark the parting line on the ends of the prints and along the surface of the barrel.

Seal with two coats of shellac or varnish.

THE BAKED SAND CORE

It would be impossible to drive a steel core out of this casting, so a baked sand core must be used to provide the rough bore in the barrel.

Wheat flour and molasses water are used for a binder, with clean sharp silica sand. Clay bonded sand would be too hard to get out of the casting.

The basic formula is; 20 parts of sand to 1 part flour, tempered with 1 part molasses in 10 parts of water.

You are likely to have problems with getting a good bond with ordinary bread flour, although if you increase the proportion of flour it will work. Wheat paste that is sold for hanging wall paper works much better.

If you have trouble with the bond, throw the batch away and mix another with more flour. Keep notes on your mix for future use.

The sand and flour are mixed while dry, and the mix is tempered with the molasses water just as you do molding sand.

THE CORE BOX AND CORE PLATE

The core will be 6-112" long and 5/8" in diameter. A core box is used to form the core, and it is baked on a core plate in the kitchen oven.

It is easy to bore a hole through the length of the box if you cut a groove in both halves to guide the point of the drill bit. The groove functions as a pilot, on the same principle as the step drilling technique.

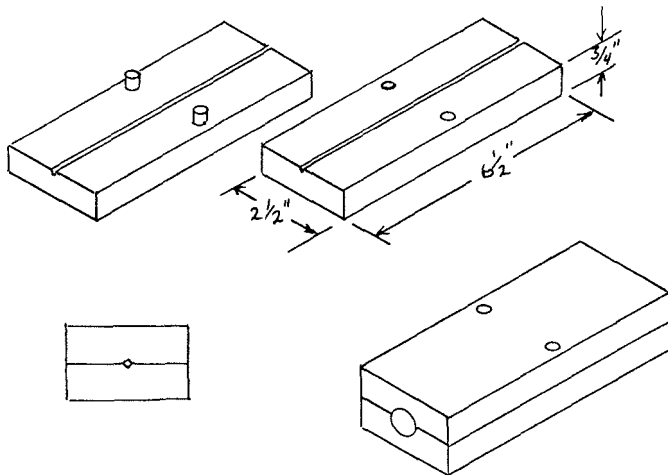

The dowel pins which align the two halves are installed by clamping both halves together and drilling two holes right through both members. Glue short dowels in one member.

With the box clamped together, mark the center of both ends, separate the halves, and cut a groove down the center. The groove can be cut with a saw or a straight edge and a knife.

With the halves reassembled, bore a 5/8" hole through the length of the box. A spade bit in the electric hand drill will work fine. Drill from both ends if the bit is not long enough to reach. If the pilot groove is true, a half hole will be in each member.

Fill any flaws, sand smooth, and seal with lacquer or varnish.

If the core were to be baked on a flat sheet it would not stay round. The box member without the dowels will provide the pattern for the aluminum core plate. Simply ram it up, gate it near the center on one side, and pour. A simple casting that requires little to finish it.

The core must be well vented because the gas that is generated by the burning of the flour and molasses will spoil the casting if it is forced to vent through the molten metal. I've found it impossible to push a vent wire through such a core, so I bed the wire as I fill the box, pulling it out later to leave the vent.

Two wires should be put in the core, one to be drawn out to leave the vent passage, and the other left in for a reinforcement

The core box is dusted with parting and the sand is tamped in firmly. I say "tamped", instead of rammed, because you want the core to be as porous as possible.

Lay the box flat, rap the male half, lift it off, and set the aluminum core plate in its place. Turn it over, rap the female half, pull out the vent wire, and lift the female half.

Place it in the kitchen oven and bake it at 350 degrees for about an hour. It should be a nice dark brown, but don't let it burn. It smells like molasses cookies when it's baking, so you won't get into trouble.

It's brick hard when it's done, but it will soften if you let it get damp. Don't put it in the mold until you are ready to pour.

MOLDING THE TAIL STOCK

The parting line has been planned to permit placing a baked sand core in the prints when the mold is opened. A green sand core will be formed by the pattern; it must be left on the face of the drag because its weight would separate it from the cope, and it would fall into the cavity.

A double roll is required, and we begin with a false drag, or an "Odd-side", which is dis-carded and re-made.

Prepare a blank drag and rap the pattern in up to the parting line. The green sand core will not be formed until you re-make the drag.

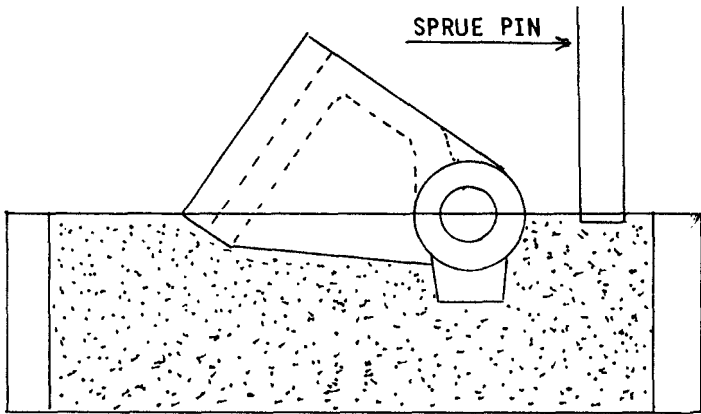

ODD-SIDE OR FALSE DRAG

Set a 1" sprue pin about 1-1/2" away from the barrel and ram up the cope. Remove the sprue pin roll over the entire mold, remove the false drag, and shake it out. Remake the drag, being especially careful to fill the cavity that forms the green sand core.

Roll over the second time, push a small dowel through the cope sand to rap the pattern, push the sprue pin back into the sprue hole, to leave a print, and open the mold.

The pattern should remain in the drag as you open the mold; rap it and remove it, push the vent wire through the core print area in both mold halves, cut the gate, set the core in the prints, close up the mold, and pour.

FINISHING THE TAIL STOCK CASTING

Having no box clamps, it isn't much of a job to finish the bottom of the casting. Dress it with a file and scrape it to rest solidly on the base casting. The top surface of the set over ways should not contact the casting.

The left side of the box is scraped to fit the set over ways; the right side is fit with a 1/4" square gib and two gib screws.

An elongated hole is cut in the bottom of the tail stock to allow set over motion. Two holes are tapped for the set over screws which bear against the clamp stud.

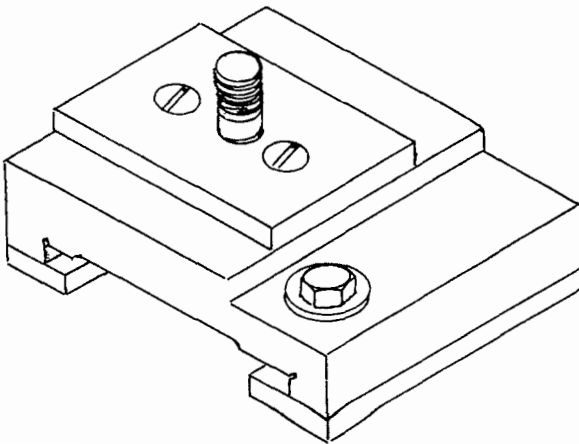
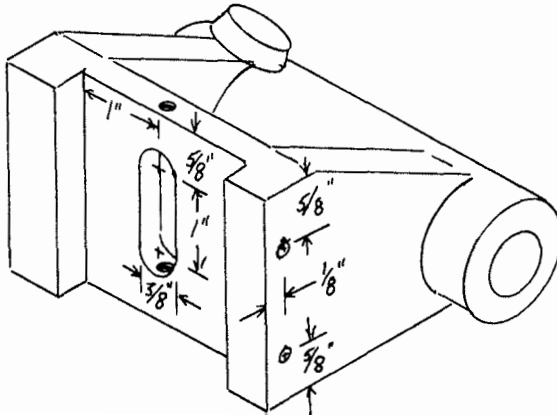

A 3/8"-16 hole stud is tapped in the base for the clamp stud.

The clamp stud can be a piece of 3/8"-16 threaded rod, but it is better to use a proper stud so that the set over screws can bear against an un-threaded portion.

The set over screws and the gib screws are #10-24, and they are fit with jamb nuts.

The whole is assembled with a nut and flat washer on the clamp stud. The gib screws are adjusted so that it will slide on the set over ways with slight drag. The set over screws are adjusted to bring the core hole to the center of the head stock spindle.

The tail stock is ready to bore.

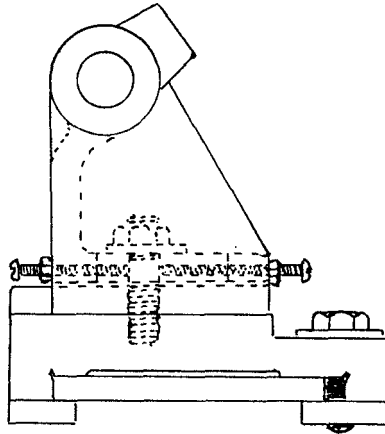

BORING THE TAIL STOCK

This will be a more pleasant chore than the head stock because you now have the power drive to the lead screw.

Remove the cross slide from the carriage and bolt a scrap of 1-1/2" x 2" angle iron to the cross slide ways. It will do no harm to drill and tap a 1/4"-20 hole in the center of the ways because the cross slide does not bear on it.

Dis-connect the apron from the carriage, remove the carriage, slide the tail stock on the bed ways, and slide the carriage up against the tail stock. Re-connect the apron, bolt or clamp the angle iron to the carriage, and the split nut will drive the tail stock along the ways.

The general procedure is the same as boring the head stock. The tail stock bore is $3/4"$. The first cut must be slightly over $5/8"$ so there will be clearance for the boring bar.

It will take one or more rough cuts to true up the bore; it will be best to dis-connect the power to the lead screw and feed the first cut by hand in case you run into trouble. Early cuts should be made with the lowest spindle speed, but a final light cut can be made at a higher speed.

Use a $3/4"$ shaft as a gauge standard. When the bore is finished, a $3/4"$ shaft should slip through the hole with very slight drag.

If you should end up over-sized, don't despair, you now have a lathe on which you can produce an over-sized tail stock ram.

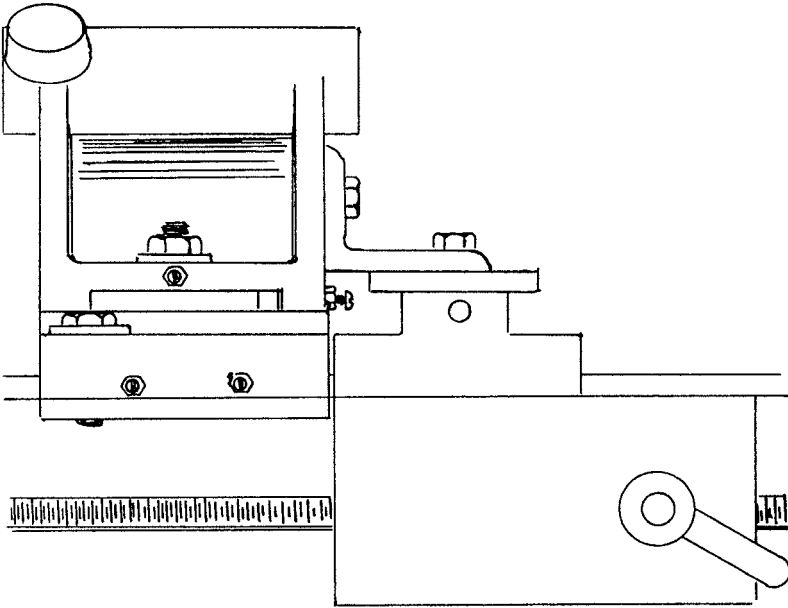

Since you supported the boring bar in the head stock, the tail stock bore will be on the same center. As the tail stock has traveled the bed while the cutter remained stationary, the bore will be parallel to the ways.

Progress will be fast now, for you can use the lathe to produce the remaining components.

CHAPTER X

FINISHING AND IMPROVING THE LATHE

As it now stands, the lathe seems of little use, but it is all you need to produce the remaining components.

A TEMPORARY SPINDLE AND RAM

A pair of 60 degree centers will be needed to produce the permanent spindle and tail stock ram.

Remove the boring bar from the head stock and install a length of 5/8" cold rolled round stock in its place. A set screw collar on each end will provide a thrust bearing.

You can use the compound slide to machine a 60 degree cone on the end of the shaft. That's all there is to making the temporary head stock spindle. The temporary tail stock ram is made in the same way, except it need not be as long.

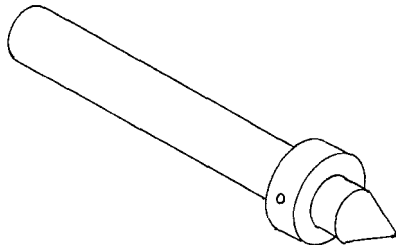

You can order a 60 degree center gauge from Sears if you don't find one locally. As the compound swivel base does not have graduations; you will have to estimate the angle, make a cut, and test with the gauge. When you have the correct setting, scratch a witness mark on the base.

The tail stock ram is about 7" long. The head stock spindle is about 9" long, so that there is enough shaft to take the face plate hub, and to carry the lead screw drive pulley.

The temporary tail stock ram is fit to the bore with a pair of 3/4"x 5/8" split pulley bushings. The set screw collar will provide thrust support.

A FACE PLATE AND CLAMP DOG

In order to do work between centers, you will need a plate to drive the work and a dog to clamp it.

You can use the lathe to produce the pattern for the face plate casting. A threaded shaft adapter, available at most hardware stores, will serve as an arbor to hold the pattern as you true it up in the lathe.

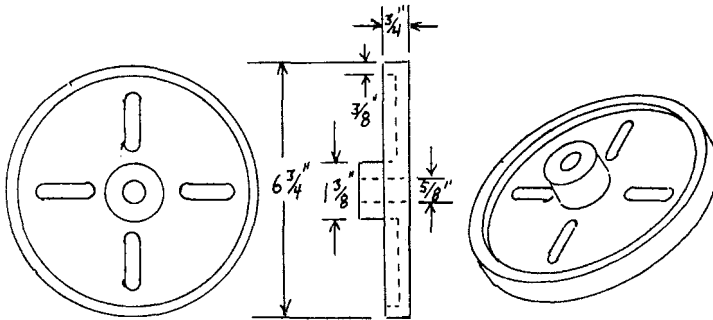

Jig saw the pattern from $\frac{3}{4}$ " plywood, glue the hub in the center, bore a $\frac{5}{16}$ " hole, slip in a $\frac{5}{16}$ " x $\frac{1}{2}$ " bushing, mount it on the lathe spindle with the threaded shaft adapter, and machine it to size and shape.

The section thickness is $\frac{3}{8}$ " all over. The slots are $\frac{5}{16}$ " x 2" on the face and $\frac{3}{16}$ " x $2\frac{1}{3}$ " on the back. The parting line is on the face of the pattern.

It is cast on a $\frac{5}{16}$ " steel arbor by the same method you used for the split nut casting, except that the arbor will be driven out to leave a $\frac{5}{8}$ " bore. Gate the mold at any point around the rim. Pour rapidly.

If the pattern is well drafted, especially in the slots, and finished smooth, it will only be necessary to cut off the gate, install a $\frac{5}{16}$ " set screw in the hub, and mount it on the lathe spindle to true it up and face it off.

Facing off the plate will give you the first test of the lathes accuracy. If there has been an error in mounting the cross slide it will show up here. You can correct by re-scraping the front box way to bring the cross slide ways to exact right angle to the bed ways.

I priced a simple 2" clamp dog at \$36.95 in a popular tool catalog. I kept my money and made one out of the remaining portion of 5/8" square key stock that was used to make the boring bar gauge tool.

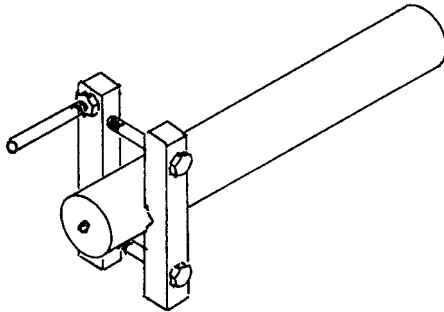
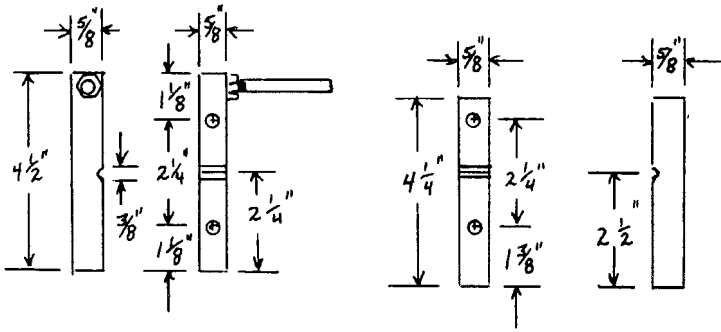

The drive pin is a 5/16" x 2-1/2" bolt with the head cut off. Tap the three holes in the longer bar, and enlarge the two holes in the short bar to 5/16". The difference in length and the hole spacing is a rough attempt at balancing the dog. It works very well except at high speeds. It will take some experimenting to perfect it.

TEST FOR PARALLELISM

The second test for accuracy is to determine if the centers will carry the work parallel to the bed ways.

Mount a length of 1" steel stock between the centers and true it up with a left hand turning tool in the tool post. This same piece of stock will serve for the tail stock ram, so there is no waste.

Measure the diameter on both ends to see if the shaft is tapered. You can do it with a calipers and a feeler gauge, or use a micrometer if you have one.

If the tail stock end is smaller than the head stock end, adjust the set over screws to move the tail center to the rear by 1/2 the difference in the end diameters of the shaft. A full turn of the set over screw will move the center about .042", so only a fraction of a turn should be needed. After two or three tests, followed by a new cut, you will be able to turn a shaft to the same diameter for its entire length. This operation will have to be repeated when the permanent tail stock ram is installed, so don't put a witness mark on the base yet.

Obviously, if the test proves the tail stock end to be larger, the set over adjustment is reversed.

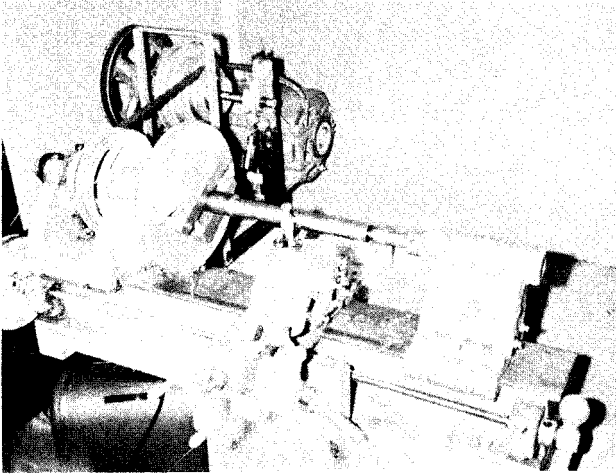

TURNING THE TEST SHAFT ON THE TEMPORARY CENTERS

Now it remains only to make the permanent spindle and the permanent tail stock ram, and your lathe is complete, You have the means to make what ever you need to match this machine against any commercially made lathe that you could afford to buy. I wouldn't sell mine for \$1000.00, would you?

THE TAIL STOCK RAM

While you could produce a #1 morse taper lathe center on the lathe, they are so in-expensive that I ordered one from Sears tool catalog. At the same time, I ordered a threaded arbor with a #1 morse taper shank and a 1/2" chuck to fit the arbor. There are several items in the catalog that are in-expensive and highly useful; including a set of 1/4" formed tool bits, small forged boring bars, a 60 degree center gauge, center drills, etc. . If you are going to use a hollow spindle on the head stock, you should order two #1 morse taper lathe centers.

You can bore a #1 morse taper socket in the tail stock ram, and you could not buy one any where, so that should be the next order of work.

A 5/16" hole through the center of the ram is needed to start the morse taper bore and it is also the tap size for the 318"-16 threads for the ram feed screw.

To begin; center drill a piece of steel stock 4" long, and larger than 314". Reduce it to 3/4", or what ever the exact bore in the tail stock turned out to be.

The secret to drilling through the length of a bar, is to rotate the work as you drill. Standard jobber length drill bits not being long enough to reach all the way, you will need to drill from both ends towards the center.

When you have machined the stock to the correct diameter, remove the tail stock and replace it with one of the boring bar supports with a 3/4" pillow block to support the end of the ram. Install a set screw collar to hold the ram against the live center, and drive the ram with the clamp dog.

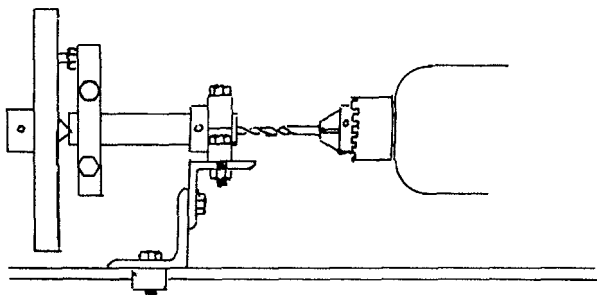

Using an electric hand drill with a 1/8" bit, drill a pilot hole 2" deep in the end of the ram. The lathe spindle should be turning at the slowest speed as you feed the bit, which is spinning in the opposite direction. If the bit has an accurate point, it will remain on center.

Remove the ram and set it up to drill from the other end. Feed very carefully as you near the center because there is danger of breaking the bit when it cuts through.

Enlarge one end to 5/16" by steps, as deep as you can reach, but don't enlarge the other end now. The original center must remain for the boring operation.

BORING THE MORSE TAPER SOCKET

A standard morse taper shank measures 2-1/8" long, .369" at the small end, and .475" at the large end. The taper is .5986" per foot. You have no way to pre-adjust the machine to do this work, but you can use any #1 morse taper shank accessory as a gauge to test the bore as you make trial cuts and adjustments. Since a number of cuts must be made before the bore comes to size, you will have found the right setting before the finishing cuts are made.

If the pillow block that supports the end of the ram is set over to the rear of the spindle center, a tapered hole will be bored by a 1/4" forged boring bar held in the tool post. It will be larger at the mouth.

Since there is no reference point to begin with, you can only make a crude estimate on the first set up. When you have made two or three cuts, wipe the test shank with the prussian blue and try it in the bore to determine the correct way to set over the pillow block. Test after each cut until you have a setting that matches the bore to the test shank. Mark the point 2-1/8" from the small diameter of the shank so that you don't bore over size.

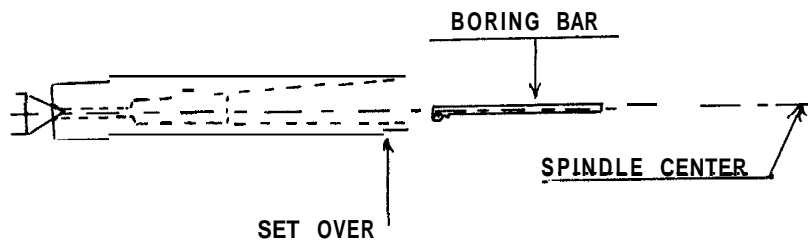

Of course, you must blow out the bore before each test, and re-blue the test shank each time. Don't try to test while the spindle is turning, it will ruin the shank. I used my threaded arbor with the morse taper shank because the threaded portion makes a good hand hold.

When you have finished the morse taper socket, turn the piece end for end and enlarge the other end to $5/16"$. Tap the hole $3/8"-16$ as deep as the tap will go. If it is not long enough to reach to the morse taper socket, you can enlarge the remaining portion to $3/8"$ by drilling from the taper socket end.

With a hack saw and a three cornered file, cut a key way along the length of the ram, about $1/16"$ wide and $1/16"$ deep.

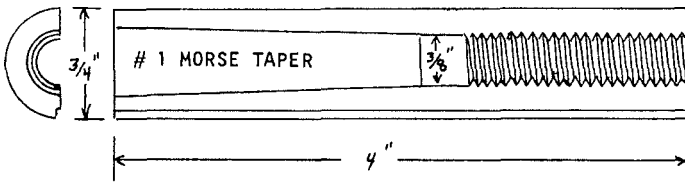

CUT AWAY VIEW OF RAM

THE RAM FEED SCREW

The threaded portion is $2"$ long with a $5/16"$ stub on the end. The straight portion is $1/4"$ diameter, and it is fit with a $2"$ ball handle to turn the screw.

It will be easiest if you mount a length of $1/2"$ steel stock between centers, reduce it to slightly less than $3/8"$ in diameter, cut the threads with a die while holding the work in a vise, and re-mount between centers to finish.

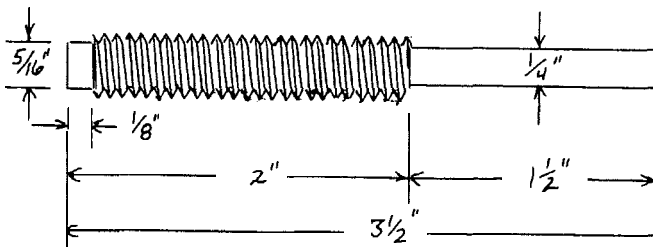

The stub on the end of the feed screw is meant to contact the end of the taper shank when the ram is fully drawn into the bore, to unseat the shank from the socket.

THE END BELL

Cast a 1-1/2" diameter round bar of aluminum, about 10" long, to provide the turning stock for the end bell. You need only a small portion of it, but the remainder is going to find plenty of use now that you have a lathe.

Square off the ends, center drill it and mount it between centers, and machine the end bell.

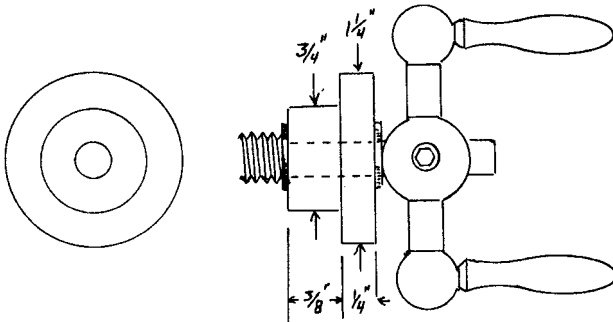

A 3/16" flat washer is reamed to fit the 1/4" shank of the screw, to provide a thrust bearing against the end bell. A 2" ball handle is locked to the shank with a set screw, and the end bell is fastened to the barrel of the tail stock with two #8-32 screws.

The shouldered portion of the end bell slips into the tail stock bore, and an 8-32 hole is tapped on each side of the barrel to accept the retaining screws.

THE CLAMP SCREW

Carefully drill a 5/16" hole through the center of the clamp screw boss on the barrel of the tail stock. A line drawn through the center of the clamp screw hole should intersect the center of the tail stock bore. Tap the hole for 3/8"-16.

The 1/16" key way that was cut in the ram, follows a key on the lock to prevent the ram from turning when the screw is turned. Form the key on the lock with a file.

The lock is bearing surface for the clamp screw, to prevent it from damaging the ram. It does not require a great deal of pressure to lock the ram.

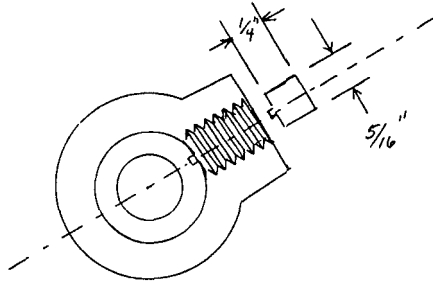

CUT AWAY VIEW OF CLAMP LOCK

The lock is followed by a 3/8"-16 x 3/4" cap screw to complete the tail stock.

Now you can turn another test bar between the centers to test for parallelism. It will be best to wait until you have installed the permanent head stock spindle before you make a witness mark on the base.

THE HEAD STOCK SPINDLE

There are a number of styles to choose from; you are equipped to make any of them, and it's not a bad idea to make more than one type for different purposes.

Since you don't have a chuck in the early development of your metal shop, you can quickly turn out a spindle for a special job. Cast the work right on the special spindle and install it in the lathe for machining. There is only time and scrap metal involved, your range of capability is not limited by the size of your pocket book.

These are only a few of the possibilities. They are all simple turning jobs, complete dimensions can be taken from your lathe, so there is no need for detailed discussion.

The procedure for those with a through hole and taper socket is the same as for the tail stock ram.

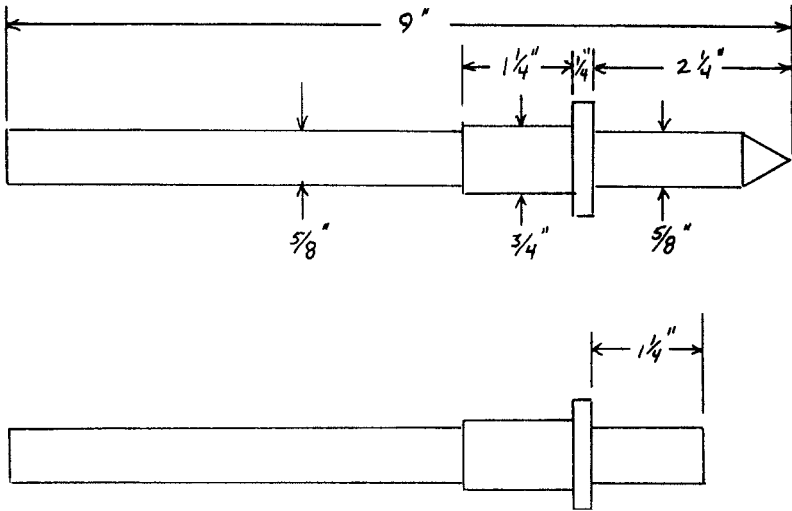

It being a simple matter to change spindles, a cone nosed spindle and a blunt nosed spindle will serve a wide variety of jobs.

The spindle nose can be plain or threaded. With care, threads can be cut on the spindle nose with a die, since you do not yet have change gears for thread cutting.

The blunt nosed style can be drilled and bored with a morse taper socket.

A separate spindle, with a face plate or drive plate cast right on its end can be prepared.

Special holding fixtures can be cast in aluminum on the nose of the spindle, and machined to accept the work to be done on the lathe.

Design your own spindle, and incorporate features in it that suit your purpose. You are limited only by your own imagination; if you are short of cash, don't spend it on a four jaw chuck, make a holding fixture out of junk.

PERMANENT BEARINGS FOR THE HEAD STOCK

The temporary bearings in the head stock have outlived their usefulness, it is time to replace them with something better.

Of course the head stock could have been designed for tapered roller bearings, but I felt that a split saddle is a better approach with limited equipment.

A bronze sleeve bearing with an integral thrust collar is the easiest to use. They are available, finished to size, from industrial bearing supply companies. Those I was able to find were not long enough to reach through the saddle bore on the large end, so I added a short length of straight bushing to provide full support. A 1" x 3/4" is needed for the in-board end, and a 3/4" x 5/8" for the outboard end. A 1" x 3/4" split steel pulley bushing is used in the out-board end.

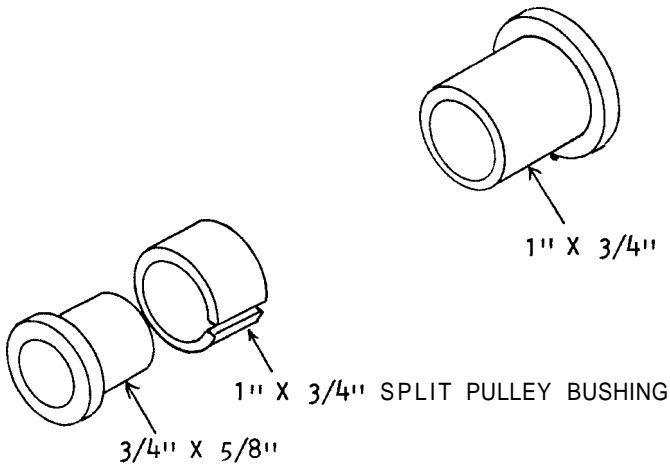

Drill a 1/4" hole in each cap, and a 1/8" hole through the bushing, so you can oil the bearings. Stuff a little bit of cotton waste in the hole to absorb the oil and keep grit out of the bearings.

The bearings can be split with a fine coping saw blade and adjusted for wear by removing shims from the caps. As a good practice project, use your lathe to machine a set of replacement bushings from brass stock.

CONCLUSION

By now your imagination has provided you with enough projects to keep you busy for some time to come. I hope you are pleased with your lathe.

This manual is meant to be an answer to the man who wants to spend his spare time in metal working, not his money.

It has taken over 25 years to develop this series of projects. The methods, while old fashioned, are in no way un-professional. You can do work with these simple hand skills that will amaze you. In our generation, we have become dependent on a technology that we sometimes can't afford; it keeps us from doing things because we can't buy what we need to do it with. By building your own machines from scrap, there is hardly a limit to what you can do.

Methods for making back gears and change gears, and other accessories, will be presented in Book 6. In the mean time, design your own accessories and develop your skill. Remember that; while the lathe has an apparent swing of 7" over the ways, it will not be capable of such heavy work until the back gears are added. It can easily produce a 6-3/4" face plate in aluminum, but it would be severely strained to do the same job on one of cast steel.

Keep safety in mind always. There are serious dangers in foundry and machine work; men get crippled and killed, for simple mistakes and carelessness. Open belts and a spinning clamp dog are a more serious threat than you may imagine. Be a fanatic about safety, don't be a victim.

Do some supplementary reading in the oldest manuals you can find. Those methods that are considered obsolete in modern practice, have great value in the home shop. A manual like South Bends "How To Run A Lathe", will be a valuable help in using the lathe. "The Complete Handbook Of Sand Casting", by C. W. Ammen, will answer your needs for foundry information.

Your most valuable asset is your scrap pile and your imagination. Put them to work together.

THE END

INDEX

- Baked sand core . . .106, 107, 108
Ball handles 43
Bearing blue 11
Bearing caps 83
Bearings. bronze 125
Bearing. pillow block . . . 55, 56
Bearings. thrust 125
Blank cope 15
Blank drag 15
Boring bar 89
Boring bar support 86
Boring cutter 89. 90
Boring gauge 92, 94, 95
Boring theory 85
Box slide 29
Bronze bushings 94
Bronze sleeve bearings . . . 125
Bushings. bronze 94
Bushings. split steel 96
Calipers 93
Center gauge 115
Clamp dog 117
Concentric drilling 13
Coping down 29
Core. baked sand- 106, 108, 109
Core. green sand 15. 111
Core. steel 38.47. 60
Core box 109
Core mix 109
Core plate 109
Core print 65
Dead flat 12
Double role 15. 23
Drilling 13
End bell 122
Face plate 116
False cope 15.29. 47
False drag 15
Feeler gauge 93, 94
File. lathe 13
File. safe edge 13. 30
Filleting 21
Filletts 14
Gauge boring 92.94. 95
Gauge center 115
Gauge feeler 93, 94
Gauge. setup 91
Gib 29. 30
Gib screws 32
Green sand core 15, 111
Hand scraping . . . 11.25.30. 33
Indicator color 11
Lathe file 13
Melting metal 16
Molding 14. 15. 16
Morse taper 119
Morse taper socket 120
Odd side 111
Pads. wear 28.29. 30
Parallelism 117. 123
Pattern making 14
Pillow block bearings . . . 58. 86
Pilot drill 13
Prussian blue 11
Safe edge file 13. 30
Scraping. hand . . 11, 25, 30, 33
Set over screws 112
Set over ways 104
Set up gauge 91
Shims 31.32. 83
Shrink cavity 78
Split nut 59

Split nut detent	68	Temporary apron	84, 85
Split steel bushing	96	Tapping	13
.	38, 47, 60	Three cornered scraper	11
Step drilling	13	Tool post	51
Test standard	11	Wear pads	28, 29, 30
		Whip lathe	7

BUILD YOUR OWN METAL WORKING SHOP FROM SCRAP

- Book 1. The Charcoal Foundry
- Book 2. The Metal Lathe
- Book 3. The Metal Shaper
- Book 4. The Milling Machine
- Book 5. The Drill Press
- Book 6. The Dividing Head & Deluxe Accessories
- Book 7. Designing & Building The Sheet Metal Brake

The "Metal Shop From Scrap" series, is a group of progressive projects planned around home made castings in aluminum and pot metal.

Beginning with ordinary hand tools and improvised methods, you will gradually acquire a complete set of machines for metal working, and the skill and knowledge to use them.

The machines are of fundamental design, and the sequence of operations is planned to use the machines to produce their own parts without ever having to look to outside custom work in machining the parts.

A practical approach for the individual who wants to build a shop and develop skill in metal working.