

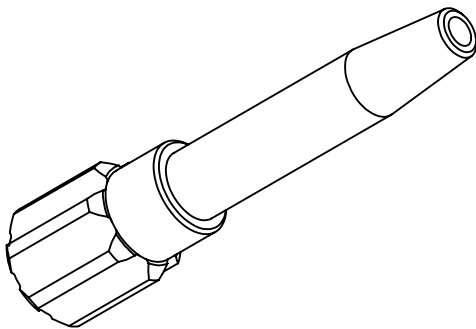
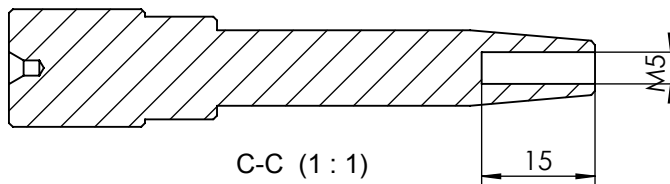
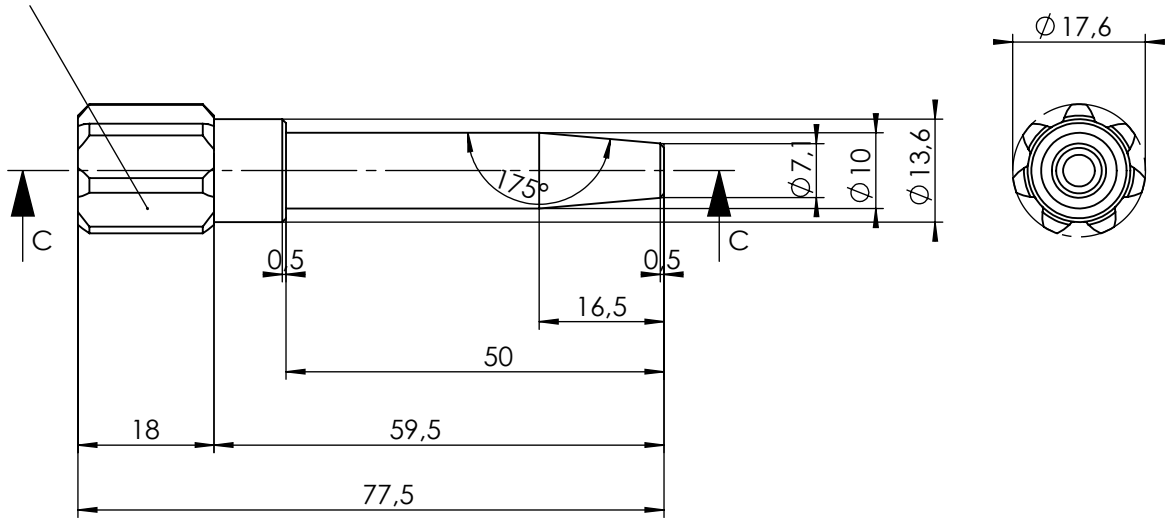

Tolerance prostih mer:

<100 = $\pm 0,20$ >100 - 300 = $\pm 0,30$ >300 = $\pm 0,50$

Površinska obd.:

DIN5480
z=7
m=2

Poz.	Šifra mat.SAP	Naziv in mere			Kosov	Material	Masa surovca(kg)	
	 Tajgo d.o.o. Kidričeva 24, SI-3000 Celje	Zasnoval	Miha		Spremembe	(5)		
		Risal				(4)		
		Pregledal				(3)		
			Datum	Podpis		(2)		
		Merilo	Format	Obdelava		(1)		
		A4				Datum	Bilo je	Podpis
	Del	Gred elektromotorja			Masa (kg)	Št.risbe SAP	Verzija	
Izmera	(mm)	Izdelek	Sklop	Št.mat. SAP	Projekt.št.(stara št.)			
Tolerance								