

CNC Spindle motor



远东机电

Eastern Electromechanics Industrial Limited

CNC Spindle motor

Address: Chang Ping, Dongguan, Guangdong, China

Telephone: 86-769-85612586

Email: eastern_mechanic@hotmail.com

Contact Person: Mr. Jason Yang

Showroom: <http://easternmechanic.en.made-in-china.com>

1. CNC Air Cooling Spindle (MRZ Series)



Origin	China	Trademark	MT
Serial/Model NO.	MRZ Series	Standard	CCC / CE
Type	Machine Tool&Accessories		

Trade Terms

HS Code	84669300		
----------------	----------	--	--

Availability

Production Capacity	2500PCS/Month	Packing	Standard Export Wooden Case Package
----------------------------	---------------	----------------	-------------------------------------

Description

Simple introduction of our CNC spindle motor:

1. All with 1-year quality guarrantee; (bearings: 6-month; Spindle: 12-month)
2. Competitvie price
3. Various kinds for clients: ATC spindle Water cooling spindle Belt-driven spindle
4. Most of spindles with stock.

DRAWING

Air cooling cnc high speed spindle motor

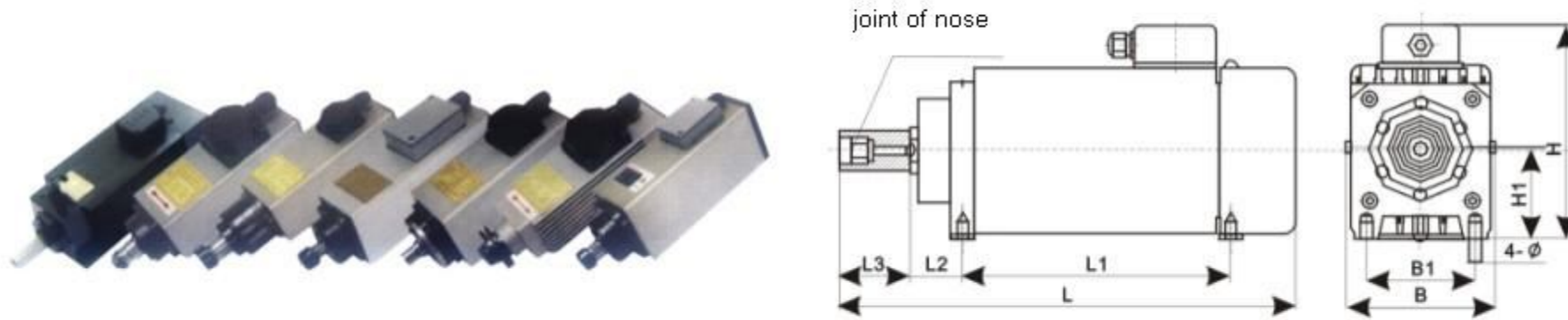

Product Table

Type	Speed	Torque (N. m)	KW	V	A	HZ	Dimensions (min)									joint of nose	lub	Cool	kg	Bearings type (NSK)
							L	L3	L2	L1	B	B1	H	H1	4-					
MRZ350	12000	0.2	0.35	380 220	0.8 2.0	200	250	25	50	80	69	22	95	28	M6	ER11-ø3.175 ø7	Grease	Air	3	2*7004CP5 1*7002CP5
MRZ750	18000	0.4	0.75	380 220	2.0 3.6	300	250	25	50	80	69	22	95	28	M6	ER16-ø3.175 ø10			3	2*7004CP4 1*7002CP4
MRZ1100	24000	0.6	1.1	220	3.3	400	260	27	53	120	70	38	115	42	M6	ER16-ø3.175 ø10			5	2*7005CP4 1*7002CP4
MRZ1500	24000	0.8	1.5	220	6.5	400	305	27	53	120	70	38	115	42	M6	ER20-ø3.175 ø13			5	2*7005CP4 1*7002CP4
MRZ2200	24000	1.2	2.2	380 220	3.6 5.6	300	282	27	55	150	92	52	145	53	M6	ER20-ø3.175 ø13			8.1	2*7005CP4 1*7204CP4
MRZ3000	18000	1.6	3	380	7.9	300	364	27	55	150	92	52	143	53	M8	ER25-ø3.175 ø16			13	2*7007CP4 1*7204CP4
MRZ4500	18000	2.4	4.5	380	9.5	300	326	35	67	180	106	70	157	60	M8	ER25-ø3.175 ø16			13	2*7007CP4 1*7204CP4

2. CNC Spindle Cutting / Drilling Motor (MRH SERIES)



Origin	China	Trademark	MT
Serial/Model NO.	MRH SERIES	Standard	CCC / CE
Type	Metal Cutting Machine		

Trade Terms

HS Code	84669300		
----------------	----------	--	--

Availability

Production Capacity	2500PCS/Month	Packing	Standard Export Wooden Case Package
----------------------------	---------------	----------------	-------------------------------------

Description

- Simple introduction of our CNC spindle motor:
- 1 all models with high quality :bearing with 6-month quality guarantee ; the spindle with 12-month guarantee
 - 2 all models with sock
 - 3 competitive price
 - 4 successfully used for CNC Milling & cutting ,special made for drilling PCB ,Acrylic, aluminum etc

DRAWING

Permanent-torque high speed cnc router spindle

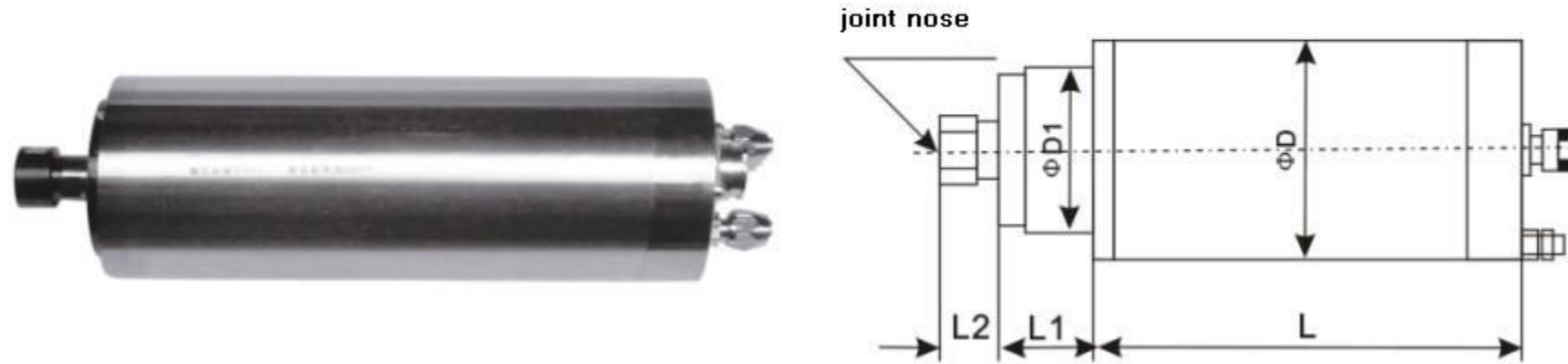

Product Table

spindle type	speed (r/min)	spindle motor				size						cooling	Lub	Bearings type	kg
		rated power KW	voltage V	current A	frequency HZ	D	D1	Jointofnose	L	L1	L2				
MRHZ90	40000	0.095	36	1.4	667	48	40	∅ 3.175	115	6	23	self-cooling	Lubrication	1×C36018/1×C36100	1.8
MRH300	60000	0.3	75	1.5	1000	48	42	∅ 3.175	124	6	23	water-cooling		NSK:1×7001CP5/C36018	2
MRHZ400	40000	0.4	110	1.2	667	58	49	∅ 3.175-∅ 6	172	6	18	self-cooling		NSK:1×7002CP4/1×7001CP4	2.5
MRHZ800	24000	0.8	220	2.5	400	60	56	∅ 3.175-∅ 6	203	10	19	self-cooling		NSK:1×7002CP4/1×7001CP4	3.5
MRH800	40000 24000	0.8	220	2.5	667 400	65	48	∅ 3.175-∅ 6	172	6	18	water-cooling		NSK:1×7002CP4/1×7001CP4	3.5
MRH800I	40000 24000	0.8	220	2.5	667 400	62	58	∅ 3.175-∅ 7	197	12	17	water-cooling		NSK:1×7002CP4/1×7001CP4	3.5
MRH800II	40000 24000	0.8	220	2.5	667 400	58	58	∅ 3.175-∅ 7	209	12	15	water-cooling		NSK:1×7002CP4/1×7001CP4	4
MRH1000	24000	1	220	4	400	62	62	∅ 3.175-∅ 7	200		15	water-cooling		NSK:1×7002CP4/1×7001CP4	
MRH1200	40000	1.2	220	4	667	62	58	∅ 3.175-∅ 7	210	6	15	water-cooling		NSK:2×7002CP4/1×7001CP4	4.5
MRH1500	40000	1.5	220	5	667	80	60	∅ 3.175-∅ 7	185	10	20	water-cooling		NSK:1×7002CP4/1×7001CP4	5
MRH1500I	24000	1.5	220	4.7	400	80	60	∅ 3.175-∅ 10	212	13	31	water-cooling		NSK:2×7004CP4/2×7001CP4	7.5
MRH1500II	24000	1.5	220	4.7	400	85	65	∅ 3.175-∅ 10	212	13	31	water-cooling		NSK:2×7005CP4/2×7001CP4	7.5
MRH2200	24000	2.2	220	6	400	80	60	∅ 3.175-∅ 13	277	13	22	water-cooling		NSK:2×7005CP4/2×7002CP4	10
MRH2200I	24000	2.2	220 380	6	400	100	79	∅ 3.175-∅ 13	248	18	22	water-cooling		NSK:2×7005CP5/2×7002CP5	9

CNC Spindle motor

MRH3000	24000	3	380	6	400	105	84	∅ 3.175-∅ 13	250	18	25	water-cooling	NSK:2×7005CP5/2×7004CP5	12
MRH3500	24000	3.5	380	8	400	105	84	∅ 3.175-∅ 13	290	18	25	water-cooling	NSK:2×7007CP5/2×7205CP5	15
MRH4500	24000	4.5	380	8	400	125	84	∅ 3.175-∅ 16	298	13	28	water-cooling	NSK:2×7007CP5/2×7205CP5	15
MRH5500	24000	5.5	380	10.5	400	125	98	∅ 3.175-∅ 16	325	54	36	water-cooling	NSK:2×7009CP5/2×7206CP5	28
MRH7500	18000	7.5	380	15	300	150	109	∅ 3.175-∅ 20	343	48	45	water-cooling	NSK:2×7009CP5/2×7205CP5	40

3. High Speed CNC milling/Cutting Spindle Motor (MRD series)



Origin	China	Trademark	MT
Serial/Model NO.	MRD series	Standard	CCC / CE
Type	Machine Tool&Accessories		

Trade Terms

HS Code	84669300		
----------------	----------	--	--

Availability

Production Capacity	2500PCS/Month	Packing	Standard Export Wooden Case Package
----------------------------	---------------	----------------	-------------------------------------

Description

Simple introduction of our CNC Milling / Cutting spindle motor:

- 1 all models with high quality :bearing with 6-month quality guarantee ; the spindle with 12-month guarantee
- 2 all models with sock
- 3 competitive price
- 4 successfully used for CNC Milling & cutting

DRAWING

Permanent-frequency high speed cnc router spindle

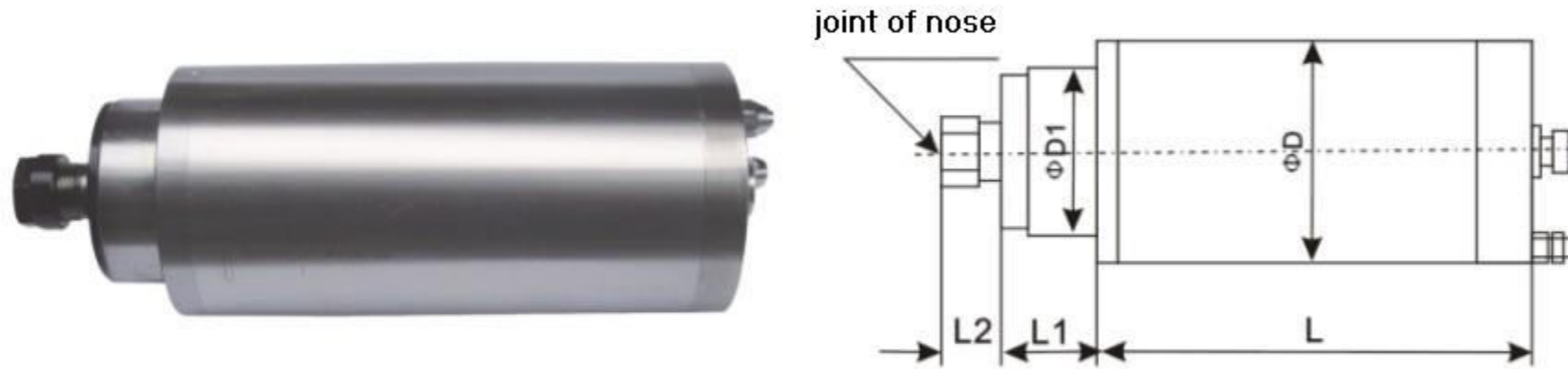

Product Table

Type	Permanent Power spindle						Dimensions (mm)						lub	Cool	Bearings type (NSK)	kg
	Speed (r/min)	KW	NM	V	A	HZ	D	D1	joint of nose	L	L1	L2				
MRD1500	12000/ 24000	1.5	2.38/ 1.19	220	5	400	80	68	ER20	230	13	15	Lub	water	2*7005CP4 2*7004CP4	9
MRD2200-1	12000	2.2	3.5	220	6	400	80	68	ER20	277	13	15			2*7005CP4 2*7004CP4	13
MRD2200-2	24000	2.2	3.5	380	5.9	400	105	78	ER20	262	21	29			2*7006CP4 2*7004CP4	16
MRD4000	21000	4	3.64	380	9.1	700	120	98	ER25	345	38	32			2*7007CP4 2*7005CP4	22

CNC Spindle motor

MRD5000	12000	5	5.31	380	10	400	125	92	ER25	300	15	20		2*7007CP4 2*7005CP4	24
MRD7500	18000	7.5	7.96	380	16.5	600	140	98	ER32	415	38	39		2*7007CP4 2*7005CP4	48

4. CNC engraving / milling Spindle Motor (MT Series)



Origin	China	Trademark	MT
Serial/Model NO.	MT Series	Standard	CCC / CE
Type	Metal Cutting Machine		

Trade Terms

HS Code	84669300		
----------------	----------	--	--

Availability

Production Capacity	2500PCS/Month	Packing	Standard Export Wooden Case Package
----------------------------	---------------	----------------	-------------------------------------

Description

Simple introduction of our CNC Engraving-spindle motor:

1. special made for engraving
2. usually with stock
3. competitive price

NOTE:

The MT series cnc water cooling spindle motors belongs to OEM type which made according to different client's request not standard ; and its MOQ:4pcs ;

CNC Spindle motor

DRAWING

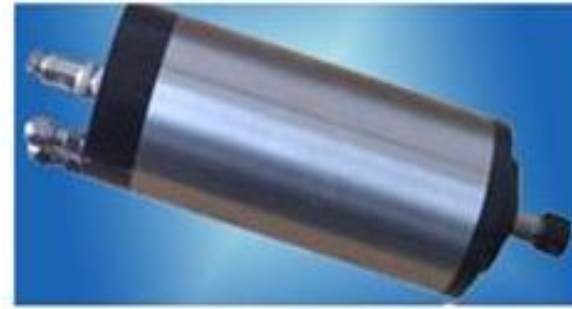
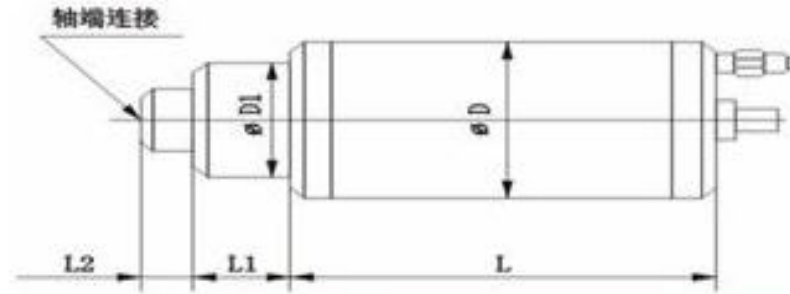

Product Table

item code	speed	motor				lubrication	seal	cooling	Tool collet	outer size					bearing type	character				
		Motor								grease	seal	water	Dimension(mm)					Bearing SD type		
		Speed (r/min)	KW	V	A								Hz	D			D1		L	L1
MT-37A	24000	3.7	220	6.4	400	grease	Dynamic Performa	water	ER25	110	80	271	38	12	7007C/P4X2 7005C/P4X1	constant torque				
MT-25	9000	2.5	380	5.3	150	grease	Dynamic Performa	water	ER25	120	80	290	31	10	7008C/P4X2 7006C/P4X1	constant torque				
MT-45-30A	30000	4.5	350	12	600	grease	air	water	BT30	140	95	264	36	16	7006C/P4 X2 7005C/P4X2	manual bar				
MT-55	9000 / 14000	5.5	380	12	450/ 700	grease	air	water	ER32	140	115	302	91	43	B7010C/P4 X2 B7208C/P4X2	constant torque				
MT-45-30B	24000	4.5	293	10.4	400	grease	air	water	ER20	150	94	235	49	34	7006C/P4X2 7005C/P4X2	constant torque				
MT-75A	18000	7.5	380	12	300	grease	air	water	ER32	150	115	302	91	43	7008C/P4X2 7007C/P4X2	constant torque				
MT-75B	9000 / 18000	7.5	350	15.1	200	grease	air	water	ER32	170	125	280	24	35	7008C/P4 X2 7007C/P4X2	constant torque/manual				
MT-37B	3000/ 9000	3.7	220/38 0	12.5/ 11.3	100/ 300	grease	air	water	BT30	170	125	338	115	43	7013C/P4X2 7209C/P4X2	constant torque/manual				

MT-10	300/ 1500	10	310	22	11/ 55	grease	air	CNC water	Spindle motor BT40	200	170	465	56	20	7014C/P4X2 7209/P4X2	constant torque/manua
-------	--------------	----	-----	----	--------	--------	-----	--------------	-----------------------	-----	-----	-----	----	----	-------------------------	--------------------------

Note: 1)the bearing for the above quotation mainly domestic or ceramics bearing.
2)the price will be adjusted if need import bearings ;
3)the brand of import bearing : NSK ,FAG ,SKF etc;

5. CNC Turning-Spindle Motor (MCJ Serie)



Origin	China	Trademark	MT
Serial/Model NO.	MCJ serie	Standard	CCC / CE
Type	Metal Cutting Machine		

Trade Terms

HS Code	84669300		
----------------	----------	--	--

Availability

Production Capacity	2500PCS/Month	Packing	Standard Export Wooden Case Package
----------------------------	---------------	----------------	-------------------------------------

Description

Simple introduction of our CNC turning-spindle motor:

1. special made for turning
2. high quality & competitive price
3. MOQ:1pcs
4. usually with stock

CNC Spindle motor

DRAWING



Product Table

spindle	speed	outer size								Driven	Lub	Joint of Noze	
		D	D1	D2	L	L1	L2	N-ød1	ød2xL3			outer ring	inner hole
MCJ-120Z6	6000	120	125	140	194	25	62	4-ø6.6	ø11x6.5	Belt	Grease	ø32-ø3	7010C/P5 X2 7010C/P5X2
MCJ-140Z6	6000	140	160	178	305	72	123	6-ø9	ø14x9			ø63.5-ø45	7013AC/P5 X 2 7013AC/P5X2
MCJ-150Z4.5	4500	150	180	200	350	78	71	8-ø9	ø13.5x9			ø130-ø45	B7014AC/P4 X2 B7012C/P4X2
MCJ-160Z4.5	4500	160	187	206	350	77	70	8-ø9	ø14x9			ø95-ø56	7016C/P4 X3 7013C/P5X2
MCJ-170Z4.5	4500	170	205	200	271	70	147	6-ø11	ø17x10			A25T-ø6	7216C/P4DB X1 7216C/P4DBX1
MCJ-200Z4	4000	200	240	270	468	80	107	8-ø11	ø18x10			A26-ø5	7220CTA/P4X4 7213CTA/P4X2
MCJ-250Z3.3	3300	250	280	310	840	148	65	8-ø11	ø18x12			A11-ø100/ ∠1:20	NN3024ASK/P4 X1 nn3026ASK/P4X1
MCJ-300Z1	1000	300	350	400	300	95	150	8-ø18	ø26x18			A11-ø145/1:20	B7030AC/P5 X2 B7208AC/P5X2

6. CNC Belt-Driven Spindle Motor (MBT Series)



Origin	China	Trademark	MT
Serial/Model NO.	MBT series	Standard	CCC / CE
Type	Metal Cutting Machine		

Trade Terms

HS Code	84669300		
----------------	----------	--	--

Availability

Production Capacity	2500PCS/Month	Packing	Standard Export Wooden Case Package
----------------------------	---------------	----------------	-------------------------------------

Description

Simple introduction of our CNC Belt-driven spindle motor:

1. All belt-driven spindles are all Automatic tool change spindle
2. competitive price
- 3.

CNC Spindle motor

DRAWING

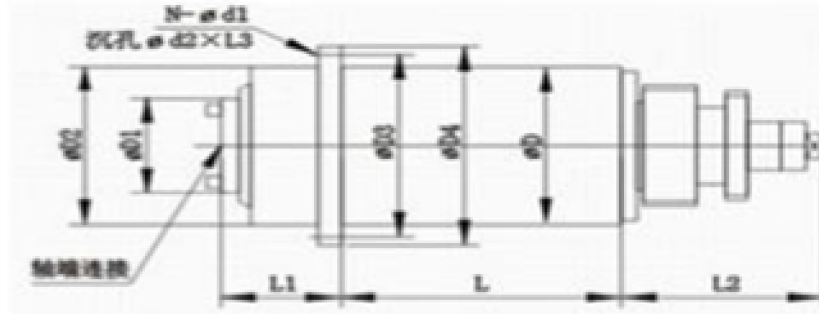

Product Table

Spingdle type	Speed (r/min)	Dimensions(mm)										Joint of Noze	Power	Bearings type	Characteristics
		D	D1	D2	D3	D4	L	L1	L2	N- φ d1	d2× φ L3				
MBT30	6000	90	35	90	105	122	105	80	90	6-Φ9	Φ15×8	BT30 tapered bore	2.5	B7008AC/P4X2 B7007AC/P4X2	Belt-type drive broach
MBT40	6000	120	76	120	145	165	156	145	123	6-Φ9	Φ15×8	BT40 tapered bore	5.5	B7011AC/P4X4 B7011AC/P5X2	
MBT40II	8000	120	78	130	146	165	165	128	134.5	6-Φ9	Φ14×8	BT40 tapered bore	5.5	7012C/P4X2 7010C/P4X2	
MBT30II	10000	120	69.823	120	144	177	240	100	200	6-Φ11	Φ17×11	BT30 tapered bore	5.5	B7010C/P4X3 B7009C/P4X2	
MBT40III	6000	140	88.8	140	164	187	245	135	212	8-Φ11	Φ17×11	BT40 tapered bore	7.5	B7014C/P4X4 B7012C/P4X2	
MBT40IV	8000	140	88.8	140	164	187	245	135	212	8-Φ11	Φ17×11	BT40 tapered bore	7.5	B7013C.T.P4SX3 B7011C.T.P4SX3	
MBT40V	8000	150	84	155	180	202	192	138	181.4	8-Φ11	Φ17×11	BT40 tapered bore	7.5	7014CTDB/P4 X2 7012CTDB/P4X2	
MBT50	3000	190	128.57	210	230	250	398	62	158	8-Φ9	Φ15×8	BT50 tapered bore	11	7021C/P4 X4 7018C/P4X2	
MSO50	1000	210	129	270	305	340	540	155	368	12-Φ13	Φ18×12	IS050	15	318216 /226 X2 226318214X2	

7. CNC Automatic tool change (ATC) Spindle (AMT Series)



Origin	China	Trademark	MT
Serial/Model NO.	AMT Series	Standard	CCC / CE
Type	Metal Cutting Machine		

Trade Terms

HS Code	84669300		
----------------	----------	--	--

Availability

Production Capacity	2500PCS/Month	Packing	Standard Export Wooden Case Package
----------------------------	---------------	----------------	-------------------------------------

Description

Simple introduction of our CNC ATC spindle motor:

1. the spindle's diameter bigger than 170mm with flange ; or without ;
2. we can accept OEM service once the quantity reach 10pcs
3. competitive price
4. MOQ:1pcs
5. usually there is no stock

CNC Spindle motor

DRAWING

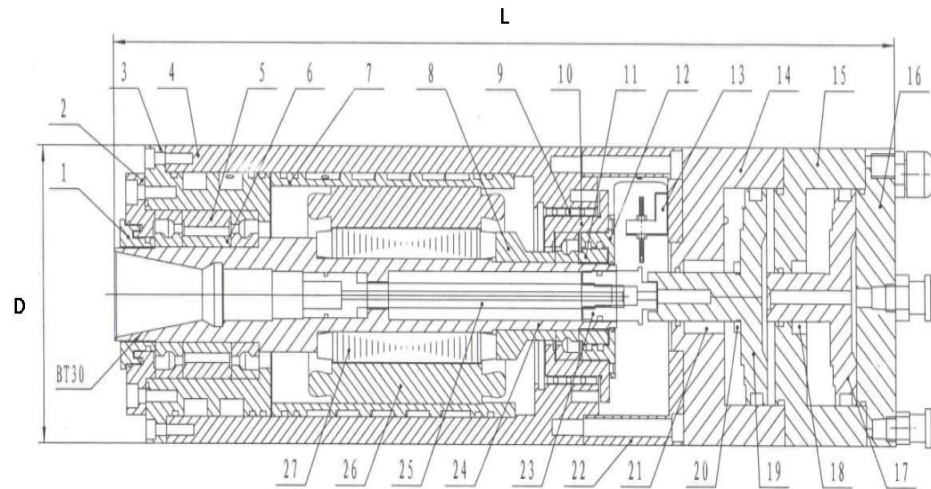

Product Table

spindle item	RPM	motor				outer dimensions		Torque (NM)	Lubrication	cool	sea l	Tool collet	Bearing (ceramics)	Type	character
		KW	V	A	Hz	D	L								
AMT-22	0-24000	2.2	220/380	9	800	110	417	Grease	water	Air	BT30	B7005C/P4X2 7003C/P4X1	Pneumatic Tool changer	With position sensor	
AMT-32	0-24000	3.2	220/380	9	800	110	417		water		BT30	B7007C/P4X2 7005C/P4X1			
AMT-37	0-24000	3.7	220/380	9	800	110	417		water		BT30	B7007C/P4X2 7005C/P4X2			
AMT-45	0-24000	4.5	220/380	16	800	120	454		water		BT30	B7007C/P4X2 7005C/P4X1			
AMT-50	3000-18000	5.0	220/380	12.5	600	120	454		water		BT30	7013C/P4X2 7011C/P4X2			
AMT-55	3000-18000	5.5	220/380	15	600	120	454		water		BT30	7008C/P4X2 7006C/P4X2			
AMT-75	2000-15000	7.5	220/380	17	750	150	520		water		BT40	7013C/P4X2 7011C/P4X2			
AMT-80	2000-15000	8.0	220/380	17	750	150	520		water		BT40	7013C/P4X2 7010C/P4X2 7212AC/P4X2			