

# A SPARK EROSION MACHINE

by C. R. Amsbury

NO DOUBT every model engineer has broken small, and sometimes not so small, taps and drills in components-with anything from a muffled grunt to a tantrum and throwing the bit through the workshop door-oh ! for a spark erosion machine !

A spark erosion machine works as the name implies, by creating numerous small sparks between an electrode and the workpiece. Each spark is a miniature explosion and blows away a small piece of the work and the electrode-as you will know if you've got a small screwdriver across a live mains plug at some time ! As the electrode is also worn away this must be expendable and by using suitable materials the electrode wear can be made considerably less than the workpiece; fortunately copper is a good general purpose material for most work, particularly steels. These machines have been with us for many years now and for those lucky enough to have access to one, usually at work, the broken tap problem is easily solved. However, all commercial machines are very expensive and most of them will do much more than the average model engineer requires. The one to be described is very simple and can be made by any model engineer with a little knowledge of electrics and the usual abilities with a small soldering iron.

The emphasis is on "small", as the rate of removal of material is dependent mainly on the current available; this model gets very slow when asked to handle an electrode more than about 1/8 in. square. It is intended mainly for removing broken drills and taps up to about 1/8 in. and making irregular shaped holes, either through or blind. The machine comprises three parts, a motorised head which carries the electrode, an electronic drive and power unit and an electrolyte tray and circulating system. The heart of the system, which "makes it", is the type of motor used. Most commercial machines use hydraulics; this uses a relatively new design called a stepping motor.

As its name indicates, the motor moves in discrete steps in response to electrical pulses and can then be virtually instantaneously stopped and reversed. The speed is constant and readily controllable by the frequency of the drive pulses. This motor is mounted on a simple bracket and the shaft is extended in the form of a leadscrew. This drives a small slide on which is mounted, via an insulating block, a small chuck carrying the electrode. To obtain a fast response and hence improve the cutting rate, all the moving parts should be as light as possible and backlash should be kept small.

This head is usually mounted vertically and if most model engineers are as short of space as I am this machine will not qualify for a permanent space on the bench. Consequently, when needed, I mount the head in the drilling machine and bolt the work tray to the table-one then has a convenient vertical adjustment also.

The drawings of the head are generally self-explanatory and it is very simple to make, the most important and difficult item being the coupling of the motor to the leadscrew. The leadscrew *must* run true when the motor is rotated and to this end the coupling has no grub screws; it should be a good fit on both shafts and held by a spot of Loctite.

The leadscrew thread is not critical and if 40 t.p.i. is used it can be lathe cut and cleaned up to size with a die. A small ball is used at the top of the motor shaft to control end-float and an anti-backlash nut can be incorporated in the larger motor version to advantage-the extra friction is not desirable with the small motor. The whole slide assembly must, of course, be free, but with no side shake. Two designs of head are shown; the larger one uses a larger, more powerful (and more expensive) motor, but both can be driven from the same electronic box. To take advantage of the larger electrodes this motor could handle, a bigger power supply would be required, but even without this it has some advantages in greater robustness of the slides etc.

A circlip made from one coil of a spring is used to prevent the chuck assembly falling out if it is inadvertently motored right off the leadscrew. Limit switches are not fitted, as their complication outweighs their advantages in this application. Stepper motors are not damaged by being stalled for long periods and the torque of the motor is insufficient to damage the leadscrew etc. The screw may jam if inadvertently wound to the top, but when it has been run in and is nice and free it will "unjam" itself in a few moments on reversal.

The drawing shows a pin chuck mounted to take the electrode; this obviously can be altered to suit individual constructors' whims.

The second item is the motor drive unit and power supply. The stepping motor is driven by a four-phase electrical signal which is generated by an electronic logic system from a 12 V D.C. supply, the smaller motor taking .70 amp and larger one 1.1 amp from this supply; in addition the logic unit takes 25 amp at + 5 V which is stabilised from

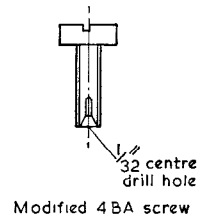
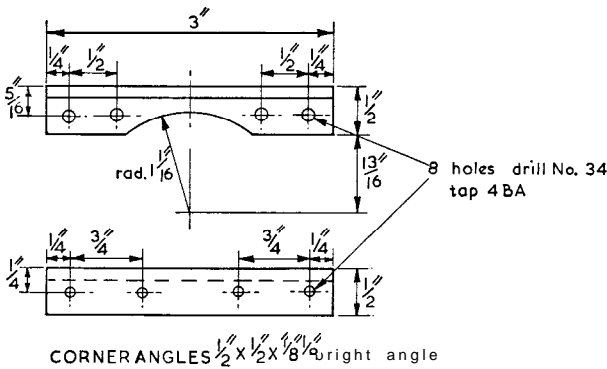
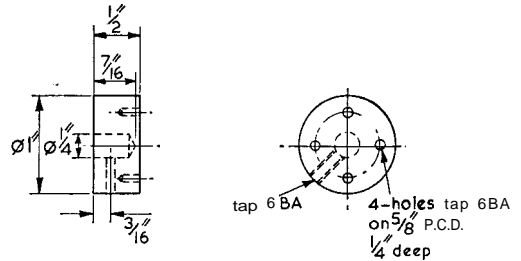
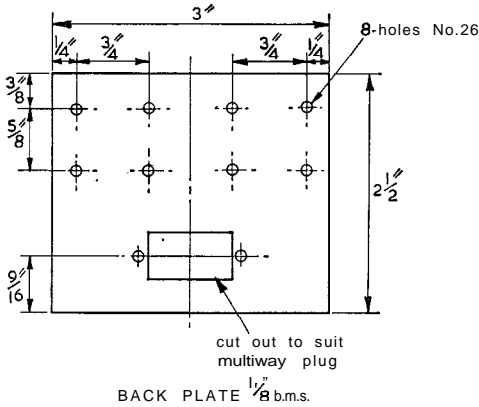
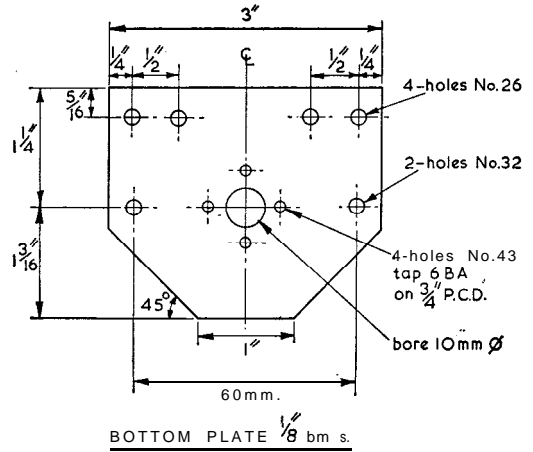
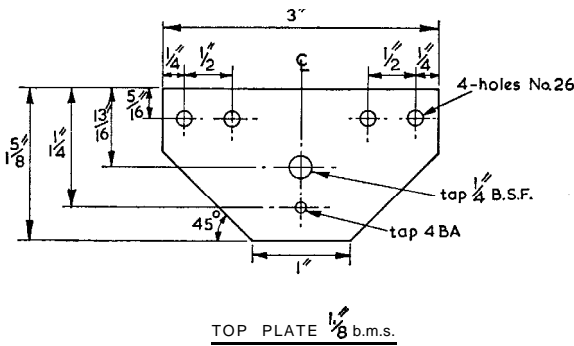

## EROSION HEAD FOR SMALL MOTOR

the + 12 V rail. The pulses which feed the logic unit are generated by a very simple unijunction oscillator "S" and resistor R3 controls their frequency and hence the motor speed.

The motor direction is determined by a voltage into the logic unit at D, zero volts is arranged to raise the head and +5 V to lower the head. Consequently when the electrode is clear of the job it is at a high voltage and causes the head to descend. When it makes contact, the electrode voltage drops

to zero and the head is instantly reversed. The stepping motor does not overrun. This process continues and each time the electrode leaves the job, capacitor C1 charges up to the supply voltage through resistor R2 and a spark occurs when the electrode next touches the job.

The rate of penetration depends on the energy stored in capacitor C, ; a larger one or higher voltage gives faster penetration, but a poorer surface finish. For safety reasons it is not usual to run the

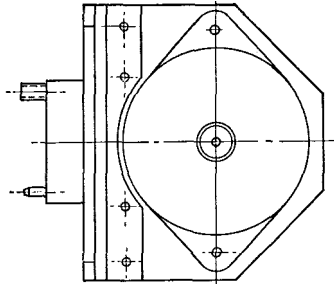
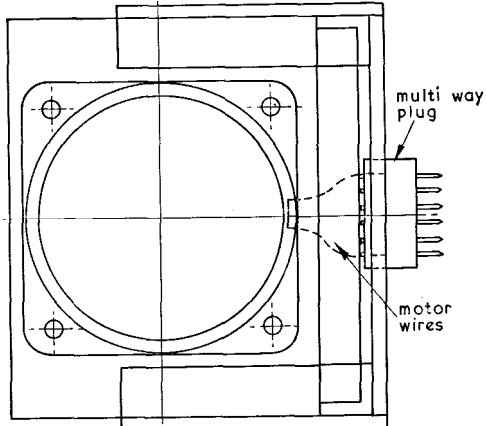
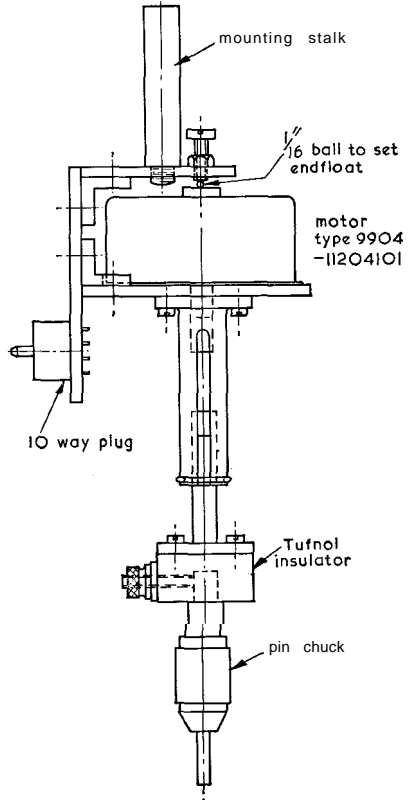
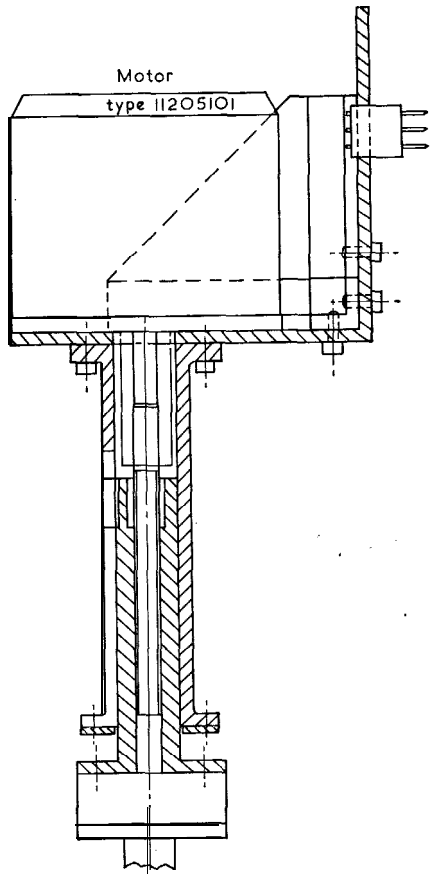

PLAN : top plate removed

**SPARK EROSION MACHINE HEAD USING  
TYPE 11205101 MOTOR**

All fixings 4 BA and 6BA cop screws

electrode above about 200 V; most commercial machines run around 100-150 V.

This system is, of course, the simplest and most basic one; large machines generate distinct pulses of energy controllable in frequency and duration, but this complication is not warranted for our application.

The circuit diagram will show all the parts required for this unit. Some constructors with an interest in electronics will no doubt have many of the items. The transformer used in the prototype was an old valve radio transformer, the two heater windings

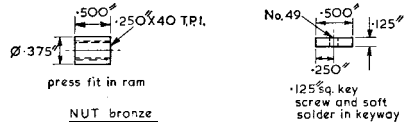
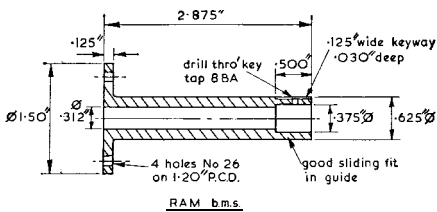
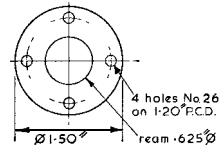
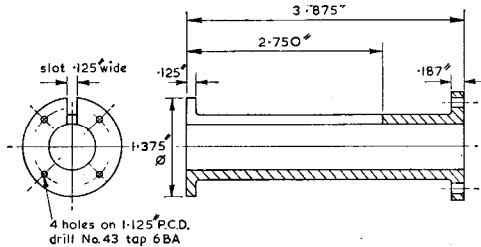
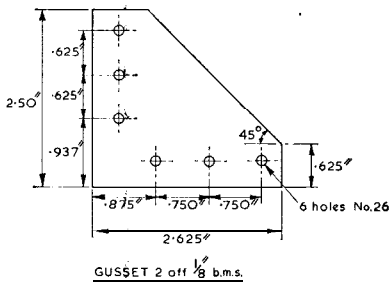
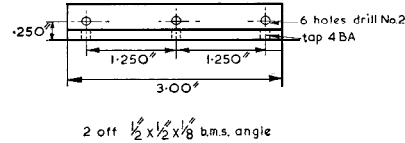
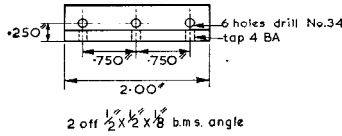
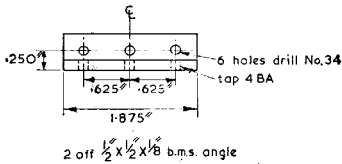
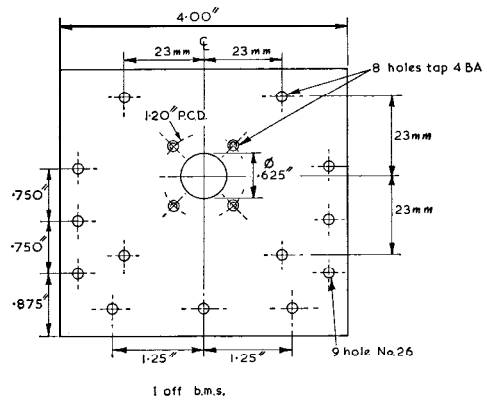
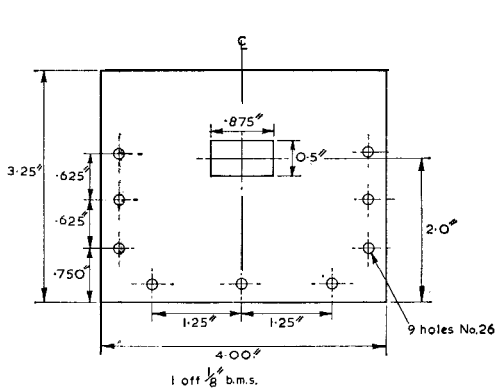

in series being convenient for the low voltage supplies and half the 250-0-250 V secondary rated at 100 mA for the electrode supply; however this gives an electrode voltage of some 300 volts and care is needed if nasty shocks are to be avoided—the lower voltage should be used for general safety.

The power unit circuit shows the discharge capacitor as  $2\mu\text{F}$ ; this is satisfactory, but it speeds things up if another one, up to 8 or  $12\mu\text{F}$ , is available and is connected when required straight across the electrode and work—it also works better with reasonably short leads, say 12 in. or so. Special capacitors are made for this sort of work, but standard paper insulation types work quite well and

they are fairly cheap at surplus stores. The voltage rating must be at least 300 for a 150 V transformer winding. Two controls are provided on the box—mains on-off and head raise and lower. This latter control also disconnects the electrode power in the raise position and reconnects it in the lower position.

The last item is the work holder and dielectric supply. To extinguish the spark rapidly and wash away debris from the working point, spark erosion machines always use a dielectric; this is usually ordinary paraffin, although more recently, to reduce fire risks, a light mineral oil is sometimes used. I've never had a fire with paraffin, but a handy

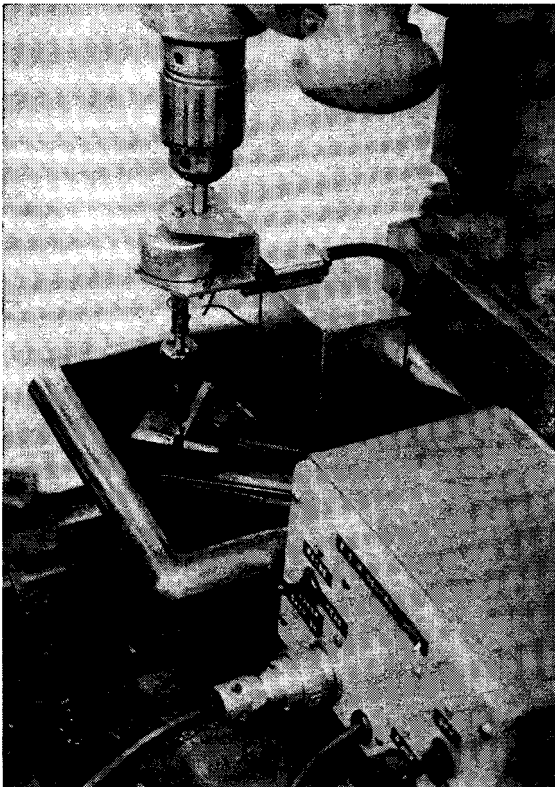
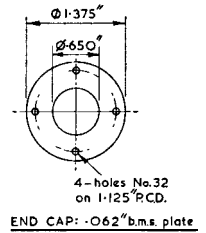
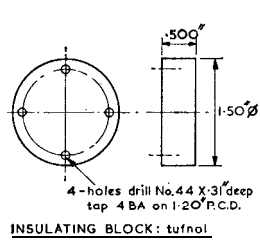
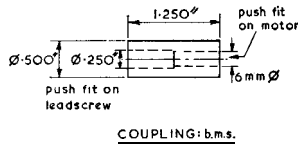
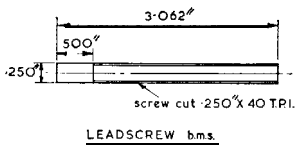

The spark erosion machine in use.

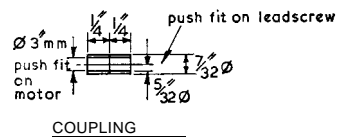
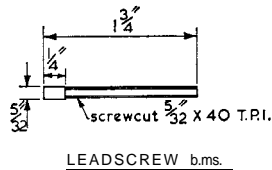
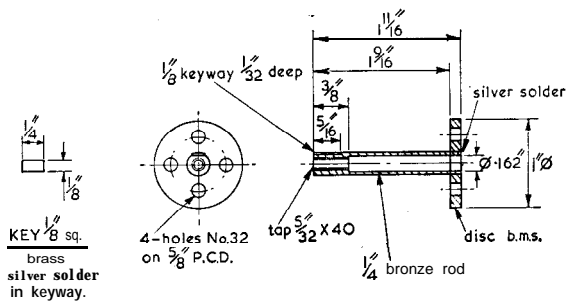
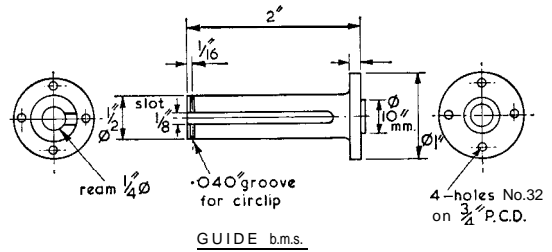

fire extinguisher is a wise precaution. The work may be fully submerged, or the paraffin may be poured over the work. If working submerged a means of agitating the dielectric is still required and one cannot see what is going on so easily, as the dielectric becomes black in no time, but it does stop it splashing around. I use a very small centrifugal pump to pour the dielectric over the work-one made the wrong direction of rotation for a small petrol engine many years ago-they come in useful if kept long enough! This one has a rotor about 5/8 in. dia., and it is driven with one of the small surplus induction motors now available, coupled by a bit of plastic tube between the shafts. The pump is bolted in the corner of the tray with its motor above. The type of electric pump used for car windscreen washers would probably be

satisfactory but I have not experimented with one of these. The work must be clamped down and earthed to the power unit-it is surprising how quickly a small vice and component will wander about under the light pecking action of the electrode.

To be continued



**The  
spark  
erosion  
machine  
in  
operation.**

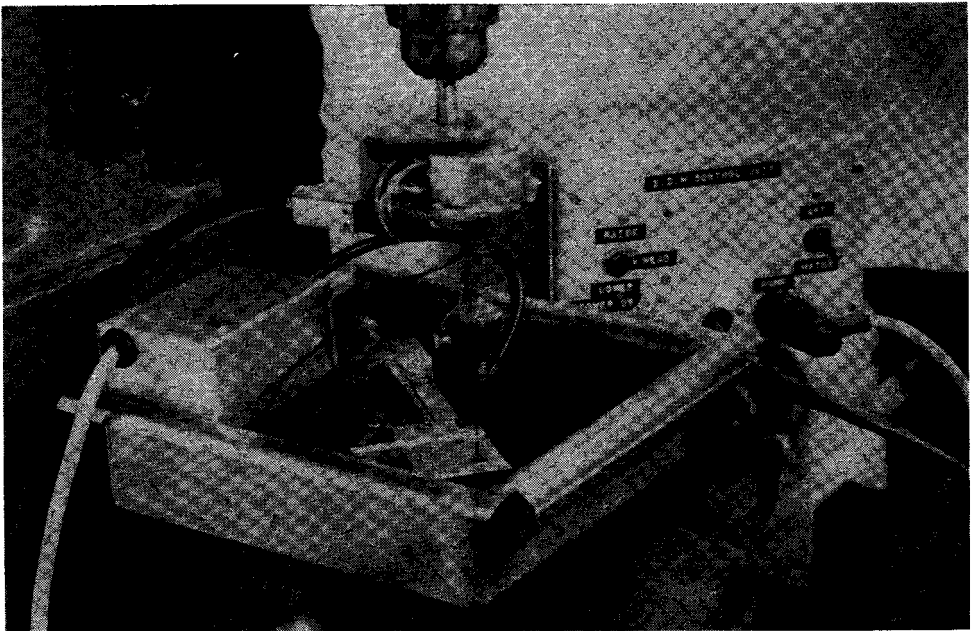

to put on the market a kit of parts for this item, which will include the stepping motor. These may be purchased as a basic kit or with the printed circuit card only wired and tested or as a complete wired and tested control box.

**Transformer:**

Primary: 200-240 V  
SEC (1) 11.3 v.  
SEC (2) 250 V.  
Ex-valve type radio :  
Use 6.3 V and 5 V windings and half of 250-o-250 winding.  
If motor runs in wrong direction interchange 4 and 6 with 8 and 10 in pairs.  
Head must descend with S2 A open.

**Motor type 11204101 R1-22 Ω 3 W**

**Motor type 11205101 R, — 15 Ω 3 W**  
**C<sub>1</sub> 2 μF to 16 F.**

R2 may be made up of several lower wattage wire-wound resistors

Note S<sub>1</sub>, A closed when S2 B open.

S<sub>1</sub> -mains switch.

S<sub>2</sub> — raise-lower switch.

Drive board requires socket type F050/037/01012.

**Mofor connections:**

|                   | <b>Pin No.</b>                |
|-------------------|-------------------------------|
| Yellow front coil | 4                             |
| Grey front coil   | 6                             |
| Yellow rear coil  | 8                             |
| Grey rear coil    | 10                            |
| Black front coil  | } Any order to R <sup>1</sup> |
| Red front coil    |                               |
| Black rear coil   |                               |
| Red rear coil     |                               |

## JEYNES' CORNER

E. H. Jeynes on "Steam on the Farm"

THE FIRST RECORDS of portable steam engines that I have been able to trace were those of Edward Cartwright, patent 1801, and Matthew Murray who patented his in 1802; there is, however, no direct evidence to show that either of these engines were used on a farm. Therefore the combined engine and boiler supplied by Trevithick to a Cornish squire in 1812 would appear to be the first authentic application of steam power to farm work; there is an engine in the Science Museum, London, which may be the identical one.

Threshing out grain was carried out by manual labour using flails up to the beginning of the nineteenth century, after which threshing machines came into more general use. Having been invented about 1760, these were driven by animal power, the threshing machine generally being built in to the barn, with the horsewheel in an adjoining building. The power was

transmitted by spur gearing; these gearwheels were run in pairs, one had moulded cast iron teeth, and the mating wheel had inserted wooden teeth. After being run in with a special compound which contained white lead they ran very well together. As the horizontal drive shaft from the horse gear was overhead, the threshing machines were usually placed on a floor raised up to this height in the barn, and it may be for this reason that most of the early steam engines adapted for driving these machines were of the 'crank' type, developed into "Wall" engines being either built into the wall, or having their framework bolted to the wall. These latter had only one main bearing on the frame, the other main bearing being carried on the threshing machine. The former had two main bearings and a double webbed crank throw running between them, while the latter had perforce an overhung crank. These early engines usually were supplied with steam from an egg-ended boiler, externally fired, and some were condensing.

The flywheels of these wall engines were usually about 6 to 7 ft. dia., and many had oval rims and square holes through the boss, being centred and

# IMPROVEMENTS TO THE SPARK EROSION MACHINE

by Roy Amsbury

BACK IN 1976 (*Model Engineer* Nos. 3541 and 3542) I described in these pages a simple spark erosion machine, usually called E.D.M. (Electro-Discharge Machining) in Technical Journals. There seems to be quite a bit of interest in this type of machine and I have had numerous enquiries about it over the intervening years. I have in this time found some deficiencies in my machine and made various improvements which may be of interest to other readers, so here goes.

## Mechanical Changes

The first part to give trouble was the electrode guide which, though simple to make, soon

developed rotational play in its keyway. In the new one this guide has been replaced by a square bar running in a corresponding square guide. Mine appeared one day as a very welcome present from a fellow model engineer who had seen my new sketches. The motor remains unchanged, the load it carries is only the weight of the electrode irrespective of workpiece current, so unless one is doing quite large work there is no need of the larger motor mentioned in my previous article.

The leadscrew and nut comes in for some wear if the machine is used a lot and maybe a case for an increase in its size which, in turn, due to the greater friction could possibly call for the bigger motor. Of

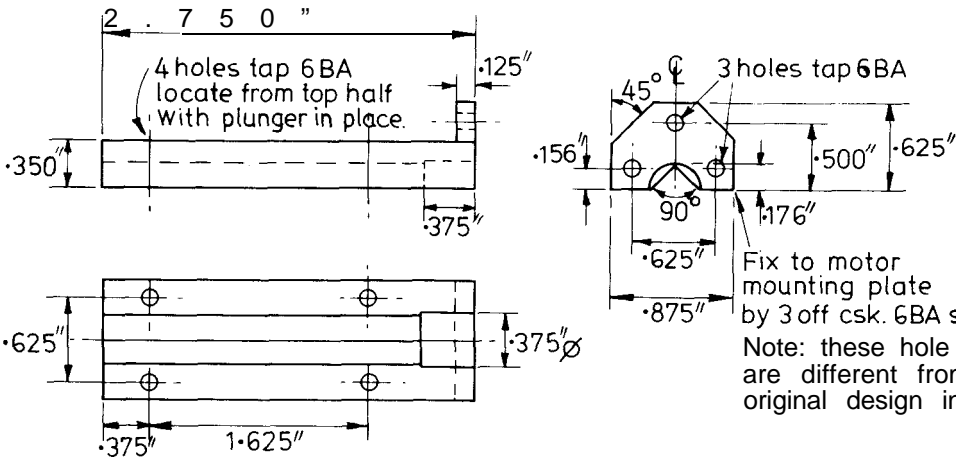

HALF GUIDE: b.m.s.

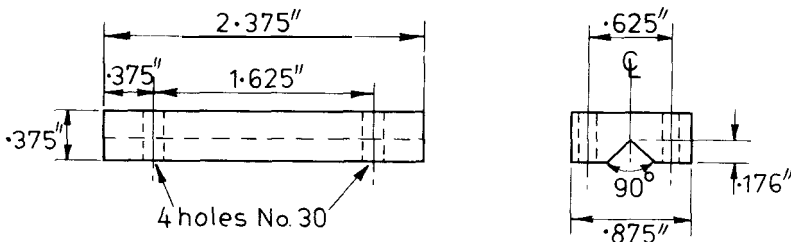

HALF GUIDE: bms.

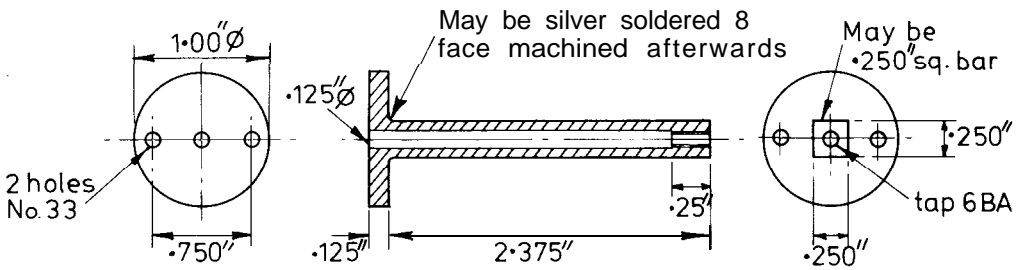

SECTION

PLUNGER : brass or bronze

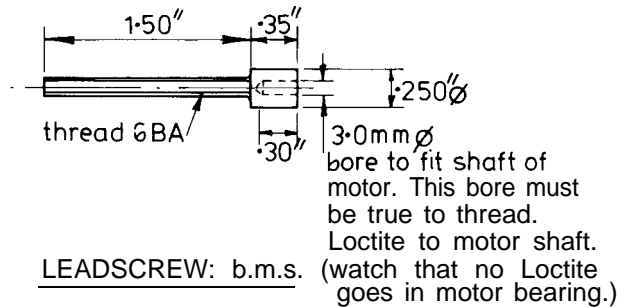

LEADSCREW: b.m.s. (watch that no Loctite goes in motor bearing.)

©

course if one comes by a small ball screw and nut these are ideal, but they are a bit expensive to buy unless one is contemplating a lot of work.

**Electrical Changes**

The next part to be improved was the power supply. The original one used a fairly readily available

old valve radio mains transformer. This gave an unnecessarily high voltage to the electrode which could give a nasty shock, and even with considerable care one occasionally got "bitten". That unit also only gave about 0.1 amp and made progress very slow when using electrodes of some 1/4 sq. in. area.

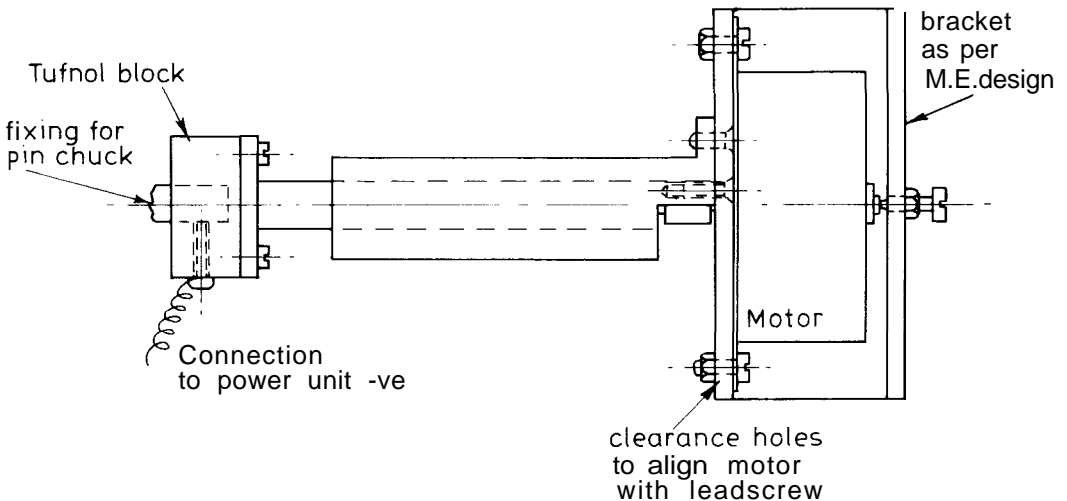

G.A. OF MODIFIED GUIDE FOR SPARK EROSION MACHINE

©

A further change had to be made in the motor driving circuit, as the manufacturers discontinued the original motor drive board and an integrated circuit became available, requiring somewhat different circuitry. The new unit gives a discharge current up to 4 amps at about 50 volts. these may be varied a bit if one comes by a transformer which is not quite the same as my design.

In the previous circuit the discharge current was limited by a high wattage resistor under electrode short conditions. This resistor becomes an "electrc fire" if one attempts to use the same technique at 4 amps, and hence an electronic switching arrangement has been incorporated to give the necessary short circuit protection. The motor drive circuit fig. 1 uses a four gate I.C. type MC 14011 (or equivalent) to generate the motor drive signal (clock generator) and its frequency may be altered by changing C1. This I.C. feeds the new four phase logic generator SAA 1027, and this I.C. will drive the small motor type 11204101 directly as shown. The total current required is then within the 12 volt 1 amp power supply shown in fig. 3.

If you wish to use a larger stepping motor, there are a number of manufacturers making these, then the output circuit of fig. 2 should be used, this will cater for quite powerful motors up to 4 amps per phase, they must be four phase motors. The motor

power supply will have to be uprated to suit the larger current and you may need to increase the voltage as well, about 30 volts being the limit. Resistors R determine the motor current, as in stepping motors the motor windings only drop a few volts. usually between 2 to 6 volts at rated current. The value R is readily calculated by Mr. Ohms' law, as only one phase of the pair is taking current at any one time. If one has a supply of 30 volts and require to limit the current to about 2 amps. R is  $15 \Omega$  (the motor and transistor "on" voltage can be ignored in most cases). The resistor has to dissipate a lot of power however. in this example 60 watts.

**Electrode Power**

The second power unit on fig. 3 is the one that does the work, comprising a 40 volt 4 amp transformer with rectifier and large smoothing capacitor C2. The three transistors shown form the switching circuit. This cuts off the current to the discharge capacitors C3 whilst they are discharging through the workpiece. Quite a bit of power is dissipated in these transistors and the two current sensing diodes D1. They should be mounted on a heat sink of at least 12 sq. in., or on the outside of the box with some cooling fins. The workpiece current is controlled by switching in one of three capacitors, these should ideally be special high discharge current capacitors, but I have had quite good results using

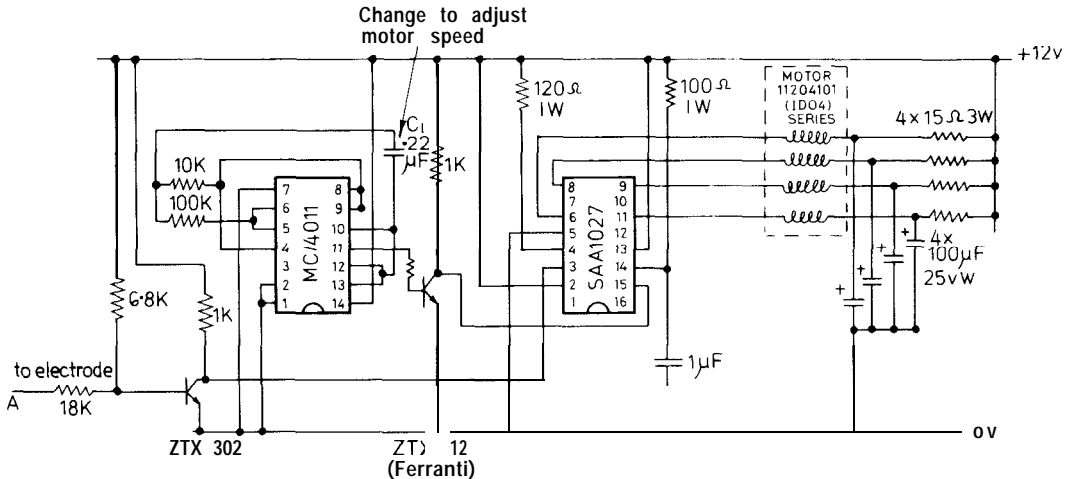

STEPPING MOTOR DRIVE UP TO 350mA/PHASE (ID04 series) Fig 1

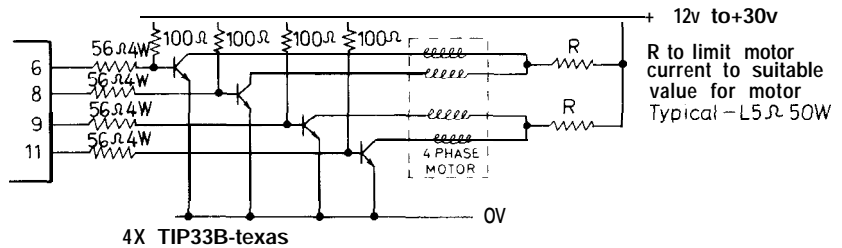

OUTPUT CIRCUIT FOR HIGHER POWER MOTORS UP TO 4A/PHASE

Fig 2

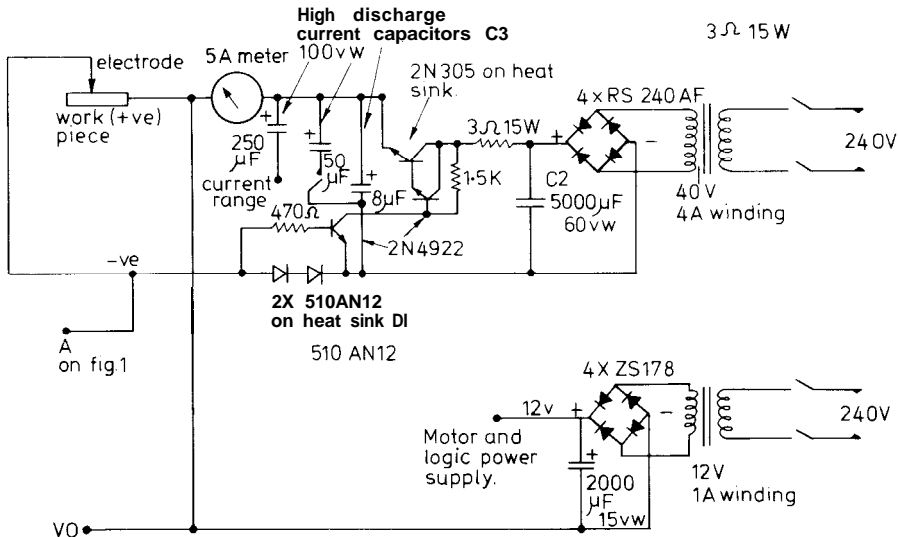

Fig. 3

normal electrolytic capacitors, provided the voltage rating is at least 100 volts.

The current meter shown is a "nice to have" instrument but not essential. For those readers who have a few electronic bits in the scrap box, the power transformer is only shown as 40 volt 4 amp because I happen to have one of this rating. The capacitors charge up to the peak voltage of course, of some 56 volts and this is at the lower end of the working range for E.D.M. machines but quite satisfactory work can be done with this power, most commercial machines work at around 100 volts.

#### Workpiece Tank

On my original machine I arranged to pour the electrolyte over the work with a small pump. The electrolyte being either paraffin or a very light oil. This works fine on small work, but the sparking causes the electrolyte to splash quite a way around the machine and it has been suggested that it could be a fire risk with paraffin, although I never had any trouble from this score. I now immerse the work completely in the electrolyte bath, but one needs a

reasonable sized bath, about twelve inches square, and a good pump to empty it quickly to see how the machining is progressing. Possibly an old washing machine pump would be suitable, although some of these have rubber impellers which might not stand paraffin or oil. The base of the tank should be fitted with a plate with either a few tee slots, or an array of tapped holes for fixing clamps to hold the work down.

#### Electrodes

Commercial users make the electrodes from a special copper tungsten alloy which does not burn away very fast under the action of the spark. However I don't expect many constructors will have this material available, and the next best substitute is plain copper. The electrodes get burnt away of course and to obtain an accurate shape it is necessary to first use a roughing electrode and then a finishing one to size up the workpiece. The motors may be obtained from McLennan Servo Supplies Ltd., Yorktown Industrial Estate, Doman Road, Camberley, Surrey.

# MODEL ENGINEER HOT AIR ENGINE COMPETITION

To be held at the 1982 Model Engineer Exhibition

Closing Date for Entries for this popular Competition  
is 16th October, 1981

Applications should be made to the Exhibition Manager