



Standard AC Motors

| | |
|--|------|
| Features and Product Line of AC Motors | A-2 |
| List of Standard AC Motor Types | A-6 |
| Guide for Motor Selection and Use | A-7 |
| General Information..... | A-10 |
| Q & A..... | A-25 |
| Glossary | A-28 |

ORIENTAL MOTOR GENERAL CATALOG

Induction Motors

A-34

Reversible Motors

A-74

Synchronous Motors

A-102

Torque Motors

A-106

Speed Control Motors

FBLII Series

A-120

HBL Series

A-132

SC Series

A-142

US Series

A-156

Component Package Type

A-170

Brake Motors

Electromagnetic Brake Motors

A-180

Clutch and Brake Motors

A-194

Washdown Motors

FPW Series

A-203

Gearheads

A-213

Linear Heads

A-227

Accessories

A-259

Features of Standard AC Motors

■ Features

Standard AC motors that rotate when connected to a commercial power source are widely used in everything from household appliances to automated factory production equipment. These motors can be used anywhere. In 1966, we introduced the K series of standard compact AC motors, and we have continued to improve this best seller ever since. Today's motors boast improvements in temperature characteristics, are quieter, and perform better in demanding modern applications. Many changes have improved performance in specialized applications. The basic design, including the mounting dimensions, and the usability have endured. These motors give worry-free performance over a long service life. Standard AC motors offer many benefits. The following are some of the more important:

1. High Reliability

All that is required to rotate a standard compact AC motor is a commercial power supply and a capacitor. Motors for three-phase power supplies do not even require capacitors. They are the simplest way to get rotational operation from a motor. Their simplicity only improves the reliability and service life they provide.

2. Multiple Functions

The two basic motor types, the continuous-operation induction motor and the forward/reverse-operation reversible motor, are supplemented by speed control functions and an electromagnetic brake to hold loads. These are available in a wide variety of combinations that allow users to select the one best suited to their needs.

3. Quiet

Over the years, new applications have demanded lower levels of noise, so we have made these motors ever quieter. We have also pushed development of low-noise gearheads. Virtually all of the gearheads listed in this catalog are low-noise gearhead types.

● Pinion Shaft and Round Shaft

There are two types of shafts: the pinion shaft is used to connect a gearhead (specialized speed-reducing devices) to the standard compact AC motor output shaft, and the round shaft is used when the motor is operated without a gearhead.

● Motors and Gearheads

Gearheads reduce the speed (r/min) of motors and simultaneously increase the torque. Except for some geared motors, motors and gearheads are sold separately. By matching size and pinion specifications, the full lineup of gear ratios can be combined. There are between 8 and 23 gear ratios for each size motor.

● Geared Motors

The designs of some motors and gearheads have been optimized for special applications where the motors are combined in one assembly with dedicated gearheads. These geared motors are pre-assembled in the factory and can not be removed or changed. The dust-and water-resistant **FPW** series motors are gear motors.

● Speed Control Packages

Speed control package are comprised of a motor and a control pack. The motors cannot be combined with other control packs.

Package Products

• Speed control motors

FBL II series

HBL series

SC series

US series

Product Line of Standard AC Motors

Standard AC motors can be divided into three categories according to the motor's function:

1. Constant speed motors
2. Speed control motors
3. Motors equipped with a brake function

Constant Speed

Induction Motors for uni-directional operation A-34

Induction motors are the most commonly used AC motor. Capacitor-run, single-phase and three-phase motors are available. Lead type, terminal box type, and conduit box type motors are available. The **BH** Series is also available with BH6G2-□ gearheads to provide 347lb-in (40N·m) of maximum permissible torque.



Reversible Motors for bi-directional operation A-74

These are capacitor-run, single-phase motors. While they are induction motors in basic operating principle, they have a built-in friction brake to improve instantaneous reversing characteristics. These motors are suited for applications where the motor must switch frequently from one direction to the next.



Synchronous Motors A-102

These motors provide rotation at a fixed speed in synchronization with the frequency of the power source.

Torque Motors A-106

The speed and torque can be set to any desired level by changing input voltage.



Speed Control

Speed Control Motors

FBL II, HBL Series

A-120

These are packaged sets combining a brushless DC motor and a driver that operates from a 100-115V AC power source (DC24V, DC48V for the **HBL** series).

High speeds (**FBL II**: 3000r/min ; **HBL**: 2000r/min), can be obtained while maintaining a constant torque over the entire speed range.

SC Series

A-142

This package set combines a motor and speed control pack.

US Series

A-156

Control units combine a control circuit, a speed potentiometer and a capacitor in one device.

Connection between the motor and control unit is made easy by a snap-on connector.

Component Package Type

A-170

Select a custom combination of motor and control pack to suit the particular need or application.

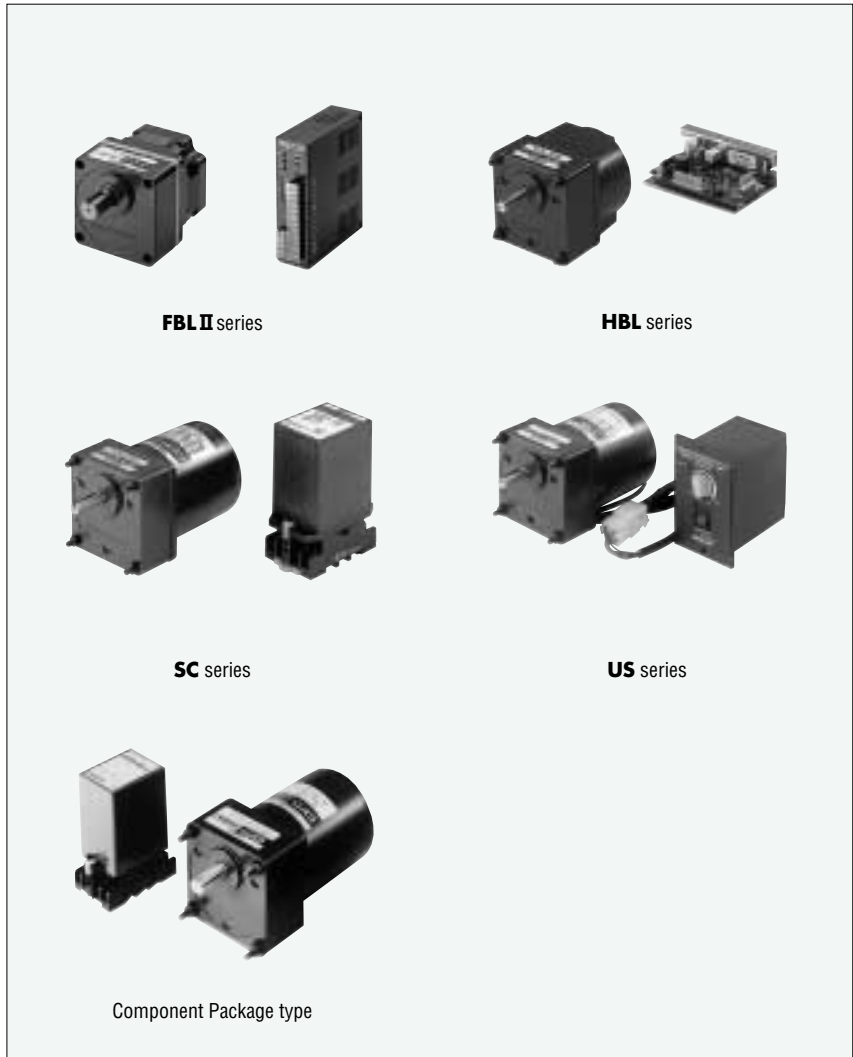

Brake

Electromagnetic Brake Motors

A-180

These motors are built with electromagnetic brakes. The brake, which activates when the power is shut off, offers reliable performance and excellent holding power. This brake can be used in case of power failure or other emergencies.

Clutch and Brake Motors

A-194

This motor combines clutch and brake mechanism with an induction motor. It is ideal for high-frequency starting and stopping, as well as position holding and positioning control.

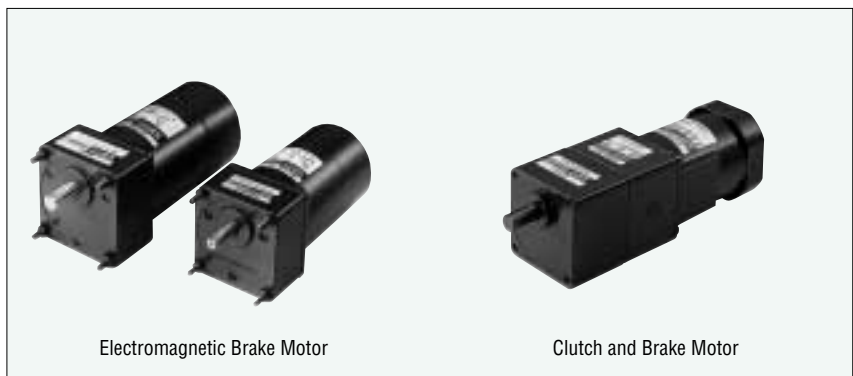

Washdown Motors

A-203

These geared motors provide splashproof and dust-resistant performance that meets the IP65 standard.



Gearheads

A-213

These dedicated gearheads can be connected directly to pinion shaft motors. The units shown at the right serve a variety of motor types and powers. A right-angle gearhead is also available for outputs between 25W and 90W.

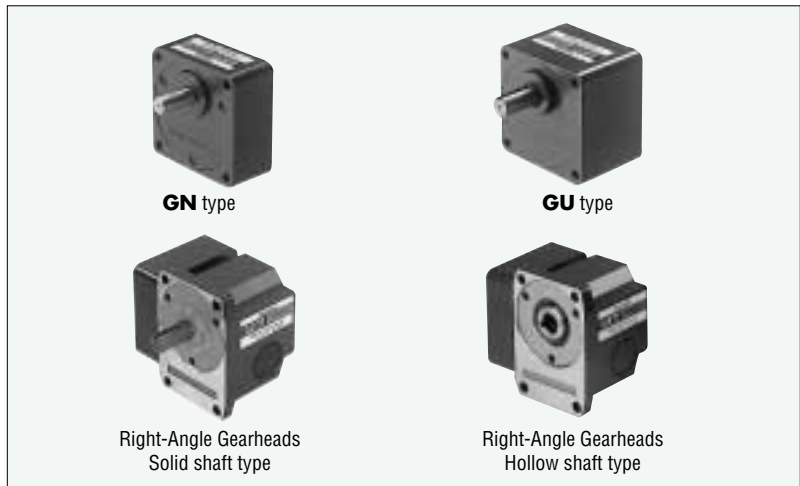

Linear Heads

A-227

The rack-and-pinion linear head is directly coupled to a standard AC motor, which makes linear action like pushing, pulling, lifting and lowering easy to engineer.

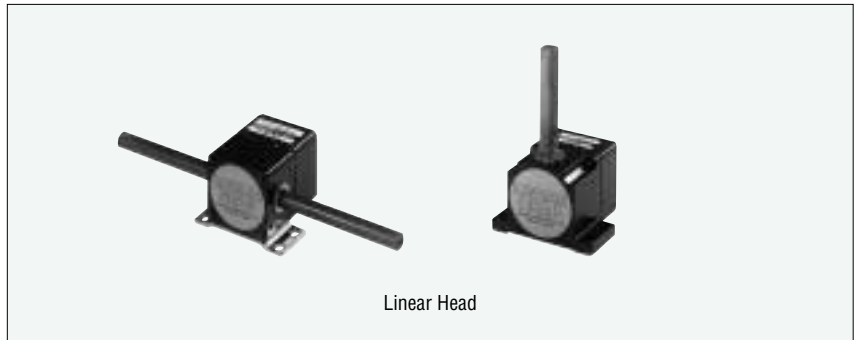

List of Standard AC Motor Types

| Motor Type | | Mounting Size | 1.64in.sq. (42mm sq.) | | | 2.36in.sq. (60mm sq.) | | | 2.76in.sq. (70mm sq.) | | 3.15in.sq. (80mm sq.) | | 3.54in.sq. (90mm sq.) | | | 4.09in.sq. (104mm sq.) | |
|--|--|--|--------------------------|------------------|------------------|--------------------------|------------------|------------------|--------------------------|--------------------|--------------------------|-----------------|--------------------------|--------------------|--|---------------------------|---|
| | | Output Size | 1W (1/750 HP) | 3W (1/250 HP) | 6W (1/125 HP) | 10W (1/75 HP) | 15W (1/50 HP) | 15W (1/50 HP) | 25W (1/28 HP) | 40W (1/18.5 HP) | 60W (1/12.5 HP) | 90W (1/8 HP) | 90W (1/8 HP) | 200W (1/3.73HP) | | | |
| Power Motors | Induction Motors | Lead Wire Type | ● | ● | ● | | ● | ● | ● | ● | ● | ● | | | | | |
| | | Cable Type | | | | | | | | | | | | | | | ● |
| | | 2-Pole High Speed Type | | | | | | | | ● | ● | ● | | | | | |
| | | Terminal Box Type | | | ● | | | | ● | ● | ● | ● | | | | | ● |
| | | Conduit Box Type | | | | | | | ● | ● | ● | ● | | | | | |
| | Reversible Motors | Lead Wire Type | ● | ● (4W) | ● | | ● | ● (20W) | ● | ● | ● | ● | | | | | |
| | | Terminal Box Type | | | ● | | | | ● | ● | ● | ● | | | | | |
| | Synchronous Motors | | | | ● (4W) | ● | | | ● (15W) | ● (25W) | | | | | | | |
| | Torque Motors | | | | | | ● (8W) | | ● (12W) | ● (23W) | | | | | | | |
| | Speed Control Motors | FBLII Series (Brushless DC Motor, 100-115V/200-230V AC Input) | | | | | | | | | | ● (75W) | ● (120W) | | | | |
| HBL Series (Brushless DC Motor, 24V/48V DC Input) | | | | ● (10W) | | | | ● | ● | ● | ● (100W) | | | | | | |
| US Series | | | | ● | | ● | | ● | ● | ● | ● | | | | | | |
| SC Series | | | | ● | | ● | | ● | ● | ● | | | | | | | |
| Component Type | | | | ● | | ● | | ● (22W) | ● | | | | | | | | |
| Brake Motors | Electromagnetic Brake Motors | | | | ● | | ● | | ● | ● | ● | ● | | | | | |
| | Clutch and Brake Motors | | | | | | | | | ● | ● | ● | | | | | |
| Gearheads | Gearheads | | ● | ● | ● | ● | ● | ● | ● | ● | ● | ● | | | | ● | |
| | Right Angle Gearheads | | | | | | | | ● | ● | ● | ● | | | | | |
| Linear Heads | Linear Heads | | ● | | ● | | | | ● | ● | ● | ● | | | | | |
| Washdown Motors | FPW Series | | | | | | | | ● | ● | ● | | | ● | | | |
| Accessories | Motor Mounting Brackets (Metric Size) | | | | | | | | | | | | | | | ● | |
| | Motor Mounting Brackets (Inch Size) | | ● | ● | | ● | | ● | | | ● | | | | | | |
| | Flexible Coupling | | ● | ● | ● | ● | ● | ● | ● | ● | ● | ● | | | | ● | |

Guide for Motor Selection

This chart can help you determine which motor best meets your application needs.

| Constant Speed | Desired performance and functions | Output Power (W) | Run state | | Additional functions | | | Voltage | | | |
|-----------------------------|-----------------------------------|------------------|-----------------|-------------------------|----------------------|-------------------------------|-----------------------------------|--------------|--------|-------------|---|
| | | | Uni-directional | bi-directional | Terminal Box Type | Conduit Box Type ^① | Right-Angle Gearhead ^② | Single-Phase | | Three-Phase | |
| | | | | | | | | 115VAC | 230VAC | | |
| Big power | A-68 BH Series | 200 | ○ | | ○ | | | ○ | ○ | ○ | |
| | | | Standard type | A-34 Induction Motor | 1~90 | ○ | | ○ | ○ | ○ | ○ |
| | | | | Reversible Motor | 1~90 | | ○ | | ○ | ○ | |
| Synchronous speed operation | A-102 Synchronous Motor | 4~25 | ○ | | | | ○ | | | | |

① Sometimes the desired performance is not provided by single products. For details, refer to the specifications values for each product.

② Right-Angle gear heads are combined with 25W, 40W, 60W and 90W output type motors.

| Brake | Desired performance and functions | overrun | Operation cycle | Output power (W) | Voltage | | |
|--------------------------|--------------------------------------|----------------|-----------------------|------------------|--------------|-------------|--------|
| | | | | | Single-Phase | Three-Phase | DC |
| High-frequency | A-194 C•B Motor | 1 revolution | 100 times/minute max. | 40-90 | ○ | | |
| | | | | | 115VAC | 230VAC | 230VAC |
| Power off activated type | A-180 Electromagnetic Brake Motor | 2~3 revolution | 50 times/minute max. | 6-90 | ○ | ○ | ○ |

| Speed Control | Desired performance and functions | Speed Range (r/min) | Output Power (W) | Additional functions | | | Voltage | | | |
|-------------------------------------|------------------------------------|---------------------------|----------------------|----------------------|--------|-----------------------------------|-----------------|-------------|----|---|
| | | | | Brake | SSSD | Right-Angle Gearhead ^② | AC Single-Phase | Three-Phase | DC | |
| Constant Torque Speed Regulation-1% | A-120 FBLII Series | 300~3000 | 75,120 | ○ | ○ | | ○ | ○ | ○ | |
| | | | | 115VAC | 230VAC | 230VAC | | | | |
| Three-Phase 200-230V | A-132 HBL Series | 300~2000 | 10~100 | ○ | | | | | | ○ |
| DC24(48)V Stand-alone operation | Simple wiring and simple operation | A-156 US Series | 90~1600 ^① | 6~90 | | | ○ | ○ | | |
| | | A-142 SC Series | 90~1600 ^① | 6~60 | | ○ | ○ | ○ | | |
| | | A-170 Component type | 90~1700 ^① | 6~40 | | | ○ | | | |
| | | | | | | | | | | |

① The variable speed range displayed is for a power frequency of 60 Hz.

② Right-Angle gear heads are combined with 25W, 40W, 60W and 90W output type motors.

| Special purpose | Desired performance and functions | Performance and functions | Output power (W) | Voltage ^① | | |
|----------------------------|-----------------------------------|---|------------------|----------------------|-------------|--------|
| | | | | Signal-Phase | Three-Phase | DC |
| Dust-resistant Splashproof | A-203 FPW Series | IP65 (Geared motor) | 25-90 | ○ | ○ | ○ |
| | | | | 115VAC | 230VAC | 230VAC |
| Torque Control | A-106 Torque Motor | Locked rotor operation Suitable for winding applications | 8-23 | ○ ^① | | |

① The torque motor input voltage can be varied between 60 VAC and 115 VAC.

Selection Procedure

1. Required Specifications

First, determine the basic required specifications such as operating speed, load torque, power supply voltage and frequency.

2. Calculate the Operating Speed

Induction and reversible motor speeds cannot be adjusted. Motor speed must be reduced with gearheads to match the required machine speed. It is therefore necessary to determine the correct gear ratio.

3. Calculate the Required Torque

Calculate the required torque and speed to select a motor and gearhead.

4. Select a Motor and Gearhead

Use the required torque and speed to select a motor and gearhead.

5. Confirm the speed

In a single-phase induction motor, starting torque is always lower than the rated torque. Therefore, to drive a frictional load, select the speed on the basis of starting torque. This will cause the actual speed to exceed the rated speed. Also, the motors are designed so that increases in motor temperature are at their lowest when operating close to the rated speed of rotation.

■ EXAMPLE 1

Here is an example of how to select an induction motor to drive a belt conveyor.

In this case, a motor must be selected that meets the following basic specifications.

Required specifications and structural specifications

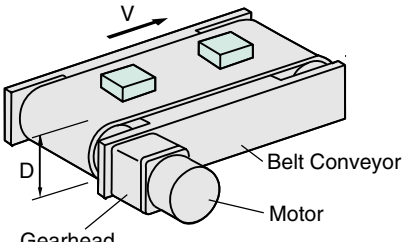

Total weight of belt and work $W = 30$ lb.
 Friction coefficient of sliding surface $\mu = 0.3$
 Drum radius $D = 4$ inch
 Weight of drum $W_2 = 35.27$ oz
 Belt roller efficiency $\eta = 0.9$
 Belt speed $V = 7$ inch/s $\pm 10\%$
 Motor power supply Single phase 115VAC 60Hz

1. Determining the Gearhead Reduction Ratio

Speed at the gearhead output shaft:

$$N_G = \frac{V \cdot 60}{\pi \cdot D} = \frac{(7 \pm 0.7) \times 60}{\pi \times 4} = 33.4 \pm 3.3 \text{ r/min}$$

Because the rated speed for a 4-pole motor at 60Hz is 1450~1550 r/min, the gear ratio (i) is calculated as follows:

$$i = \frac{1450 \sim 1550}{N_G} = \frac{1450 \sim 1550}{33.4 \pm 3.3} = 39.5 \sim 51.5$$

From within this range a gear ratio of $i=50$ is selected.

2. Calculating the Required Torque

On a belt conveyor, the greatest torque is needed when starting the belt. To calculate the torque needed for start-up, the friction coefficient (F) of the sliding surface is first determined:

$$F = \mu W = 0.3 \times 30 = 9 \text{ lb.} = 144 \text{ oz.}$$

Load torque (T_L) is then calculated by:

$$T_L = \frac{F \cdot D}{2 \cdot \eta} = \frac{144 \times 4}{2 \times 0.9} = 320 \text{ oz-in}$$

The load torque obtained is actually the load torque at the gearhead drive shaft, so this value must be converted into load torque at the motor output shaft. If the required torque at the motor output shaft is T_M , then:

$$T_M = \frac{T_L}{i \cdot \eta_G} = \frac{320}{50 \times 0.66} = 9.7 \text{ oz-in}$$

(Gearhead transmission efficiency $\eta_G = 0.66$)

Look for a margin of safety of 2x, taking into consideration commercial power voltage fluctuation.

$$9.7 \times 2 = 19.4 \text{ oz-in}$$

The suitable motor is one with a starting torque of 19.4 oz-in or more. Therefore, motor **5IK40GN-AWU** is the best choice. Since a gear ratio of 50 is required, select the gearhead **5GN50KA** which may be connected to the **5IK40GN-AWU** motor.

3. Inertial load check

Roller moment of inertia

$$J_1 = \frac{1}{8} \times W_2 \times D^2 \times 2 = \frac{1}{8} \times 35.27 \times 4^2 \times 2 = 141 \text{ oz-in}^2$$

Belt and work moment of inertia

$$J_2 = \frac{W_1 \times (\pi \times D)^2}{(4 \times \pi^2)} = \frac{480 \times (\pi \times 4)^2}{(4 \times \pi^2)} = 1920 \text{ oz-in}^2$$

Gear head shaft load inertia

$$J = J_1 + J_2 = 141 + 1920 = 2061 \text{ oz-in}^2$$

Here, the **5GN50KA** permitted load inertia is: $J_G = 4 \times 50^2 = 10000 \text{ oz-in}^2$

See page A-22 to confirm this calculated value.

Therefore, $J < J_G$, the load inertia is less than the permitted inertia, so there is no problem.

Since the motor selected has a rated torque of 36.1 oz-in, which is somewhat larger than the actual load torque, the motor will run at a higher speed than the rated speed. Therefore the speed is used under no-load conditions (approximately 1740r/min) to calculate belt speed, and thus determine whether the product selected meets the required specifications.

$$V = \frac{N_M \cdot \pi \cdot D}{60 \cdot i} = \frac{1740 \times \pi \times 4}{60 \times 50} = 7.3 \text{ in/s}$$

(Where N_M is the motor speed)

The motor meets the specifications.

EXAMPLE 2

This example demonstrates how to select a motor with an electromagnetic brake for use on a tabletop moving vertically on a ball screw.

In this case, a motor must be selected that meets the following basic specifications.

Required and structural specifications

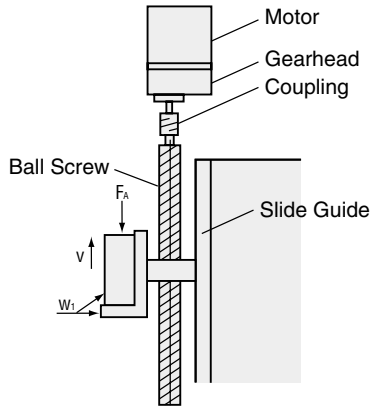

Total weight of table and work $W_t = 100\text{lb}$
 Table speed $V = 0.6 \text{ in/s} \pm 10\%$
 Ball screw pitch $P_B = 0.197\text{in}$
 Ball screw efficiency $\eta = 0.9$
 Ball screw friction coefficient $\mu_0 = 0.3$
 Friction coefficient of sliding surface
 (Slide guide) $\mu = 0.05$
 Motor power supply Single phase 115VAC 60Hz
 Ball screw total length $L_B = 31.5\text{in}$
 Ball screw shaft diameter $D_B = 0.787\text{in}$
 Ball screw material Iron (density $\rho = 4.64\text{oz/in}^3$)
 Distance moved for one rotation of ball screw
 External force $F_A = 0\text{lb}$
 Ball screw tilt angle $\alpha = 90^\circ$
 Movement time
 Brake must provide holding torque Intermittent
 operation, five hours per day

1. Determining the Gear Ratio

Speed at the gearhead output shaft:

$$N_G = \frac{V \cdot 60}{P} = \frac{(0.6 \pm 0.06) \times 60}{0.197} = 182 \pm 18 \text{ r/min}$$

Because the rated speed for a 4-pole motor at 60Hz is 1450~1550r/min, the gear ratio (i) is calculated as follows:

$$i = \frac{1450 \sim 1550}{N_G} = \frac{1450 \sim 1550}{182 \pm 18} = 7.2 \sim 9.5$$

From within this range a gear ratio of $i = 9$ is selected.

2. Calculating the Required Torque

F , the load weight in the direction of the ball screw shaft, is obtained as follows:

$$\begin{aligned} F &= F_A + W_t (\sin \alpha + \mu \times \cos \alpha) \\ &= 0 + 100 (\sin 90 + 0.05 \times \cos 90) \\ &= 100 \text{ lb.} \end{aligned}$$

Preload weight F_0 :

$$F_0 = \frac{F}{3} = 33.3 \text{ lb.}$$

Load torque T_L :

$$\begin{aligned} T_L &= \frac{F \times P_B}{2\pi\eta} + \frac{\mu_0 \times F_0 \times P_B}{2\pi} = \frac{100 \times 0.197}{2\pi \times 0.9} + \frac{0.3 \times 33.3 \times 0.197}{2\pi} \\ &= 3.8 \text{ lb-in} \end{aligned}$$

This value is the load torque at the gearhead drive shaft, and must be converted into load torque at the motor output shaft. The required torque at the motor output shaft (T_M) is given by:

$$T_M = \frac{T_L}{i \cdot \eta_G} = \frac{3.8}{9 \times 0.81} = 0.52 \text{ [lb-in]} = 8.32 \text{ oz-in}$$

(Gearhead transmission efficiency $\eta_G = 0.81$)

Look for a margin of safety of $2\times$, taking into consideration commercial power voltage fluctuation.

$$8.32 \times 2 = 16.64 \text{ oz-in}$$

To find a motor with a start-up torque of 16.64 oz-in or more, select motor **5RK40GN-AWMU**. This motor is equipped with an electromagnetic brake to hold a load. The gearhead with a gear ratio of 9 that can be connected to motor model **5RK40GN-AWMU** is **5GN9KA**.

Just as in Example 1, the rated motor torque is greater than the required torque, so the speed under no-load conditions (1740 r/min) is used to confirm that the motor produces the required speed.

3. Load inertia check

$$\begin{aligned} \text{Ball screw moment of inertia } J_1 &= \frac{\pi \times \rho \times L_B \times D_B^4}{32} \\ &= \frac{\pi \times 4.64 \times 31.5 \times (0.787)^4}{32} \\ &= 5.5 \text{ oz-in}^2 \end{aligned}$$

$$\begin{aligned} \text{Table and work moment of inertia } J_2 &= \frac{W_t \times A^2}{(4 \times \pi^2)} \\ &= \frac{1600 \times (0.197)^2}{(4 \times \pi^2)} \\ &= 1.57 \text{ oz-in}^2 \end{aligned}$$

$$\text{Gear head shaft total load inertia } J = 5.5 + 1.57 = 7.07 \text{ [oz-in}^2\text{]}$$

Here, the **5GN9KA** permitted load inertia is:

$$\begin{aligned} J_G &= 4 \times 9^2 \\ &= 324 \text{ oz-in}^2 \end{aligned}$$

See page A-22 to confirm this calculated value. Therefore, $J < J_G$, the load inertia is less than the permitted inertia, so there is no problem. As in Example 1, there is margin for the torque, so the rotation rate is checked with the no-load rotation rate (about 1750 r/min).

$$V = \frac{N_M \cdot P}{60 \cdot i} = 0.64 \text{ in./s}$$

(where N_M is the motor speed).

This confirms that the motor meets the specifications.

Precautions

1. Precautions for Installation

- Do not use in a place where there is flammable gas and/or corrosive gas.
- When installing the motor into your equipment, ensure that the motor lead wires (cable) are fixed and do not move. In addition, do not apply any pressure to these lead wires.
- Motors and Drivers for use only in equipment of protection class I .
- The motor housing must be mounted with a screw and spring washer to the ground point of the equipment.
- Installation must be performed by a qualified installer.

2. Precautions for Operation

- The Motor case and the Driver enclosure temperature can exceed 158°F (70°C) depending on operation conditions. In case motor is accessible during operation, please attach the following warning label so that it is clearly visible.
- Always turn off the power to the motor before conducting checks or performing work on the motor. Thermally protected motors will restart automatically when motor temperature falls below a certain level.
- The electromagnetic brake is designed to activate when power is removed. However, it may not arrest all loads completely. If this motor is designed to hold in emergency situations then a second method of stopping the load must be used to ensure to load stops. If this is not used injury or machine damage may result.



Connecting Gearheads to Motors

1. Connecting Gearheads

As the figure below shows, a gearhead is combined with a motor using the recessed areas on each unit as guides. The gearhead should be moved gently from side to side without forcing the pinion shaft against the plate on the gearhead or against the gear itself.

A tempting to put motor and gearhead together by force can result in damage to the gearhead.

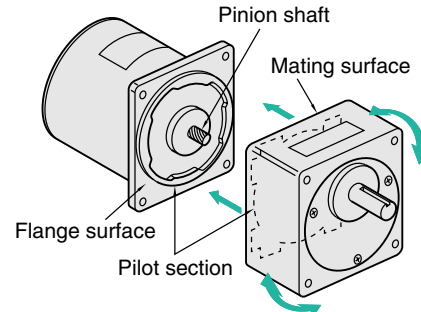

2. Mounting Motor/Gearhead to Machinery

The motor flange is provided with a recessed area that serves as a guide not only when assembling the motor and gearhead as shown in the above figure, but also when installing the motor/gearhead unit directly to the machinery. The figures demonstrate how to install a motor and gearhead in machinery. In this example, the motor/gearhead unit is mounted directly to the machinery, but dedicated mounting brackets such as those shown can also be used.



When mounting motors that have a built-in cooling fan, leave a space of approximately 0.5 inch behind the fan cover or make ventilation holes so as not to block the cooling intake.

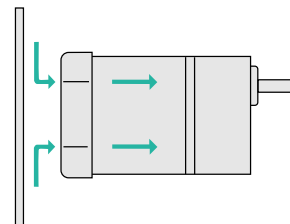

Installation conditions

Install the motor and capacitor in a location that meets the following conditions. Using the motor and capacitor in a location that does not satisfy these conditions could damage it.

- Indoors (this product is designed and manufactured to be installed within another device)
- Ambient temperature: 14°F~104°F (avoid freezing)
- Ambient humidity: 85% max. (avoid condensation)
- Not exposed to explosive, flammable or corrosive gas
- Not exposed to direct sunlight
- Not exposed to dust
- Not exposed to water or oil
- Place where heat can escape easily
- Not exposed to continuous vibration or excessive impact
- 328 feet (1000 meters) or less above sea level.
- Installation Category II , Pollution Degree2, Class I (for EN60950)

GN, GB and GU type Gearheads

Use the screws provided with the gearhead and secure all the parts so that there are no gaps between the motor flange face and the recessed area of the gearhead.

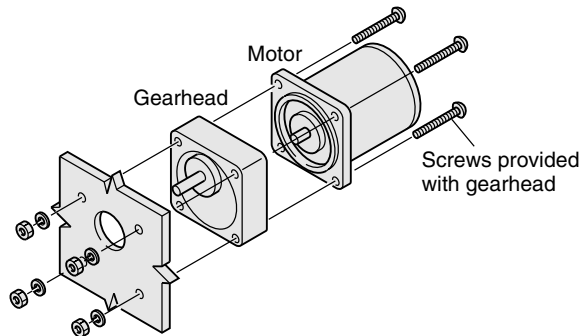

BH series

BH series motors are provided as a gearmotor for easy installation. Use the screws provided with the product to attach the unit from the motor side.

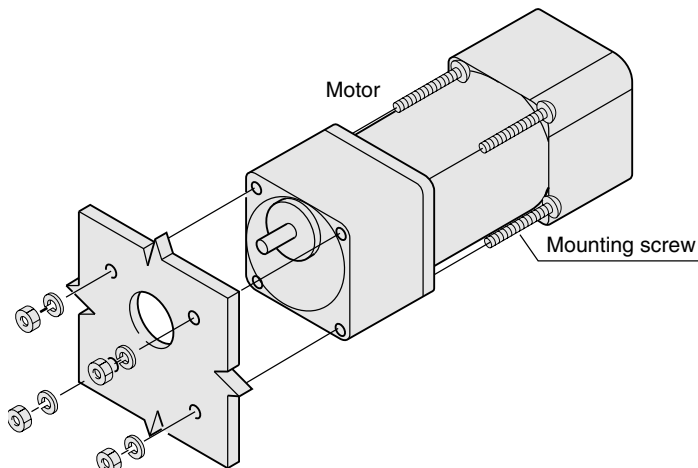

Right Angle Gearheads

Before mounting the right angle gearhead to machinery, assemble the motor and the gearhead using the screws provided.

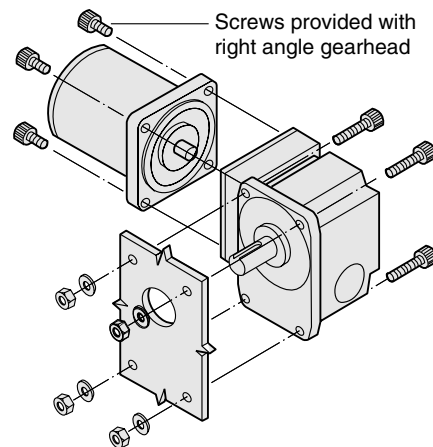

Mounting Decimal Gearhead to GN, GB and GU type Gearheads

Use the screws provided with the decimal gearhead and secure all the parts so that there are no gaps between the motor flange face and the recessed area of the decimal gearhead, or between the decimal gearhead and the gearhead's recessed area.

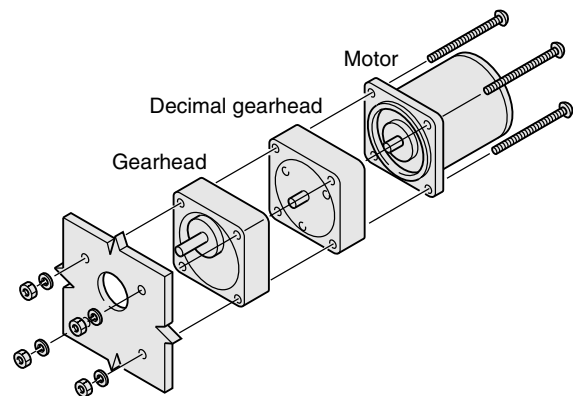

FBL II Series

The **FBL II** series is a gear motor in which the motor and gear head are pre-installed. Use the included installation screws to install on the device.

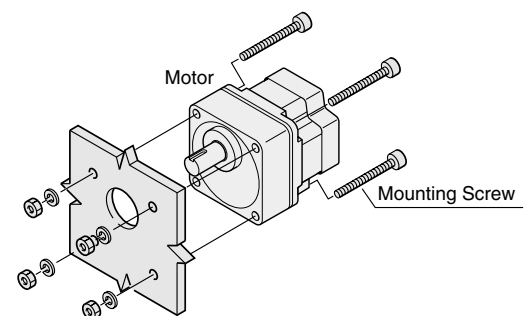

3. Dimensions of Mounting Holes

Each product's dimension drawing shows the mounting holes dimension with diametrical pitch. The distance between mounting holes is shown below.

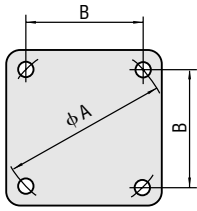

| Motor Frame Size | inch A (mm) | inch B (mm) |
|------------------|-------------|---------------|
| 1.65in. sq. | 1.89 (48) | 1.336 (33.94) |
| 2.36in. sq. | 2.76 (70) | 1.949 (49.50) |
| 2.76in. sq. | 3.23 (82) | 2.283 (57.98) |
| 3.15in. sq. | 3.70 (94) | 2.617 (66.47) |
| 3.54in. sq. | 4.09 (104) | 2.895 (73.54) |
| 4.09in. sq. | 4.72 (120) | 3.341 (84.85) |

4. Securing Load to Output Shaft

The output shafts of high power gearheads are provided with a key way to secure the load, while the shafts of gearheads with comparatively low power have been given a shaft flat. Round shaft motors come in two types, those with and without a shaft flat on the motor output shaft.

In round shaft types, the output shaft has a tolerance of ± 0.0002 inch (except 60W and 90W types) in diameter and is finished to a eccentricity of 0.0008 inch. Therefore, when connecting a load to the shaft, take measurements using a dial gauge or similar instrument. To couple to a shaft, use a helical coupling, to avoid unnecessary strain on the shaft. The same procedure applies when securing a load to gearheads.

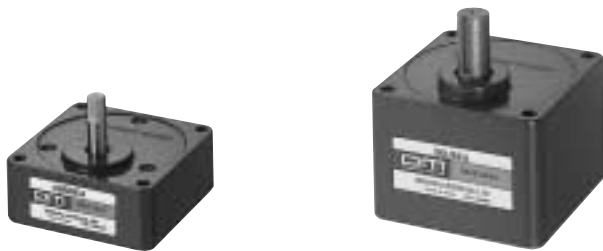

Shaft Flat

0GN, 2GN, 2GB, 3GN, 4GN, 4GB, 5GN Gearheads
Round shaft motors with frame size of 3.15in. sq. and 3.54in. sq.

Key Way

5GU, 5GC, 5GCH, BHI62□-□, BHI62□T-□, FBL575□W-□, FBL5120□W-□, HBL560N-□, HBL5100N-□ gearheads

Securing Load to Shaft Flat

With a shaft flat, use a locking screw to ensure that the load does not slip. We recommend using double point screws or other screws with strong locking power.

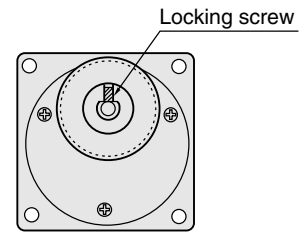

Securing Load Using Key Way

Secure loads using the key provided with the gearhead, fitting it into a key way.

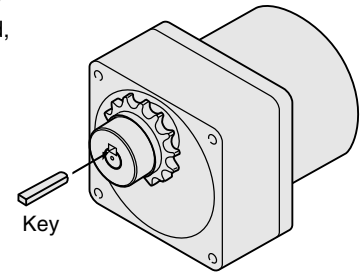

Note:

Ensure that the gearhead shaft is not subjected to shock in the axial direction, since this will have an adverse effect on the bearings. Be especially careful not to use a hammer when inserting the key.

5. Capacitor installation method

Unit = inch (mm)

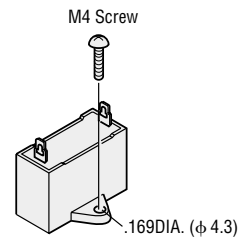

Install securely, using the screw shown on the drawing.

6. Screw Dimensions

GN type, GU type, GB type, GC type, BH Series, FBLII Series, HBL Series, FPW Series, Gearheads

The following screws are provided with the gearhead and decimal gearhead.

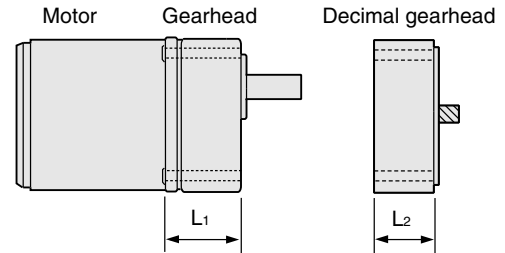
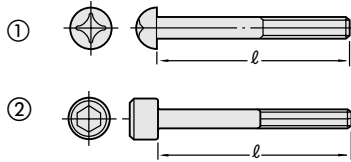

| Model | Gearhead | | Screws | | | | Drawing |
|---|----------|------|--------|-------|------|-----|---------------|
| | inch | mm | inch | mm | inch | mm | |
| 0GN3KA~180KA | 1.22 | 31 | — | — | 1.57 | 40 | No.4-40UNC |
| 2GN3KA~18KA | 1.46 | 37 | — | — | 1.97 | 50 | No.8-32UNC |
| 2GN25KA~180KA | 1.85 | 47 | — | — | 2.36 | 60 | |
| 3GN3KA~18KA | 1.54 | 39 | — | — | 1.97 | 50 | No.10-24UNC ① |
| 3GN25KA~180KA | 1.93 | 49 | — | — | 2.56 | 65 | |
| 4GN3KA~18KA | 1.54 | 39 | — | — | 1.97 | 50 | |
| 4GN25KA~180KA | 1.95 | 49.5 | — | — | 2.56 | 65 | |
| 5GN3KA~18KA | 1.95 | 49.5 | — | — | 2.76 | 70 | 1/4-20UNC |
| 5GN25KA~180KA | 2.66 | 67.5 | — | — | 3.27 | 83 | |
| 5GU3KA~180KA | 2.85 | 72.5 | — | — | 3.74 | 95 | |
| BHI62□-3.6~180, BHI62□T-3.6~180 | 3.27 | 83 | — | — | 3.94 | 100 | M8 P1.25 ② |
| 2GN10XK (Decimal Gearhead) | — | — | 2.87 | 73 | 3.35 | 85 | M4 P0.7 |
| 3GN10XK (Decimal Gearhead) | — | — | 3.11 | 79 | 3.54 | 90 | M5 P0.8 ① |
| 4GN10XK (Decimal Gearhead) | — | — | 3.21 | 81.5 | 3.74 | 95 | |
| 5GN10XK (Decimal Gearhead) | — | — | 4.11 | 104.5 | 4.72 | 120 | M6 P1.0 ② |
| 5GU10XKB (Decimal Gearhead) | — | — | 4.43 | 112.5 | 5.51 | 140 | |
| 2GB3KA~18K | 1.30 | 33 | — | — | 1.77 | 45 | M4 P0.7 |
| 2GB25KA~360KA | 1.65 | 42 | — | — | 1.97 | 50 | |
| 4GB3KA~18KA | 1.54 | 39 | — | — | 1.97 | 50 | M5 P0.8 ① |
| 4GB25KA~360KA | 1.95 | 49.5 | — | — | 2.56 | 65 | |
| 2GB10XK (Decimal Gearhead) | — | — | 2.68 | 68 | 3.35 | 85 | M4 P0.7 |
| 4GB10XK (Decimal Gearhead) | — | — | 3.21 | 81.5 | 3.74 | 95 | M5 P0.8 |
| FBL575□W-5~20, FBL5120□W-5~20 (Combination type) | 2.17 | 55 | — | — | 2.95 | 75 | M8P1.25 ② |
| FBL575□W-30~100, FBL5120□W-30~100 (Combination type) | 2.68 | 68 | — | — | 3.54 | 90 | |
| FBL575□W-200, FBL5120□W-200 (Combination type) | 2.91 | 74 | — | — | 3.74 | 95 | |
| HBL560N-5~20, HBL5100N-5~20 (Combination type) | 2.17 | 55 | — | — | 2.95 | 75 | |
| HBL560N-30~100, HBL5100N-30~100 (Combination type) | 2.68 | 68 | — | — | 3.54 | 90 | |
| HBL560N-200, HBL5100N-200 (Combination type) | 2.91 | 74 | — | — | 3.74 | 95 | |
| HBL425□-□ | 2.32 | 59 | — | — | 3.15 | 80 | M5 P0.8 |
| HBL540□-□ | 2.85 | 72.5 | — | — | 3.54 | 90 | M6 P1.0 |
| HBL560□-□ | 2.93 | 74.5 | — | — | 3.54 | 90 | |
| HBL690□-□ | 3.25 | 82.5 | — | — | 3.94 | 100 | |

● The figures of L₁+L₂ refer to sizes when a decimal gearhead and a gearhead with gear reduction ratio of 25:1 or greater are connected.

● 4 washers and 4 hexagonal nuts are provided with the screws.

● Stainless steel screws are provided with the **FPW** series washdown motors.

Right Angle Gearhead

To assemble the motor and gearhead, use the screws provided with the gearhead. To mount an additional decimal gearhead, use the screws provided with the decimal gearhead. To attach the gearhead to other devices, obtain the screws separately.

| Gearhead | Screws | | |
|------------------------|---|----------------|-----------------|
| | 4 Washers and 4 hexagonal nuts are provided | | |
| Model | ℓ inch (mm) | Size of Screws | Shape of Screws |
| 4GN □RAA•RH | 0.59 (15) | M5 P0.8 | ② |
| 5GN (U) □RAA•RH | 0.79 (20) | M6 P1.0 | ② |

Control circuit installation

1. Control circuit installation method

When installing the driver, speed control pack, control unit, and other control circuits in the device, use the fittings and screws that are provided. (DIN rail installation plates are also available as an option. For details, see Page A-271.)

Note:

When attaching the driver in an enclosed space such as a control box, or somewhere close to a heat-radiating object, vent holes should be used to prevent the drivers from overheating. If the ambient temperature listed in the installation conditions for the control circuit is exceeded, use forced-air cooling with a fan.

● FBL II Series*

Base Mounting

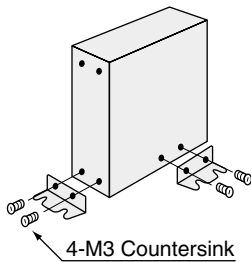

Back Mounting

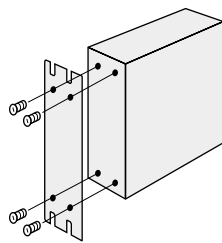

● HBL Series

Use M3 screws for mounting (not provided)

Base Mounting

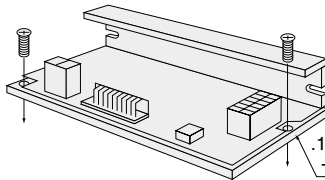

Back Mounting

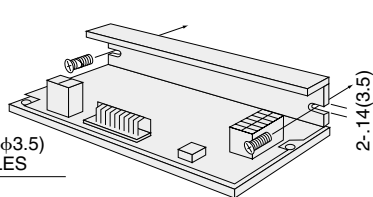

Unit = inch (mm)

* To improve ventilation, mount the speed control pack in an upright position as shown in the figures above.

● US Series Control Unit

Please see Page A-163.

2. Installation conditions

Install the driver, speed control pack and speed control unit in a location that meets the following conditions. Using the unit in a location that does not satisfy these conditions could cause damage.

- Indoors (this product is designed and manufactured to be installed within another device)
- Ambient temperature : Depends on the product, so see the appropriate page.
- Ambient humidity: 85% max. (avoid condensation)
- Not exposed to explosive, flammable or corrosive gas
- Not exposed to direct sunlight
- Not exposed to dust
- Not exposed to water or oil
- Place where heat can escape easily
- Not exposed to continuous vibration or excessive impact
- 328 feet (1000 meters) or less above sea level.
- Installation Category II , Pollution Degree 2, Class I (for EN60950)

3. Mounting Two or More Drivers

When mounting two or more drivers, separate them by a space of at least 0.79 inch (20mm). Leave at least 0.98 inch (25mm) between of space the driver and other devices or structures.

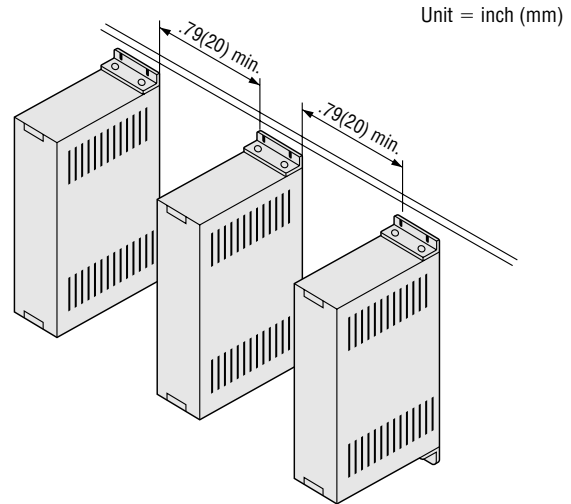

Motor Use

1. Power

Oriental Motor standard AC motors are available for single-phase 115VAC, single-phase 230VAC and three-phase 230VAC specifications. Capacitors must always be connected to single-phase motors.

2. Direction of Rotation

Clockwise (CW) and counterclockwise (CCW) direction of rotation, as referred to in the motor connection diagrams of this catalog, is defined as the direction of rotation when viewing the mounting face end of the motor. The direction of rotation of a gearhead used with the motor is determined by its design and, depending on the gear ratio, may be the same or the opposite of the direction of rotation of the motor. Changing the direction of rotation of the gearhead can be done by changing the direction of rotation of the motor.

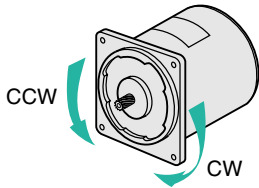

• Induction Motors

Change the direction of motor rotation only after the motor comes to a complete stop. If an attempt is made to change the direction of rotation while the motor is rotating, the motor may ignore the reversing command or change its direction of rotation after some delay.

Example

| Clockwise direction | Counterclockwise direction |
|---|---|
| Single-Phase 110/115VAC, 220/230VAC | Single-Phase 110/115VAC, 220/230VAC |
| Three-Phase 220/230VAC | Three-Phase 220/230VAC |

• Reversible Motors

The direction of rotation can be reversed during motor rotation using a switch. Moving the switch to CW causes the motor to rotate clockwise; moving the switch to CCW causes the motor to rotate counterclockwise.

Example

| Clockwise direction | Counterclockwise direction |
|---|---|
| Single-Phase 110/115VAC, 220/230VAC | Single-Phase 110/115VAC, 220/230VAC |

• Contact capacity

Connect a CR circuit (surge suppressor) like that in the drawing in order to protect the contacts.

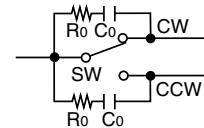

| Code | Contact capacity, others | Remarks |
|---------|--|---|
| SW | AC125V 5Amin.or AC250V 5Amin.(Induction load) | — |
| Ro · Co | Ro=5~200Ω Co=0.1~0.2μF 200W (400WV) | Accessories EPCR1201-2 A-272 |

3. Grounding

Lead Wire Type and Small Terminal Box Type

Any one of the four mounting bolts may be used to attach the ground wire to the motor casing when installing the unit. If necessary, remove all paint that may impede conductivity around the bolt mounting hole.



● **Terminal Box Type** (for 4IK, 4RK, 5IK, 5RK and BH types)

Connect the ground wire to the ground terminal inside the terminal box.

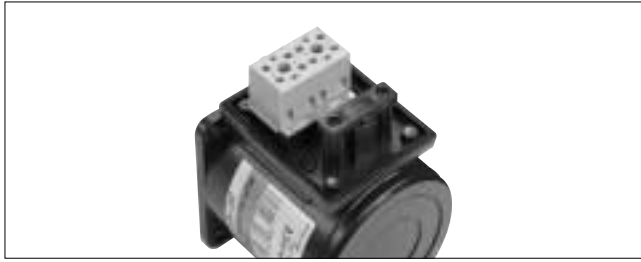

● **Conduit Box Type**

Conduit box mounted motors have a ground lead wire (green wire). Connect the ground wire to this green lead wire.

Single-Phase Motors
Conduit Box

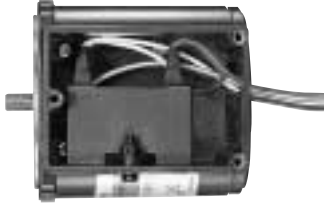

Three-Phase Motors
Conduit Box



4. Terminal Box

Induction motors and reversible motors are available with mounted terminal boxes for easy and secure connections of electrical wiring. They are suitable for automated and labor-saving applications where their ability to withstand rough operating conditions is essential, e.g. for machine tools and plant machinery.

● **Types of Terminal Boxes**

Depending on the motor model two types of terminal boxes are available: a small terminal box and a large terminal box, the latter being outfitted with a pressure sealing ring at the point of cord entry.

Small Terminal Box (for 2IK and 2RK types)

Light, compact and with in-line arrangement of terminals for ease of connection

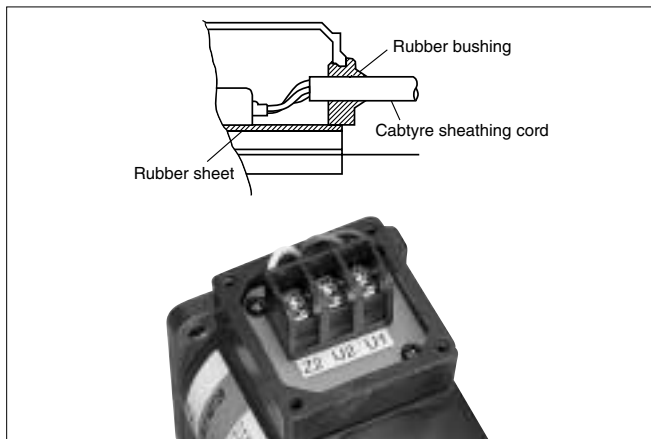

Terminal Box (for 4IK, 4RK, 5IK, 5RK and BH types)

A cable clamp and pressure sealing ring securely fasten the cable at two points.

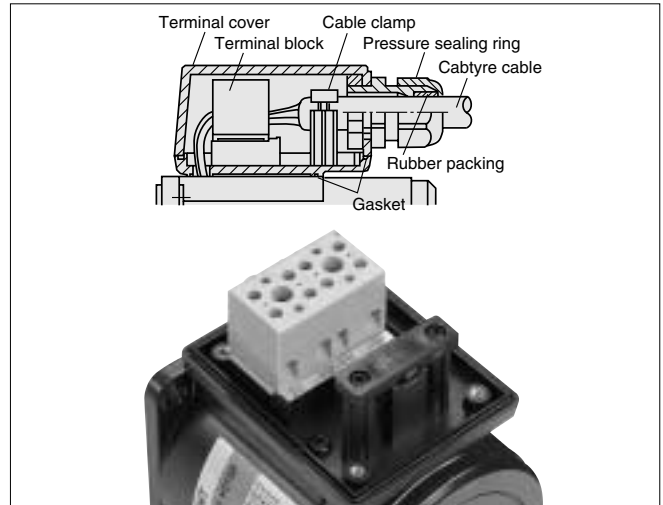

The material of the terminal box is a PBT resin with excellent insulation performance. The terminal block has met safety standards and been recognized or certified by major certification bodies.

When connecting cables to the terminal block, unfasten the screw of the connector and insert the lead wire with a screw driver. Then insert the lead wire to the insert port and refasten the screw securely.

Diameter of the suitable cabtyre cable: .24DIA. (φ 6mm)
~.47DIA. (φ 12mm)

Lead wires specifications

Thickness : AWG 24~12

Length of strip : .31 inch (8mm)

The terminal box cover uses a PBT resin with excellent insulation performance.

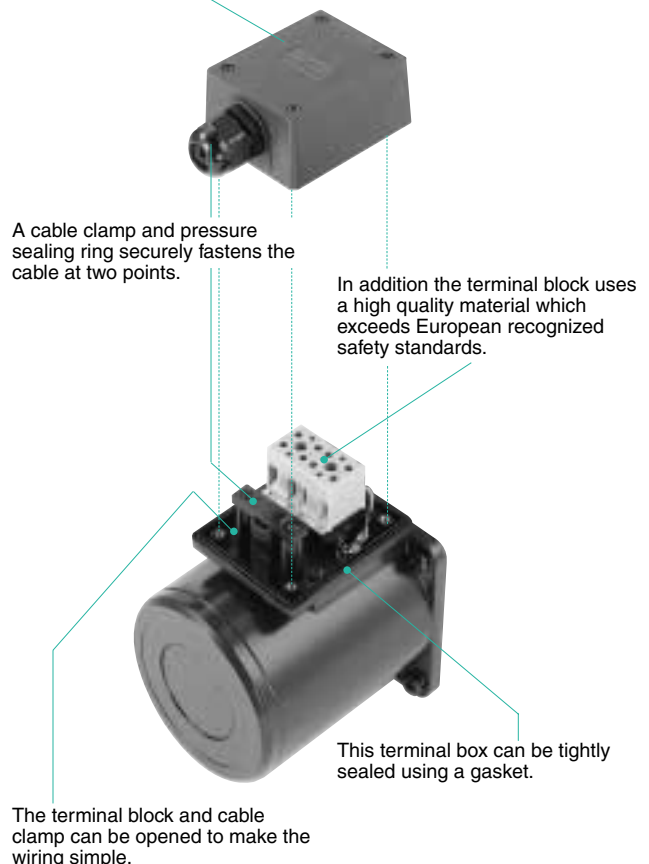

5. Capacitor

Capacitor motors are wound so that the axis of the primary coil and the secondary coil poles are 90° apart. The capacitor is connected in series to the secondary coil and its function is to advance the phase of the current flowing in the secondary coil. The motors employ vapor-deposition polar capacitors which are UL recognized models. These capacitors have elements created on paper or plastic film through metal vapor deposition and can repair themselves, so they are commonly dubbed SH (self-healing) capacitors. Paper elements used to be the most common, but in recent years miniaturization of capacitors has made plastic film elements the dominant type.

Our single-phase motors are capacitor motors. When using a capacitor with the motor, make sure that the rated capacitance and voltage as indicated on the capacitor correspond to the specifications on the motor and that all electrical connections are correct.

Capacitance

If a capacitor of the wrong value is used, motor vibration and heat generation will become abnormally large and operation will become unstable due to a loss of torque. For this reason, always use a capacitor of the correct capacitance. Capacitance is indicated by the unit of microfarads (μF).

Rated Voltage

Using the motor beyond the rated voltage can drastically shorten the operating life of the capacitor. Always use a capacitor of proper voltage ratings. The voltage rating of the capacitor is indicated in the unit of Volts (VAC).

● Connecting the Capacitor

2-terminal type

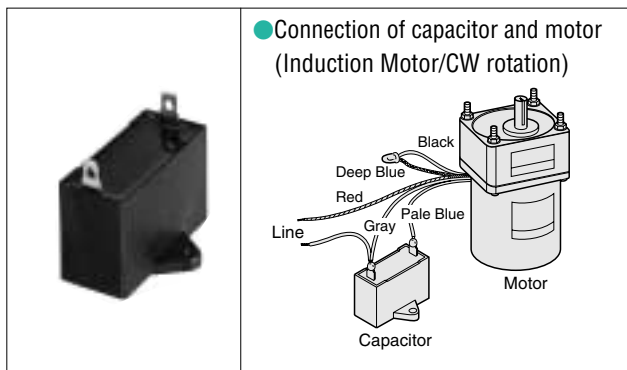

4-terminal type

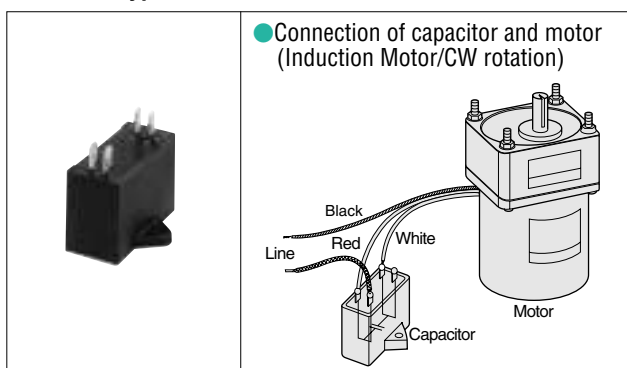

● Installing the Capacitor

Unit = inch (mm)

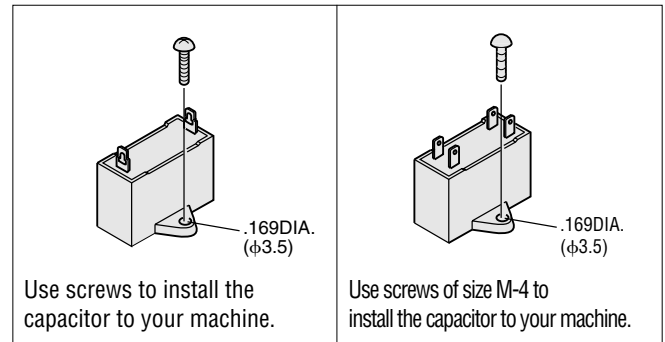

Note: When motors are running, a voltage of twice the motor power supply voltage is applied across the terminals of the capacitor. The terminals must therefore be insulated to ensure safety.

6. Ambient Temperature and Temperature Rise in Motor

The ambient temperature and the rise of the motor temperature are limiting parameters for the suitability of a motor in a given application.

Ambient Temperature

Use motors at ambient temperatures between 14°F(-10°C) and 104°F(+40°C) Part of motor : between 14°F(-10°C) and 122°F(+50°C). When used at temperatures outside of this range, an additional rise in temperature caused by motor operation may lead to deterioration of the winding insulation of the motor or may drastically shorten the operating life of the ball bearings. Low ambient temperatures result in problems primarily with starting characteristics. Inner friction of the motor increases with the decrease in viscosity of gearhead and ball bearing lubricants resulting in a slower ramp up of the motor or failure of the motor to start.

Temperature Rise in Motor

When a motor is operating, all energy losses of the motor are transformed into heat, causing the motor temperature to rise.

● Induction Motors

The induction motor, which is rated for continuous duty, reaches the saturation point of temperature rise after two or three hours of operation, whereupon the temperature stabilizes.

● Reversible Motors

Reversible motors reach their limit for temperature rise after 30 minutes of operation. If operation continues beyond that normal temperature rise, it may lead to damage or shortened life of the motor.

Measuring the Temperature Rise

The following is a description of the methods Oriental Motor uses for temperature measurement and for the determination of the maximum allowable temperature rise of a motor.

● Thermometer Method

The temperature at which the temperature rise during motor operation becomes saturated is measured using a thermometer or thermocouple attached to the center of the motor case. The temperature rise is defined as the difference between the ambient temperature and the measured temperature.

● Resistance Change Method

In this method, the coil resistance is measured before running and again after a period of running. The measurement should be taken at the point of maximum temperature rise.

The point of the highest motor temperature rise is the windings. For this reason, the maximum allowable temperature of the windings is the one stated in the EN/IEC, UL, CSA standards for the given type of insulation materials. Some Oriental Motor motors employ Class B insulation. According to EN/IEC, UL, CSA standards, the temperature of the windings is 266°F(+130°C). Note that if the motor is started and stopped frequently, if the direction of motor rotation is frequently changed, or if the motor is frequently brought to an instantaneous stop using an electromagnetic brake or similar mechanism, the temperature of the motor may rise more than that of normal operation. The lower the temperature, the longer the life of the motor. Some of the motors are equipped with a thermal protector as overheat protection.

Some of the motors have Type E insulation (248°F[+120°C]) or Type A insulation (221°F[+105°C]).

Although the motor case may become very hot while the motor is in operation, in some case as high as 200°F (+93°C), this does not indicate a malfunction. Take precautions against heat before touching the motor, and avoid accidents by keeping flammable materials away from the motor.

7. Permissible Overhung Load and Permissible Thrust Load

Thrust load and overhung load exceeding the permitted values invite short-term fatigue on the bearings and breakdown due to the repeated load on the output shaft.

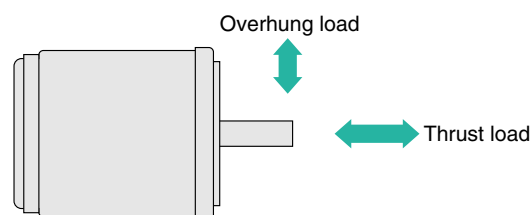

Operate so that the overhung load does not exceed the permitted values in the table below. When a chain, belt, etc. is used as the transmission mechanism, the method for calculating the load on the output shaft is the same as for a gear head output shaft. For details, see Page A-22.

Also, avoid thrust loads as much as possible. If thrust load is unavoidable, keep it to no more than half the motor weight.

■ Permissible Overhung Load on the Motor Shaft

● AC Motor

| Motor | | Permissible Overhung Load lb.(N) | | | | |
|------------------------------|------------------------------|----------------------------------|----------------------------------|-------|----------------------------------|-------|
| Motor Frame Size inch(mm) | Motor Shaft Size inch(mm) | Series | 0.4 inch(10mm) from shaft end | | 0.8 inch(20mm) from shaft end | |
| 1.64 (42) sq. | .1969DIA. (φ 5) | K | 8.8 | (40) | — | — |
| 2.36 (60) sq. | .2500DIA. (φ 6.35) | J | 11 | (50) | 24.3 | (110) |
| | | K | 11 | (50) | 24.3 | (110) |
| 2.76 (70) sq. | .2500DIA. (φ 6.35) | J | 8.8 | (40) | 13.2 | (60) |
| | | K | 8.8 | (40) | 13.2 | (60) |
| 3.15 (80) sq. | .3125DIA. (φ 7.937) | J | 19.8 | (90) | 30.9 | (140) |
| | | K | 19.8 | (90) | 30.9 | (140) |
| 3.54 (90) sq. | .3750DIA. (φ 9.525) | K(with fan) | 30.9 | (140) | 44.1 | (200) |
| | | | .4724DIA. (φ 12) | 52.9 | (240) | 59.5 |
| 4.09 (104) sq. | .5512DIA. (φ 14) | BH | 70.5 | (320) | 77.2 | (350) |

● Brushless DC Motor

| Motor | | | Permissible Overhung Load lb.(N) | | | |
|------------------------------|------------------------------|------------------|----------------------------------|-------|----------------------------------|-------|
| Motor Frame Size inch(mm) | Motor Shaft Size inch(mm) | Series | 0.4 inch(10mm) from shaft end | | 0.8 inch(20mm) from shaft end | |
| 2.36 (60) sq. | .2362DIA.(φ 6) | HBL | 17.6 | (80) | 19.8 | (90) |
| 3.15 (80) sq. | .3150DIA.(φ 8) | HBL | 17.6 | (80) | 24.3 | (110) |
| | | HBL (40W) | 26.5 | (120) | 30.9 | (140) |
| | | HBL (60W) | 28.7 | (130) | 33.1 | (150) |
| 3.54 (90) sq. | .3937DIA.(φ 10) | FBL II | 28.7 | (130) | 33.1 | (150) |
| | | HBL | 35.3 | (160) | 37.5 | (170) |
| | | FBL II | 35.3 | (160) | 37.5 | (170) |
| | .4724DIA.(φ 12) | | | | | |

Using Gearheads

Oriental Motor gearheads are specifically designed for easy and direct attachment to AC motors with a pinion shaft. With the reduction of the motor speed through the gearhead, an increase of torque is achieved. A large number of gear ratios are available for many applications.

1. Types of Gearhead

These gearheads listed below are all low noise types. Motors that can be used with these gearheads have a helical cut spline on the shaft that mates with the first stage of gears in the gearhead. This helical gear mating with the first stage, which is the primary source of noise in a gearhead, along with a redesigned gearcase and ball bearings, reduces noise by 7 to 10 dB.

Depending on the motor type and output power, the following gearheads are available.

| Application | Gearheads | Decimal Gearheads |
|------------------------------|----------------------------|-------------------|
| light load | 2GB□KA | 2GB10XK |
| | 4GB□KA | 4GB10XK |
| normal load | 0GN□KA | — |
| | 2GN□KA | 2GN10XK |
| | 3GN□KA | 3GN10XK |
| | 4GN□KA | 4GN10XK |
| | 5GN□KA | 5GN10XK |
| heavy load | 5GU□KA | 5GU10XKB |
| | BHI62F-□, BHI62□T-□ | — |
| impact load | 5GC□KA | — |
| | 5GCH□KA | — |
| | FBL575□W-□ | — |
| heavy and/or high speed load | FBL5120□W-□ | — |
| | HBL560N-□ | — |
| | HBL5100N-□ | — |

The box (□) in the model number represents the desired gear ratio, which thereby becomes part of the code for the gearhead.

● Connection Procedures

When connecting gearheads, be sure to match the pinion shafts and frame sizes.



● Decimal Gearheads

The **GB**, **GN** and **GU** type gearheads are also available as gear decimal gearheads (sold separately) with a gear ratio of 10:1. They should be used in applications in which large gear ratios cannot be attained with a single gearhead unit. Any number of decimal gearheads can be used in series.

Note

Although the gear ratio of 10:1 of the decimal gearhead theoretically translates into a 10 time increase of torque available on the output shaft, it is not possible to make full use of this torque. The torque permissible in actual use is limited by the physical construction of the gearhead and is expressed as its rated maximum torque. (See the torque table of each product)



● Right-Angle Gearheads

The **4GN**, **5GN** and **5GU** type gearheads are also available as right-angle gearheads.

| Type | Model | Motor Output Power |
|--------------|----------------|--------------------|
| Hollow shaft | 4GN□RH | 25W |
| | 5GN□RH | 40W |
| | 5GU□RH | 60 · 90W |
| Solid shaft | 4GN□RAA | 25W |
| | 5GN□RAA | 40W |
| | 5GU□RAA | 60 · 90W |

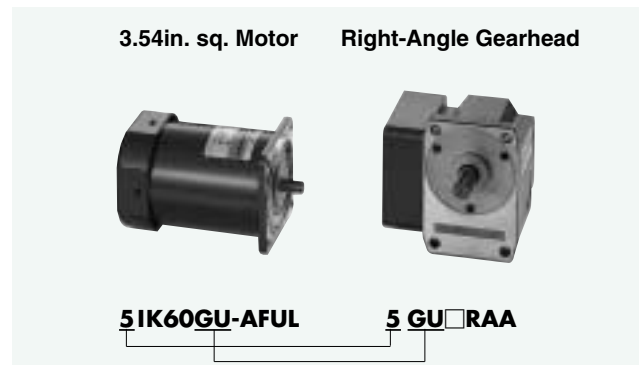

2. Speed and Direction of Rotation

The speed when a gearhead is directly coupled to a motor is calculated according to the following formula:

$$N_G = \frac{N_M}{i}$$

N_G : Speed of Gearhead [r/min]

N_M : Speed of motor [r/min]

i : Gear ratio of gearhead

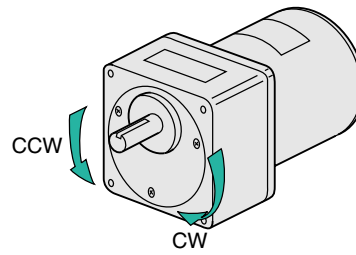

- Same direction as the motor shaft
- Opposite direction as the motor shaft

The direction of gearhead shaft rotation may differ from motor shaft rotation depending on the reduction ratio of the gearhead.

| Gearhead Model \ Gear Ratio | 3 | 3.6 | 5 | 6 | 7.5 | 9 | 12.5 | 15 | 18 | 25 | 30 | 36 | 50 | 60 | 75 | 90 | 100 | 120 | 150 | 180 | 250 | 300 | 360 | |
|---------------------------------------|---|-----|---|---|-----|---|------|----|----|----|----|----|----|----|----|----|-----|-----|-----|-----|-----|-----|-----|--|
| 2GN□KA, 3GN□KA, 4GN□KA, 5GN□KA | | | | | | | | | | | | | | | | | | | | | | | | |
| 2GB□KA, 4GB□KA | | | | | | | | | | | | | | | | | | | | | | | | |
| 0GN□KA, 5GU□KA | | | | | | | | | | | | | | | | | | | | | | | | |
| BHI62□-□ | | | | | | | | | | | | | | | | | | | | | | | | |

Connection of a decimal gearhead reduces the speed by 10 : 1 but does not affect the direction of rotation.

| Gearhead Model \ Gear Ratio | 5 | 10 | 15 | 20 | 30 | 50 | 100 | 200 |
|--------------------------------|---|----|----|----|----|----|-----|-----|
| FBL575□W-□, FBL5120□W-□ | | | | | | | | |
| HBL560N-□, HBL5100N-□ | | | | | | | | |

3. Output Torque of Gearmotor

The output torque when a gearhead is directly connected is calculated as follows:

$$T_G = T_M \times i \times \eta$$

T_G : Output Torque at Gear Shaft [oz-in]

T_M : Motor Torque [oz-in]

i : Gear Ratio of Gearhead

η : Gearhead Efficiency

• Gearhead Efficiency

| Gearhead Model \ Gear Ratio | 3 | 3.6 | 5 | 6 | 7.5 | 9 | 12.5 | 15 | 18 | 25 | 30 | 36 | 50 | 60 | 75 | 90 | 100 | 120 | 150 | 180 | 250 | 300 | 360 | |
|---------------------------------------|-----|-----|-----|-----|-----|-----|------|----|----|-----|----|----|-----|----|----|-----|-----|-----|-----|-----|-----|-----|-----|--|
| 2GN□KA, 3GN□KA, 4GN□KA, 5GN□KA | 81% | | | | | | 73% | | | | | | 66% | | | | | | | | | | | |
| 2GB□KA, 4GB□KA | 81% | | | | | | 73% | | | | | | 66% | | | | | | 59% | | | | | |
| 0GN□KA, 5GU□KA | 81% | | | | | | 73% | | | | | | 66% | | | | | | 59% | | | | | |
| BHI62F-□, BHI62□T-□ | 90% | 90% | 90% | 90% | 90% | 90% | 86% | | | 86% | | | 81% | | | 81% | | | 81% | | | 81% | | |

Gearhead efficiency of all the decimal gearheads is 81%.

| Gearhead Model \ Gear Ratio | 5 | 10 | 15 | 20 | 30 | 50 | 100 | 200 |
|--------------------------------|-----|----|----|----|-----|----|-----|-----|
| FBL575□W-□, FBL5120□W-□ | 90% | | | | 86% | | | 81% |
| HBL560N-□, HBL5100N-□ | 90% | | | | 86% | | | 81% |

● **Maximum Permissible Torque**

Since the output torque of the gearhead increases proportionally with the reduction of speed, a high gear ratio will result in an output torque that cannot be handled by physical construction of the gearhead. The maximum permissible torque of the gearhead and the speed-reduction ratio is as follows:

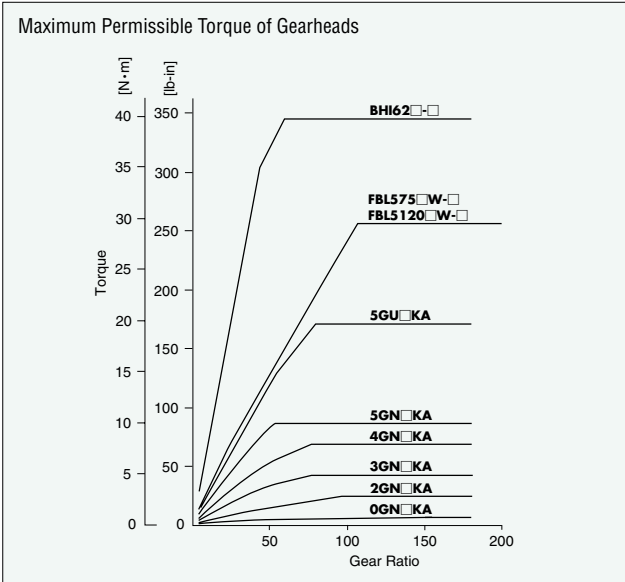

Example: If induction motor **4IK25GN-AWU** is combined with gearhead **4GN100KA**, the output torque is...
The rated torque of motor **4IK25GN-AWU** is 23.6 oz-in.
The gearhead output torque is calculated using the equation on the previous page.

$$\begin{aligned} \text{Output torque } T_G &= T_M \times i \times \eta \\ &= 23.6 \times 100 \times 0.66 \\ &= 1558 \text{ oz-in } (\doteq 97.4 \text{ lb-in}) \end{aligned}$$

The maximum permissible torque for **4GN100KA** is 69 lb-in as shown in the diagram above. Therefore, the load torque that can be exerted is only 69 lb-in even if the gearhead has theoretical output torque is 94 lb-in.

4. Permissible Load Inertia for Gearheads

When a high load inertia (J) is connected to a gearhead, high torques are exerted instantaneously on the gearhead when starting up in frequent, discontinuous operations (or when stopped by an electromagnetic brake).

Excessive impact loads can be the cause of gearhead or motor damage.

The table shown below gives values for permissible inertial load on the motor shaft. Use the motor and gearhead within these parameters.

The permissible inertial load value shown for three-phase motors is the value when reversing after a stop.

The permissible J on the gearhead output shaft is calculated with the following equation. The life of the gearhead when operating at the permissible inertial load with instantaneous stops of the motors with electromagnetic brakes is at least 2 million cycles.

● **Permissible Inertia Load**

Gear ratio 1/3~1/50 $J_G = J_M \times i^2$

Gear ratio 1/60 or higher $J_G = J_M \times 2500$

J_G : Permissible Inertia Load (oz-in²) on the gearhead output shaft

J_M : Permissible Inertia Load (oz-in²) on the motor shaft

i : Gear ratio (Example : $i = 3$ means the gear ratio of 1/3)

Permissible Load Inertia on the motor shaft

AC Motor

| No. of Phase | Frame Size inch (mm) | Output Power (W) | Permissible Inertial Load |
|----------------|-------------------------|---------------------|--|
| | | | at Motor Shaft oz-in ² (×10 ⁻⁴ kgm ²) |
| Single-Phase | 1.64 (42) sq. | 1W | 0.088 (0.016) |
| | | 3W, 4W | 0.26 (0.047) |
| | 2.36 (60) sq. | 6W | 0.34 (0.062) |
| | | 10W | 0.56 (0.10) |
| | 2.76 (70) sq. | 15W | 0.78 (0.14) |
| | | 15W, 20W | 1.2 (0.22) |
| | 3.15 (80) sq. | 25W | 1.6 (0.31) |
| | | 40W | 4.0 (0.75) |
| | 3.54 (90) sq. | 60W | 6.2 (1.1) |
| | | 90W | 6.2 (1.1) |
| 4.09 (104) sq. | 200W | 11 (2.0) | |
| Three-Phase | 3.15 (80) sq. | 25W | 1.6 (0.31) |
| | | 40W | 4.0 (0.75) |
| | 3.54 (90) sq. | 60W | 6.2 (1.1) |
| | | 90W | 6.2 (1.1) |
| | 40.9 (104) sq. | 200W | 11 (2.0) |

Brushless DC Motor

| Series | Frame Size inch (mm) | Output Power (W) | Permissible Inertial Load |
|---------------------|-------------------------|---------------------|--|
| | | | at Motor Shaft oz-in ² (×10 ⁻⁴ kgm ²) |
| FBLII Series | 3.54 (90) sq. | 75W | 5.4 (1.0) |
| | | 120W | 5.4 (1.0) |
| | 2.36 (60) sq. | 10W | 0.34 (0.062) |
| HBL Series | 3.15 (80) sq. | 25W | 1.2 (0.22) |
| | 3.54 (90) sq. | 40W | 2.1 (0.40) |
| | | 60W | 5.4 (1.0) |
| | | 100W | 5.4 (1.0) |

5. Service Life of Gearhead

Gearhead life is almost completely determined by bearing life. When gearheads are operated under the following conditions, the life of the gearheads is approximately 5000 hours for ball bearing types. This is termed "rated life".

- Torque: Rated Torque
- Load: Uniform and continuous
- Operating time: 8 hours per day
- Case temperature: 176°F(80°C) (Ball bearing type)

However, there is usually some fluctuation in load. To evaluate gearhead life expectancies, a "service factor" is used.

Service Factor

| Type of Load | Service Factor | | |
|---------------|--------------------------|-------------|--------------|
| | 5 hours/day Intermittent | 8 hours/day | 24 hours/day |
| Uniform | 0.8 | 1.0 | 1.5 |
| Light impact | 1.2 | 1.5 | 2.0 |
| Medium impact | 1.5 | 2.0 | 2.5 |

Example of Load

| Type of Load | Example of Load |
|---------------|--|
| Uniform | Belt conveyor, Uni-directional operation |
| Light impact | Frequent start/stop, Cam drive |
| Medium impact | Frequent CW/CCW operation, Frequent instantaneous stop |

A gearhead under continuous operation for eight hours per day under a uniform load has been given the reference service factor of 1.0. The life of the gearhead when operated within the limit for permissible torque is then 5000 hours for a ball bearing type gearhead. (Temperature of gearhead casing not exceeding 176°F[80°C].)

However, when such a gearhead is operated continuously for 24 hours a day, the service factor rises to 1.5. With an identical load torque, the life of the motor will be reduced to 1/1.5 of the original life expectancy. For example, if a life of 5000 hours is required for a **4GN□KA** type gearhead, it must be operated with 2/3 or less of the torque for 8-hour operation, or a gearhead with a larger permissible torque must be used.

6. Permissible Overhung Load and Permissible Thrust Load

"Overhung load" refers to load placed on the output shaft as shown in the figure below. The "thrust load" is a load applied in the axial direction of the output shaft. Since the overhung load and thrust load have a great influence on the life of the bearings and strength of the shaft, be careful not to exceed the maximum values shown in the chart below.

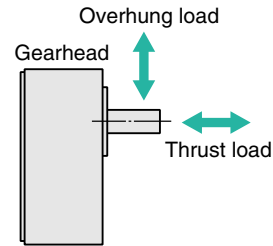

$$W = \frac{K \times T \times f}{\gamma}$$

W : Overhung Load [lb]

K : Load Coefficient for Driving Method (See table below)

T : Torque at Gearhead Output Shaft [lb-in]

f : Service Factor

γ : Effective Radius of Gear or Pulleys [in]

| Drive System | K |
|-----------------------|------|
| Chain or toothed belt | 1 |
| Gear | 1.25 |
| V-belt | 1.5 |
| Flat belt | 2.5 |

Take precautions so that the overhung load as calculated by the above equation does not exceed the permissible values given in the table to the right. If the overhung load greatly exceeds the permissible value, it will lead to the shortening of bearing life or damage to the bearing, as well as warping or breaking the output shaft after continued heavy load. In such situations, a support such as the one shown below must be designed to take up the overhung load.

Since connecting a transmission mechanism directly to the output shaft exerts an unbalanced load on the shaft, connect mechanisms as close to the gearhead as possible.

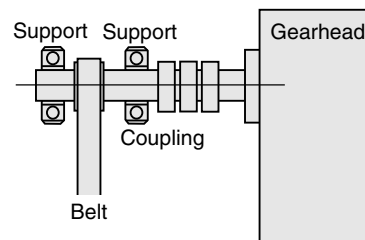

Permissible Overhung Load and Permissible Thrust Load

| Gearhead Mode | Gear Ratio | Maximum Permissible Torque lb-in (N-m) | Permissible Overhung Load lb.(N) | | Permissible Thrust Load lb.(N) |
|--------------------|---|---|-----------------------------------|-------------------------------------|-----------------------------------|
| | | | 0.4 inch(10mm) from shaft end | 0.8 inch(20mm) from shaft end | |
| 0GN□KA | 3~180 | 8.7 (1.0) | 4.4 (20) | — | 3.3 (15) |
| 2GB□KA | 3~360 | 13 (1.5) | 8.8 (40) | 13 (60) | 6.6 (30) |
| 2GN□KA | 3~18 25~180 | 26 (3.0) | 11 (50) 26 (120) | 18 (80) 40 (180) | 6.6 (30) |
| 3GN□KA | 3~18 25~180 | 43 (5.0) | 18 (80) 33 (150) | 26 (120) 55 (250) | 8.8 (40) |
| 4GB□KA | 3~18 25~360 | 43 (5.0) | 18 (80) 33 (150) | 26 (120) 55 (250) | 11 (50) |
| 4GN□KA | 3~18 25~180 | 69 (8.0) | 22 (100) 44 (200) | 33 (150) 66 (300) | 11 (50) |
| 5GN□KA | 3~18 25~180 | 87 (10) | 55 (250) 66 (300) | 77 (350) 99 (450) | 22 (100) |
| 5GU□KA | 3~9 12.5~18 25~180 | 174 (20) | 88 (400) 99 (450) 110 (500) | 110 (500) 132 (600) 154 (700) | 33 (150) |
| BHI62F-□ | 3.6~9 | 347 (40) | 121 (550) | 176 (800) | 44 (200) |
| BHI62□T-□ | 12.5~180 | | 143 (650) | 220 (1000) | |
| 5GC□KA | 3.6~18 30~180 | 87 (10) | 55 (250) 66 (300) | 77 (350) 99 (450) | 22 (100) |
| 5GCH□KA | 3.6~9 15~18 30~180 | 174 (20) | 88 (400) 99 (450) 110 (500) | 110 (500) 132 (600) 154 (700) | 33 (150) |
| FBL575□W-□ | 5 | 260 (30) | 66 (300) | 88 (400) | 33 (150) |
| FBL5120□W-□ | 10~20 | | 8 (400) | 110 (500) | |
| | 30~200 | | 110 (500) | 143 (650) | |
| HBL560□-N | 5 | 260 (30) | 66 (300) | 88 (400) | 33 (150) |
| HBL5100□-N | 10~20 | | 88 (400) | 110 (500) | |
| | 30~200 | | 110 (500) | 143 (650) | |
| 4GN□RAA | 3.6~18 30~180 | 69 (8.0) | 22 (100) 44 (200) | 33 (150) 66 (300) | 22 (100) |
| 5GN□RAA | 3~18 25~180 | 87 (10) | 55 (250) 66 (300) | 77 (350) 99 (450) | 44 (200) |
| 5GU□RAA | 3~9 12.5~25 30~180 | 174 (20) | 88 (400) 99 (450) 110 (500) | 110 (500) 132 (600) 154 (700) | 55 (250) |
| FPW425_-□ | 3.6~18 30~180 | 69 (8.0) | 22 (100) 44 (200) | 33 (150) 66 (300) | 11 (50) |
| FPW540_-□ | 3.6~18 30~180 | 87 (10) | 55 (250) 66 (300) | 77 (350) 99 (450) | 22 (100) |
| FPW560_-□ | 3.6~9 15~18 30~180 | 130 (15) | 88 (400) 99 (450) 110 (500) | 110 (500) 132 (600) 154 (700) | 33 (150) |
| FPW690_-□ | 3.6~9 15~180 | 260 (30) | 121 (550) 143 (650) | 176 (800) 220 (1000) | 44 (200) |

See page [A-217] for Right-Angle gearhead **RH** type

Note: Permissible torque varies with the gear ratio. Do not exceed the maximum value.

When using transmission mechanisms involving helical gears or worm gears, they are subject not only to overhung load but to thrust load as well. Ensure that thrust load does not exceed the permissible levels given in the above table.

General Information

■ Construction and Material of AC Motors

The following figure shows the construction of a standard AC motor.

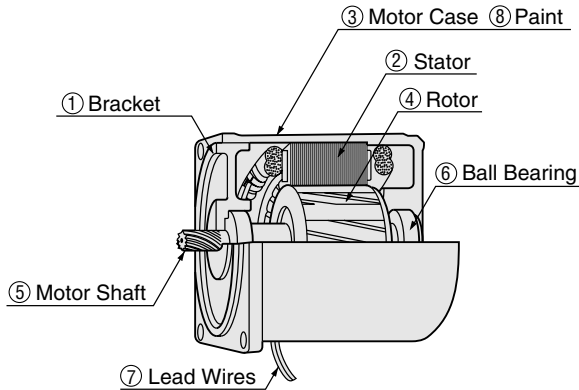

- ① **Bracket:** Die cast aluminum bracket with cut-finish. Press-fitted into the motor case.
- ② **Stator:** Comprised of stator core made from laminated silicon steel plate, a polyester-coated copper coil and insulation film.
- ③ **Motor Case:** Die cast aluminum with cut-finish inside.
- ④ **Rotor:** Laminated silicon steel plate with die cast aluminum .
- ⑤ **Shaft:** Available in round shaft and pinion shaft type. The metal used in shaft is S45C(carbon steel). Round shafts receive a shaft flat (output power of 25W or more), while pinion shafts undergo precision gear finishing.
- ⑥ **Ball Bearing:** Sealed ball bearings with long-life grease.
- ⑦ **Lead Wire:** Lead wires with heat-resistant polyethylene coating.
- ⑧ **Painting:** Baked finish of acrylic resin or melamine resin.



■ Handling

When handling motor during test or installation, hold the body of the motor so that the output shaft points upward. Also, when the unit is removed from the package for installation and placed in shelves, it is safer to place the motor upright with the shaft pointing upwards so that it cannot strike other motors. The lead wires are insulated and securely fixed to the stator and the case mechanically. They can, therefore, withstand a certain degree of tension applied to them. However, lifting the unit by the lead wires may cause them to break, or may damage the insulation or result in some other potentially hazardous situation.

■ Storage

Temperature and humidity are important considerations if the motor is to be stored for an extended period of time. Storage in places where there are large temperature and humidity variations will reduce the stator's insulation performance. Moreover, leaving the motor for extended periods in places with high temperature and humidity is likely to lead to corrosion. When storing for long periods, it is therefore recommended to coat the output shaft with an anti-corrosion agent, seal the motor in a polyethylene bag and store in a place with normal temperature and humidity.

AWG (Lead Wire Gage)

“AWG” is an abbreviation for “American Wiring Gage.” The AWG standards stipulate the core construction and conductor cross-sectional area of lead wires as AWG numbers. The larger the AWG number, the smaller the cross-sectional area. When the lead wire is also UL listed, it is further distinguished by a number called the “UL Style”. The AWG number is shown on the motor's external appearance drawing.

| AWG No. | Conductor Cross-Section(mm) |
|---------|-----------------------------|
| 26 | 0.128 |
| 24 | 0.205 |
| 22 | 0.325 |
| 20 | 0.519 |

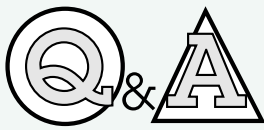

for Standard AC Motors

Q1. I may have to put the motor in an environment of 0°F to – 20°F during transport. Will this create a problem?

A1. Extreme changes in temperature may lead to condensation within the motor. Should this occur, parts may rust, greatly shortening the service life. Take measures to prevent condensation.

Q2. Can the motors be shipped through tropical climates?

A2. No. When the humidity and temperature differences within the cargo space of ships and airplanes are severe, the insulation may deteriorate due to condensation. Successful countermeasures are to ship the motors packed in sealed containers or bags containing de-oxygenating material.

Q3. The motor gets extremely hot. Is this all right?

A3. The internal loss generated when the motor converts electrical energy to rotational movement becomes heat, making the motor hot. The motor temperature is expressed as the ambient temperature plus the temperature rise caused by loss within the motor. If internal loss within the motor is 90°F (32°C) and the ambient temperature is 85°F, the surface of the motor will be 175°F (79°C). This is not abnormal for a small motor.

Q4. Will large fluctuations in power supply voltage affect the motor?

A4. The torque produced by the motor is affected by changes in power supply voltage. The torque the motor produces is proportional to roughly twice the power supply voltage. For example, if the voltage of a motor rated at 115 VAC fluctuates between 103.5 VAC (90%) and 126.5 VAC (110%), the torque produced will vary between 80% and 120%. When using motors under large power voltage fluctuations, remember that the torque produced will vary, so select a motor that provides a sufficient margin.

Q5. Can a reversible motor be used as an induction motor if the brake shoe is removed?

A5. A reversible motor is not simply an induction motor with a simple braking mechanism added. The ratio of coils between the primary coil and the secondary coils in a reversible motor is different from that of an induction motor. The simple brake mechanism is added to the rear of the motor. The capacitor capacity is also increased to increase starting torque. This means that if only the brake mechanism is removed, the reversible motor will not be usable at a continuous rating like an induction motor; it will simply lose its holding power and its reversing characteristics will be reduced.

Q6. What does it mean to say that a reversible motor is rated for 30 minutes?

A6. Reversible motors require a larger input power than induction motors to increase the starting torque and improve the instant reversing characteristics. This means that loss is high and the temperature rises more during continuous operation. If operated continuously, the motor will burn out. It is thus designed to provide maximum performance if operated for no more than 30 minutes continuously.

Q7. Can the speed of induction motors and reversible motors be changed?

A7. The speed of single-phase (AC) induction and reversible motors is determined by the power supply frequency. To change the speed of induction and reversible motors, the power supply frequency can be changed using inverter control or gears and pulleys. If your application requires changing speed, we recommend a speed control motor.

Q8. I want to run an induction motor in forward and reverse directions. Can I use the same wiring as a reversible motor?

A8. Induction motors are designed to be optimal for continuous operation in one direction. They are not suitable for instant forward/reverse operation. The problem that occurs when the same wiring is used to reverse an induction motor like a reversible motor is that the prescribed power cannot be obtained in reverse. This is because the electrical balance of the coils degrades and the output torque decreases. To reverse an induction motor (five lead wire type), connect it as shown below, bring the motor to a complete stop and then reverse it.

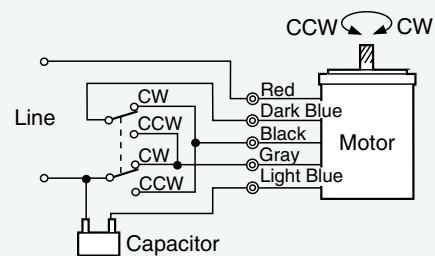

Q9. Can instant reversal of a reversible motor be implemented using a SSR (solid state relay)?

A9. When instant forward/reverse operation is controlled with an SSR, the SSR characteristics can cause shorts in the circuit. Time must be allowed between switching from the SSR for clockwise rotation to the SSR for counterclockwise rotation.

Q10. The connection diagrams shows that a capacitor must be connected. Why is this necessary?

A10. Most all of Oriental Motors standard compact AC motors that fall within the broad group of single-phase induction motors are "capacitor-run motors". To run an induction motor, a rotational magnetic field must be created. Capacitors perform the role of creating a power supply with the phase shift that is required for creating such a rotational magnetic field. Three-phase motors, by contrast, always supply power with different phases, so they do not require capacitors.

Q11. Can I use a capacitor other than the one that comes with the motor?

A11. The capacitor that comes with the motor has a capacitance that was selected to work optimally with the motor. When another capacitor is used, it should be a motor capacitor with the same capacitance and rated voltage as the capacitor that comes with the motor. Electrolytic capacitors may not be used.

Q12. Why do some gearheads output in the same direction as the motor while others output in the opposite direction?

A12. Gearheads reduce the motor speed by 3:1 to 180:1. They do not, however, reduce the speed with a single gear, but with several. The number of speed reductions depends on the gear ratio, so the direction of output shaft rotation differs.

- Rotating in motor axis direction
- Rotating opposite of motor axis direction

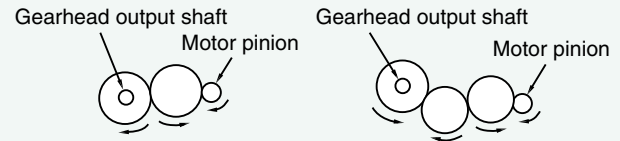

Q13. Can gearheads be used to reduce the motor speed to 1/18,000?

A13. Yes. A gearhead with a gear ratio of 180:1 must be connected to two decimal gearheads with a gear ratio of 10:1. The permissible torque is the same as if the 180:1 gearhead were used alone. The mounting screws must also be longer.

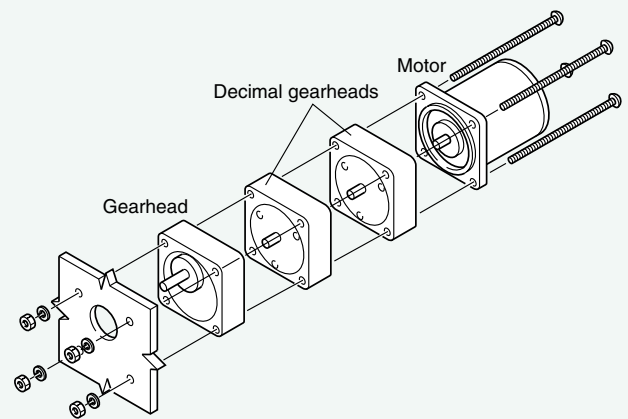

Q14. Do gearheads require oiling?

A14. Oriental Motor lubricates the surface of gears in gearheads with grease. Oiling is not required.

Q15. We wired the induction motor according to the wiring diagram, but it does not move. When we turned the shaft by hand, it started to move in the direction we turned it. What could be the cause of this?

A15. In order to turn a single-phase induction motor, it is necessary to use a capacitor to create two power supplies with different phases to obtain the rotating magnetic field. Therefore, if the capacitor is not properly connected, the phenomenon described occurs. Check for a cut line or contact defect in the capacitor section. The way to check is to measure the voltage across the capacitor terminals and check whether or not it is at least 1.5 times the power supply voltage. If not, the capacitor may not be working properly.

1. Ratings

■ Ratings

Motor rating limitations pertaining to temperature rise are divided into two categories: continuous and short-term ratings. These establish working limitations on output, as well as on voltage, frequency and speed (r/min), and are known as rated output, rated voltage, rated frequency and rated speed (r/min).

■ Continuous and Short-term Ratings

The period during which output can continue without abnormality is called a rating period. When continuous operation at rated output is possible, it is known as the continuous rating. When operation at rated output is only possible for a limited period, it is known as the short-term rating.

2. Output Power

■ Output Power

The amount of work that can be performed in a given period of time is determined by the motor's speed and torque. This rated output value is marked on each motor.

$$\text{Output Power [HP]} = (10^{-6}) \times T \times N$$

1 HP = 746 Watts

where:

- 10⁻⁶: Constant
- T (oz-in): Torque
- N (r/min): Speed

■ Rated Output Power

When optimum characteristics are achieved at rated voltage and frequency in continuous operation, the motor is said to be operating at the rated output. The speed and torque which produce the rated output are called the rated speed and the rated torque. Generally, the term "output" refers to the rated output.

3. Torque

■ Starting Torque ①

This term refers to the torque generated the instant the motor starts. If the motor is subjected to a load greater than this torque, it will not operate.

■ Stalling Torque ②

This is the maximum torque under which the motor will operate at a given voltage and frequency. If a load greater than this torque is applied to the motor, it will stall.

■ Rated Torque ③

This is the torque created when the motor is continuously producing rated output at rated voltage and frequency. It is the torque at rated speed.

■ Static Frictional Torque

Static frictional torque is the torque output required to hold a load when the motor is stopped by an electromagnetic brake or similar device.

■ Permissible Torque

The permissible torque is the maximum torque that can be used when the motor is running. It is limited by the motor's rated torque, temperature rise and the strength of the gearhead used with the motor.

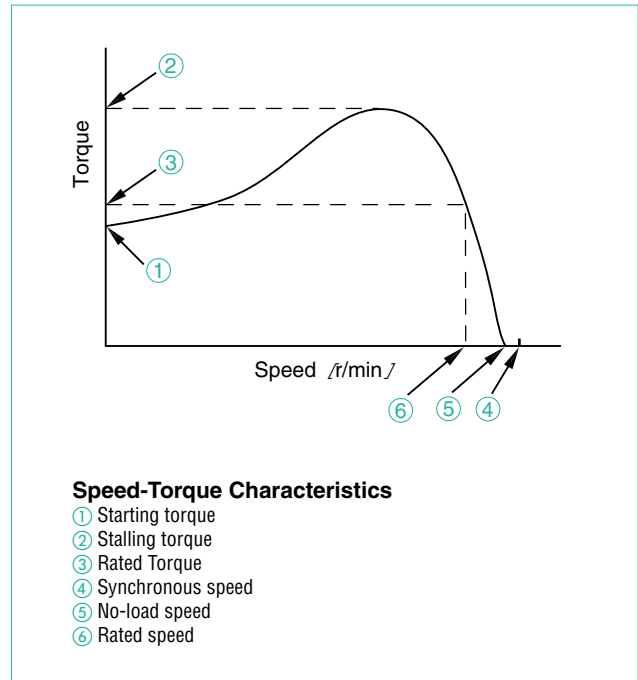

4. Speed

■ Synchronous Speed ④

This is an intrinsic factor determined by the number of poles and the line frequency. It is calculated according to the following formula, and is normally indicated in r/min.

$$N_s = \frac{120f}{P} \text{ [r/min]}$$

where:

- N_s: Synchronous speed [r/min]
- f: Frequency [Hz]
- P: Number of poles
- 120: Constant

For example, for a 4-pole motor with the line frequency of 60Hz, this would be:

$$N_s = \frac{120 \times 60}{4} = 1800 \text{ r/min}$$

■ No-load Speed ⑤

The speed of induction or reversible motors under no-load conditions is 20 ~ 60 r/min lower than synchronous speed because of rotor slip.

■ Rated Speed ⑥

This is the appropriate speed of the motor at rated output. From the standpoint of utility, it is the most desirable speed.

■ Slip

The following formula is one method of expressing speed:

$$S = \frac{N_s - N}{N_s} \text{ or } N = N_s (1 - S)$$

where:

(S: slip)

N_s : Synchronous speed [r/min]

N : Speed under a given load [r/min]

In the case of a 4-pole, 60Hz induction motor operated with a slip of $S=0.1$, this becomes:

$$N = \frac{120 \times 60}{4} (1 - 0.1) = 1800 (1 - 0.1) = 1620 \text{ r/min}$$

5. Overrun

■ Overrun

This is the number of revolutions the motor makes between the time power is cut off and the time that it stops. It is normally indicated either by an angle or by revolutions.

6. Gearhead

■ Gear Ratio

The gear ratio is the ratio by which the gearhead reduces the motor speed [r/min]. The speed at the gearhead's output shaft is the reciprocal of the gear ratio \times motor speed.

■ Maximum Permissible Torque

This is the maximum load torque that can be applied to the gearhead. It is dependent upon such mechanical strength factors as the size and construction of the gears and bearings, and thus varies according to the type and gear ratio of the gearhead.

■ Service Factor

This is a coefficient used to estimate the life of a gearhead. These values are determined from experience in service life tests under various loads and usage conditions.

■ Gearhead Efficiency

This is the efficiency of transmission when the torque is increased with the gearhead engaged. It is expressed as a percentage (%) and is determined by the friction in the gears and bearings used in the gearhead and the resistance of the lubrication oil. The transmission efficiency is usually 90% for each stage of reduction gears, and is 81% for gearheads with only two stage gearheads. As the reduction ratio becomes larger, the number of stages of gears increases, with a consequent reduction in the gear efficiency to 73%, 66% and 59% for each stage of gears added.

■ Overhung Load

This is the load on the gearhead output shaft in the radial direction. The maximum overhung load on a gearhead is called the permissible overhung load and varies with the gearhead type and the distance from the shaft end. This is equivalent to tension under belt drive.

■ Thrust Load

This is the load that is placed in the direction of the gearhead output axis shaft. The maximum thrust load on the gearhead is called the permissible thrust load and differs by the type of gearhead.

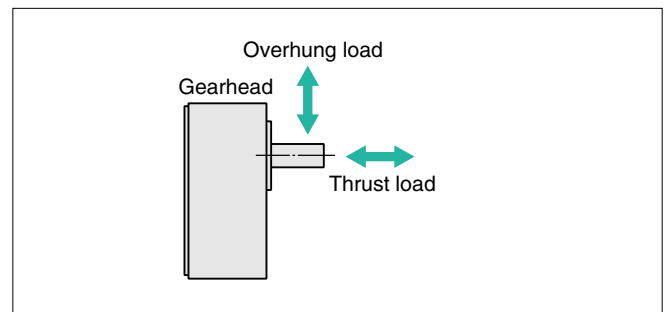

7. Others

■ CW, CCW

This shows the motor rotation direction.

CW is clockwise as seen from the output shaft side and CCW is counterclockwise.

ORIENTAL MOTOR GENERAL CATALOG

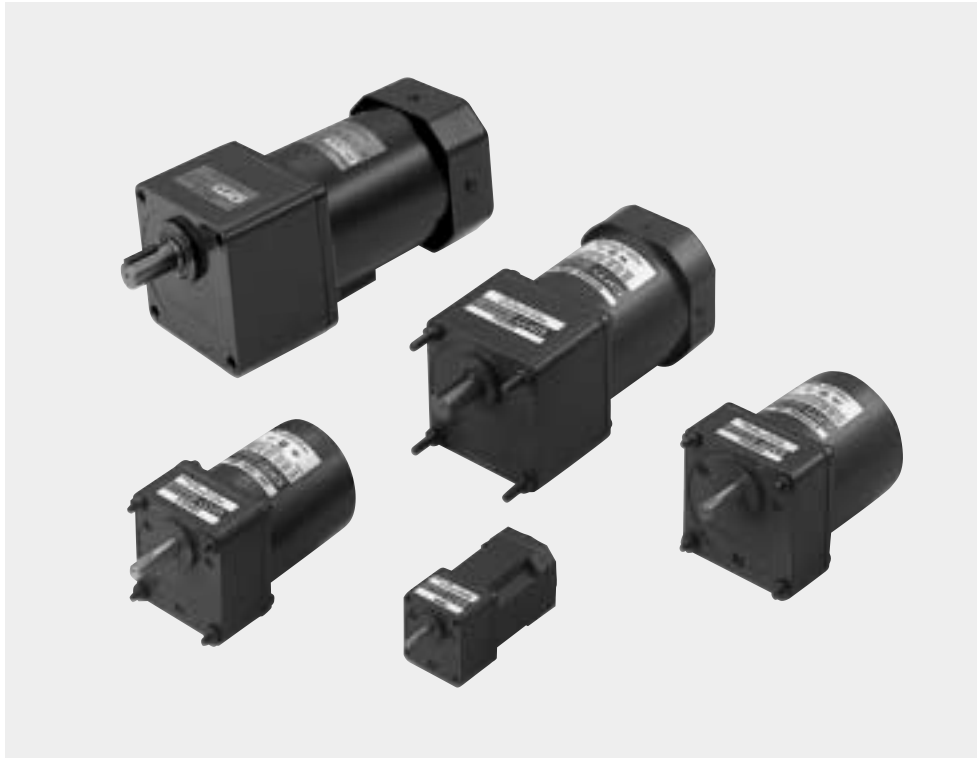

Induction Motors *Reversible Motors* *Synchronous Motors* *Torque Motors*

Product Number Codes.....A-32

Induction Motors

FeaturesA-34

Product Specifications.....A-35

Induction Motors 1W-200WA-38

Reversible Motors

FeaturesA-74

Product Specifications.....A-75

Reversible Motors 1W-90W.....A-78

Synchronous Motors.....A-102

Torque Motors.....A-106

Product Number Code

■ Motor

5 I K 40 GN - AW T U

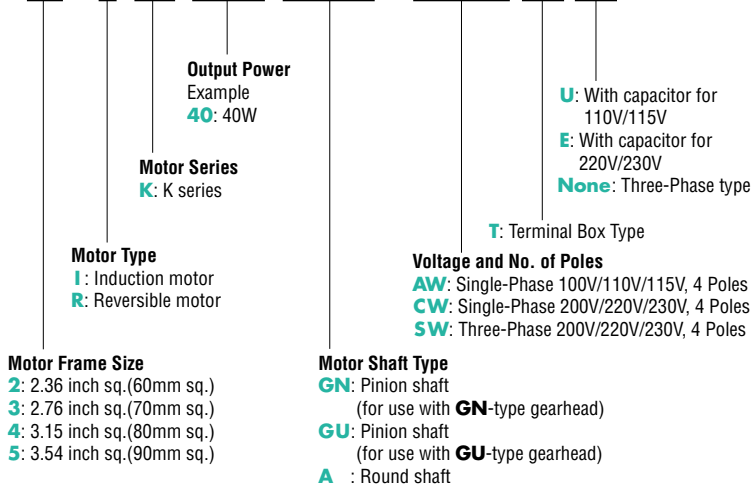

Note : The "U" and "E" at the end of the model name (ordering name)indicate that the unit includes a capacitor. These two letters are not inscribed on the motor nameplate.

■ Gearhead

5 GN 50 KA

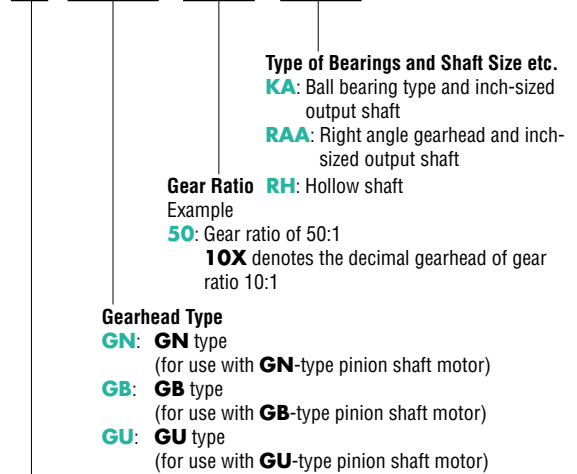

5 I K 60 GU - A F UL

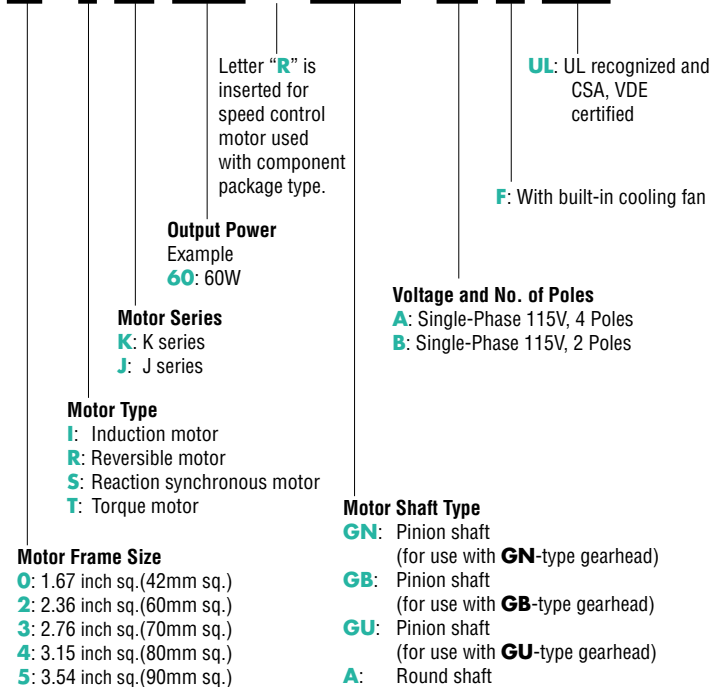

■ Motor

5 I K 40 GN - F C H

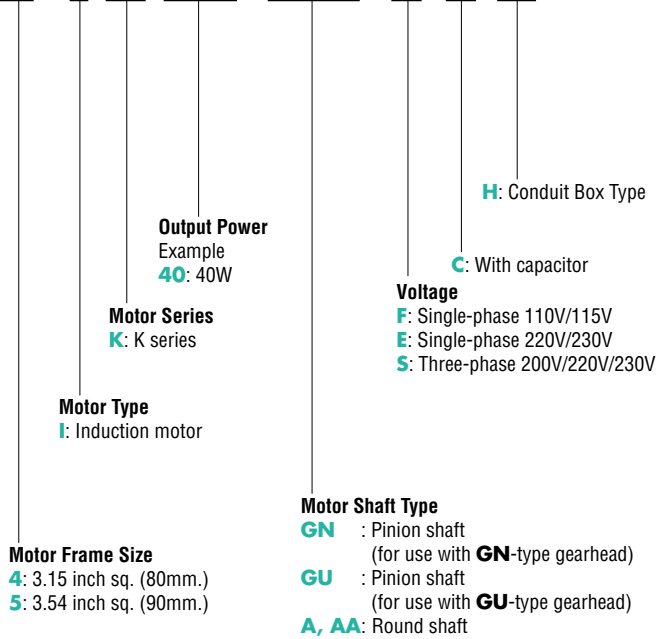

BH I 6 2 F T - 5

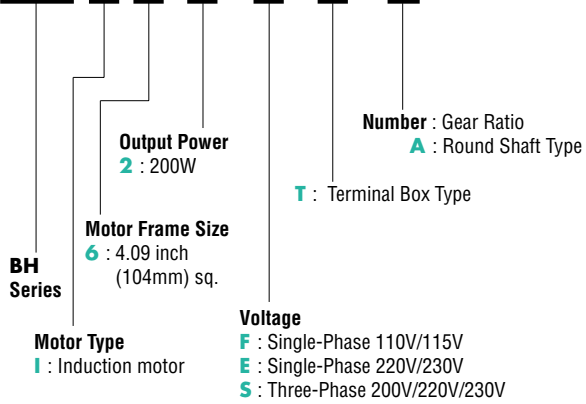

Features of Induction Motors

The speed of induction motors varies with the load. They are used in applications where speed control is not required. Both capacitor-run single-phase motors and three-phase motors are available.



● Capacitor-Run Single-Phase Motors

Most compact single-phase induction motors are capacitor-run. They use a constant secondary coil winding and a capacitor for both starting and normal operation. Starting torque is generally smaller than operating torque, but the structure is simple and reliable, so efficiency is high. Note that a capacitor must be used when operating a single-phase induction motor.

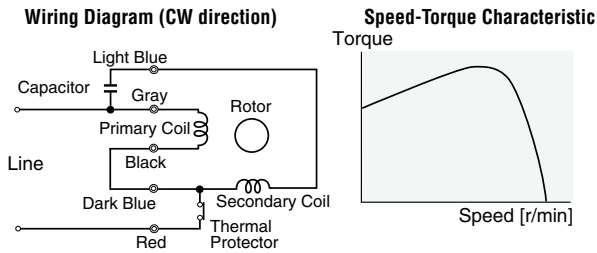

● 2-Pole High-Speed Motors

In principle, this is a single-phase, capacitor-run induction motor except that the speed is twice that of the base model. As opposed to the basic four-pole model with its synchronous speed of 1800r/min at 60Hz, the two-pole version synchronous speed is 3600r/min at 60Hz. This model only comes with a round shaft.

- When using a capacitor with the motor, make sure that the rated capacitance and voltage as indicated on the capacitor correspond to the specifications on the motor.
- Change the direction of motor rotation only after bringing the motor to a stop. If an attempt is made to change the direction of rotation while the motor is rotating, the motor may ignore the reversing command or change its direction of rotation after some delay.

● Three-Phase Motors

These are induction motors driven by three-phase electric power. They are very efficient, have a comparatively large starting torque and are very reliable. They are most commonly used for general drive applications.

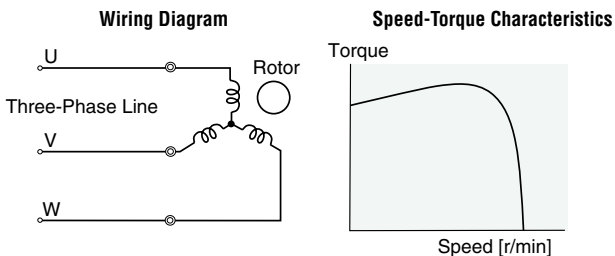

● Speed-Torque Characteristics

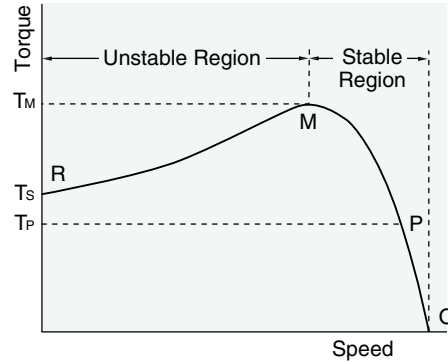

The figure above shows the relationship between the motor speed and torque characteristics when the power supply voltage is maintained at a constant level. Under conditions of no load, the motor rotates at a speed close to synchronous rotation, but as load increases the motor speed drops to a speed (P), where a balance is achieved between load and motor torque (T_p). If load is further increased and reaches point M, the motor can generate no greater torque, and stops at point R. In other words, the motor can be operated in a stable range of between M and O, while the range between R and M represents an unstable area.

● Voltage Characteristics and Capacitor Characteristics

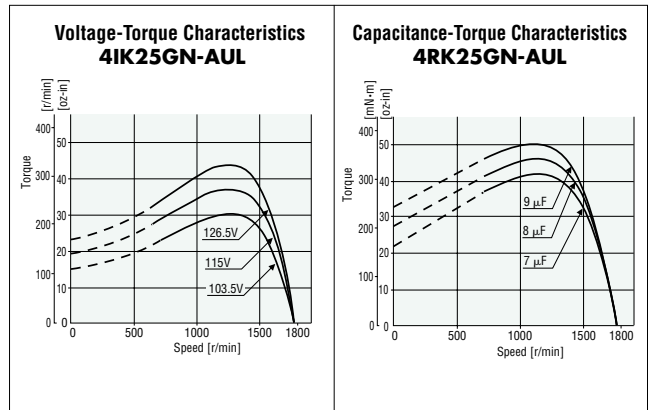

The voltage characteristics curve shows the changes in torque characteristics as the voltage applied to the motor is varied. Torque of induction motors is generally in proportion to the square of the voltage. Torque characteristics also vary greatly according to the value of the capacitor. If the capacitor value is increased, both starting and stopping torque increases, but once it reaches 2.5 ~ 3 times the rated value, operating torque begins to decrease and start-up torque levels off.

If an induction motor does not have sufficient torque, a simple method of boosting torque is to increase input voltage or capacitor value. Such methods, however, cause an increase in power loss and a rise in motor temperature. Therefore, it would be advisable to avoid these methods. However in cases where there is no other way to increase torque, it is recommended to take adequate precautions to dissipate motor heat and always keep the temperature of motor case at 194°F (90°C) or less.

Product Specifications

Induction Motors-4Pole

| Output Power | | Model | | | Voltage | Frequency | Starting Torque | | Rated Torque | | Rated Speed | Page | |
|--------------|-----|---------------------|---------------------|--------------------|------------------|------------------|-----------------|------|--------------|------|-------------|------|------|
| HP | W | Lead Wire Type | Terminal Box Type | Conduit Box Type | V | Hz | oz-in | mN-m | oz-in | mN-m | r/min | | |
| 1/746 | 1 | 0IK1GN-AUL | — | — | Single-Phase 115 | 60 | 1.1 | 8 | 1.1 | 8 | 1200 | A-38 | |
| 1/249 | 3 | 2IJ3GB-AUL | — | — | Single-Phase 115 | 60 | 3.5 | 25 | 2.9 | 21 | 1450 | A-40 | |
| 1/124 | 6 | 2IK6GN-AWU | 2IK6GN-AWTU | — | Single-Phase 110 | 60 | 5.6 | 40 | 5.7 | 41 | 1450 | A-42 | |
| | | | | | Single-Phase 115 | 60 | | | | | | | |
| | | | | | Single-Phase 220 | 60 | 5.6 | 40 | 5.7 | 41 | 1450 | | |
| | | 2IK6GN-CWE | 2IK6GN-CWTE | — | Single-Phase 230 | 50 | 6.2 | 45 | 6.8 | 49 | 1200 | | |
| | | | | | Single-Phase 230 | 60 | 5.6 | 40 | 5.7 | 41 | 1450 | | |
| | | | | | Three-Phase 200 | 50 | 6.8 | 49 | 6.8 | 49 | 1200 | | |
| | | 2IK6GN-SW | 2IK6GN-SWT | — | Three-Phase 200 | 60 | | | | 1450 | | | |
| | | | | | Three-Phase 220 | 60 | 5.7 | 41 | 5.7 | 41 | 1500 | | |
| | | | | | Three-Phase 230 | 60 | | | | 1500 | | | |
| | | 2IK6GN-AUL | — | — | Single-Phase 115 | 60 | 5.6 | 40 | 5.6 | 40 | 1500 | | |
| 1/50 | 15 | 3IK15GN-AWU | — | — | Single-Phase 110 | 60 | 9 | 65 | 14.6 | 105 | 1450 | A-45 | |
| | | | | | Single-Phase 115 | 60 | | | | | | | |
| | | 3IK15GN-CWE | — | — | Single-Phase 220 | 60 | 9 | 65 | 14.6 | 105 | 1450 | | |
| | | | | | Single-Phase 230 | 50 | 10 | 75 | 17.4 | 125 | 1200 | | |
| | | | | | Single-Phase 230 | 60 | 9 | 65 | 14.6 | 105 | 1450 | | |
| | | 3IK15GN-AUL | — | — | Single-Phase 115 | 60 | 10.4 | 75 | 13.9 | 100 | 1500 | | |
| | | 4IJ15GB-AUL | — | — | Single-Phase 115 | 60 | 10.4 | 75 | 13.2 | 95 | 1550 | | |
| 1/30 | 25 | 4IK25GN-AWU | 4IK25GN-AWTU | 4IK25GN-FCH | Single-Phase 110 | 60 | 16.7 | 120 | 23.6 | 170 | 1450 | A-48 | |
| | | | | | Single-Phase 115 | 60 | | | | | | | |
| | | 4IK25GN-CWE | 4IK25GN-CWTE | 4IK25GN-ECH | Single-Phase 220 | 60 | | | 23.6 | 170 | 1450 | | |
| | | | | | Single-Phase 230 | 50 | 16.7 | 120 | 28.5 | 205 | 1200 | | |
| | | | | | Single-Phase 230 | 60 | | | 23.6 | 170 | 1450 | | |
| | | | | | Three-Phase 200 | 50 | 33.3 | 240 | 26.4 | 190 | 1300 | | |
| | | | | | Three-Phase 200 | 60 | | | | | 1550 | | |
| | | 4IK25GN-SW | 4IK25GN-SWT | 4IK25GN-SH | Three-Phase 220 | 60 | 22.2 | 160 | 22.2 | 160 | 1600 | | |
| | | | | | Three-Phase 230 | 60 | | | | 1600 | | | |
| | | 4IK25GN-AUL | — | — | Single-Phase 115 | 60 | 15.3 | 110 | 22.9 | 165 | 1500 | | |
| 1/18.5 | 40 | 5IK40GN-AWU | 5IK40GN-AWTU | 5IK40GN-FCH | Single-Phase 110 | 60 | 27.8 | 200 | 36.1 | 260 | 1500 | A-53 | |
| | | | | | Single-Phase 115 | 60 | | | | | | | |
| | | 5IK40GN-CWE | 5IK40GN-CWTE | 5IK40GN-ECH | Single-Phase 220 | 60 | | | 36.1 | 260 | 1500 | | |
| | | | | | Single-Phase 230 | 50 | 27.8 | 200 | 41.7 | 300 | 1300 | | |
| | | | | | Single-Phase 230 | 60 | | | 36.1 | 260 | 1500 | | |
| | | | | | Three-Phase 200 | 50 | 55.5 | 400 | 41.7 | 300 | 1300 | | |
| | | | | | Three-Phase 200 | 60 | | | | 1550 | | | |
| | | 5IK40GN-SW | 5IK40GN-SWT | 5IK40GN-SH | Three-Phase 220 | 60 | 36.1 | 260 | 36.1 | 260 | 1600 | | |
| | | | | | Three-Phase 230 | 60 | | | | 1600 | | | |
| | | 5IK40GN-AUL | — | — | Single-Phase 115 | 60 | 27.8 | 200 | 36.1 | 260 | 1550 | | |
| 1/12.5 | 60 | 5IK60GU-AWU | 5IK60GU-AWTU | 5IK60GU-FCH | Single-Phase 110 | 60 | 44.4 | 320 | 56.2 | 405 | 1450 | A-58 | |
| | | | | | Single-Phase 115 | 60 | | | | | | | |
| | | 5IK60GU-CWE | 5IK60GU-CWTE | 5IK60GU-ECH | Single-Phase 220 | 60 | | | 56.2 | 405 | 1450 | | |
| | | | | | Single-Phase 230 | 50 | 44.4 | 320 | 68 | 490 | 1200 | | |
| | | | | | Single-Phase 230 | 60 | | | 56.2 | 405 | 1450 | | |
| | | | | | Three-Phase 200 | 50 | 83.3 | 600 | 62.5 | 450 | 1300 | | |
| | | | | | Three-Phase 200 | 60 | | | | 1550 | | | |
| | | 5IK60GU-SW | 5IK60GU-SWT | 5IK60GU-SH | Three-Phase 220 | 60 | 69.4 | 500 | 52.8 | 380 | 1600 | | |
| | | | | | Three-Phase 230 | 60 | | | | 1600 | | | |
| | | 5IK60GU-AFUL | — | — | Single-Phase 115 | 60 | 41.7 | 300 | 52.8 | 380 | 1550 | | |
| 1/8 | 90 | 5IK90GU-AWU | 5IK90GU-AWTU | 5IK90GU-FCH | Single-Phase 110 | 60 | 62.5 | 450 | 81.2 | 585 | 1500 | A-63 | |
| | | | | | Single-Phase 115 | 60 | | | | | | | |
| | | 5IK90GU-CWE | 5IK90GU-CWTE | 5IK90GU-ECH | Single-Phase 220 | 60 | | | 84 | 605 | 1450 | | |
| | | | | | Single-Phase 230 | 50 | 62.5 | 450 | 101.4 | 730 | 1200 | | |
| | | | | | Single-Phase 230 | 60 | | | 84 | 605 | 1450 | | |
| | | | | | Three-Phase 200 | 50 | 118 | 850 | 94.4 | 680 | 1300 | | |
| | | | | | Three-Phase 200 | 60 | | | | 1550 | | | |
| | | | | | Three-Phase 220 | 60 | 97.2 | 700 | 79.2 | 570 | 1600 | | |
| | | | | | Three-Phase 230 | 60 | | | | 1600 | | | |
| | | 5IK90GU-AFUL | — | — | Single-Phase 115 | 60 | 62.5 | 450 | 79.2 | 570 | 1550 | | |
| 1/3.73 | 200 | BHI62F-□ | BHI62FT-□ | — | Single-Phase 110 | 60 | 125 | 900 | 181 | 1300 | 1500 | A-68 | |
| | | | | | Single-Phase 115 | 60 | 139 | 1000 | | | | | |
| | | | | | Single-Phase 220 | 60 | | | 181 | 1300 | 1500 | | |
| | | | | BHI62ET-□ | — | Single-Phase 230 | 50 | 139 | 1000 | 215 | 1550 | | 1250 |
| | | | | | | Single-Phase 230 | 60 | | | 181 | 1300 | | 1500 |
| | | | | | | | Three-Phase 200 | 50 | 215 | 1550 | 215 | | 1550 |
| | | | | | Three-Phase 200 | 60 | 181 | 1300 | 181 | 1300 | 1500 | | |
| | | | | | Three-Phase 220 | 60 | 174 | 1250 | 174 | 1250 | 1550 | | |
| | | | | | Three-Phase 230 | 60 | 167 | 1200 | 167 | 1200 | 1600 | | |

•The "U" and "E" at the end of the model name indicate that the unit includes a capacitor. These two letters are not listed on the motor nameplate.

Induction Motors - 2 Pole (Round shaft type only)

| Output Power | | Model | | | Voltage | Frequency | Starting Torque | | Rated Torque | | Rated Speed | Page |
|--------------|----|--------------------|--|--|------------------|-----------|-----------------|------|--------------|------|-------------|------|
| HP | W | | | | V | Hz | oz-in | mN-m | oz-in | mN-m | r/min | |
| 1/18.5 | 40 | 4IK40A-BA | | | Single-Phase 115 | 60 | 13.2 | 95 | 18 | 130 | 3000 | A-72 |
| 1/12.5 | 60 | 5IK60A-BA | | | Single-Phase 115 | 60 | 16.7 | 120 | 25.7 | 185 | 3200 | |
| 1/8 | 90 | 5IK90A-BFUL | | | Single-Phase 115 | 60 | 30.6 | 220 | 38.9 | 280 | 3200 | |

■ General Specifications

For **-AW**, **-CW** and **-SW** Type

| Item | Specifications |
|---------------------------|---|
| Insulation Resistance | 100M ohms or more when 500V DC is applied between the windings and the frame. |
| Dielectric Strength | Sufficient to withstand 1.5kV at 50Hz and 60Hz applied between the windings and the frame. |
| Temperature Rise | 144°F (80°C) or less measured by the resistance change method after rated motor operation with connecting a gearhead or equivalent heat radiation plate. |
| Insulation Class | Class B (266°F [130°C]) |
| Overheat Protection | 2IK have impedance protection. All others have built-in thermal protector (Automatic return type) Operating temperature, open : 266°F±9°F (130°C±5°C) close: 179.6°F±27°F (82°C±15°C) |
| Ambient Temperature Range | 14°F~104°F (-10°C~+40°C) [Three-phase 200V : 14°F~122°F (-10°C~+50°C)] |
| Ambient Humidity | 85% maximum (noncondensing) |

Equivalent heat radiation plate (material : Aluminum)

| Type (output) | Size inch (mm) | Thickness inch (mm) |
|-------------------------|---------------------|---------------------|
| 2IK Type (6W) | 4.53x4.53 (115x115) | 0.20 (5) |
| 3IK Type (15W) | 4.92x4.92 (125x125) | |
| 4IK Type (25W) | 5.31x5.31 (135x135) | |
| 5IK40 Type (40W) | 6.50x6.50 (165x165) | |
| 5IK60 Type (60W) | 7.87x7.87 (200x200) | |
| 5IK90 Type (90W) | 7.87x7.87 (200x200) | |

For **BHI** Type

| Item | Specifications |
|---------------------------|--|
| Insulation Resistance | 100M ohms or more when 500V DC is applied between the windings and the frame. |
| Dielectric Strength | Sufficient to withstand 1.5kV at 50Hz and 60Hz applied between the windings and the frame. |
| Temperature Rise | 144°F (80°C) or less measured by the resistance change method after rated motor operation with connecting a gearhead or equivalent heat radiation plate. [Three-Phase type : 126°F (70°C)] |
| Insulation Class | Class B (202°F [130°C]) |
| Overheat Protection | Built-in thermal protector (Automatic return type) Operating temperature, open : 302°F±9°F (150°C±5°C) close : 204.8°F±27°F (96°C±15°C) |
| Ambient Temperature Range | 14°F~104°F (-10°C~+40°C) [Three-Phase 200V : 14°F~122°F (-10°C~+50°C)] |
| Ambient Humidity | 85% maximum (noncondensing) |

Equivalent heat radiation plate (material: Aluminum)

| Type (output) | Size inch (mm) | Thickness inch (mm) |
|------------------------|---------------------|---------------------|
| BHI Type (200W) | 9.06x9.06 (230x230) | 0.20 (5) |

For **-AUL**, **-AULA**, **-AFUL**, **-BA** and **-BFUL** Type

| Item | Specifications |
|---------------------------|--|
| Insulation Resistance | 100M ohms or more when 500V DC is applied between the windings and the frame after rated motor operation under normal ambient temperature and humidity. |
| Dielectric Strength | Sufficient to withstand 1.5kV at 50Hz and 60Hz applied between the windings and the frame after rated motor operation under normal ambient temperature and humidity. |
| Temperature Rise | 135°F (75°C) or less measured by the resistance change method after the temperature of the coil has stabilized under normal operation at the rated voltage and frequency. |
| Insulation Class | Class A (221°F [105°C]) |
| Overheat Protection | OIK and 2IK have impedance protection. All others have built-in thermal protector (Automatic return type) Operating temperature, open : 248°F±9°F (120°C±5°C) close: 170.6°F±27°F (77°C±15°C) |
| Ambient Temperature Range | 14°F~104°F (-10°C~+40°C) |
| Ambient Humidity | 85% maximum (noncondensing) |

■ Safety standard and CE Marking

For **-AW(T)U**, **-CW(T)E** and **-SW(T)** Type

| Standards | Certification Body | Standards File No. | CE Marking |
|---|---|--|------------------------|
| UL1004 UL519 (6W Type) UL547 (15W~90W) CAN/CSA C22.2 No.100 CAN/CSA C22.2 No.77 | UL | E64199 (6W) E64197 (15W~90W) | Low Voltage Directives |
| EN60950 * | VDE | 114919ÜG (Single-Phase 6W Lead wire type) 6751ÜG (15W~90W) | |
| | DEMKO | 124234/DK99-00431 (Three-Phase 90w type) | |
| EN60034-1 EN60034-5 IEC60034-11 | Conform to EN/IEC Standards (EN/IEC certifications are scheduled.) | | |

* Excluding conduit box types.

For installation for EN/IEC standards, see page D-2.

For **BHI** Type

| Standards | Certification Body | CE Marking |
|---|---|------------------------|
| UL1004 UL2111 CAN/CSA C22.2 No.100 CAN/CSA C22.2 No.77 | Conform to UL/CSA standards (UL/CSA certifications are scheduled) | Low Voltage Directives |
| EN60950 EN60034-1 EN60034-5 IEC60034-11 | | |

For installation for EN/IEC standards, see page D-2.

For **-AUL**, **-AULA**, **-AFUL**, **-BA** and **-BFUL** Type

| Standards | Certification Body | Standards File No. | CE Marking |
|--|--------------------|----------------------------------|------------------------|
| UL1004 UL519 (6W Type) UL547 (15W~90W Type) CAN/CSA C22.2 No.100 CAN/CSA C22.2 No.77 | UL | E64199(1W~6W) E64197(15W~90W) | Low Voltage Directives |
| EN60950 | CSA | LR47296 | |
| | VDE | 5876ÜG(1W~6W) 5877ÜG(15W~90W) | |

NOTE: UL Mark only for **4IK40A-BA**, **5IK60A-BA**

UL Mark, VDE Mark and CE Mark for **5IK90A-BFUL**

For installation for EN/IEC standards, see page D-2.

INDUCTION MOTORS

Single-Phase

1W (1/746 HP)

Frame Size 1.65 in.sq.(42mm sq.)

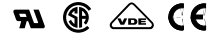

Specifications — Continuous Rating

| Model | | Output Power | | Voltage | Frequency | Current | Starting Torque | | Rated Torque | | Rated Speed | Capacitor |
|-------------------|------------------|--------------|---|---------|-----------|---------|-----------------|------|--------------|------|-------------|-----------|
| Pinion Shaft Type | Round Shaft Type | HP | W | V AC | Hz | A | oz-in | mN·m | oz-in | mN·m | r/min | μF |
| OIK1GN-AUL | OIK1A-AUL | 1/746 | 1 | 115 | 60 | 0.08 | 1.1 | 8 | 1.1 | 8 | 1200 | 1.0 |

●products listed above are impedance protected.

Gearmotor — Torque Table

Unit = Upper values: lb-in / Lower values: N-m

| Model | Speed r/min Gear Ratio | 600 | 500 | 360 | 300 | 240 | 200 | 144 | 120 | 100 | 72 | 60 | 50 | 36 | 30 | 24 | 20 | 18 | 15 | 12 | 10 |
|----------------------------|---------------------------|----------|------------|----------|----------|------------|----------|-------------|-----------|-----------|-----------|-----------|-----------|-----------|-----------|-----------|-----------|------------|------------|------------|------------|
| | | 3 | 3.6 | 5 | 6 | 7.5 | 9 | 12.5 | 15 | 18 | 25 | 30 | 36 | 50 | 60 | 75 | 90 | 100 | 120 | 150 | 180 |
| OIK1GN-AUL / OGN□KA | | 0.17 | 0.20 | 0.28 | 0.33 | 0.42 | 0.50 | 0.63 | 0.75 | 0.90 | 1.1 | 1.4 | 1.6 | 2.3 | 2.7 | 3.0 | 3.7 | 4.1 | 4.9 | 6.1 | 7.3 |
| | | 0.019 | 0.023 | 0.032 | 0.039 | 0.049 | 0.058 | 0.073 | 0.088 | 0.11 | 0.13 | 0.16 | 0.19 | 0.26 | 0.32 | 0.35 | 0.42 | 0.47 | 0.57 | 0.71 | 0.85 |

- Gearheads are sold separately. Decimal gearhead is not available for **OGN** type.
- Enter the gear ratio in the box (□) within the model number. A colored background indicates gear shaft rotation in the same direction as the motor shaft; a white background indicates rotation in the opposite direction.
- The speed is calculated by dividing the motor's synchronous speed (60 Hz : 1800 r/min) by the gear ratio. The actual speed is 2 ~ 20% less than the displayed value, depending on the size of the load.

Wiring Diagrams

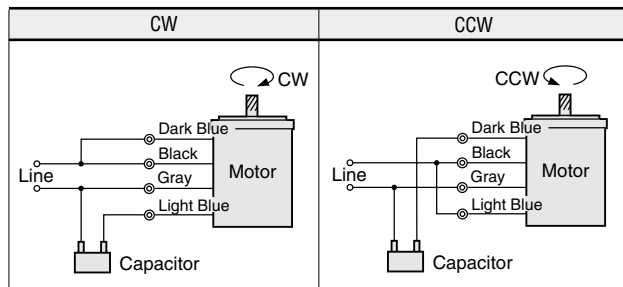

The direction of motor rotation is as viewed from the shaft end of the motor.

Change the direction of motor rotation only after bringing the motor to a stop. If an attempt is made to change the direction of rotation while the motor is rotating, the motor may ignore the reversing command or change its direction of rotation after some delay.

■ Dimensions Scale 1/4, Unit =inch (mm)

Motor

OIK1GN-AUL

Weight (Mass): 0.7 lb. (0.3 kg)

Gearhead

ONG□KA

Weight (Mass): 0.44 lb. (0.2 kg)

OIK1A-AUL Round Shaft Type

Weight (Mass): 0.7 lb.(0.3 kg)

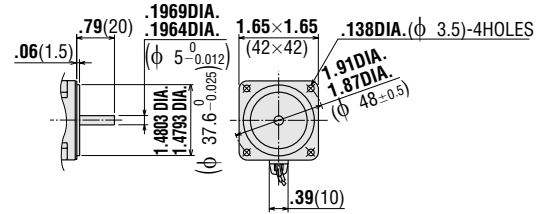
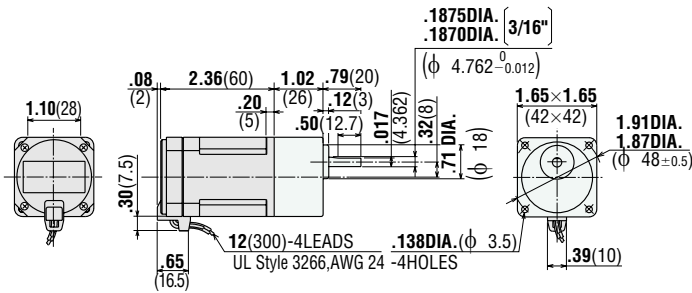

● Capacitor (included with the motor)

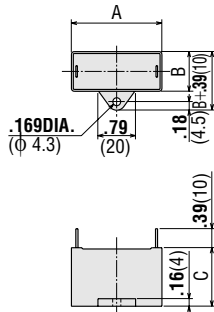

| Motor Model | Capacitor Model | Dimensions inch (mm) | | | Weight oz (g) |
|-------------|-----------------|----------------------|--------|--------|---------------|
| | | A | B | C | |
| OIK1GN-AUL | CH10UL | 1.22 | .57 | .93 | 0.60 (17) |
| OIK1A-AUL | | (31) | (14.5) | (23.5) | |

Capacitor cap is provided with the capacitor.

■ Accessories

● Motor Mounting Brackets

Optional die-cast aluminum mounting brackets are available. They can be used to install motors with or without gearheads. See page [A-266] for the dimensions.

Model name **SOL0U04**



● Flexible Coupling

Optional clamping couplings are available. See page [A-260] for the dimensions.



INDUCTION MOTORS

Single-Phase

3W (1/249 HP)

Frame Size 2.36 in.sq.(60mm sq.)



Specifications — Continuous Rating



| Model | | Output Power | | Voltage | Frequency | Current | Starting Torque | | Rated Torque | | Rated Speed | Capacitor |
|-------------------|-------------------|--------------|---|---------|-----------|---------|-----------------|------|--------------|------|-------------|-----------|
| Pinion Shaft Type | Round Shaft Type | HP | W | V AC | Hz | A | oz-in | mN·m | oz-in | mN·m | r/min | μF |
| 2IJ3GB-AUL | 2IJ3A-AULA | 1/249 | 3 | 115 | 60 | 0.14 | 3.5 | 25 | 2.9 | 21 | 1450 | 1.5 |

•These products are impedance protected.

Gearmotor — Torque Table

The maximum permissible torque with a decimal gearhead with a gear ratio of 10 is 13 lb-in (1.5 N-m)

Unit = Upper values: lb-in / Lower values: N-m

| Model | Speed r/min | 600 | 500 | 360 | 300 | 240 | 200 | 144 | 120 | 100 | 72 | 60 | 50 | 36 | 30 | 24 | 20 | 18 | 15 | 12 | 10 | 7.2 | 6 | 5 |
|----------------------------|-------------|----------|------------|----------|----------|------------|----------|-------------|-----------|-----------|-----------|-----------|-----------|-----------|-----------|-----------|-----------|------------|------------|------------|------------|------------|------------|------------|
| | Gear Ratio | 3 | 3.6 | 5 | 6 | 7.5 | 9 | 12.5 | 15 | 18 | 25 | 30 | 36 | 50 | 60 | 75 | 90 | 100 | 120 | 150 | 180 | 250 | 300 | 360 |
| 2IJ3GB-AUL / 2GB□KA | | 0.44 | 0.53 | 0.73 | 0.88 | 1.1 | 1.3 | 1.8 | 2.2 | 2.6 | 3.3 | 4.0 | 4.8 | 6.0 | 7.2 | 9.0 | 11 | 12 | 13 | 13 | 13 | 13 | 13 | 13 |
| | | 0.051 | 0.061 | 0.085 | 0.11 | 0.13 | 0.15 | 0.21 | 0.26 | 0.31 | 0.38 | 0.46 | 0.55 | 0.69 | 0.83 | 1.0 | 1.2 | 1.4 | 1.5 | 1.5 | 1.5 | 1.5 | 1.5 | 1.5 |

- Gearheads are sold separately.
- Enter the gear ratio in the box (□) within the model number. A colored background indicates gear shaft rotation in the same direction as the motor shaft; a white background indicates rotation in the opposite direction.
- The speed is calculated by dividing the motor's synchronous speed (60 Hz : 1800 r/min) by the gear ratio. The actual speed is 2 ~ 20% less than the displayed value, depending on the size of the load.

Wiring Diagrams

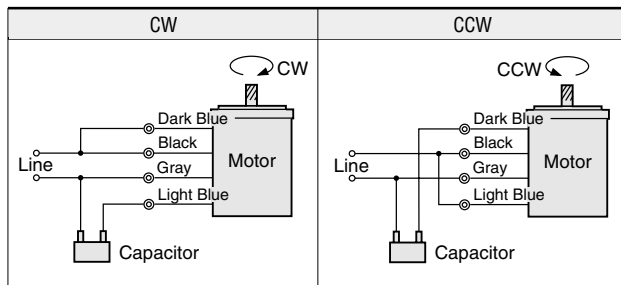

The direction of motor rotation is as viewed from the shaft end of the motor.

Change the direction of motor rotation only after bringing the motor to a stop. If an attempt is made to change the direction of rotation while the motor is rotating, the motor may ignore the reversing command or change its direction of rotation after some delay.

■ Dimensions Scale 1/4, Unit = inch (mm)

● Motor/Gearhead

2IJ3GB-AUL

Weight (Mass): 1.3 lb.(0.6 kg)

2GB□KA

Weight (Mass): 0.66 lb.(0.3 kg)

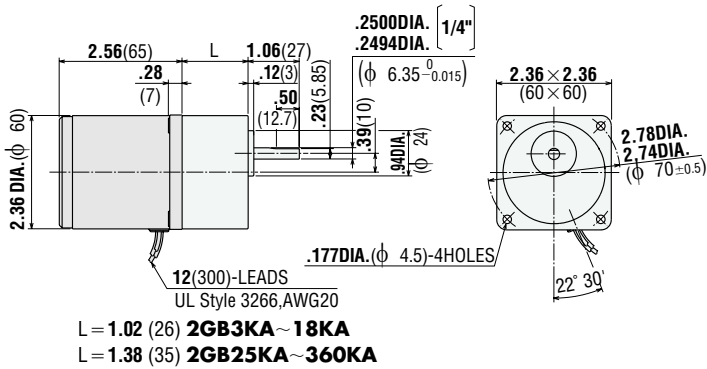

2IJ3A-AULA Round Shaft Type

Weight (Mass): 1.3 lb.(0.6 kg)

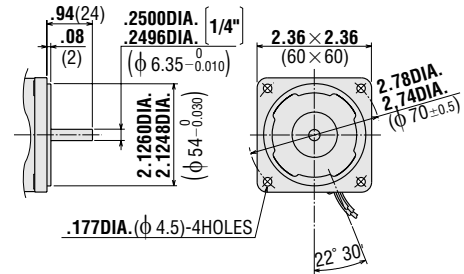

● Decimal Gearhead

2GB10XK Weight (Mass): 0.44 lb.(0.2 kg)

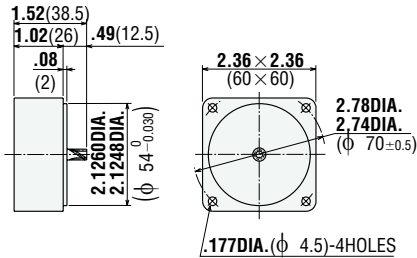

● Capacitor (included with the motor)

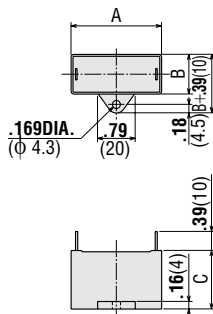

| Motor Model | Capacitor Model | Dimensions inch (mm) | | | Weight oz (g) |
|-------------|-----------------|----------------------|------|------|---------------|
| | | A | B | C | |
| 2IJ3GB-AUL | CH15BUL | 1.46 | .71 | 1.06 | 0.81 (23) |
| 2IJ3A-AULA | | (37) | (18) | (27) | |

Capacitor cap is provided with the capacitor.

■ Accessories

● Motor Mounting Brackets

Optional die-cast aluminum mounting brackets are available. They can be used to install motors with or without gearheads. See page [A-266] for the dimensions.

Model name **SOL2U08**



● Flexible Coupling

Optional clamping couplings are available. See page [A-260] for the dimensions.



INDUCTION MOTORS

Single-Phase, Three-Phase

6W (1/124 HP)

Frame Size 2.36 in.sq.(60mm sq.)



Specifications — Continuous Rating



| Model | | Output Power | Voltage | Frequency | Current | Starting Torque | Rated Torque | Rated Speed | Capacitor | | | |
|--|---|------------------|---------|-----------------|---------|-----------------|--------------|-------------|-----------|------|-------|------|
| Upper Model Name:Pinion Shaft Type | Lower Model Name():Round Shaft Type | | | | | | | | | | | |
| Lead Wire Type | Terminal Box Type | HP | W | V | Hz | A | oz-in | mN·m | oz-in | mN·m | r/min | μF |
| Dimension ① | Dimension ② | | | | | | | | | | | |
| 2IK6GN-AWU (2IK6A-AWU) | 2IK6GN-AWTU (2IK6A-AWTU) | Single-Phase 110 | | 60 | 0.2 | 5.6 | 40 | 5.7 | 41 | 1450 | 2.5 | |
| | | Single-Phase 115 | | 60 | | | | | | | | |
| 2IK6GN-CWE (2IK6A-CWE) | 2IK6GN-CWTE (2IK6A-CWTE) | Single-Phase 220 | | 60 | 0.09 | 5.6 | 40 | 5.7 | 41 | 1450 | 0.6 | |
| | | Single-Phase 230 | | 50 | | | | | | | | |
| | | Single-Phase 230 | | 60 | | | | | | | | |
| | | Single-Phase 230 | | 60 | | | | | | | | |
| 2IK6GN-SW (2IK6A-SW) | 2IK6GN-SWT (2IK6A-SWT) | 1/124 | 6 | Three-Phase 200 | | 50 | 0.09 | 6.8 | 49 | 6.8 | 49 | 1200 |
| | | | | Three-Phase 200 | | 60 | | | | | | |
| | | | | Three-Phase 220 | | 60 | | | | | | |
| | | | | Three-Phase 230 | | 60 | | | | | | |
| 2IK6GN-AUL (2IK6A-AULA) | — | Single-Phase 115 | | 60 | 0.18 | 5.6 | 40 | 5.6 | 40 | 1500 | 2 | |
| | | | | | | | | | | | | |

- These products are impedance protected.
- The "U" and "E" at the end of the model name indicate that the unit includes a capacitor. These two letters are not listed on the motor nameplate. When the motor is approved under various safety standards, the nameplate is adopted.
- The terminal box type of the motors are not VDE approved.

Gearmotor — Torque Table

The maximum permissible torque with a decimal gearhead with a gear ratio of 10 is 26 lb-in (3N·m).

Single-Phase 115V/230V, Three-Phase 230V 60Hz

Unit = Upper values: lb-in / Lower values: N·m

| Model | Speed r/min | Gear Ratio | | | | | | | | | | | | | | | | | | | |
|---|---------------|------------|------|------|------|------|------|------|------|------|------|------|-----|-----|-----|-----|-----|-----|----|----|----|
| | | 600 | 500 | 360 | 300 | 240 | 200 | 144 | 120 | 100 | 72 | 60 | 50 | 36 | 30 | 24 | 20 | 18 | 15 | 12 | 10 |
| 2IK6GN-AWU 2IK6GN-AWTU 2IK6GN-CWE 2IK6GN-CWTE 2IK6GN-SW 2IK6GN-SWT | 2GN□KA | 0.87 | 1.0 | 1.4 | 1.7 | 2.2 | 2.6 | 3.6 | 4.3 | 5.2 | 6.5 | 7.8 | 9.4 | 12 | 14 | 18 | 21 | 24 | 26 | 26 | 26 |
| | | 0.10 | 0.12 | 0.17 | 0.20 | 0.25 | 0.30 | 0.42 | 0.50 | 0.60 | 0.75 | 0.90 | 1.1 | 1.4 | 1.6 | 2.0 | 2.4 | 2.7 | 3 | 3 | 3 |
| 2IK6GN-AUL / 2GN□KA | 2GN□KA | 0.85 | 1.0 | 1.4 | 1.7 | 2.1 | 2.6 | 3.5 | 4.3 | 5.1 | 6.4 | 7.7 | 9.2 | 12 | 14 | 17 | 21 | 23 | 26 | 26 | 26 |
| | | 0.097 | 0.12 | 0.16 | 0.19 | 0.24 | 0.29 | 0.41 | 0.49 | 0.58 | 0.73 | 0.88 | 1.1 | 1.3 | 1.6 | 2.0 | 2.4 | 2.6 | 3 | 3 | 3 |

Single-Phase 230V 50Hz

Unit = Upper values: lb-in / Lower values: N·m

| Model | Speed r/min | Gear Ratio | | | | | | | | | | | | | | | | | | | |
|---|---------------|------------|------|------|------|------|------|------|------|------|------|-----|-----|-----|-----|-----|-----|----|------|----|-----|
| | | 500 | 416 | 300 | 250 | 200 | 166 | 120 | 100 | 83 | 60 | 50 | 41 | 30 | 25 | 20 | 16 | 15 | 12.5 | 10 | 8.3 |
| 2IK6GN-CWE 2IK6GN-CWTE | 2GN□KA | 1.0 | 1.2 | 1.7 | 2.1 | 2.6 | 3.1 | 4.3 | 5.2 | 6.2 | 7.8 | 9.3 | 11 | 14 | 17 | 21 | 25 | 26 | 26 | 26 | 26 |
| | | 0.12 | 0.14 | 0.20 | 0.24 | 0.30 | 0.36 | 0.50 | 0.60 | 0.71 | 0.89 | 1.1 | 1.3 | 1.6 | 1.9 | 2.4 | 2.9 | 3 | 3 | 3 | 3 |

- Gearheads are sold separately.
- Enter the gear ratio in the box (□) within the model number. A colored background indicates gear shaft rotation in the same direction as the motor shaft; a white background indicates rotation in the opposite direction.
- The speed is calculated by dividing the motor's synchronous speed (50 Hz: 1500r/min, 60 Hz: 1800 r/min) by the gear ratio. The actual speed is 2 ~ 20% less than the displayed value, depending on the size of the load.

■ Dimensions Scale 1/4, Unit = inch (mm)

① Motor/Gearhead

2IK6GN-AWU
2IK6GN-CWE
2IK6GN-SW
2IK6GN-AUL

Weight (Mass): 1.5 lb.(0.7 kg)

2GN□KA

Weight (Mass): 0.88 lb.(0.4 kg)

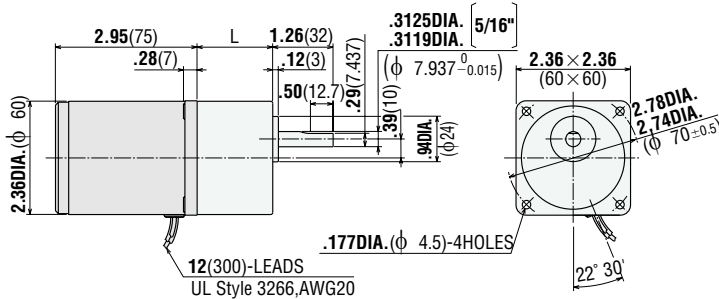

L = 1.18 (30) **2GN3KA~18KA**
 L = 1.57 (40) **2GN25KA~180KA**

2IK6A-AWU
2IK6A-CWE
2IK6A-SW
2IK6A-AULA

Weight (Mass): 1.5 lb.(0.7 kg)

Round Shaft Type

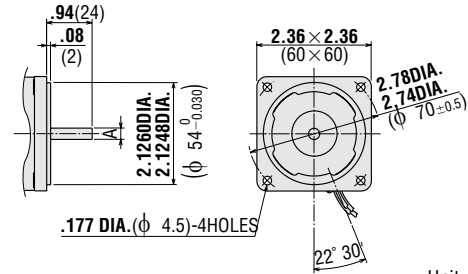

Unit = inch (mm)

| Model | Shaft diameter A |
|-------------------|---|
| 2IK6A-AWU | .2362DIA. (φ 6 ⁰ _{.012}) |
| 2IK6A-CWE | .2357DIA. (φ 6 ⁰ _{.012}) |
| 2IK6A-SW | |
| 2IK6A-AULA | .2500DIA. [1/4"](φ 6.35 ⁰ _{.010}) .2496DIA. |

② Motor/Gearhead

2IK6GN-AWTU
2IK6GN-CWTE
2IK6GN-SWT

Weight (Mass): 1.7 lb.(0.75 kg)

2GN□KA

Weight (Mass): 0.88 lb.(0.4 kg)

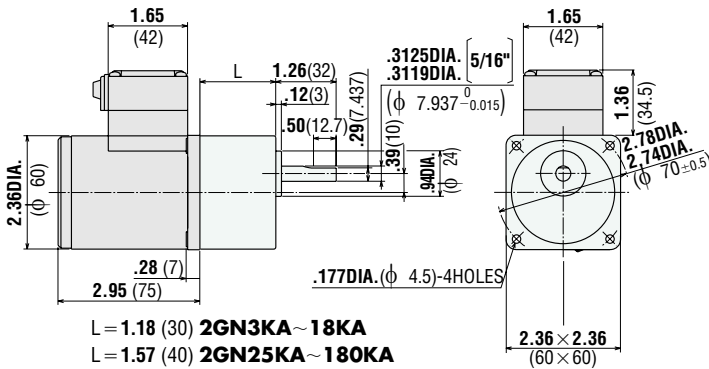

L = 1.18 (30) **2GN3KA~18KA**
 L = 1.57 (40) **2GN25KA~180KA**

Use cabtyre cable with the diameter of .27DIA.(φ 6.8)~.34DIA.(φ 8.6).

2IK6A-AWTU
2IK6A-CWTE
2IK6A-SWT

Weight (Mass): 1.7 lb.(0.75 kg)

Round Shaft Type

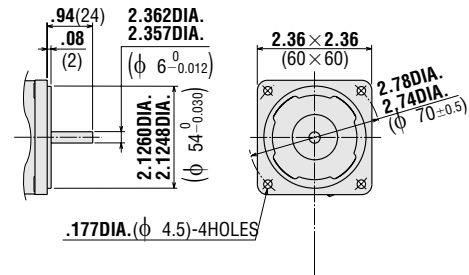

● Decimal Gearhead

2GN10XK Weight (Mass): 0.44 lb.(0.2 kg)

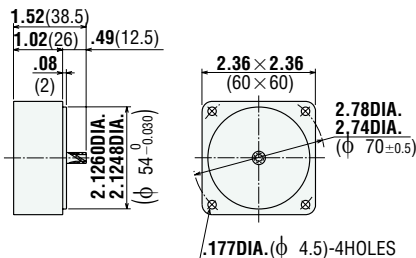

● **Capacitor** (included with the motor)

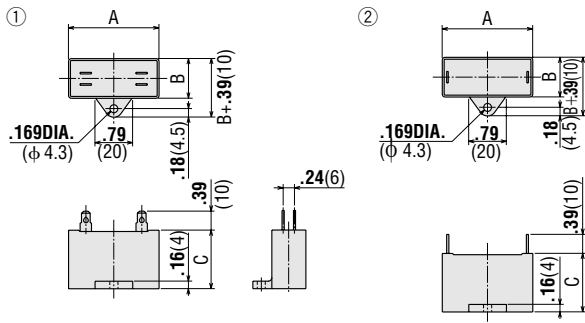

| Motor Model | Capacitor Model | Dimensions in. (mm) | | | Weight (Mass) oz (g) | Dimension No. |
|--------------------|-----------------|---------------------|------------|------------|----------------------|---------------|
| | | A | B | C | | |
| 2IK6GN-AW□U | CH25FAUL | 1.22 (31) | .67 (17) | 1.06 (27) | 0.71 (20) | ① |
| 2IK6A-AW□U | | | | | | |
| 2IK6GN-CW□E | CH06BFAUL | 1.22 (31) | .57 (14.5) | .93 (23.5) | 0.53 (15) | ① |
| 2IK6A-CW□E | | | | | | |
| 2IK6GN-AUL | CH20UL | 1.22 (31) | .57 (14.5) | .93 (23.5) | 0.53 (15) | ② |
| 2IK6A-AULA | | | | | | |

If you need to order a capacitor without a motor, add "-C" to the capacitor model number shown. A capacitor cap is always included with a capacitor.

■ **Wiring Diagrams** The direction of motor rotation is as viewed from the shaft end of the motor.

| Model | Lead Wire Type | | | Terminal Box Type | |
|-----------|--|--|-------------------|--|--|
| | 2IK6GN-AWU 2IK6GN-CWE | 2IK6GN-SW | 2IK6GN-AUL | 2IK6GN-AWTU 2IK6GN-CWTE | 2IK6GN-SWT |
| Direction | | | | | |
| CW | | | | | |
| CCW | To rotate the motor in a clockwise (CW) direction, flip switch SW to CW. To rotate it in a counterclockwise (CCW) direction, flip switch SW to CCW. | To change the rotation, change any two connections between U, V and W. | | To rotate the motor in a clockwise (CW) direction, flip switch SW to CW. To rotate it in a counterclockwise (CCW) direction, flip switch SW to CCW. | To change the rotation, change any two connections between U, V and W. |

Change the direction of motor rotation only after bringing the motor to a stop.

If an attempt is made to change the direction of rotation while the motor is rotating, the motor may ignore the reversing command or change its direction of rotation after some delay.

■ **Accessories**

● **Motor Mounting Brackets**

Optional die-cast aluminum mounting brackets are available. They can be used to install motors with or without gearheads. See page [A-266] for the dimensions.

Model name **SOL2U08**



● **Flexible Coupling**

Optional clamping couplings are available. See page [A-260] for the dimensions.





INDUCTION MOTORS

Single-Phase

15w (1/50 HP)

Frame Size 2.76 in.sq.(□70mm) or 3.15 in.sq.(□80mm)



Specifications — Continuous Rating

| Model | | Output Power | Voltage | Frequency | Current | Starting Torque | Rated Torque | Rated Speed | Capacitor | | | | |
|--|--------------------------------------|------------------|---------|------------------|---------|-----------------|--------------|-------------|-----------|------|-------|-----|--|
| Upper Model Name:Pinion Shaft Type | Lower Model Name():Round Shaft Type | | | | | | | | | | | | |
| Lead Wire Type | Lead Wire Type | HP | W | V | Hz | A | oz-in | mN·m | oz-in | mN·m | r/min | μF | |
| Dimension ① | Dimension ② | | | | | | | | | | | | |
| 3IK15GN-AWU (3IK15A-AWU) | — | 1/50 | 15 | Single-Phase 110 | 60 | 0.33 | 9 | 65 | 14.6 | 105 | 1450 | 4.5 | |
| | | | | Single-Phase 115 | 60 | 0.34 | | | | | | | |
| 3IK15GN-CWE (3IK15A-CWE) | — | | | Single-Phase 220 | 60 | 0.16 | 9 | 65 | 14.6 | 105 | 1450 | | |
| | | | | Single-Phase 230 | 50 | 0.19 | 10 | 75 | 17.4 | 125 | 1200 | 1 | |
| | | | | Single-Phase 230 | 60 | 0.16 | 9 | 65 | 14.6 | 105 | 1450 | | |
| 3IK15GN-AUL (3IK15A-AULA) | — | | | Single-Phase 115 | 60 | 0.33 | 10.4 | 75 | 13.9 | 100 | 1500 | 4 | |
| 4IJ15GB-AUL (4IJ15A-AULA) | — | Single-Phase 115 | 60 | 0.35 | 10.4 | 75 | 13.2 | 95 | 1550 | 3 | | | |

- The product contains a built-in thermal protector. When a motor overheats for any reason, the thermal protector is opened and the motor stops. When the motor temperature drops, the thermal protector closes and the motor restarts. Be sure to turn the motor off before inspecting.
- The "U" and "E" at the end of the model name indicate that the unit includes a capacitor. These two letters are not listed on the motor nameplate. When the motor is approved under various safety standards, the nameplate is adopted.

Gearmotor — Torque Table

The maximum permissible torque with a decimal gearhead with a gear ratio of 10 is 43 lb-in (5N·m).

Single-Phase 115V/230V, 60Hz

Unit = Upper values: lb-in / Lower values: N·m

| Model | Speed r/min | Gear Ratio | | | | | | | | | | | | | | | | | | | | | | | |
|--|-------------|------------|------|------|------|------|------|-----|-----|-----|-----|-----|-----|-----|-----|----|----|----|----|----|----|-----|----|---|--|
| | | 600 | 500 | 360 | 300 | 240 | 200 | 144 | 120 | 100 | 72 | 60 | 50 | 36 | 30 | 24 | 20 | 18 | 15 | 12 | 10 | 7.2 | 6 | 5 | |
| 3IK15GN-AWU / 3IK15GN-CWE / 3GN□KA | 2.2 | 2.7 | 3.7 | 4.4 | 5.5 | 6.7 | 9.2 | 11 | 13 | 17 | 20 | 24 | 30 | 36 | 43 | 43 | 43 | 43 | 43 | 43 | — | — | — | | |
| | 0.26 | 0.31 | 0.43 | 0.51 | 0.64 | 0.77 | 1.1 | 1.3 | 1.5 | 1.9 | 2.3 | 2.8 | 3.5 | 4.2 | 5 | 5 | 5 | 5 | 5 | 5 | — | — | — | | |
| 3IK15GN-AUL / 3GN□KA | 2.1 | 2.5 | 3.5 | 4.2 | 5.3 | 6.3 | 8.8 | 11 | 13 | 16 | 19 | 23 | 29 | 34 | 43 | 43 | 43 | 43 | 43 | 43 | — | — | — | | |
| | 0.24 | 0.29 | 0.41 | 0.49 | 0.61 | 0.73 | 1.0 | 1.2 | 1.5 | 1.8 | 2.2 | 2.6 | 3.3 | 4 | 5 | 5 | 5 | 5 | 5 | 5 | — | — | — | | |
| 4IJ15GB-AUL / 4GB□KA | 2.0 | 2.4 | 3.3 | 4.0 | 5.0 | 6.0 | 8.3 | 9.9 | 12 | 15 | 18 | 22 | 27 | 32 | 41 | 43 | 43 | 43 | 43 | 43 | 43 | 43 | 43 | | |
| | 0.23 | 0.28 | 0.38 | 0.46 | 0.58 | 0.69 | 0.96 | 1.2 | 1.4 | 1.7 | 2.1 | 2.5 | 3.1 | 3.8 | 4.7 | 5 | 5 | 5 | 5 | 5 | 5 | 5 | 5 | | |

Single-Phase 230V 50Hz

Unit = Upper values: lb-in / Lower values: N·m

| Model | Speed r/min | Gear Ratio | | | | | | | | | | | | | | | | | | | | |
|------------------------------------|-------------|------------|------|------|------|------|-----|-----|-----|-----|-----|-----|-----|----|----|----|----|----|------|----|-----|----|
| | | 500 | 416 | 300 | 250 | 200 | 166 | 120 | 100 | 83 | 60 | 50 | 41 | 30 | 25 | 20 | 16 | 15 | 12.5 | 10 | 8.3 | |
| 3IK15GN-CWE / 3GN□KA | 2.6 | 3.2 | 4.4 | 5.3 | 6.6 | 7.9 | 11 | 13 | 16 | 20 | 24 | 29 | 36 | 43 | 43 | 43 | 43 | 43 | 43 | 43 | 43 | 43 |
| | 0.30 | 0.36 | 0.51 | 0.61 | 0.76 | 0.91 | 1.3 | 1.5 | 1.8 | 2.3 | 2.7 | 3.3 | 4.1 | 5 | 5 | 5 | 5 | 5 | 5 | 5 | 5 | 5 |

- Gearheads are sold separately.
- Enter the gear ratio in the box (□) within the model number. A colored background indicates gear shaft rotation in the same direction as the motor shaft; a white background indicates rotation in the opposite direction.
- The speed is calculated by dividing the motor's synchronous speed (50 Hz: 1500r/min, 60 Hz: 1800 r/min) by the gear ratio. The actual speed is 2 ~ 20% less than the displayed value, depending on the size of the load.

■ Dimensions Scale 1/4, Unit = inch (mm)

① Motor/Gearhead

3IK15GN-AWU
3IK15GN-CWE
3IK15GN-AUL

Weight (Mass): 2.4 lb.(1.1 kg)

3GN□KA

Weight (Mass): 1.21 lb.(0.55 kg)

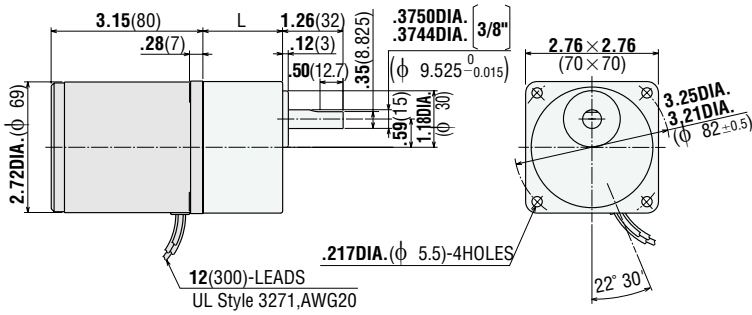

L = 1.26 (32) **3GN3KA ~ 18KA**
 L = 1.65 (42) **3GN25KA ~ 180KA**

● Decimal Gearhead

3GN10XK Weight (Mass): 0.66 lb.(0.3 kg)

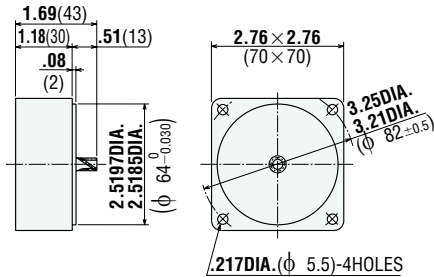

3IK15A-AWU Round Shaft Type
3IK15A-CWE
3IK15A-AULA

Weight (Mass): 2.4 lb.(1.1 kg)

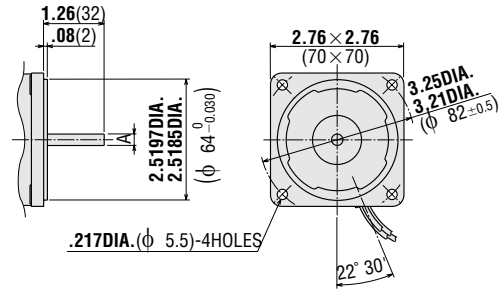

Unit = inch (mm)

| Model | Shaft Diameter A |
|--------------------|---|
| 3IK15A-AWU | .2362DIA. (φ 6.0 _{0.012}) |
| 3IK15A-CWE | .2357DIA. (φ 6.0 _{0.012}) |
| 3IK15A-AULA | .2500DIA. [1/4"] (φ 6.350 _{0.010}) .2496DIA. |

② Motor/Gearhead

4IJ15GB-AUL

Weight (Mass): 3.1 lb.(1.4 kg)

4GB□KA

Weight (Mass): 1.43 lb.(0.65 kg)

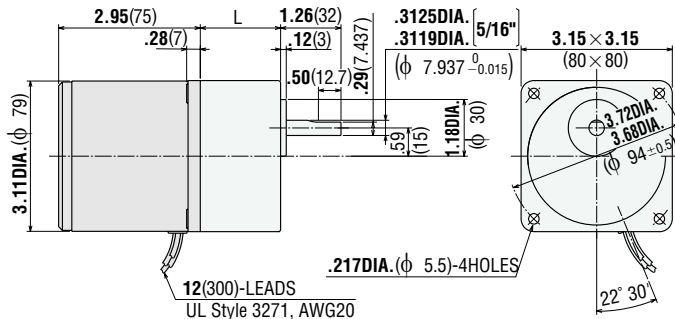

L = 1.26 (32) **4GB3KA ~ 18KA**
 L = 1.67 (42.5) **4GB25KA ~ 360KA**

4IJ15A-AULA Round Shaft Type

Weight (Mass): 3.1 lb.(1.4 kg)

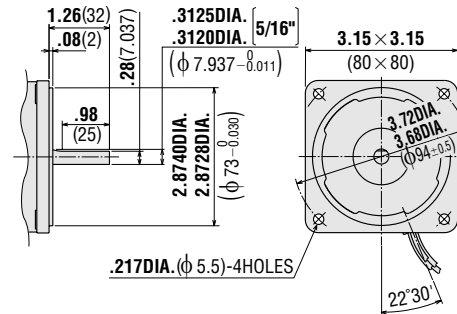

● Decimal Gearhead

4GB10XK Weight (Mass): 0.77 lb.(0.35 kg)

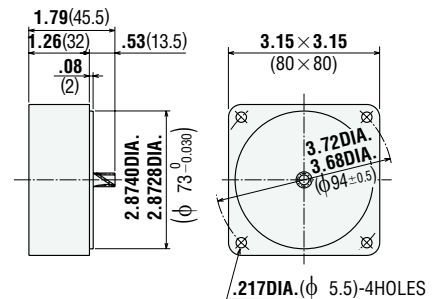

● **Capacitor** (included with the motor)

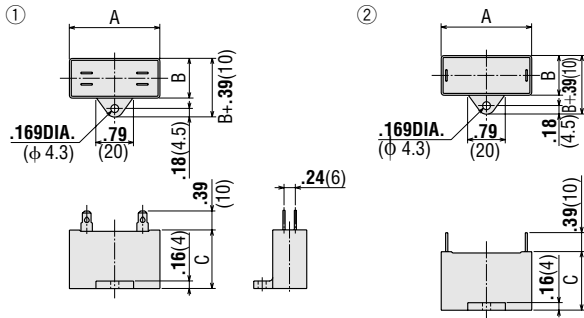

| Motor Model | Capacitor Model | Dimensions inch (mm) | | | Weight (Mass) oz (g) | Dimension No. |
|---------------------|-----------------|----------------------|------|------|----------------------|---------------|
| | | A | B | C | | |
| 3IK15GN-AW□U | CH45FAUL | 1.46 | .71 | 1.06 | 1.06 (30) | ① |
| 3IK15A-AW□U | | (37) | (18) | (27) | | |
| 3IK15GN-CW□E | CH10BFAUL | 1.46 | .71 | 1.06 | 1.06 (30) | ① |
| 3IK15A-CW□E | | (37) | (18) | (27) | | |
| 3IK15GN-AUL | CH40UL | 1.46 | .71 | 1.06 | 0.92 (26) | ② |
| 3IK15A-AULA | | (37) | (18) | (27) | | |
| 4IJ15GB-AUL | CH30UL | 1.22 | .67 | 1.06 | 0.71 (20) | ② |
| 4IJ15A-AULA | | (31) | (17) | (27) | | |

If you need to order a capacitor without a motor, add "-C" to the capacitor model number shown. A capacitor cap is always included with a capacitor.

■ **Wiring Diagrams** The direction of motor rotation is as viewed from the shaft end of the motor.

| Model | Lead Wire Type | |
|-----------|---|--|
| | 3IK15GN-AWU 3IK15GN-CWE | 3IK15GN-AUL 4IJ15GB-AUL |
| Direction | | |
| CW | | |
| CCW | <p>To rotate the motor in a clockwise (CW) direction, flip switch SW to CW.</p> <p>To rotate it in a counterclockwise (CCW) direction, flip switch SW to CCW.</p> | |

Change the direction of motor rotation only after bringing the motor to a stop. If an attempt is made to change the direction of rotation while the motor is rotating, the motor may ignore the reversing command or change its direction of rotation after some delay.

■ **Accessories**

● **Motor Mounting Brackets**

Optional die-cast aluminum mounting brackets are available. They can be used to install motors with or without gearheads. See page [A-266] for the dimensions.

Model name **SOL3U10**
SOL4U10



● **Flexible Coupling**

Optional clamping couplings are available. See page [A-260] for the dimensions.



INDUCTION MOTORS

Single-Phase, Three-Phase

25w (1/30 HP)

Frame Size 3.15 in.sq.(80mm sq.)



Specifications — Continuous Rating



| Model Upper Model Name:Pinion Shaft Type Lower Model Name():Round Shaft Type | | | Output Power | Voltage | Frequency | Current | Starting Torque | Rated Torque | Rated Speed | Capacitor | | | | |
|---|----------------------------------|---------------------------------|------------------------------|---------|-----------|------------------|-----------------|---------------|---------------|-----------|------|-----|------|-----|
| Lead Wire Type Dimension ① | Terminal Box Type Dimension ② | Conduit Box Type Dimension ③ | HP | W | V | Hz | A | oz-in mN·m | oz-in mN·m | r/min | μF | | | |
| UL VDE | 4IK25GN-AWU (4IK25A-AWU) | 4IK25GN-AWTU (4IK25A-AWTU) | 4IK25GN-FCH (4IK25AA-FCH) | 1/30 | 25 | Single-Phase 110 | 60 | 0.46 | 16.7 | 120 | 23.6 | 170 | 1450 | 6.5 |
| | | | | | | Single-Phase 115 | 60 | | | | | | | |
| UL VDE | 4IK25GN-CWE (4IK25A-CWE) | 4IK25GN-CWTE (4IK25A-CWTE) | 4IK25GN-ECH (4IK25AA-ECH) | 1/30 | 25 | Single-Phase 220 | 60 | 0.22 | | 120 | 23.6 | 170 | 1450 | 1.5 |
| | | | | | | Single-Phase 230 | 50 | 0.24 | 16.7 | 120 | 28.5 | 205 | 1200 | |
| UL VDE | 4IK25GN-SW (4IK25A-SW) | 4IK25GN-SWT (4IK25A-SWT) | 4IK25GN-SH (4IK25AA-SH) | 1/30 | 25 | Three-Phase 200 | 50 | 0.23 | 33.3 | 240 | 26.4 | 190 | 1300 | — |
| | | | | | | Three-Phase 200 | 60 | 0.21 | 22.2 | 160 | 22.2 | 160 | 1550 | |
| | | | | | | Three-Phase 220 | 60 | 0.21 | 22.2 | 160 | 22.2 | 160 | 1600 | |
| | | | | | | Three-Phase 230 | 60 | 0.22 | 22.2 | 160 | 22.2 | 160 | 1600 | |
| UL VDE | 4IK25GN-AUL (4IK25A-AULA) | — | — | 1/30 | 25 | Single-Phase 115 | 60 | 0.49 | 15.3 | 110 | 22.9 | 165 | 1500 | 4.5 |

- The product contains a built-in thermal protector. When a motor overheats for any reason, the thermal protector is opened and the motor stops. When the motor temperature drops, the thermal protector closes and the motor restarts. Be sure to turn the motor off before inspecting.
- The "U" and "E" at the end of the model name indicate that the unit includes a capacitor. These two letters are not listed on the motor nameplate. When the motor is approved under various safety standards, the nameplate is adopted.
- The conduit box type of the motors are not VDE approved.

Gearmotor — Torque Table

The maximum permissible torque with a decimal gearhead with a gear ratio of 10 is 69 lb-in (8N·m). The value is 52 lb-in (6N·m) when 25:1~36:1 gearheads are connected.

- Right-Angle gearhead may be connected. See page [A-216] for more information on the right-angle gearheads.

Single-Phase 115V/230V, Three-Phase 230V 60Hz

Unit = Upper values: lb-in / Lower values: N·m

| Model | Speed r/min Gear Ratio | 600 | 500 | 360 | 300 | 240 | 200 | 144 | 120 | 100 | 72 | 60 | 50 | 36 | 30 | 24 | 20 | 18 | 15 | 12 | 10 | |
|--|---------------------------|----------|------------|----------|----------|------------|----------|-------------|-----------|-----------|-----------|-----------|-----------|-----------|-----------|-----------|-----------|------------|------------|------------|------------|----|
| | | 3 | 3.6 | 5 | 6 | 7.5 | 9 | 12.5 | 15 | 18 | 25 | 30 | 36 | 50 | 60 | 75 | 90 | 100 | 120 | 150 | 180 | |
| 4IK25GN-AWU 4IK25GN-AWTU 4IK25GN-CWE 4IK25GN-CWTE 4IK25GN-FCH 4IK25GN-ECH | 4GN□KA | 3.6 | 4.3 | 6.0 | 7.2 | 9.0 | 11 | 15 | 18 | 22 | 27 | 32 | 39 | 49 | 58 | 69 | 69 | 69 | 69 | 69 | 69 | |
| | | 0.41 | 0.50 | 0.69 | 0.83 | 1.0 | 1.2 | 1.7 | 2.1 | 2.5 | 3.1 | 3.7 | 4.5 | 5.6 | 6.7 | 8 | 8 | 8 | 8 | 8 | 8 | |
| | | 3.4 | 4.0 | 5.6 | 6.7 | 8.4 | 10 | 14 | 17 | 20 | 25 | 30 | 36 | 46 | 55 | 69 | 69 | 69 | 69 | 69 | 69 | 69 |
| | | 0.39 | 0.47 | 0.65 | 0.78 | 0.97 | 1.2 | 1.6 | 1.9 | 2.3 | 2.9 | 3.5 | 4.2 | 5.3 | 6.3 | 7.9 | 8 | 8 | 8 | 8 | 8 | 8 |
| | | 3.5 | 4.2 | 5.8 | 7.0 | 8.7 | 10 | 14 | 17 | 21 | 26 | 31 | 38 | 47 | 57 | 69 | 69 | 69 | 69 | 69 | 69 | 69 |
| 4IK25GN-AUL / 4GN□KA | | 0.40 | 0.48 | 0.67 | 0.80 | 1.0 | 1.2 | 1.7 | 2.0 | 2.4 | 3.0 | 3.6 | 4.3 | 5.4 | 6.5 | 8 | 8 | 8 | 8 | 8 | 8 | |

Single-Phase 230V 50Hz

Unit = Upper values: lb-in / Lower values: N·m

| Model | Speed r/min Gear Ratio | 500 | 416 | 300 | 250 | 200 | 166 | 120 | 100 | 83 | 60 | 50 | 41 | 30 | 25 | 20 | 16 | 15 | 12.5 | 10 | 8.3 |
|--|---------------------------|----------|------------|----------|----------|------------|----------|-------------|-----------|-----------|-----------|-----------|-----------|-----------|-----------|-----------|-----------|------------|------------|------------|------------|
| | | 3 | 3.6 | 5 | 6 | 7.5 | 9 | 12.5 | 15 | 18 | 25 | 30 | 36 | 50 | 60 | 75 | 90 | 100 | 120 | 150 | 180 |
| 4IK25GN-CWE 4IK25GN-CWTE 4IK25GN-ECH | 4GN□KA | 4.3 | 5.2 | 7.2 | 8.7 | 11 | 13 | 18 | 22 | 26 | 33 | 39 | 47 | 59 | 69 | 69 | 69 | 69 | 69 | 69 | 69 |
| | | 0.50 | 0.60 | 0.83 | 1.0 | 1.2 | 1.5 | 2.1 | 2.5 | 3.0 | 3.7 | 4.5 | 5.4 | 6.8 | 8 | 8 | 8 | 8 | 8 | 8 | 8 |

- Gearheads are sold separately.
- Enter the gear ratio in the box (□) within the model number. A colored background indicates gear shaft rotation in the same direction as the motor shaft; a white background indicates rotation in the opposite direction.
- The speed is calculated by dividing the motor's synchronous speed (50 Hz: 1500r/min, 60 Hz: 1800 r/min) by the gear ratio. The actual speed is 2 ~ 20% less than the displayed value, depending on the size of the load.

■ Dimensions Scale 1/4, Unit = inch (mm)

① Motor/Gearhead

4IK25GN-AWU
4IK25GN-CWE
4IK25GN-SW
4IK25GN-AUL

Weight (Mass): 3.3 lb.(1.5 kg)

4GN□KA

Weight (Mass): 1.43 lb.(0.65 kg)

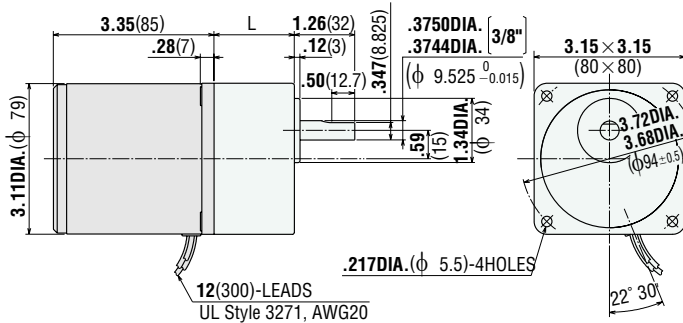

L=1.26 (32) **4GN3KA~18KA**
 L=1.67 (42.5) **4GN25KA~180KA**

4IK25A-AWU Round Shaft Type

4IK25A-CWE
4IK25A-SW
4IK25A-AULA

Weight (Mass): 3.3 lb.(1.5 kg)

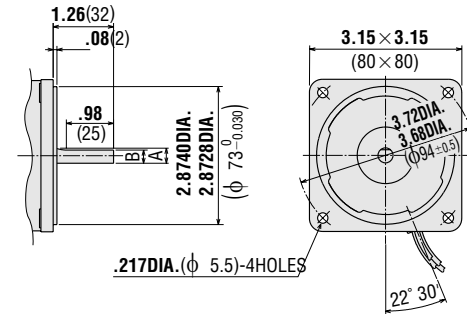

Unit = inch (mm)

| Model | Shaft Diameter A | B |
|---------------------------------------|---|------------|
| 4IK25A-AWU | .3150DIA. (φ 8 ⁰ _{-0.015}) | .28(7) |
| 4IK25A-CWE 4IK25A-SW | .3144DIA. (φ 8 ⁰ _{-0.015}) | .28(7) |
| 4IK25A-AULA | .3125DIA. [5/16"] (φ 7.937 ⁰ _{-0.011}) | .28(7.037) |

② Motor/Gearhead

4IK25GN-AWTU
4IK25GN-CWTE
4IK25GN-SWT

Weight (Mass): 3.7 lb.(1.7 kg)

4GN□KA

Weight (Mass): 1.43 lb.(0.65 kg)

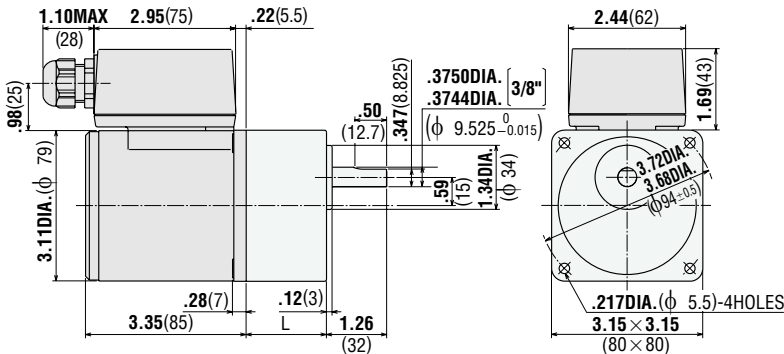

L=1.26 (32) **4GN3KA~18KA**
 L=1.67 (42.5) **4GN25KA~180KA**

Use cabtyre cable with the diameter of .24DIA.(φ 6)~.47DIA.(φ 12).

4IK25A-AWTU Round Shaft Type

4IK25A-CWTE
4IK25A-SWT

Weight (Mass): 3.7 lb.(1.7 kg)

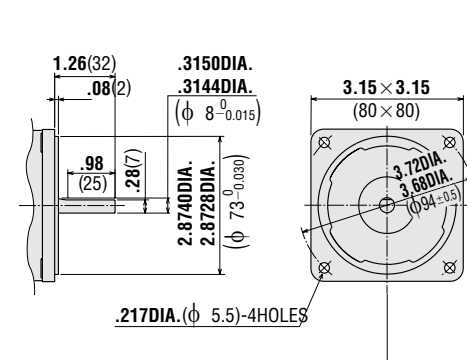

③ Motor/Gearhead

4IK25GN-FCH
4IK25GN-ECH

Weight (Mass): 4.2 lb.(1.9 kg)

4GN□KA

Weight (Mass): 1.43 lb.(0.65 kg)

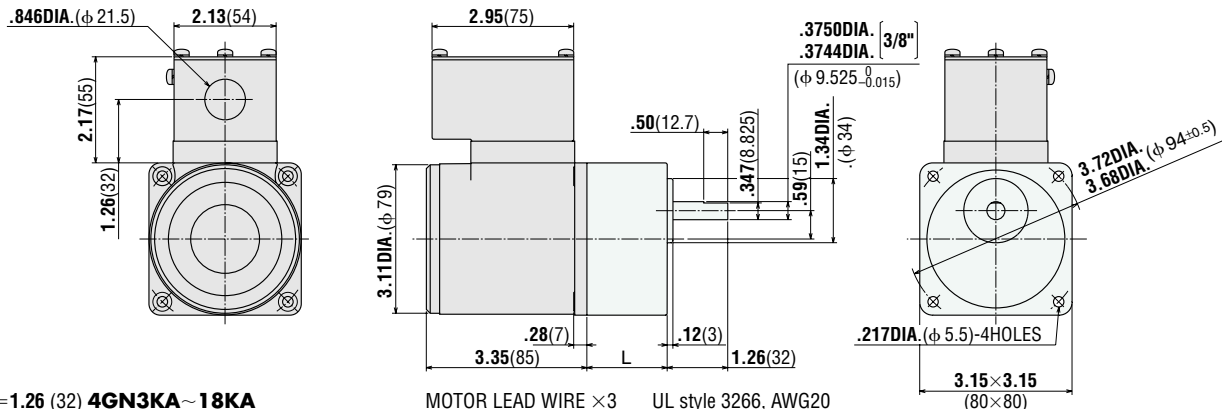

L=1.26 (32) **4GN3KA~18KA**
 L=1.67 (42.5) **4GN25KA~180KA**

MOTOR LEAD WIRE ×3 UL style 3266, AWG20
 GROUND LEAD WIRE ×1 UL style 3266, AWG18

4IK25AA-FCH Round Shaft Type
4IK25AA-ECH

Weight (Mass): 4.2 lb.(1.9 kg)

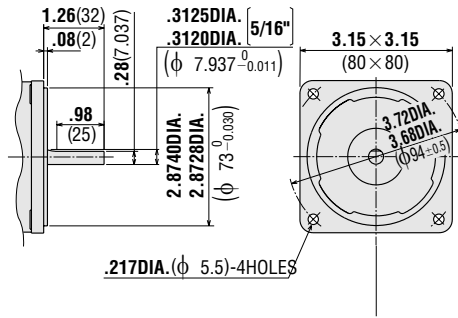

4IK25GN-SH / **4GN□KA**

Weight (Mass): 3.7 lb.(1.7 kg) / Weight (Mass): 1.43 lb.(0.65 kg)

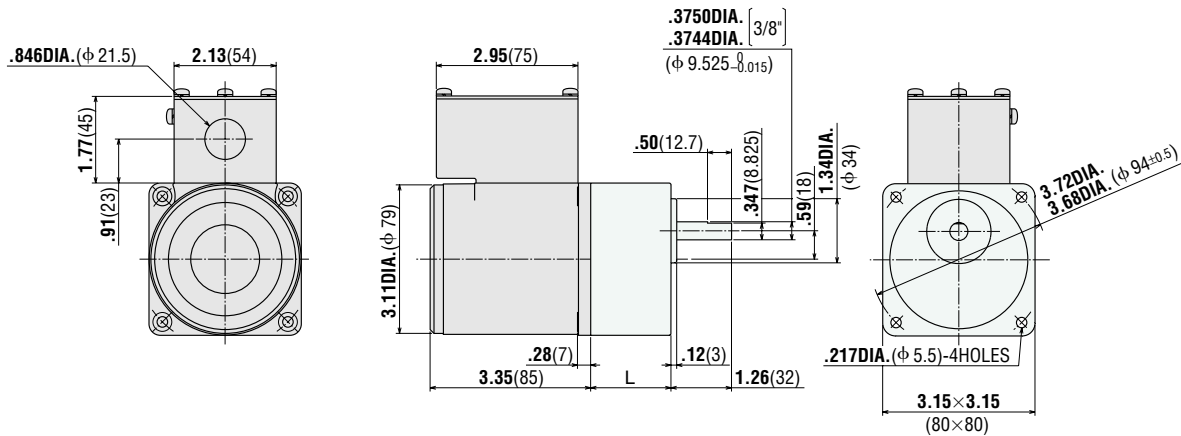

L=1.26 (32) **4GN3KA~18KA**
 L=1.67 (42.5) **4GN25KA~180KA**

MOTOR LEAD WIRE ×3 UL style 3266, AWG20
 GROUND LEAD WIRE ×1 UL style 3266, AWG18

4IK25AA-SH Round Shaft Type

Weight (Mass): 3.7 lb.(1.7 kg)

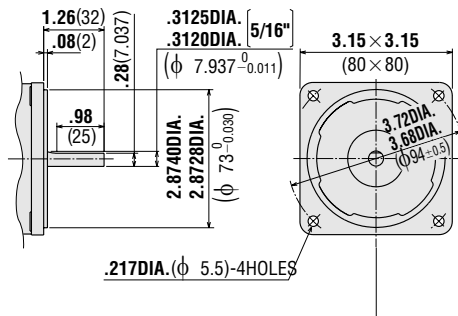

● Decimal Gearhead

4GN10XK Weight (Mass): 0.88 lb.(0.4 kg)

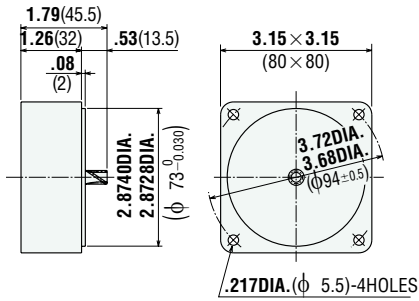

● Capacitor (included with the motor)

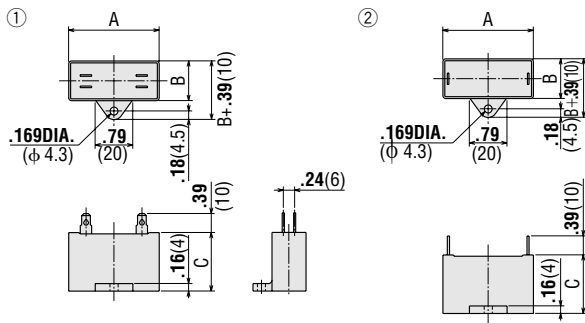

| Motor Model | Capacitor Model | Dimensions in. (mm) | | | Weight (Mass) oz (g) | Dimension No. |
|---------------------|-----------------|---------------------|--------------|--------------|----------------------|---------------|
| | | A | B | C | | |
| 4IK25GN-AW□U | CH65CFAUL | 1.50 (38) | 0.83 (21) | 1.22 (31) | 1.23 (35) | ① |
| 4IK25A-AW□U | | | | | | |
| 4IK25GN-CW□E | CH15BFAUL | 1.50 (38) | 0.83 (21) | 1.22 (31) | 1.23 (35) | ① |
| 4IK25A-CW□E | | | | | | |
| 4IK25GN-AUL | CH45UL | 1.46 (37) | 0.71 (18) | 1.06 (27) | 0.92 (26) | ② |
| 4IK25A-AULA | | | | | | |

If you need to order a capacitor without a motor, add "-C" to the capacitor model number shown. A capacitor cap is always included with a capacitor.

■ Right-Angle Gearheads

The right-angle gearhead provides an output shaft that is at a right angle to the motor's output shaft. See page [A-216] for specifications and other information.



■ Wiring Diagrams

The direction of motor rotation is as viewed from the shaft end of the motor.

| Model Direction | Lead Wire Type | | |
|--------------------|---|--|--------------------|
| | 4IK25GN-AWU 4IK25GN-CWE | 4IK25GN-SW | 4IK25GN-AUL |
| CW | | | |
| CCW | <p>To rotate the motor in a clockwise (CW) direction, flip switch SW to CW.</p> <p>To rotate it in a counterclockwise (CCW) direction, flip switch SW to CCW.</p> | To change the rotation, change any two connections between U, V and W. | |

| Model Direction | Terminal Box Type | | Conduit Box Type | |
|--------------------|---|--|---|--|
| | 4IK25GN-AWTU 4IK25GN-CWTE | 4IK25GN-SWT | 4IK25GN-FCH 4IK25GN-ECH | 4IK25GN-SH |
| CW | | | | |
| CCW | <p>To rotate the motor in a clockwise (CW) direction, flip switch SW to CW.</p> <p>To rotate it in a counterclockwise (CCW) direction, flip switch SW to CCW.</p> | To change the rotation, change any two connections between U, V and W. | <p>To rotate the motor in a clockwise (CW) direction, flip switch SW to CW.</p> <p>To rotate it in a counterclockwise (CCW) direction, flip switch SW to CCW.</p> | To change the rotation, change any two connections between U, V and W. |

Change the direction of motor rotation only after bringing the motor to a stop.

If an attempt is made to change the direction of rotation while the motor is rotating, the motor may ignore the reversing command or change its direction of rotation after some delay.

■ Accessories

● Motor Mounting Brackets

Optional die-cast aluminum mounting brackets are available. They can be used to install motors with or without gearheads. See page [A-266] for the dimensions.

Model name **SOL4U10**



● Flexible Coupling

Optional clamping couplings are available. See page [A-260] for the dimensions.





INDUCTION MOTORS

Single-Phase, Three-Phase

40w (1/18.5 HP)

Frame Size 3.54 in.sq.(90mm sq.)



Specifications — Continuous Rating

| Model | | | Output Power | Voltage | Frequency | Current | Starting Torque | Rated Torque | Rated Speed | Capacitor | | | |
|------------------------------------|--------------------------------------|--------------------|--------------|---------|-----------|---------|-----------------|--------------|-------------|-----------|------|-------|----|
| Upper Model Name:Pinion Shaft Type | Lower Model Name():Round Shaft Type | | | | | | | | | | | | |
| Lead Wire Type | Terminal Box Type | Conduit Box Type | HP | W | V | Hz | A | oz-in | mN·m | oz-in | mN·m | r/min | μF |
| Dimension ① | Dimension ② | Dimension ③ | | | | | | | | | | | |
| 5IK40GN-AWU | 5IK40GN-AWTU | 5IK40GN-FCH | | | | | | | | | | | |
| (5IK40A-AWU) | (5IK40A-AWTU) | (5IK40AA-FCH) | | | | | | | | | | | |
| 5IK40GN-CWE | 5IK40GN-CWTE | 5IK40GN-ECH | | | | | | | | | | | |
| (5IK40A-CWE) | (5IK40A-CWTE) | (5IK40AA-ECH) | | | | | | | | | | | |
| 5IK40GN-SW | 5IK40GN-SWT | 5IK40GN-SH | | | | | | | | | | | |
| (5IK40A-SW) | (5IK40A-SWT) | (5IK40AA-SH) | | | | | | | | | | | |
| 5IK40GN-AUL | — | — | | | | | | | | | | | |
| (5IK40A-AULA) | | | | | | | | | | | | | |

- The product contains a built-in thermal protector. When a motor overheats for any reason, the thermal protector is opened and the motor stops. When the motor temperature drops, the thermal protector closes and the motor restarts. Be sure to turn the motor off before inspecting.
- The "U" and "E" at the end of the model name indicate that the unit includes a capacitor. These two letters are not listed on the motor nameplate. When the motor is approved under various safety standards, the nameplate is adopted.
- The conduit box type of the motors are not VDE approved.

Gearmotor — Torque Table

The maximum permissible torque with a decimal gearhead with a gear ratio of 10 is 87 lb-in (10N·m).

- Right-Angle gearhead may be connected. See page [A-216] for more information on the right-angle gearheads.

Single-Phase 115V/230V, Three-Phase 230V 60Hz

Unit = Upper values: lb-in / Lower values: N·m

| Model | Speed r/min | Gear Ratio | | | | | | | | | | | | | | | | | | | | | |
|---------------------|---------------|------------|------------|----------|----------|------------|----------|-------------|-----------|-----------|-----------|-----------|-----------|-----------|-----------|-----------|-----------|------------|------------|------------|------------|----|--|
| | | 500 | 416 | 300 | 250 | 200 | 166 | 120 | 100 | 83 | 60 | 50 | 41 | 30 | 25 | 20 | 16 | 15 | 12.5 | 10 | 8.3 | | |
| 5IK40GN-AWU | 5GN□KA | 3 | 3.6 | 5 | 6 | 7.5 | 9 | 12.5 | 15 | 18 | 25 | 30 | 36 | 50 | 60 | 75 | 90 | 100 | 120 | 150 | 180 | | |
| 5IK40GN-AWTU | | 5.5 | 6.6 | 9.1 | 11 | 14 | 16 | 23 | 27 | 33 | 41 | 49 | 59 | 74 | 87 | 87 | 87 | 87 | 87 | 87 | 87 | 87 | |
| 5IK40GN-CWE | | 0.63 | 0.76 | 1.1 | 1.3 | 1.6 | 1.9 | 2.6 | 3.2 | 3.8 | 4.7 | 5.7 | 6.8 | 8.6 | 10 | 10 | 10 | 10 | 10 | 10 | 10 | 10 | |
| 5IK40GN-CWTE | | | | | | | | | | | | | | | | | | | | | | | |
| 5IK40GN-SW | | | | | | | | | | | | | | | | | | | | | | | |
| 5IK40GN-SWT | | | | | | | | | | | | | | | | | | | | | | | |
| 5IK40GN-FCH | | | | | | | | | | | | | | | | | | | | | | | |
| 5IK40GN-ECH | | | | | | | | | | | | | | | | | | | | | | | |
| 5IK40GN-SH | | | | | | | | | | | | | | | | | | | | | | | |
| 5IK40GN-AUL | | | | | | | | | | | | | | | | | | | | | | | |

Single-Phase 230V/50Hz

Unit = Upper values: lb-in / Lower values: N·m

| Model | Speed r/min | Gear Ratio | | | | | | | | | | | | | | | | | | | | |
|---------------------|---------------|------------|------|-----|-----|-----|-----|-----|-----|-----|-----|-----|-----|-----|----|----|----|----|------|----|-----|----|
| | | 500 | 416 | 300 | 250 | 200 | 166 | 120 | 100 | 83 | 60 | 50 | 41 | 30 | 25 | 20 | 16 | 15 | 12.5 | 10 | 8.3 | |
| 5IK40GN-CWE | 5GN□KA | 6.3 | 7.6 | 11 | 13 | 16 | 19 | 26 | 32 | 38 | 48 | 57 | 68 | 86 | 87 | 87 | 87 | 87 | 87 | 87 | 87 | 87 |
| 5IK40GN-CWTE | | 0.73 | 0.87 | 1.2 | 1.5 | 1.8 | 2.2 | 3.0 | 3.6 | 4.4 | 5.5 | 6.6 | 7.9 | 9.9 | 10 | 10 | 10 | 10 | 10 | 10 | 10 | 10 |
| 5IK40GN-ECH | | | | | | | | | | | | | | | | | | | | | | |

- Gearheads are sold separately.
- Enter the gear ratio in the box (□) within the model number. A colored background indicates gear shaft rotation in the same direction as the motor shaft; a white background indicates rotation in the opposite direction.
- The speed is calculated by dividing the motor's synchronous speed (50 Hz: 1500r/min, 60 Hz: 1800 r/min) by the gear ratio. The actual speed is 2 ~ 20% less than the displayed value, depending on the size of the load.

■ Dimensions Scale 1/4, Unit = inch (mm)

① Motor/Gearhead

51K40GN-AWU
51K40GN-CWE
51K40GN-SW
51K40GN-AUL

Weight (Mass): 5.5 lb.(2.5 kg)

5GN□KA

Weight (Mass): 3.3 lb.(1.5 kg)

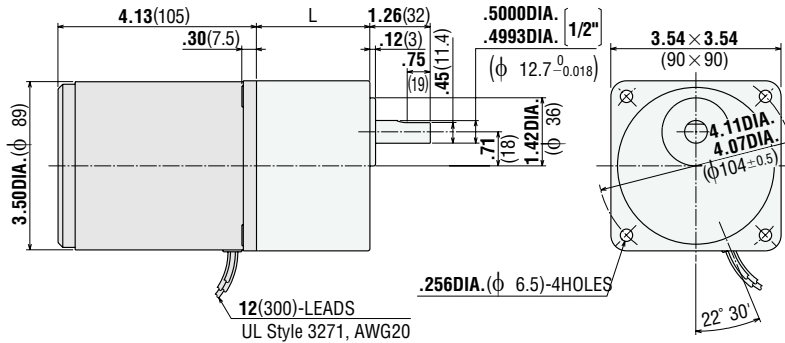

L=1.65 (42) **5GN3KA~18KA**
 L=2.36 (60) **5GN25KA~180KA**

51K40A-AWU Round Shaft Type
51K40A-CWE
51K40A-SW
51K40A-AULA

Weight (Mass): 5.5 lb.(2.5 kg)

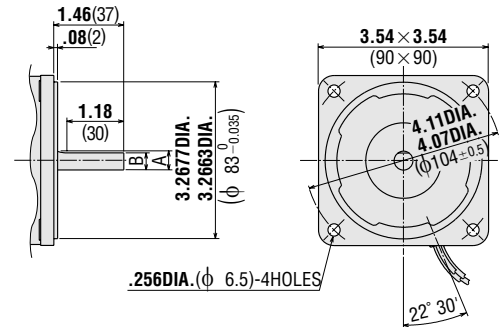

Unit = inch (mm)

| Model | Shaft Diameter A | B |
|--------------------|--|------------|
| 51K40A-AWU | .3937DIA. ($\phi 10_{-0.015}$) | .35(9) |
| 51K40A-CWE | .3931DIA. | |
| 51K40A-SW | | |
| 51K40A-AULA | .3750DIA. [$3/8$ "] ($\phi 9.525_{-0.011}$) | .35(8.825) |

② Motor/Gearhead

51K40GN-AWTU
51K40GN-CWTE
51K40GN-SWT

Weight (Mass): 5.7 lb.(2.6 kg)

5GN□KA

Weight (Mass): 3.3 lb.(1.5 kg)

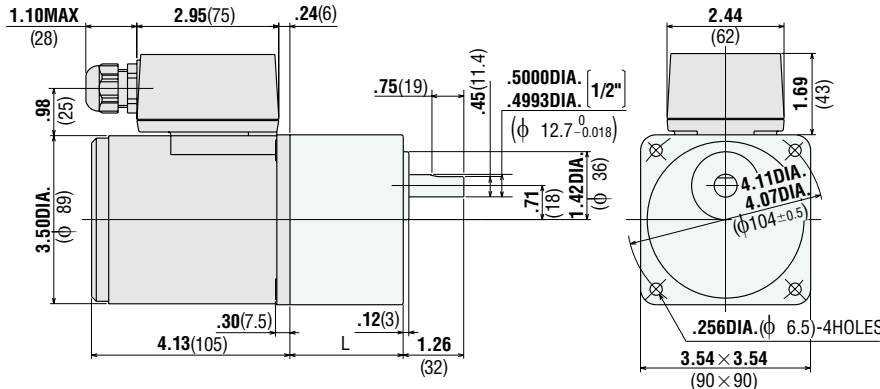

L=1.65 (42) **5GN3KA~18KA**
 L=2.36 (60) **5GN25KA~180KA**

Use cabtyre cable with the diameter of
 .24DIA. ($\phi 6$)~.47DIA. ($\phi 12$).

51K40A-AWTU Round Shaft Type
51K40A-CWTE
51K40A-SWT

Weight (Mass): 5.7 lb.(2.6 kg)

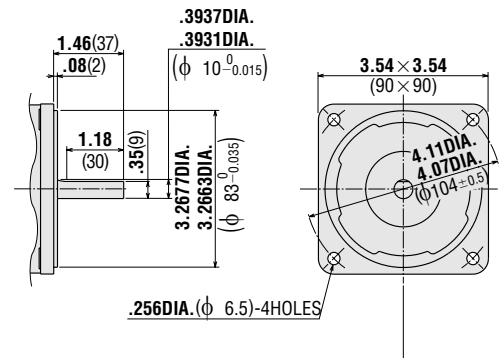

③ Motor/Gearhead

51K40GN-FCH
51K40GN-ECH

Weight (Mass): 6.0 lb.(2.7 kg)

5GN□KA

Weight (Mass): 3.3 lb.(1.5 kg)

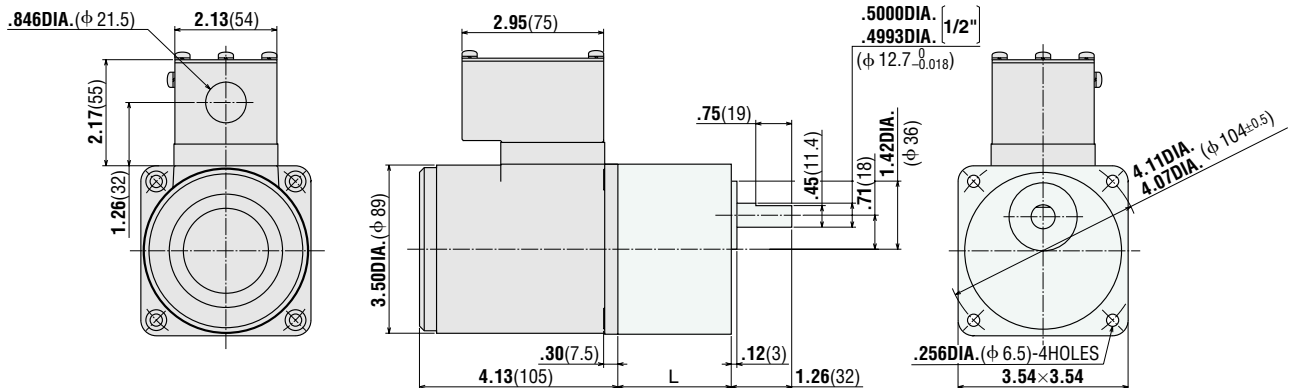

L=1.65 (42) **5GN3KA~18KA**
 L=2.36 (60) **5GN25KA~180KA**

MOTOR LEAD WIRE ×3 UL style 3266, AWG20
 GROUND LEAD WIRE ×1 UL style 3266, AWG18

5IK40AA-FCH Round Shaft Type
5IK40AA-ECH

Weight (Mass): 6.0 lb.(2.7 kg)

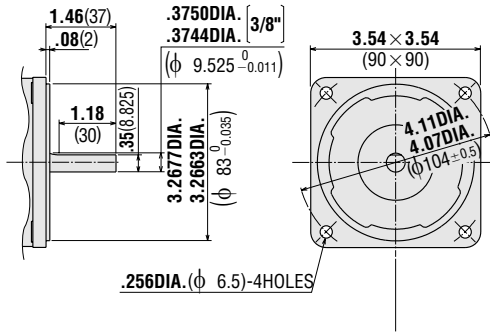

5IK40GN-SH / **5GN□KA**

Weight (Mass): 5.5 lb.(2.5 kg) / Weight (Mass): 3.31 lb.(1.5 kg)

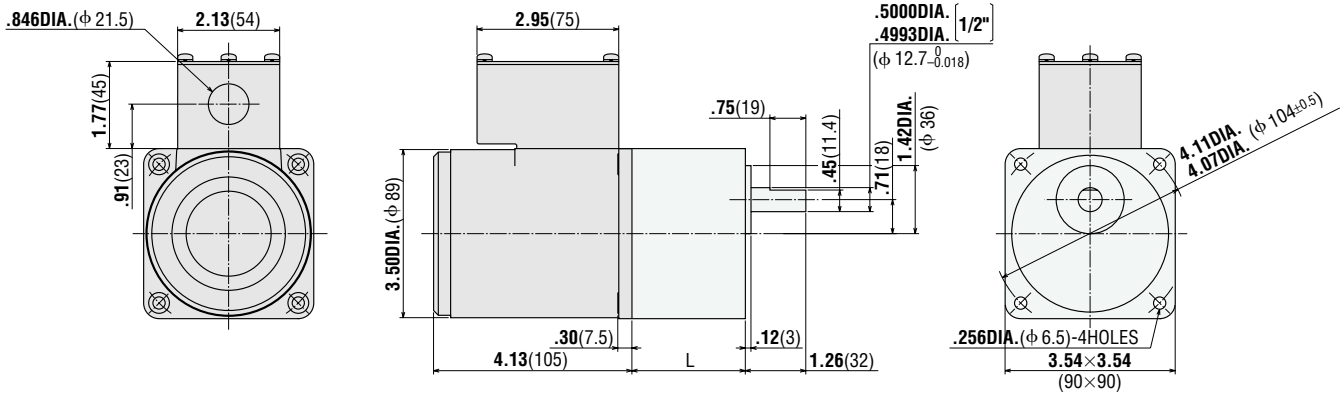

L=1.65 (42) **5GN3KA~18KA**
 L=2.36 (60) **5GN25KA~180KA**

MOTOR LEAD WIRE ×3 UL style 3266, AWG20
 GROUND LEAD WIRE ×1 UL style 3266, AWG18

5IK40AA-SH Round Shaft Type

Weight (Mass): 5.5 lb.(2.5 kg)

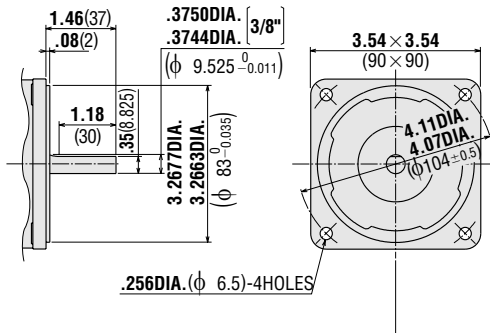

● Decimal Gearhead

5GN10XK Weight: 1.32 lb.(0.6 kg)

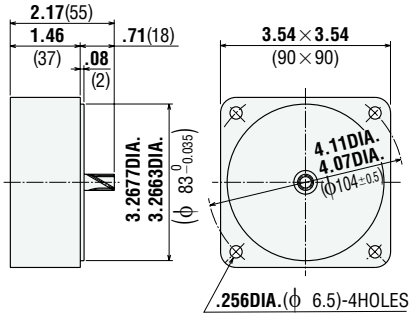

● Capacitor (included with the motor)

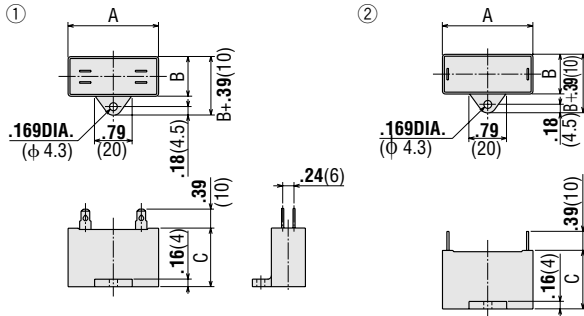

| Motor Model | Capacitor Model | Dimensions in. (mm) | | | Weight (Mass) oz (g) | Dimension No. |
|---------------------|-----------------|---------------------|------|------|----------------------|---------------|
| | | A | B | C | | |
| 5IK40GN-AW□U | CH90CFAUL | 1.89 | 0.83 | 1.22 | 1.41 (40) | ① |
| 5IK40A-AW□U | | (48) | (21) | (31) | | |
| 5IK40GN-CW□E | CH23BFAUL | 1.89 | 0.83 | 1.22 | 1.41 (40) | ① |
| 5IK40A-CW□E | | (48) | (21) | (31) | | |
| 5IK40GN-AUL | CH80UL | 1.50 | 0.83 | 1.22 | 1.23 (35) | ② |
| 5IK40A-AULA | | (38) | (21) | (31) | | |

If you need to order a capacitor without a motor, add "-C" to the capacitor model number shown. A capacitor cap is always included with a capacitor.

■ Right-Angle Gearheads

The right-angle gearhead provides an output shaft that is at a right angle to the motor's output shaft. See page [A-216] for specifications and other information.

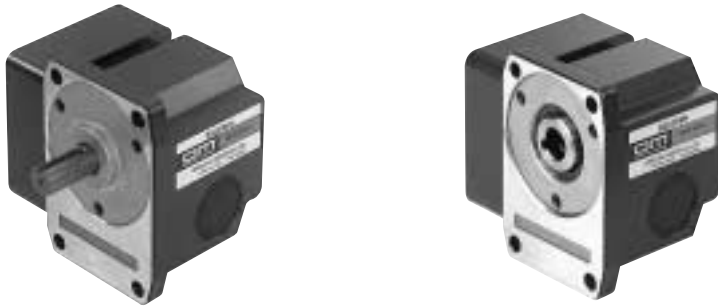

■ Wiring Diagrams

The direction of motor rotation is as viewed from the shaft end of the motor.

| Model Direction | Lead Wire Type | | |
|--------------------|--|--|--------------------|
| | 5IK40GN-AWU 5IK40GN-CWE | 5IK40GN-SW | 5IK40GN-AUL |
| CW | | | |
| CCW | To rotate the motor in a clockwise (CW) direction, flip switch SW to CW. To rotate it in a counterclockwise (CCW) direction, flip switch SW to CCW. | To change the rotation, change any two connections between U, V and W. | |

| Model Direction | Terminal Box Type | | Conduit Box Type | |
|--------------------|--|--|--|--|
| | 5IK40GN-AWTU 5IK40GN-CWTE | 5IK40GN-SWT | 5IK40GN-FCH 5IK40GN-ECH | 5IK40GN-SH |
| CW | | | | |
| CCW | To rotate the motor in a clockwise (CW) direction, flip switch SW to CW. To rotate it in a counterclockwise (CCW) direction, flip switch SW to CCW. | To change the rotation, change any two connections between U, V and W. | To rotate the motor in a clockwise (CW) direction, flip switch SW to CW. To rotate it in a counterclockwise (CCW) direction, flip switch SW to CCW. | To change the rotation, change any two connections between U, V and W. |

Change the direction of motor rotation only after bringing the motor to a stop.

If an attempt is made to change the direction of rotation while the motor is rotating, the motor may ignore the reversing command or change its direction of rotation after some delay.

■ Accessories

● Motor Mounting Brackets

Optional die-cast aluminum mounting brackets are available. They can be used to install motors with or without gearheads. See page [A-266] for the dimensions.

Model name **SOL5UA**



● Flexible Coupling

Optional clamping couplings are available. See page [A-260] for the dimensions.



INDUCTION MOTORS

Single-Phase, Three-Phase

60W (1/12.5 HP)

Frame Size 3.54 in.sq.(90mm sq.)



Specifications — Continuous Rating



| Model | | | Output Power | Voltage | Frequency | Current | Starting Torque | Rated Torque | Rated Speed | Capacitor | | | | | | |
|------------------------------------|--------------------------------------|-------------------------------|-----------------------------|---------|-----------|---------|-----------------|--------------|-------------|-----------|------|-------|----|------------------|----|------|
| Upper Model Name:Pinion Shaft Type | Lower Model Name():Round Shaft Type | | | | | | | | | | | | | | | |
| Lead Wire Type Dimension ① | Terminal Box Type Dimension ② | Conduit Box Type Dimension ③ | HP | W | V | Hz | A | oz-in | mN·m | oz-in | mN·m | r/min | μF | | | |
| UL VDE | 5IK60GU-AWU (5IK60A-AWU) | 5IK60GU-AWTU (5IK60A-AWTU) | 5IK60GU-FCH (5IK60A-FCH) | 110 | 60 | 60 | 1.09 | 44.4 | 320 | 56.2 | 405 | 1450 | 18 | | | |
| | | | | | | | | | | | | | | Single-Phase 115 | 60 | 1.1 |
| UL VDE | 5IK60GU-CWE (5IK60A-CWE) | 5IK60GU-CWTE (5IK60A-CWTE) | 5IK60GU-ECH (5IK60A-ECH) | 220 | 60 | 60 | 0.54 | 44.4 | 320 | 56.2 | 405 | 1450 | 4 | | | |
| | | | | | | | | | | | | | | Single-Phase 230 | 50 | 0.57 |
| UL VDE | 5IK60GU-SW (5IK60A-SW) | 5IK60GU-SWT (5IK60A-SWT) | 5IK60GU-SH (5IK60A-SH) | 200 | 60 | 50 | 0.5 | 83.3 | 600 | 62.5 | 450 | 1300 | — | | | |
| | | | | | | | | | | | | | | Three-Phase 200 | 60 | 0.43 |
| | | | | | | | | | | | | | | Three-Phase 220 | 60 | 0.45 |
| | | | | | | | | | | | | | | Three-Phase 230 | 60 | 0.46 |
| UL VDE | 5IK60GU-AFUL (5IK60A-AFUL) | — | — | 115 | 60 | 60 | 0.96 | 41.7 | 300 | 52.8 | 380 | 1550 | 12 | | | |

- The product contains a built-in thermal protector. When a motor overheats for any reason, the thermal protector is opened and the motor stops. When the motor temperature drops, the thermal protector closes and the motor restarts. Be sure to turn the motor off before inspecting.
- The "U" and "E" at the end of the model name indicate that the unit includes a capacitor. These two letters are not listed on the motor nameplate. When the motor is approved under various safety standards, the nameplate is adopted.
- The conduit box type of the motors are not VDE approved.

Gearmotor — Torque Table

The maximum permissible torque with a decimal gearhead with a gear ratio of 10 is 174 lb-in (20N·m).

- Right-Angle gearhead may be connected. See page [A-216] for more information on the right-angle gearheads.

Single-Phase 115V/230V, Three-Phase 230V 60Hz

Unit = Upper values: lb-in / Lower values: N·m

| Model | Speed r/min Gear Ratio | 600 | 500 | 360 | 300 | 240 | 200 | 144 | 120 | 100 | 72 | 60 | 50 | 36 | 30 | 24 | 20 | 18 | 15 | 12 | 10 |
|--|---------------------------|---|--------|-----|-----|-----|-----|------|-----|-----|-----|-----|-----|-----|-----|-----|-----|-----|-----|-----|-----|
| | | 3 | 3.6 | 5 | 6 | 7.5 | 9 | 12.5 | 15 | 18 | 25 | 30 | 36 | 50 | 60 | 75 | 90 | 100 | 120 | 150 | 180 |
| 5IK60GU-AWU 5IK60GU-AWTU 5IK60GU-CWE 5IK60GU-CWTE 5IK60GU-FCH 5IK60GU-ECH | 5GU□KA | 8.5 | 10 | 14 | 17 | 21 | 26 | 32 | 38 | 46 | 58 | 70 | 83 | 116 | 139 | 155 | 174 | 174 | 174 | 174 | 174 |
| | | 0.98 | 1.2 | 1.6 | 2.0 | 2.5 | 3.0 | 3.7 | 4.4 | 5.3 | 6.7 | 8.0 | 9.6 | 13 | 16 | 18 | 20 | 20 | 20 | 20 | 20 |
| | | 8 | 9.6 | 13 | 16 | 20 | 24 | 30 | 36 | 43 | 54 | 65 | 78 | 109 | 131 | 146 | 174 | 174 | 174 | 174 | 174 |
| | | 0.92 | 1.1 | 1.5 | 1.8 | 2.3 | 2.8 | 3.5 | 4.2 | 5 | 6.3 | 7.5 | 9 | 13 | 15 | 17 | 20 | 20 | 20 | 20 | 20 |
| | | 5IK60GU-SW 5IK60GU-SWT 5IK60GU-SH 5IK60GU-AFUL | 5GU□KA | 8 | 9.6 | 13 | 16 | 20 | 24 | 30 | 36 | 43 | 54 | 65 | 78 | 109 | 131 | 146 | 174 | 174 | 174 |
| | | 0.92 | 1.1 | 1.5 | 1.8 | 2.3 | 2.8 | 3.5 | 4.2 | 5 | 6.3 | 7.5 | 9 | 13 | 15 | 17 | 20 | 20 | 20 | 20 | |

Single-Phase 230V/50Hz

Unit = Upper values: lb-in / Lower values: N·m

| Model | Speed r/min Gear Ratio | 500 | 416 | 300 | 250 | 200 | 166 | 120 | 100 | 83 | 60 | 50 | 41 | 30 | 25 | 20 | 16 | 15 | 12.5 | 10 | 8.3 |
|--|---------------------------|-----|-----|-----|-----|-----|-----|------|-----|-----|-----|-----|-----|-----|-----|-----|-----|-----|------|-----|-----|
| | | 3 | 3.6 | 5 | 6 | 7.5 | 9 | 12.5 | 15 | 18 | 25 | 30 | 36 | 50 | 60 | 75 | 90 | 100 | 120 | 150 | 180 |
| 5IK60GU-CWE 5IK60GU-CWTE 5IK60GU-ECH | 5GU□KA | 10 | 12 | 17 | 21 | 26 | 31 | 39 | 47 | 56 | 70 | 84 | 101 | 140 | 168 | 174 | 174 | 174 | 174 | 174 | 174 |
| | | 1.2 | 1.4 | 2.0 | 2.4 | 3.0 | 3.6 | 4.5 | 5.4 | 6.4 | 8.1 | 9.7 | 12 | 16 | 19 | 20 | 20 | 20 | 20 | 20 | 20 |

- Gearheads are sold separately.
- Enter the gear ratio in the box (□) within the model number. A colored background indicates gear shaft rotation in the same direction as the motor shaft; a white background indicates rotation in the opposite direction.
- The speed is calculated by dividing the motor's synchronous speed (50 Hz: 1500r/min, 60 Hz: 1800 r/min) by the gear ratio. The actual speed is 2 ~ 20% less than the displayed value, depending on the size of the load.

■ Dimensions Scale 1/4, Unit = inch (mm)

① Motor/Gearhead

5IK60GU-AWU
5IK60GU-CWE
5IK60GU-SW
5IK60GU-AFUL

Weight (Mass): 6.0 lb.(2.7 kg)

5GU□KA

Weight (Mass): 3.3 lb.(1.5 kg)

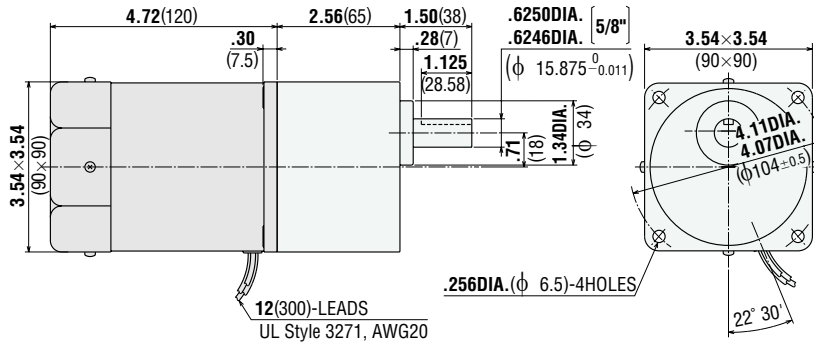

5IK60A-AWU Round Shaft Type
5IK60A-CWE
5IK60A-SW
5IK60A-AFUL

Weight (Mass): 6.0 lb.(2.7 kg)

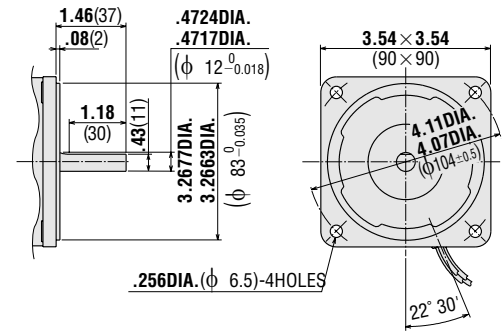

② Motor/Gearhead

5IK60GU-AWTU
5IK60GU-CWTE
5IK60GU-SWT

Weight (Mass): 6.2 lb.(2.8 kg)

5GU□KA

Weight (Mass): 3.3 lb.(1.5 kg)

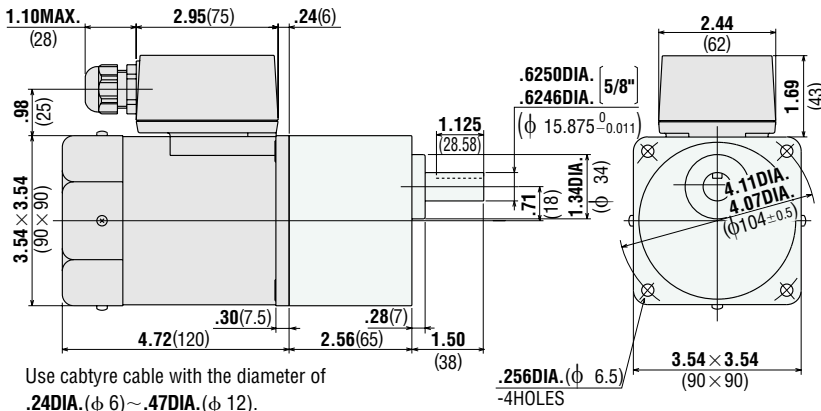

Use cabtyre cable with the diameter of
 .24DIA. (φ 6) ~ .47DIA. (φ 12).

5IK60A-AWTU Round Shaft Type
5IK60A-CWTE
5IK60A-SWT

Weight (Mass): 6.2 lb.(2.8 kg)

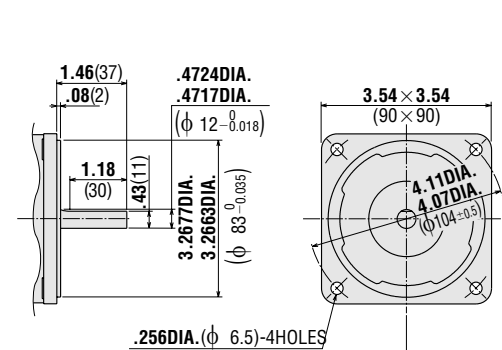

③ Motor/Gearhead

5IK60GU-FCH
5IK60GU-ECH

Weight (Mass): 7.1 lb.(3.2 kg)

5GU□KA

Weight (Mass): 3.3 lb.(1.5 kg)

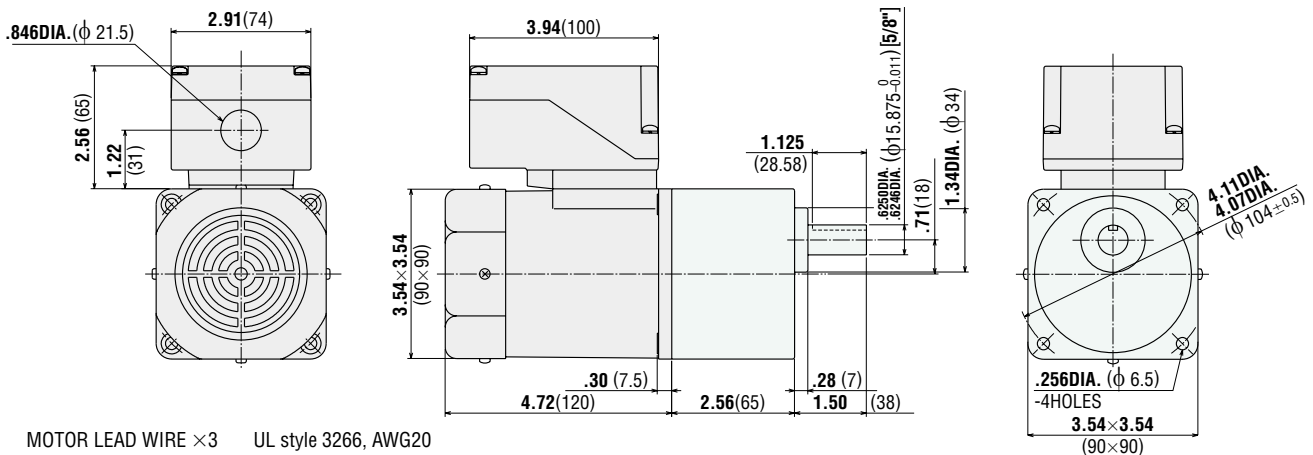

MOTOR LEAD WIRE ×3 UL style 3266, AWG20
 GROUND LEAD WIRE ×1 UL style 3266, AWG18

5IK60A-FCH
5IK60A-ECH

Weight (Mass): 7.1 lb.(3.2 kg)

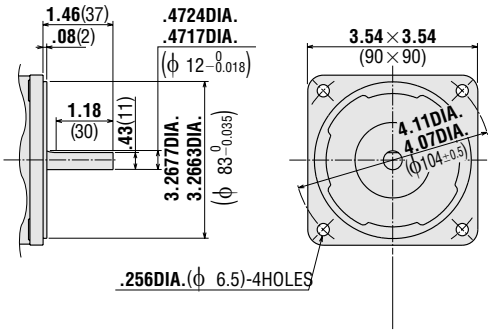

5IK60GU-SH

Weight (Mass): 6.2 lb.(2.8 kg)

5GU□KA

Weight (Mass): 3.3 lb.(1.5 kg)

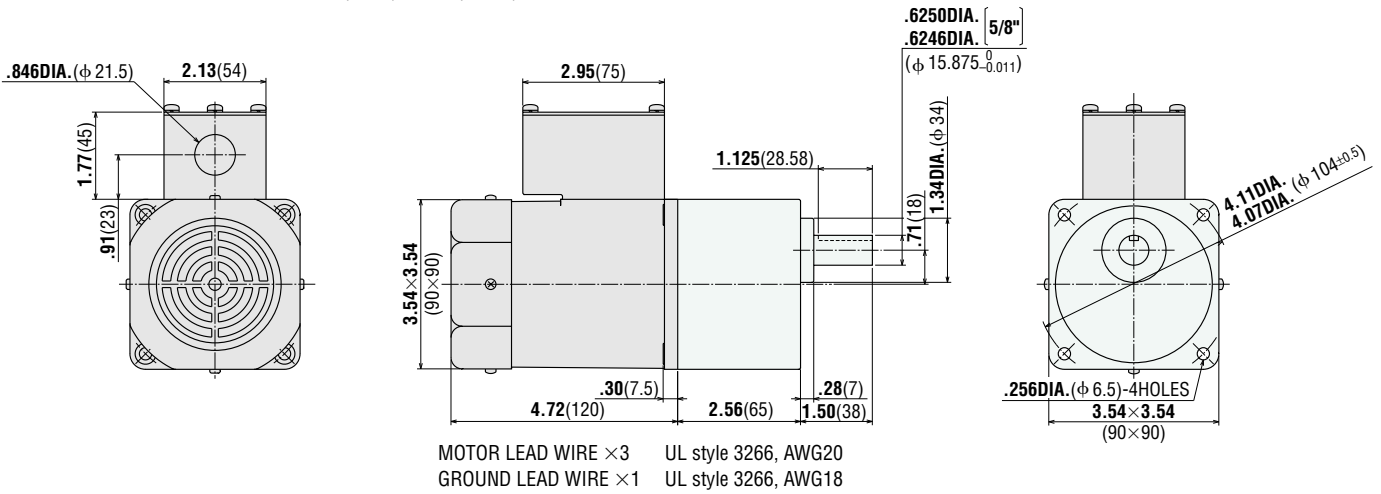

5IK60A-SH

Round Shaft Type

Weight (Mass): 6.2 lb.(2.8 kg)

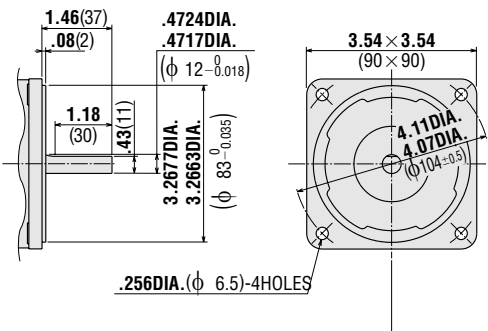

Decimal Gearhead

5GU10XKB Weight (Mass): 1.32 lb.(0.6 kg)

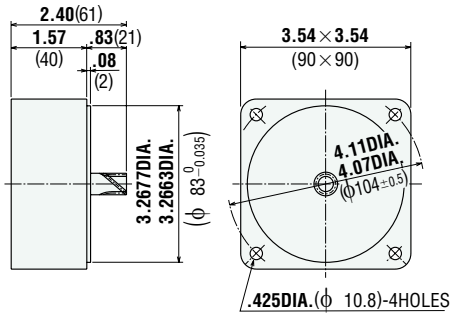

Key and Key Slot Scale 1/2

(The key is provided with the gearhead)

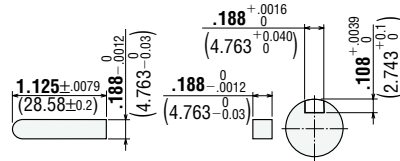

Capacitor (included with the motor)

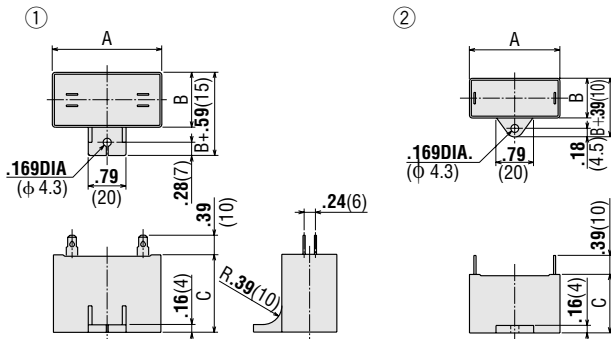

| Motor Model | Capacitor Model | Dimensions in. (mm) | | | Weight oz (g) | Dimension No. |
|----------------------|-----------------|---------------------|--------|------|---------------|---------------|
| | | A | B | C | | |
| 5IK60GU-AW □U | CH180CFAUL | 2.28 | 0.93 | 1.46 | 2.47 (70) | ① |
| 5IK60A-AW □U | | (58) | (23.5) | (37) | | |
| 5IK60GU-CW □E | CH40BFAUL | 2.28 | 0.93 | 1.46 | 2.47 (70) | ① |
| 5IK60A-CW □E | | (58) | (23.5) | (37) | | |
| 5IK60GU-AFUL | CH120CUL | 2.28 | 0.83 | 1.22 | 1.76 (50) | ② |
| 5IK60A-AFUL | | (58) | (21) | (31) | | |

If you need to order a capacitor without a motor, add "-C" to the capacitor model number shown. A capacitor cap is always included with a capacitor.

Right-Angle Gearheads

The right-angle gearhead provides an output shaft that is at a right angle to the motor's output shaft. See page [A-216] for specifications and other information.

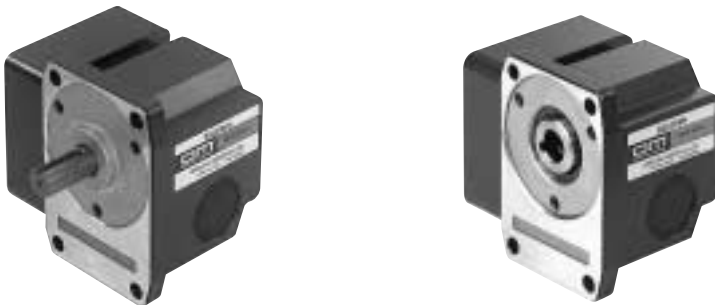

■ Wiring Diagrams

The direction of motor rotation is as viewed from the shaft end of the motor.

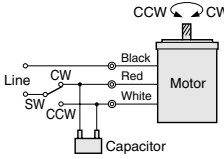
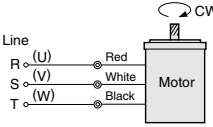
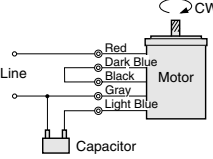
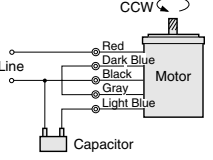
| Model Direction | Lead Wire Type | | |
|--------------------|--|---|--|
| | 5IK60GU-AWU 5IK60GU-CWE | 5IK60GU-SW | 5IK60GU-AFUL |
| CW |  |  |  |
| CCW | To rotate the motor in a clockwise (CW) direction, flip switch SW to CW. To rotate it in a counterclockwise (CCW) direction, flip switch SW to CCW. | To change the rotation, change any two connections between U, V and W. |  |

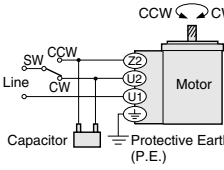
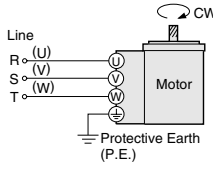
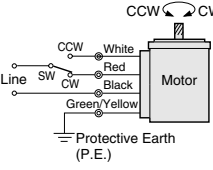
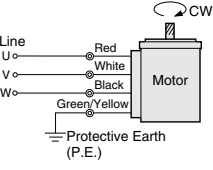
| Model Direction | Terminal Box Type | | Conduit Box Type | |
|--------------------|--|--|--|--|
| | 5IK60GU-AWTU 5IK60GU-CWTE | 5IK60GU-SWT | 5IK60GU-FCH 5IK60GU-ECH | 5IK60GU-SH |
| CW |  |  |  |  |
| CCW | To rotate the motor in a clockwise (CW) direction, flip switch SW to CW. To rotate it in a counterclockwise (CCW) direction, flip switch SW to CCW. | To change the rotation, change any two connections between U, V and W. | To rotate the motor in a clockwise (CW) direction, flip switch SW to CW. To rotate it in a counterclockwise (CCW) direction, flip switch SW to CCW. | To change the rotation, change any two connections between U, V and W. |

Change the direction of motor rotation only after bringing the motor to a stop.

If an attempt is made to change the direction of rotation while the motor is rotating, the motor may ignore the reversing command or change its direction of rotation after some delay.

■ Accessories

● Motor Mounting Brackets

Optional die-cast aluminum mounting brackets are available. They can be used to install motors with or without gearheads. See page [A-266] for the dimensions.

Model name **SOLSUA**



● Flexible Coupling

Optional clamping couplings are available. See page [A-260] for the dimensions.





INDUCTION MOTORS

Single-Phase, Three-Phase

90W (1/8 HP)

Frame Size 3.54 in.sq.(90mm sq.)



Specifications — Continuous Rating



| Model Upper Model Name:Pinion Shaft Type Lower Model Name():Round Shaft Type | | | Output Power | Voltage | Frequency | Current | Starting Torque | Rated Torque | Rated Speed | Capacitor | | |
|---|--------------------------------------|------------------------------------|------------------|---------|-----------|---------|-----------------|---------------|---------------|-----------|------|----|
| Lead Wire Type Dimension ① | Terminal Box Type Dimension ② | Conduit Box Type Dimension ③ | HP | W | V | Hz | A | oz-in mN·m | oz-in mN·m | r/min | μF | |
| 51K90GU-AWU (51K90A-AWU) | 51K90GU-AWTU (51K90A-AWTU) | 51K90GU-FCH (51K90A-FCH) | Single Phase 110 | | 60 | 1.45 | 62.5 | 450 | 81.2 | 585 | 1500 | 20 |
| | | | Single Phase 115 | | 60 | 1.44 | | | | | | |
| 51K90GU-CWE (51K90A-CWE) | 51K90GU-CWTE (51K90A-CWTE) | 51K90GU-ECH (51K90A-ECH) | Single Phase 220 | | 60 | 0.82 | 62.5 | 450 | 84 | 605 | 1450 | 6 |
| | | | Single Phase 230 | | 50 | 0.76 | 62.5 | 450 | 101.4 | 730 | 1200 | |
| Single Phase 230 | | 60 | 0.81 | 62.5 | 450 | 84 | 605 | 1450 | | | | |
| Single Phase 230 | | 60 | 0.61 | 97.2 | 700 | 79.2 | 570 | 1600 | | | | |
| 51K90GU-SW (51K90A-SW) | 51K90GU-SWT (51K90A-SWT) | 51K90GU-SH (51K90A-SH) | Three Phase 200 | | 50 | 0.64 | 118 | 850 | 94.4 | 680 | 1300 | — |
| | | | Three Phase 200 | | 60 | 0.59 | 97.2 | 700 | 79.2 | 570 | 1550 | |
| | | | Three Phase 220 | | 60 | 0.6 | 97.2 | 700 | 79.2 | 570 | 1600 | |
| | | | Three Phase 230 | | 60 | 0.61 | 97.2 | 700 | 79.2 | 570 | 1600 | |
| 51K90GU-AFUL (51K90A-AFUL) | — | — | Single Phase 115 | | 60 | 1.5 | 62.5 | 450 | 79.2 | 570 | 1550 | 20 |

- The product contains a built-in thermal protector. When a motor overheats for any reason, the thermal protector is opened and the motor stops. When the motor temperature drops, the thermal protector closes and the motor restarts. Be sure to turn the motor off before inspecting.
- The "U" and "E" at the end of the model name indicate that the unit includes a capacitor. These two letters are not listed on the motor nameplate. When the motor is approved under various safety standards, the nameplate is adopted.
- The conduit box type of the motors are not VDE approved.

Gearmotor — Torque Table

The maximum permissible torque with a decimal gearhead with a gear ratio of 10 is 174 lb-in (20N·m).

Right-Angle gearhead may be connected. See page [A-216] for more information on the right-angle gearheads.

Single-Phase 115V/230V, Three-Phase 230V 60Hz

Unit = Upper values: lb-in / Lower values: N·m

| Model | Speed r/min Gear Ratio | 600 | 500 | 360 | 300 | 240 | 200 | 144 | 120 | 100 | 72 | 60 | 50 | 36 | 30 | 24 | 20 | 18 | 15 | 12 | 10 |
|---|---------------------------|----------|------------|----------|----------|------------|----------|-------------|-----------|-----------|-----------|-----------|-----------|-----------|-----------|-----------|-----------|------------|------------|------------|------------|
| | | 3 | 3.6 | 5 | 6 | 7.5 | 9 | 12.5 | 15 | 18 | 25 | 30 | 36 | 50 | 60 | 75 | 90 | 100 | 120 | 150 | 180 |
| 51K90GU-AWU 51K90GU-AWTU / 5GU□KA 51K90GU-FCH | 12 | 15 | 21 | 25 | 31 | 37 | 46 | 56 | 67 | 84 | 100 | 121 | 167 | 174 | 174 | 174 | 174 | 174 | 174 | 174 | 174 |
| | 1.4 | 1.7 | 2.4 | 2.8 | 3.6 | 4.3 | 5.3 | 6.4 | 7.7 | 9.7 | 12 | 14 | 19 | 20 | 20 | 20 | 20 | 20 | 20 | 20 | 20 |
| 51K90GU-CWE 51K90GU-CWTE / 5GU□KA 51K90GU-ECH | 13 | 15 | 21 | 26 | 32 | 38 | 48 | 57 | 69 | 87 | 104 | 125 | 173 | 174 | 174 | 174 | 174 | 174 | 174 | 174 | 174 |
| | 1.5 | 1.8 | 2.5 | 2.9 | 3.7 | 4.4 | 5.5 | 6.6 | 7.9 | 10 | 12 | 14 | 20 | 20 | 20 | 20 | 20 | 20 | 20 | 20 | 20 |
| 51K90GU-SW 51K90GU-SWT / 5GU□KA 51K90GU-SH 51K90GU-AFUL | 12 | 14 | 20 | 24 | 30 | 36 | 45 | 54 | 65 | 82 | 98 | 118 | 163 | 174 | 174 | 174 | 174 | 174 | 174 | 174 | 174 |
| | 1.4 | 1.7 | 2.3 | 2.8 | 3.5 | 4.2 | 5.2 | 6.2 | 7.5 | 9.4 | 11 | 14 | 19 | 20 | 20 | 20 | 20 | 20 | 20 | 20 | 20 |

Single-Phase 230V/50Hz

Unit = Upper values : lb-in / Lower values : N·m

| Model | Speed r/min Gear Ratio | 500 | 416 | 300 | 250 | 200 | 166 | 120 | 100 | 83 | 60 | 50 | 41 | 30 | 25 | 20 | 16 | 15 | 12.5 | 10 | 8.3 |
|---|---------------------------|----------|------------|----------|----------|------------|----------|-------------|-----------|-----------|-----------|-----------|-----------|-----------|-----------|-----------|-----------|------------|------------|------------|------------|
| | | 3 | 3.6 | 5 | 6 | 7.5 | 9 | 12.5 | 15 | 18 | 25 | 30 | 36 | 50 | 60 | 75 | 90 | 100 | 120 | 150 | 180 |
| 51K90GU-CWE 51K90GU-CWTE / 5GU□KA 51K90GU-ECH | 15 | 18 | 26 | 31 | 39 | 46 | 58 | 69 | 83 | 105 | 125 | 151 | 174 | 174 | 174 | 174 | 174 | 174 | 174 | 174 | 174 |
| | 1.8 | 2.1 | 3.0 | 3.5 | 4.4 | 5.3 | 6.7 | 8.0 | 9.6 | 12 | 14 | 17 | 20 | 20 | 20 | 20 | 20 | 20 | 20 | 20 | 20 |

- Gearheads are sold separately.
- Enter the gear ratio in the box (□) within the model number. A colored background indicates gear shaft rotation in the same direction as the motor shaft; a white background indicates rotation in the opposite direction.
- The speed is calculated by dividing the motor's synchronous speed (50 Hz: 1500r/min, 60 Hz: 1800 r/min) by the gear ratio. The actual speed is 2 ~ 20% less than the displayed value, depending on the size of the load.

■ Dimensions Scale 1/4, Unit = inch (mm)

① Motor/Gearhead

51K90GU-AWU
51K90GU-CWE
51K90GU-SW
51K90GU-AFUL

Weight (Mass): 7.1 lb.(3.2 kg)

5GU□KA

Weight (Mass): 3.3 lb.(1.5 kg)

51K90A-AWU
51K90A-CWE
51K90A-SW
51K90A-AFUL

Weight (Mass): 7.1 lb.(3.2 kg)

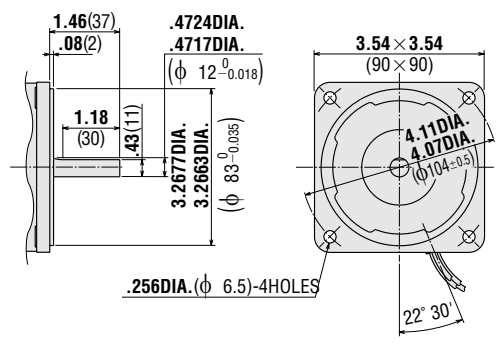
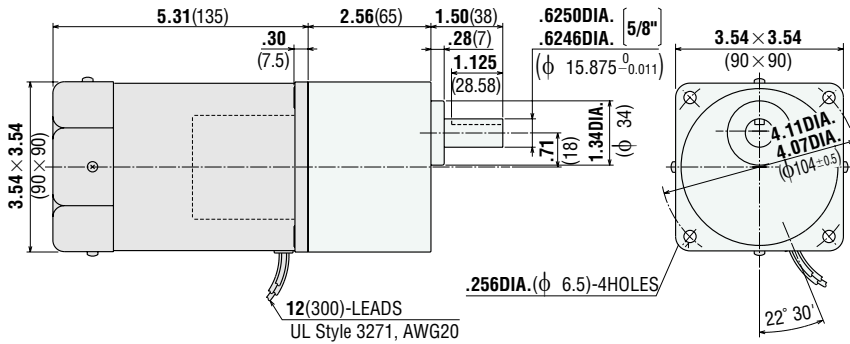

② Motor/Gearhead

51K90GU-AWTU
51K90GU-CWTE
51K90GU-SWT

Weight (Mass): 7.3 lb.(3.3 kg)

5GU□KA

Weight (Mass): 3.3 lb.(1.5 kg)

51K90A-AWTU
51K90A-CWTE
51K90A-SWT

Weight (Mass): 7.3 lb.(3.3 kg)

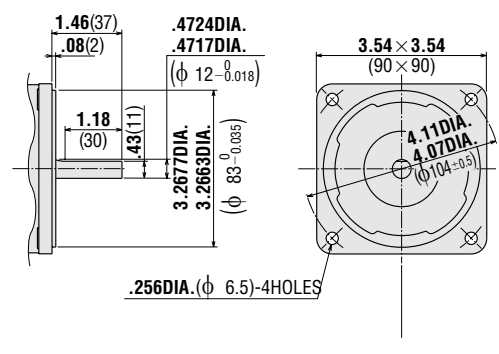
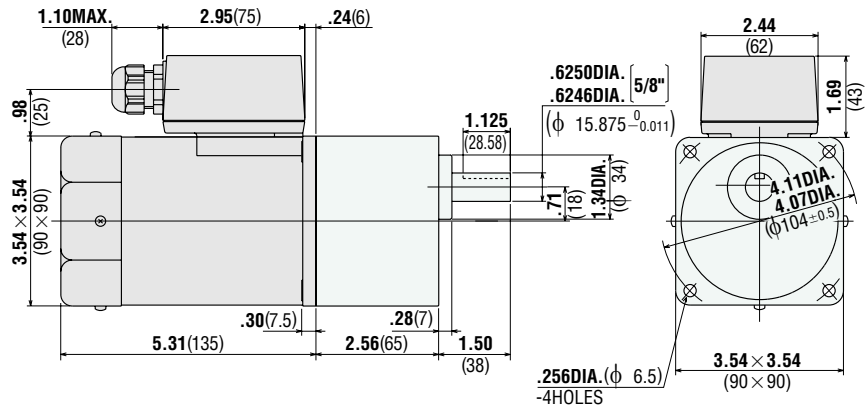

Use catbrye cable with the diameter of .24DIA.(φ 6)~.47DIA.(φ 12).

③ Motor/Gearhead

51K90GU-FCH
51K90GU-ECH

Weight (Mass): 8.2 lb.(3.7 kg)

5GU□KA

Weight (Mass): 3.3 lb.(1.5 kg)

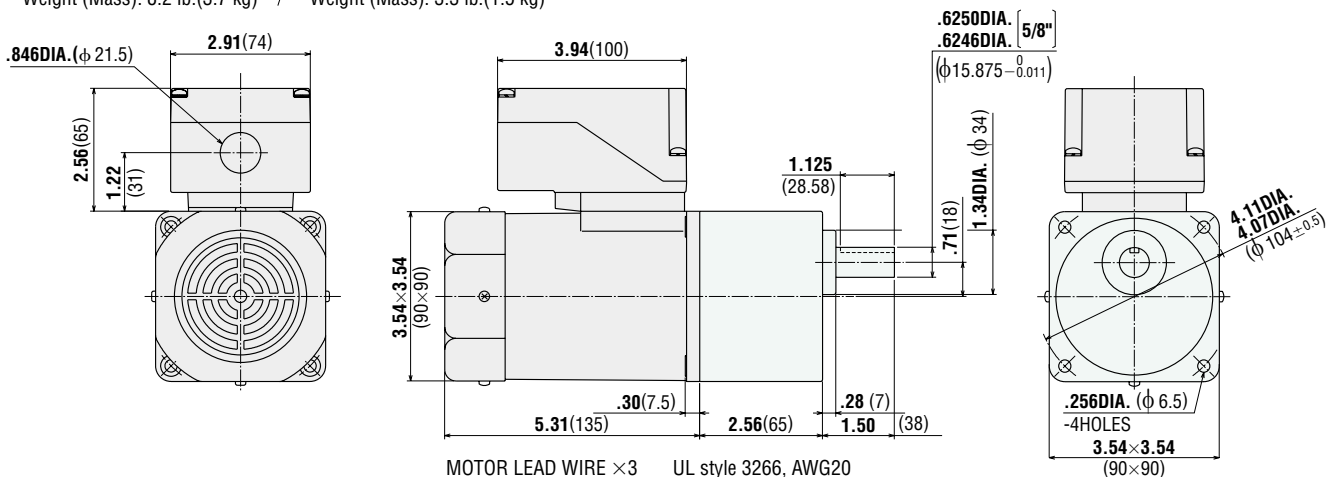

MOTOR LEAD WIRE ×3 UL style 3266, AWG20
 GROUND LEAD WIRE ×1 UL style 3266, AWG18

5IK90A-FCH
5IK90A-ECH

Weight (Mass): 8.2 lb.(3.7 kg)

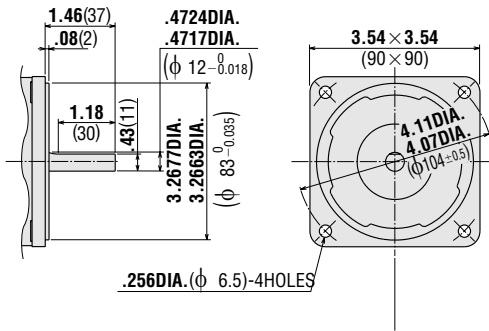

5IK90GU-SH

Weight (Mass): 7.3 lb.(3.3 kg)

5GU□KA

Weight (Mass): 3.3 lb.(1.5 kg)

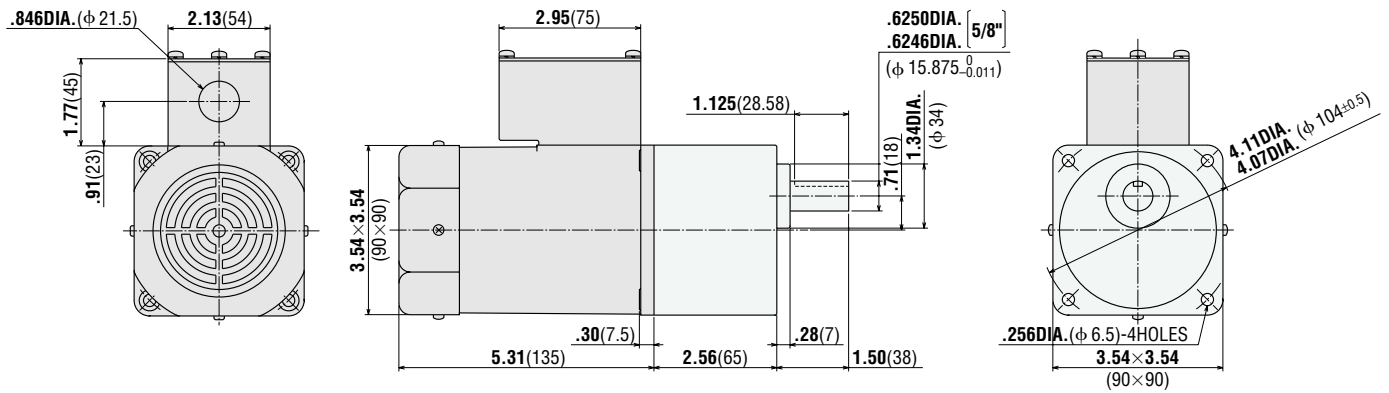

MOTOR LEAD WIRE $\times 3$ UL style 3266, AWG20
 GROUND LEAD WIRE $\times 1$ UL style 3266, AWG18

5IK90A-SH

Round Shaft Type

Weight (Mass): 7.3 lb.(3.3 kg)

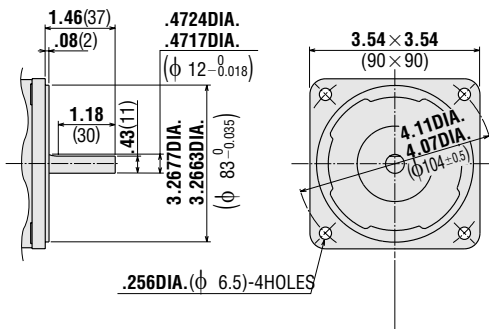

● Decimal Gearhead

5GU10XKB Weight (Mass): 1.32 lb.(0.6 kg)

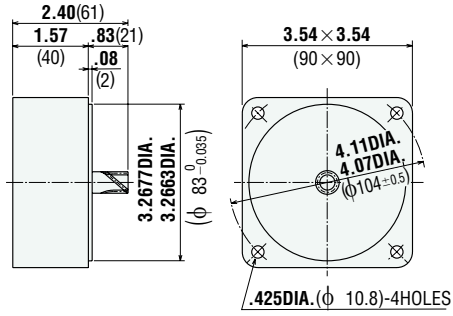

● **Key and Key Slot** Scale 1/2
(The key is provided with the gearhead)

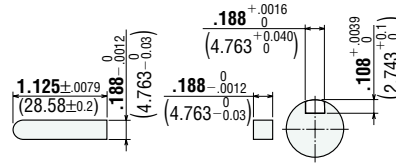

● Capacitor (included with the motor)

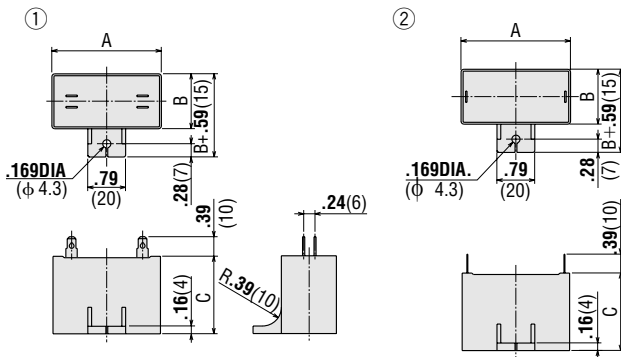

| Motor Model | Capacitor Model | Dimensions in. (mm) | | | Weight oz (g) | Dimension No. |
|---------------------|-----------------|---------------------|--------|------|---------------|---------------|
| | | A | B | C | | |
| 5IK90GU-AW□U | CH200CFAUL | 2.28 | 1.14 | 1.61 | 3.35 (95) | ① |
| 5IK90A-AW□U | | (58) | (29) | (41) | | |
| 5IK90GU-CW□E | CH60BFAUL | 2.28 | 1.14 | 1.61 | 3.00 (85) | ① |
| 5IK90A-CW□E | | (58) | (29) | (41) | | |
| 5IK90GU-AFUL | CH200UL | 2.28 | 0.91 | 1.46 | 2.29 (65) | ② |
| 5IK90A-AFUL | | (58) | (23.5) | (37) | | |

If you need to order a capacitor without a motor, add "-C" to the capacitor model number shown. A capacitor cap is always included with a capacitor.

■ Right-Angle Gearheads

The right-angle gearhead provides an output shaft that is at a right angle to the motor's output shaft. See page [A-216] for specifications and other information.



■ Wiring Diagrams

The direction of motor rotation is as viewed from the shaft end of the motor.

| Model Direction | Lead Wire Type | | |
|--------------------|--|--|---------------------|
| | 5IK90GU-AWU 5IK90GU-CWE | 5IK90GU-SW | 5IK90GU-AFUL |
| CW | | | |
| CCW | To rotate the motor in a clockwise (CW) direction, flip switch SW to CW. To rotate it in a counterclockwise (CCW) direction, flip switch SW to CCW. | To change the rotation, change any two connections between U, V and W. | |

| Model Direction | Terminal Box Type | | Conduit Box Type | |
|--------------------|--|--|--|--|
| | 5IK90GU-AWTU 5IK90GU-CWTE | 5IK90GU-SWT | 5IK90GU-FCH 5IK90GU-ECH | 5IK90GU-SH |
| CW | | | | |
| CCW | To rotate the motor in a clockwise (CW) direction, flip switch SW to CW. To rotate it in a counterclockwise (CCW) direction, flip switch SW to CCW. | To change the rotation, change any two connections between U, V and W. | To rotate the motor in a clockwise (CW) direction, flip switch SW to CW. To rotate it in a counterclockwise (CCW) direction, flip switch SW to CCW. | To change the rotation, change any two connections between U, V and W. |

Change the direction of motor rotation only after bringing the motor to a stop.

If an attempt is made to change the direction of rotation while the motor is rotating, the motor may ignore the reversing command or change its direction of rotation after some delay.

■ Accessories

● Motor Mounting Brackets

Optional die-cast aluminum mounting brackets are available. They can be used to install motors with or without gearheads. See page [A-266] for the dimensions.

Model name **SOL5UA**



● Flexible Coupling

Optional clamping couplings are available. See page [A-260] for the dimensions.



INDUCTION MOTORS BH Series

Single-Phase, Three-Phase

200w (1/3.73 HP)



Frame Size 4.09 in.sq.(104mm sq.)



- **BH Series motors provide 200W output power and up to 347 lb-in (40 N·m) of torque in a compact 4.09"sq. mounting configuration.**
- **For easy installation, the BH Series motor and gearhead come pre-assembled. Motors and gearheads are also available separately so you can have them on hand to make changes or repairs.**

■ Specifications — Continuous Rating

| Model | | Output Power | Voltage | Frequency | Current | Starting Torque | Rated Torque | Rated Speed | Capacitor | |
|--------------------------------------|--|------------------|---------|-----------|---------|-----------------|----------------|----------------|-----------|----|
| Upper Model Name:Pinion Shaft Type | Lower Model Name():Round Shaft Type | | | | | | | | | |
| Cable clamp Type Dimension ① | Terminal Box Type Dimension ② | HP | W | V | Hz | A | oz-in. mN·m | oz-in. mN·m | r/min. | μF |
| BHI62F-□ (BHI62F-A) | BHI62FT-□ (BHI62FT-A) | Single Phase 110 | | 60 | 3 | 125 | 900 | 181 1300 | 1500 | 40 |
| | | Single Phase 115 | | 60 | | 139 | 1000 | 181 1300 | 1500 | |
| — | BHI62ET-□ (BHI62ET-A) | Single Phase 220 | | 60 | 1.5 | 139 | 1000 | 181 1300 | 1500 | 10 |
| | | Single Phase 230 | | 50 | 1.5 | 139 | 1000 | 215 1550 | 1250 | |
| — | BHI62ST-□ (BHI62ST-A) | Single Phase 230 | | 60 | 1.5 | 139 | 1000 | 181 1300 | 1500 | — |
| | | Three Phase 200 | | 50 | 1.1 | 215 | 1550 | 215 1550 | 1250 | |
| | | Three Phase 200 | | 60 | 1.1 | 181 | 1300 | 181 1300 | 1500 | |
| | | Three Phase 220 | | 60 | 0.95 | 174 | 1250 | 174 1250 | 1550 | |
| Three Phase 230 | | 60 | 0.95 | 167 | 1200 | 167 1200 | 1600 | | | |

- The product contains a built-in thermal protector. When a motor overheats for any reason, the thermal protector is opened and the motor stops. When the motor temperature drops, the thermal protector closes and the motor restarts. Be sure to turn the motor off before inspecting.
- Enter the gear ratio in the box (□) within the model number.

■ Gearmotor — Torque Table

● Single-Phase 115V/230V 60Hz, Three-Phase 230V 60Hz

Unit = Upper values: lb-in / Lower values: N·m

| Model | Speed r/min | 500 | 300 | 200 | 120 | 100 | 60 | 50 | 30 | 20 | 15 | 10 |
|------------------|-------------|------------|----------|----------|-----------|-----------|-----------|-----------|-----------|-----------|------------|------------|
| | Gear Ratio | 3.6 | 6 | 9 | 15 | 18 | 30 | 36 | 60 | 90 | 120 | 180 |
| BHI62F-□ | 33 | 55 | 82 | 124 | 149 | 248 | 297 | 347 | 347 | 347 | 347 | 347 |
| | 3.8 | 6.3 | 9.5 | 14 | 17 | 28 | 34 | 40 | 40 | 40 | 40 | 40 |
| BHI62ET-□ | 3.0 | 51 | 76 | 114 | 137 | 229 | 274 | 347 | 347 | 347 | 347 | 347 |
| | 3.5 | 5.8 | 8.7 | 13 | 16 | 26 | 32 | 40 | 40 | 40 | 40 | 40 |

- Enter the gear ratio in the box within the model number.
- The speed is calculated by dividing the motor's synchronous speed (60Hz: 1800 r/min) by the gear ratio. The actual speed is 2 ~ 20% less than the displayed value, depending on the size of the load.

■ Dimensions Scale 1/4, Unit = inch (mm)

BHI62F-□

Weight (Mass): 18 lb.(8 kg)

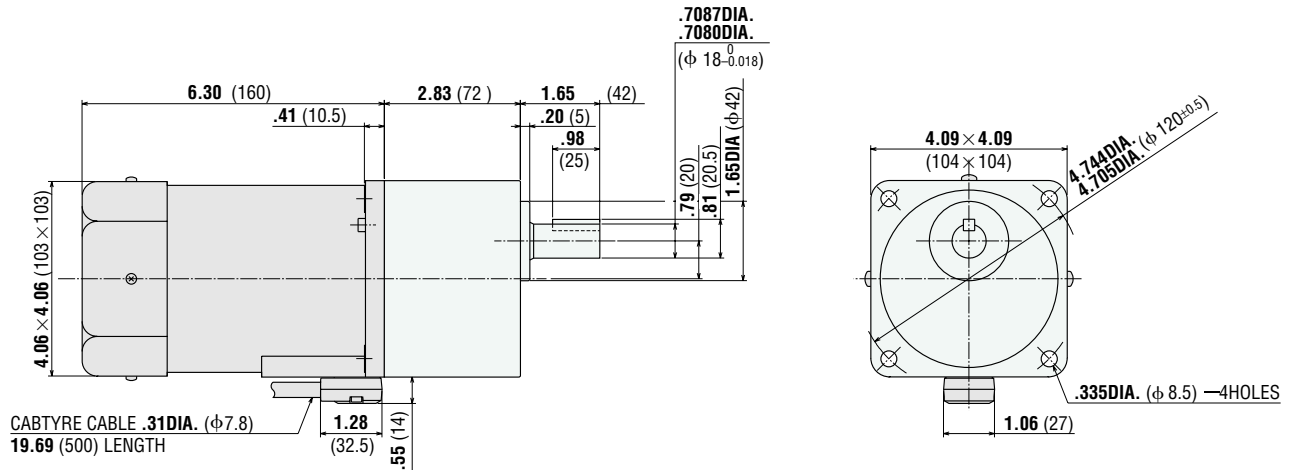

BHI62F-A

Weight (Mass): 11 lb.(5 kg)

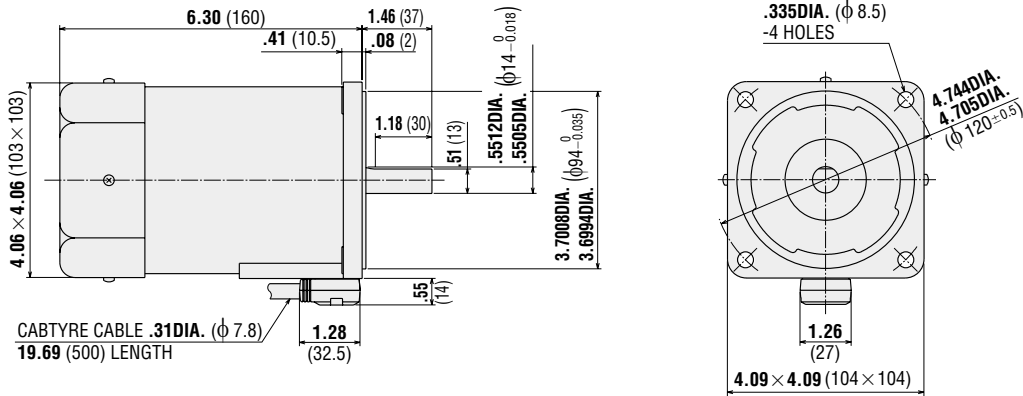

BHI62FT-□

BHI62ET-□

BHI62ST-□

Weight (Mass): 18 lb.(8 kg)

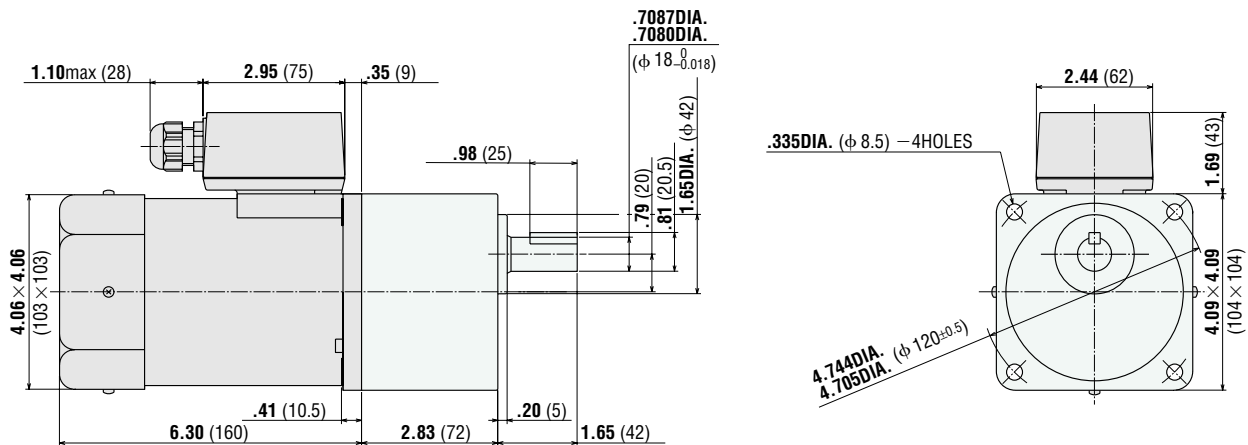

Use cabtyre cable with the diameter of
.24DIA. (φ 6) ~ **.47DIA.** (φ 12).

BHI62FT-A
BHI62ET-A
BHI62ST-A

Weight (Mass): 11 lb.(5kg)

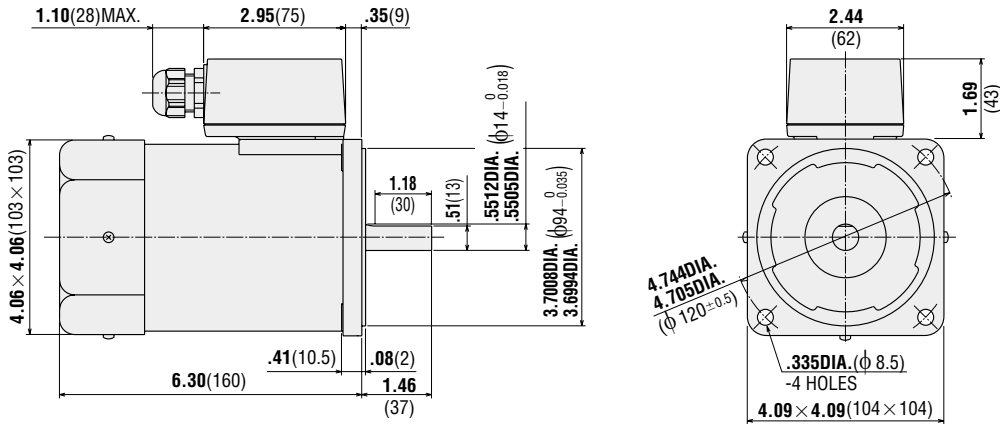

Use cabtyre cable with the diameter of .24DIA.(φ 6)~.47DIA.(φ 12).

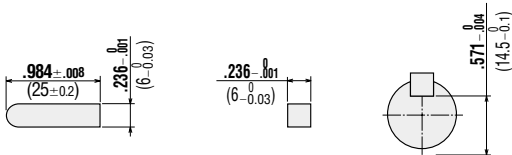

● **Capacitor** (included with the motor)

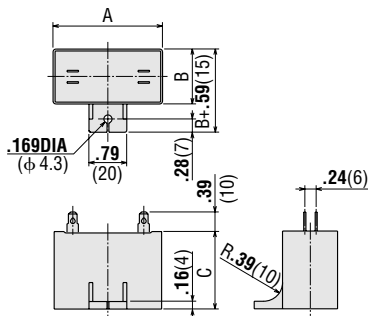

| Motor Model | Capacitor Model | Dimensions in. (mm) | | | Weight oz (g) |
|------------------|-----------------|---------------------|------|------|---------------|
| | | A | B | C | |
| BHI62F-□ | CH400CFAUL2 | 2.28 | 1.61 | 2.28 | 6.17 (175) |
| BHI62F-A | | (58) | (41) | (58) | |
| BHI62FT-□ | | | | | |
| BHI62FT-A | CH100BFAUL | 2.28 | 1.38 | 1.97 | 4.66 (132) |
| BHI62ET-□ | | (58) | (35) | (50) | |
| BHI62ET-A | | | | | |

Capacitor cap is provided with the capacitor.

■ Wiring Diagrams

The direction of motor rotation is as viewed from the shaft end of the motor.

| Model | Cable Clamp Type | | |
|-----------|--|--|--|
| | BHI62F-3.6~9 BHI62F-60~180 | BHI62F-15~36 | BHI62F-A |
| Direction | | | |
| CW | | | |
| CCW | To rotate the motor in a clockwise (CW) direction, flip switch SW to CW. To rotate it in a counterclockwise (CCW) direction, flip this switch to CCW. | To rotate the motor in a clockwise (CW) direction, flip switch SW to CW. To rotate it in a counterclockwise (CCW) direction, flip this switch to CCW. | To rotate the motor in a clockwise (CW) direction, flip switch SW to CW. To rotate it in a counterclockwise (CCW) direction, flip this switch to CCW. |

| Model | Terminal Box Type Single-Phase | | |
|-----------|--|--|--|
| | BHI62FT-3.6~9 BHI62ET-3.6~9 BHI62FT-60~180 BHI62ET-60~180 | BHI62FT-15~36 BHI62ET-15~36 | BHI62FT-A BHI62ET-A |
| Direction | | | |
| CW | | | |
| CCW | To rotate the motor in a clockwise (CW) direction, flip switch SW to CW. To rotate it in a counterclockwise (CCW) direction, flip this switch to CCW. | To rotate the motor in a clockwise (CW) direction, flip switch SW to CW. To rotate it in a counterclockwise (CCW) direction, flip this switch to CCW. | To rotate the motor in a clockwise (CW) direction, flip switch SW to CW. To rotate it in a counterclockwise (CCW) direction, flip this switch to CCW. |

| Model | Terminal Box Type Three-Phase | | |
|-----------|--|--|--|
| | BHI62ST-3.6~9 BHI62ST-60~180 | BHI62ST-15~36 | BHI62ST-A |
| Direction | | | |
| CW | | | |
| CCW | To change the rotation, change any two connections between U, V and W. | To change the rotation, change any two connections between U, V and W. | To change the rotation, change any two connections between U, V and W. |

Change the direction of motor rotation only after bringing the motor to a stop.

If an attempt is made to change the direction of rotation while the motor is rotating, the motor may ignore the reversing command or change its direction of rotation after some delay.

■ Accessories

● Motor Mounting Brackets

Optional die-cast aluminum mounting brackets are available. They can be used to install motors with or without gearheads. See page [A-266] for the dimensions.

Model name **SOL6M8**



● Flexible Coupling

Optional clamping couplings are available. See page [A-260] for the dimensions.



INDUCTION MOTORS 2-Pole, High Speed Type

Single-Phase

40W (1/18.5 HP) • 60W (1/12.5 HP) • 90W (1/8 HP)

Frame Size 3.15 in.sq.(80mm sq.), 3.54 in.sq.(90mm sq.)



■ Specifications — Continuous Rating

| Model | Output Power | | Voltage | Frequency | Current | Starting Torque | | Rated Torque | | Rated Speed | Capacitor |
|--------------------|--------------|----|---------|-----------|---------|-----------------|------|--------------|------|-------------|-----------|
| | HP | W | V AC | Hz | A | oz-in | mN·m | oz-in | mN·m | r/min | μF |
| 4IK40A-BA | 1/18.5 | 40 | 115 | 60 | 0.8 | 13.2 | 95 | 18 | 130 | 3000 | 8.0 |
| 5IK60A-BA | 1/12.5 | 60 | 115 | 60 | 1.2 | 16.7 | 120 | 25.7 | 185 | 3200 | 12.0 |
| 5IK90A-BFUL | 1/8 | 90 | 115 | 60 | 2.0 | 30.6 | 220 | 38.9 | 280 | 3200 | 20.0 |

• The product contains a built-in thermal protector. When a motor overheats for any reason, the thermal protector is opened and the motor stops. When the motor temperature drops, the thermal protector closes and the motor restarts. Be sure to turn the motor off before inspecting.

■ Wiring Diagrams

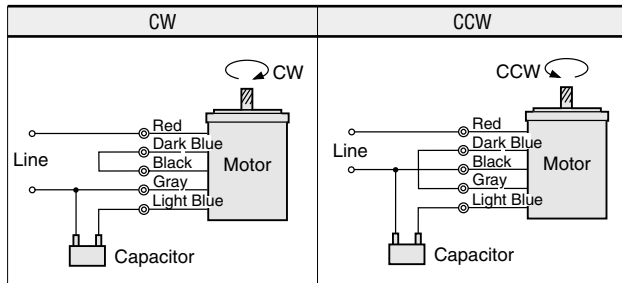

The direction of motor rotation is as viewed from the shaft end of the motor.

Change the direction of motor rotation only after bringing the motor to a stop. If an attempt is made to change the direction of rotation while the motor is rotating, the motor may ignore the reversing command or change its direction of rotation after some delay.

■ Dimensions Scale 1/4, Unit = inch (mm)

4IK40A-BA Weight (Mass): 3.3 lb.(1.5 kg)

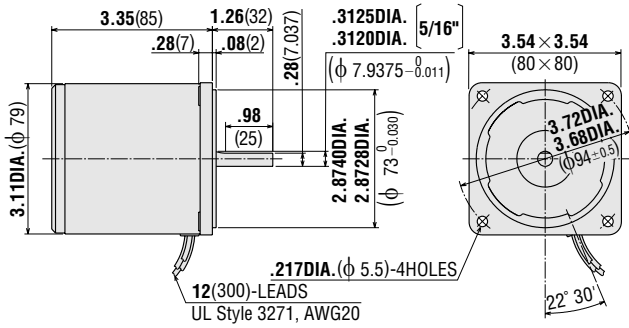

5IK60A-BA Weight (Mass): 5.5 lb.(2.5 kg)

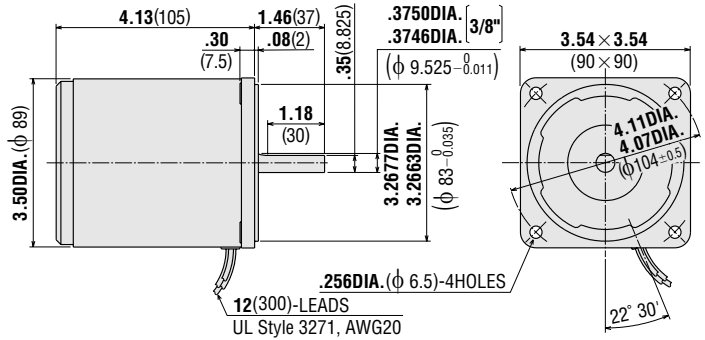

5IK90A-BFUL Weight (Mass): 6.0 lb.(2.7 kg)

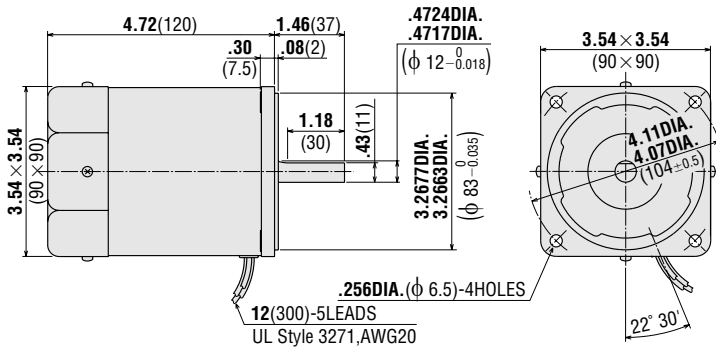

● Capacitor (included with the motor)

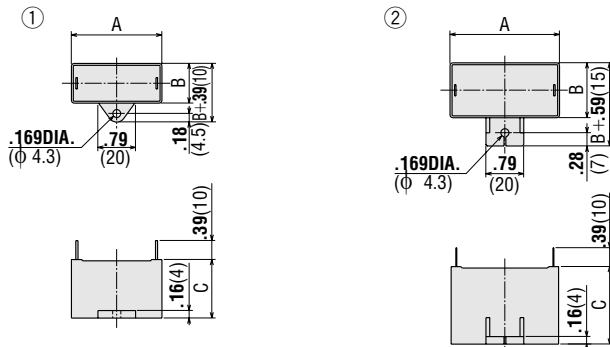

| Motor Model | Capacitor Model | Dimensions inch (mm) | | | Weight oz (g) | Dimensions Number |
|--------------------|-----------------|----------------------|------|------|---------------|-------------------|
| | | A | B | C | | |
| 4IK40A-BA | CH80UL | 1.50 | .83 | 1.22 | 1.2 (35) | ① |
| | | (38) | (21) | (31) | | |
| 5IK60A-BA | CH120UL | 1.89 | .83 | 1.22 | 1.6 (44) | ① |
| | | (48) | (21) | (31) | | |
| 5IK90A-BFUL | CH200UL | 2.28 | .91 | 1.46 | 2.3 (65) | ② |
| | | (58) | (23) | (37) | | |

Capacitor cap is provided with the capacitor.

Features of Reversible Motors

Reversible motors are capacitor-run induction motors. By simple switching, the direction of motor rotation can be reversed instantly. These motors are very suitable for applications that require frequent switching between clockwise and counterclockwise rotation thus the name "Reversible Motor". While basically the same as the induction motors described, they feature a high starting torque to improve previously instantaneous reversing characteristics and use a simple built-in friction brake to reduce motor overrun and shorten the time required for reversing. These motors are designed for applications where instantaneous reversal of direction is required. However, due to their inherently higher temperature rise compared to induction motors, they have a limited 30-minute duty cycle rating for worst case operating conditions. A 30-minute rating means that the motor may be operated continuously for 30 minutes without an excessive rise in motor temperature. In other respects, such as speed-torque, voltage and capacitor characteristics, reversible motors are similar to an induction motor.

● Why do they have a Permanent Brake?

The brake mechanism provided on reversible motors consists of a teflon brake shoe that permanently applies friction to a brake plate by means of a coil spring. This means that in addition to the actual load, the motor must also overcome the friction load caused by the brake. The inevitable side effect of heat generation (which is the cause of the 30-minute duty rating of reversible motors) is outweighed by the following advantages of the brake:

1. It reduces overrun
2. It provides a degree of holding torque
3. It shortens the time necessary for switching from clockwise to counterclockwise rotation.

With these motors, the limited braking force provided by the motor design equals approximately one-tenth of the torque output. Table 1 shows typical holding torque and overrun values which vary slightly with different models. The values also vary with operating time and temperature and should, therefore, be used as a guide only.

Note that values shown for rated torque and starting torque of reversible motors are reference data measured for operation without the brake applied. Above described deviations from the theoretical figures should be taken into account when selecting a motor.

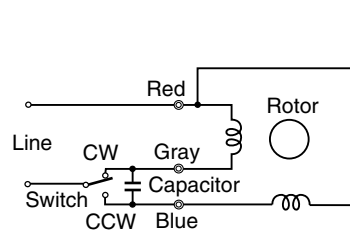
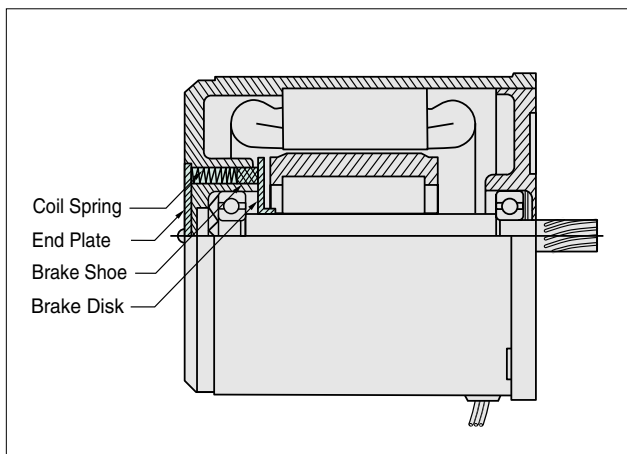

Wiring Diagram (CW direction)

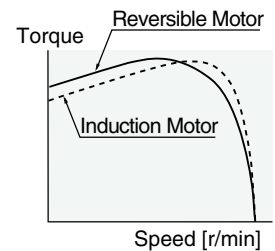

Speed-Torque Characteristic

Table 1. Holding Torque and Overrun in Reversible Motors (Reference Values)

| Motor Model | Holding Torque | | Overrun (revolution) |
|-----------------------|----------------|--------|-------------------------|
| | oz-in | mN · m | |
| ORK1GN-AUL | 0.14 | 1 | 3 |
| 2RJ4GB-AUL | 0.42 | 3 | 5 |
| 2RK6GN-AW(T)U | 0.69 | 5 | 4 |
| 2RK6GN-CW(T)E | | | |
| 2RK6GN-AUL | 0.69 | 5 | 4 |
| 3RK15GN-AWU | 1.8 | 13 | 5 |
| 3RK15GN-CWE | | | |
| 3RK15GN-AUL | 1.8 | 13 | 5 |
| 4RJ20GB-AUL | 1.9 | 14 | 6 |
| 4RK25GN-AW(T)U | 2.1 | 15 | 5 |
| 4RK25GN-CW(T)E | | | |
| 4RK25GN-AUL | 2.1 | 15 | 5 |
| 5RK40GN-AW(T)U | 5.6 | 40 | 6 |
| 5RK40GN-CW(T)E | | | |
| 5RK40GN-AUL | 5.6 | 40 | 6 |
| 5RK60GU-AW(T)U | 5.6 | 40 | 6 |
| 5RK60GU-CW(T)E | | | |
| 5RK60GU-AFUL | 5.6 | 40 | 6 |
| 5RK90GU-AW(T)U | 5.6 | 40 | 6 |
| 5RK90GU-CW(T)E | | | |
| 5RK90GU-AFUL | 5.6 | 40 | 6 |

● Holding torque may be less than the value given in the table when first used.

Product Specifications

■ Reversible Motors

| Output Power | | Model | | Voltage | Frequency | Starting Torque | | Rated Torque | | Rated Speed | Page | |
|--------------|---------------------|---------------------|---------------------|---------------------|------------------|-----------------|-------|--------------|-------|-------------|-------|------|
| HP | W | Lead | Wire Type | Terminal Box Type | V AC | Hz | oz-in | mN·m | oz-in | mN·m | r/min | |
| 1/746 | 1 | | 0RK1GN-AUL | — | Single-Phase 115 | 60 | 1.1 | 8 | 1.1 | 8 | 1200 | A-78 |
| 1/186 | 4 | | 2RJ4GB-AUL | — | Single-Phase 115 | 60 | 3.5 | 25 | 3.7 | 27 | 1450 | A-80 |
| 1/124 | 6 | | 2RK6GN-AWU | 2RK6GN-AWTU | Single-Phase 110 | 60 | 6.2 | 45 | 5.7 | 41 | 1450 | A-82 |
| | | | | | Single-Phase 115 | 60 | | | | | | |
| | | | | | Single-Phase 220 | 60 | 6.2 | 45 | 5.7 | 41 | 1450 | |
| | | | 2RK6GN-CWE | 2RK6GN-CWTE | Single-Phase 230 | 50 | 6.9 | 50 | 6.8 | 49 | 1200 | A-82 |
| | | | | | Single-Phase 230 | 60 | 6.2 | 45 | 5.7 | 41 | 1450 | |
| 1/50 | 15 | | 2RK6GN-AUL | — | Single-Phase 115 | 60 | 5.1 | 37 | 5.6 | 40 | 1500 | A-82 |
| | | | 3RK15GN-AWU | — | Single-Phase 110 | 60 | 13.9 | 100 | 14.6 | 105 | 1450 | A-85 |
| | | | | | Single-Phase 115 | 60 | | | | | | |
| | | | 3RK15GN-CWE | — | Single-Phase 220 | 60 | 13.9 | 100 | 14.6 | 105 | 1450 | |
| | | | | | Single-Phase 230 | 50 | 13.9 | 100 | 17.4 | 125 | 1200 | A-85 |
| 1/37 | 20 | | | | Single-Phase 230 | 60 | 13.9 | 100 | 14.6 | 105 | 1450 | |
| | | | 3RK15GN-AUL | — | Single-Phase 115 | 60 | 10.4 | 75 | 13.9 | 100 | 1500 | A-85 |
| | | | 4RJ20GB-AUL | — | Single-Phase 115 | 60 | 14.6 | 105 | 18.7 | 135 | 1500 | A-88 |
| 1/30 | 25 | | 4RK25GN-AWU | 4RK25GN-AWTU | Single-Phase 110 | 60 | 19.4 | 140 | 23.6 | 170 | 1450 | A-90 |
| | | | | | Single-Phase 115 | 60 | | | | | | |
| | | | 4RK25GN-CWE | 4RK25GN-CWTE | Single-Phase 220 | 60 | 19.4 | 140 | 23.6 | 170 | 1450 | |
| | | | | | Single-Phase 230 | 50 | 22.2 | 160 | 28.5 | 205 | 1200 | A-90 |
| 1/27.5 | 27 | | | | Single-Phase 230 | 60 | 19.4 | 140 | 23.6 | 170 | 1450 | |
| | | | 4RK25GN-AUL | — | Single-Phase 115 | 60 | 16.0 | 115 | 23.6 | 170 | 1550 | A-90 |
| 1/18.5 | 40 | | 5RK40GN-AWU | 5RK40GN-AWTU | Single-Phase 110 | 60 | 36.1 | 260 | 37.5 | 270 | 1450 | A-93 |
| | | | | | Single-Phase 115 | 60 | | | | | | |
| | | | | | Single-Phase 220 | 60 | 36.1 | 260 | 36.1 | 260 | 1500 | |
| | | | 5RK40GN-CWE | 5RK40GN-CWTE | Single-Phase 230 | 50 | 37.5 | 270 | 43.7 | 315 | 1250 | A-93 |
| | | | | | Single-Phase 230 | 60 | 36.1 | 260 | 36.1 | 260 | 1500 | |
| 1/12.5 | 60 | | 5RK40GN-AUL | — | Single-Phase 115 | 60 | 36.1 | 260 | 36.1 | 260 | 1550 | A-93 |
| | | | 5RK60GU-AWU | 5RK60GU-AWTU | Single-Phase 110 | 60 | 52.8 | 380 | 56.2 | 405 | 1450 | A-96 |
| | | | | | Single-Phase 115 | 60 | | | | | | |
| | | | 5RK60GU-CWE | 5RK60GU-CWTE | Single-Phase 220 | 60 | 52.8 | 380 | 56.2 | 405 | 1450 | |
| | | | | | Single-Phase 230 | 50 | 65.3 | 470 | 68.0 | 490 | 1200 | A-96 |
| 1/8 | 90 | | | | Single-Phase 230 | 60 | 52.8 | 380 | 56.2 | 405 | 1450 | |
| | | | 5RK60GU-AFUL | — | Single-Phase 115 | 60 | 51.4 | 370 | 51.4 | 370 | 1600 | A-96 |
| | | | 5RK90GU-AWU | 5RK90GU-AWTU | Single-Phase 110 | 60 | 81.9 | 590 | 81.2 | 585 | 1500 | A-99 |
| | | | Single-Phase 115 | 60 | | | | | | | | |
| | | | Single-Phase 220 | 60 | 81.9 | 590 | 84.0 | 605 | 1450 | | | |
| | 5RK90GU-CWE | 5RK90GU-CWTE | Single-Phase 230 | 50 | 83.3 | 600 | 101 | 730 | 1200 | A-99 | | |
| | | | Single-Phase 230 | 60 | 81.9 | 590 | 84.0 | 605 | 1450 | | | |
| | 5RK90GU-AFUL | — | Single-Phase 115 | 60 | 81.9 | 590 | 79.2 | 570 | 1550 | A-99 | | |

- Products in this table have pinion shafts. Round shaft types are available for all models(excluding **5RK60GU-AFUL**, **5RK90GU-AFUL**). See the appropriate product pages for more information.
- The "U" and "E" at the end of the model name indicate that the unit includes a capacitor. These two letters are not listed on the motor nameplate. When the motor is approved under various safety standards, the nameplate is adopted.

■ General Specifications

For **-AW(T)U, -CW(T)E**

| Item | Specifications |
|---------------------------|---|
| Insulation Resistance | 100M Ω or more when 500V DC is applied between the windings and the frame. |
| Dielectric Strength | Sufficient to withstand 1.5kV at 50Hz and 60Hz applied between the windings and the frame. |
| Temperature Rise | 144°F (80°C) or less measured by the resistance change method after rated motor operation with connecting a gearhead or equivalent heat radiation plate. |
| Insulation Class | Class B (266°F [130°C]) |
| Overheat Protection | 2RK have impedance protection. All others have a built-in thermal protector (Automatic return type) Operating temperature, open : 266°F±9°F (130°C±5°C) close: 179.6°F±27°F (82°C±15°C) |
| Ambient Temperature Range | 14°F~104°F (-10°C~+40°C) |
| Ambient Humidity | 85% maximum (noncondensing) |

Equivalent heat radiation plate (material: Aluminum)

| Type (output) | Size inch (mm) | Thickness inch (mm) |
|-------------------------|---------------------|---------------------|
| 2RK Type (6W) | 4.53×4.53 (115×115) | 0.20 (5) |
| 3RK Type (15W) | 4.92×4.92 (125×125) | |
| 4RK Type (25W) | 5.31×5.31 (135×135) | |
| 5RK40 Type (40W) | 6.50×6.50 (165×165) | |
| 5RK60 Type (60W) | 7.87×7.87 (200×200) | |
| 5RK90 Type (90W) | 7.87×7.87 (200×200) | |

For **-AUL, -AULA, -AFUL**

| Item | Specifications |
|---------------------------|--|
| Insulation Resistance | 100M Ω or more Insulation Resistance when 500V DC is applied between the windings and frame after the rated motor operation under normal ambient temperature and humidity. |
| Dielectric Strength | Sufficient to withstand 1.5kV at 50Hz and 60Hz applied between the windings and the frame after rated motor operation under normal ambient temperature and humidity. |
| Temperature Rise | 135°F (75°C) or less measured by the resistance change method after the temperature of the coil has stabilized under normal operation at the rated voltage and frequency. |
| Insulation Class | UL, CSA Standard Class A EN60950 Standard Class E |
| Overheat Protection | ORK and 2RK have impedance protection. All others have a built-in thermal protector. (Automatic return type) Operating temperature, open: 248°F±9°F (120°C±5°C) close: 170.6°F±27°F (77°C±15°C) |
| Ambient Temperature Range | 14°F ~ 104°F (-10°C ~ +40°C) |
| Ambient Humidity | 85% maximum (noncondensing) |

■ Safety Standards and CE Marking

For **-AW(T)U, -CW(T)E**

| Standards | Certification Body | Standards File No. | CE Marking |
|--|---|-----------------------------------|-----------------------|
| UL1004 UL519 (6W Type) UL547 (15W~90W Type) CAN/CSA C22.2 No.100 CAN/CSA C22.2 No.77 | UL | E64199 (6W) E64197 (15W~90W) | Low Voltage Directive |
| EN60950 | VDE | 114919ÜG (6W) 6751ÜG (15W~90W) | |
| EN60034-1 EN60034-5 IEC60034-11 | Conform to EN/IEC Standards (EN/IEC certifications are scheduled.) | | |

* Excluding terminal box types

For installation for EN/IEC standards, see Page D-2.

Recognized name and certified name of each safety standards are motor model name.

For **-AUL, -AULA** and **-AFUL** Type

| Standards | Certification Body | Standards File No. | CE Marking |
|---|--------------------|------------------------------------|-----------------------|
| UL1004 UL519 (6W Type) UL547 (15W~90W Type) | UL | E64199 (1W~6W) E64197 (15W~90W) | Low Voltage Directive |
| CAN/CSA C22.2 No.100 CAN/CSA C22.2 No.77 | CSA | LR47296 | |
| EN60950 | VDE | 5876ÜG (1W~6W) 5877ÜG (15W~90W) | |

For installation for EN/IEC standards, see Page D-2.

REVERSIBLE MOTORS

Single-Phase

1W (1/746 HP)

Frame Size 1.65 in.sq. (42mm sq.)



Specifications — 30 Minutes Rating

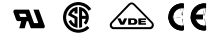

| Model | | Output Power | | Voltage | Frequency | Current | Starting Torque | | Rated Torque | | Rated Speed | Capacitor |
|-------------------|------------------|--------------|---|---------|-----------|---------|-----------------|------|--------------|------|-------------|-----------|
| Pinion Shaft Type | Round Shaft Type | HP | W | V AC | Hz | A | oz-in | mN·m | oz-in | mN·m | r/min | μF |
| ORK1GN-AUL | ORK1A-AUL | 1/746 | 1 | 115 | 60 | 0.10 | 1.1 | 8 | 1.1 | 8 | 1200 | 1.2 |

- Values shown for starting torque and rated torque are measured for operation without the brake applied.
- These products are impedance protected.

Gearmotor — Torque Table

Unit = Upper values: lb-in / Lower values: N·m

| Model | Speed r/min | 600 | 500 | 360 | 300 | 240 | 200 | 144 | 120 | 100 | 72 | 60 | 50 | 36 | 30 | 24 | 20 | 18 | 15 | 12 | 10 |
|----------------------------|-------------|-------|-------|-------|-------|-------|-------|-------|-------|------|------|------|------|------|------|------|------|------|------|------|------|
| | Gear Ratio | 3 | 3.6 | 5 | 6 | 7.5 | 9 | 12.5 | 15 | 18 | 25 | 30 | 36 | 50 | 60 | 75 | 90 | 100 | 120 | 150 | 180 |
| ORK1GN-AUL / OGN□KA | | 0.17 | 0.20 | 0.28 | 0.33 | 0.42 | 0.50 | 0.63 | 0.75 | 0.90 | 1.1 | 1.4 | 1.6 | 2.3 | 2.7 | 3.0 | 3.7 | 4.1 | 4.9 | 6.1 | 7.3 |
| | | 0.019 | 0.023 | 0.032 | 0.039 | 0.049 | 0.058 | 0.073 | 0.088 | 0.11 | 0.13 | 0.16 | 0.19 | 0.26 | 0.32 | 0.35 | 0.42 | 0.47 | 0.57 | 0.71 | 0.85 |

- Gearheads are sold separately. Decimal gearheads are not available for OGN type.
- Enter the gear ratio in the box (□) within the model number. A colored background indicates gear shaft rotation in the same direction as the motor shaft; a white background indicates rotation in the opposite direction.
- The speed is calculated by dividing the motor's synchronous speed (60 Hz: 1800 r/min) by the gear ratio. The actual speed is 2 ~ 20% less than the displayed value, depending on the size of the load.

Wiring Diagram

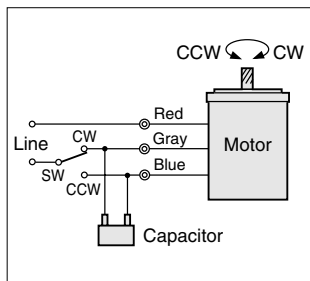

To rotate the motor in a clockwise (CW) direction, flip switch SW to CW.
To rotate it in a counterclockwise (CCW) direction, flip switch SW to CCW.

The direction of motor rotation is as viewed from the shaft end of the motor.

■ Dimensions Scale 1/4, Unit = inch (mm)

ORK1GN-AUL / **OGNKA**
 Weight (Mass): 0.7 lb.(0.3 kg) Weight(Mass): 0.44 lb.(0.2 kg)

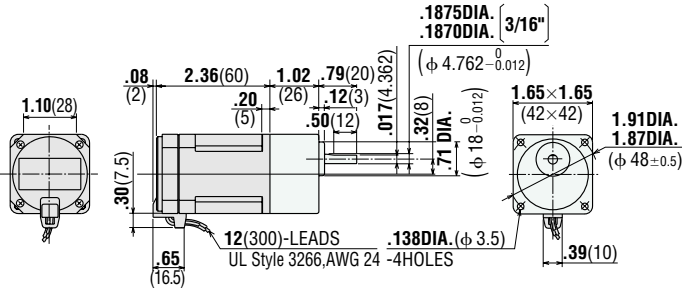

ORK1A-AUL Round Shaft Type
 Weight (Mass): 0.7 lb.(0.3 kg)

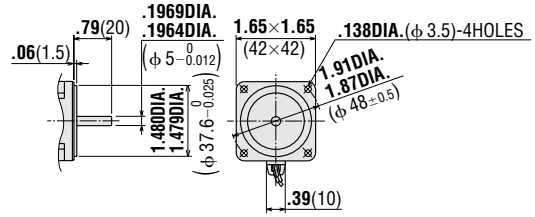

● Capacitor (included with the motor)

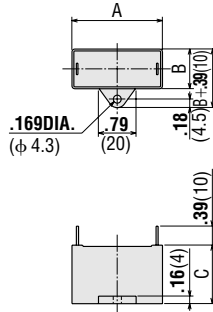

| Motor Model | Capacitor Model | Dimensions inch (mm) | | | Weight (Mass) oz (g) |
|-------------------|-----------------|----------------------|--------|--------|----------------------|
| | | A | B | C | |
| ORK1GN-AUL | CH12UL | 1.22 | 0.57 | 0.93 | 0.6 (17) |
| ORK1A-AUL | | (31) | (14.5) | (23.5) | |

If you need to order a capacitor without a motor, add "-C" to the capacitor model number shown. A capacitor cap is always included with a capacitor.

■ Accessories

● Motor Mounting Brackets

Optional die-cast aluminum mounting brackets are available. They can be used to install motors without gearheads. See page [A-266] for the dimensions. Model name **SOLOU04**



● Flexible Couplings

Optional clamping couplings are available. See page[A-260] for the dimensions.



REVERSIBLE MOTORS

Single-Phase

4W (1/186 HP)

Frame Size 2.36 in.sq. (60mm sq.)



■ Specifications — 30 Minutes Rating

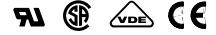

| Model | | Output Power | | Voltage | Frequency | Current | Starting Torque | | Rated Torque | | Rated Speed | Capacitor |
|-------------------|-------------------|--------------|---|---------|-----------|---------|-----------------|------|--------------|------|-------------|-----------|
| Pinion Shaft Type | Round Shaft Type | HP | W | V AC | Hz | A | oz-in | mN·m | oz-in | mN·m | r/min | μF |
| 2RJ4GB-AUL | 2RJ4A-AULA | 1/186 | 4 | 115 | 60 | 0.17 | 3.5 | 25 | 3.7 | 27 | 1450 | 1.8 |

- Values shown for starting torque and rated torque are measured for operation without the brake applied.
- These products are impedance protected.

■ Gearmotor — Torque Table

The permissible torque with decimal gearhead with a gear ratio of 10:1 is 13 lb-in (1.5N·m).

Unit = Upper values: lb-in / Lower values: N·m

| Model | Speed r/min | 600 | 500 | 360 | 300 | 240 | 200 | 144 | 120 | 100 | 72 | 60 | 50 | 36 | 30 | 24 | 20 | 18 | 15 | 12 | 10 | 7.2 | 6 | 5 |
|----------------------------|-------------|-------|-------|------|------|------|------|------|------|------|------|------|------|------|-----|-----|-----|-----|-----|-----|-----|-----|-----|-----|
| | Gear Ratio | 3 | 3.6 | 5 | 6 | 7.5 | 9 | 12.5 | 15 | 18 | 25 | 30 | 36 | 50 | 60 | 75 | 90 | 100 | 120 | 150 | 180 | 250 | 300 | 360 |
| 2RJ4GB-AUL / 2GB□KA | | 0.56 | 0.67 | 0.94 | 1.1 | 1.4 | 1.7 | 2.3 | 2.8 | 3.4 | 4.2 | 5.1 | 6.1 | 7.6 | 9.2 | 11 | 13 | 13 | 13 | 13 | 13 | 13 | 13 | 13 |
| | | 0.066 | 0.079 | 0.11 | 0.13 | 0.16 | 0.20 | 0.27 | 0.33 | 0.39 | 0.49 | 0.59 | 0.71 | 0.89 | 1.1 | 1.3 | 1.5 | 1.5 | 1.5 | 1.5 | 1.5 | 1.5 | 1.5 | 1.5 |

- Gearheads are sold separately.
- Enter the gear ratio in the box (□) within the model number. A colored background indicates gear shaft rotation in the same direction as the motor shaft; a white background indicates rotation in the opposite direction.
- The speed is calculated by dividing the motor's synchronous speed (60 Hz: 1800 r/min) by the gear ratio. The actual speed is 2 ~ 20% less than the displayed value, depending on the size of the load.

■ Wiring Diagram

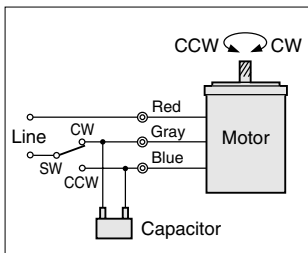

To rotate the motor in a clockwise (CW) direction, flip switch SW to CW.
To rotate it in a counterclockwise (CCW) direction, flip switch SW to CCW.

The direction of motor rotation is as viewed from the shaft end of the motor.

■ Dimensions Scale 1/4, Unit = inch (mm)

2RJ4GB-AUL

Weight (Mass): 1.3 lb.(0.6 kg)

/ 2GB□KA

Weight (Mass): 0.66 lb.(0.3 kg)

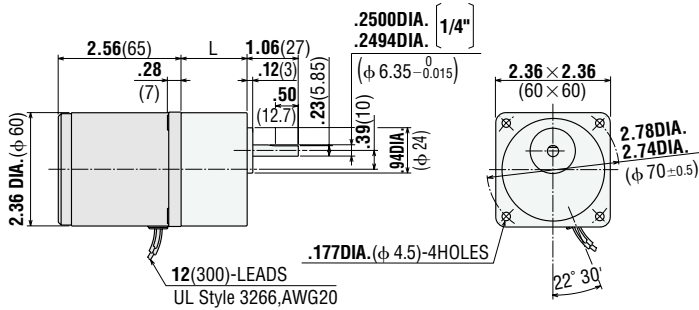

L = 1.02(26) **2GB3KA ~ 18KA**
L = 1.38(35) **2GB25KA ~ 360KA**

2RJ4A-AULA Round Shaft Type

Weight (Mass): 1.3 lb.(0.6 kg)

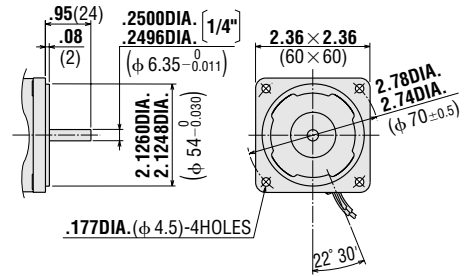

● Decimal Gearhead

2GB10XK Weight (Mass): 0.44 lb.(0.2 kg)

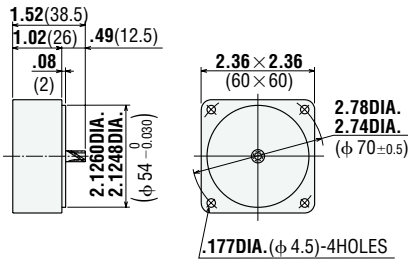

● Capacitor (included with the motor)

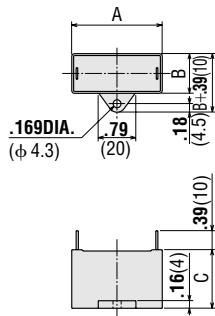

| Motor Model | Capacitor Model | Dimensions inch (mm) | | | Weight (Mass) oz (g) |
|-------------|-----------------|----------------------|------|------|----------------------|
| | | A | B | C | |
| 2RJ4GB-AUL | CH18BUL | 1.46 | 0.67 | 1.06 | 0.7 (20) |
| 2RJ4A-AULA | | (37) | (18) | (27) | |

If you need to order a capacitor without a motor, add "-C" to the capacitor model number shown. A capacitor cap is always included with a capacitor.

■ Accessories

● Motor Mounting Brackets

Optional die-cast aluminum mounting brackets are available. They can be used to install motors without gearheads. See page [A-266] for the dimensions.

Model name **SOL2U8**



● Flexible Couplings

Optional clamping couplings are available. See page[A-260] for the dimensions.



REVERSIBLE MOTORS

Single-Phase

6W (1/124 HP)

Frame Size 2.36 in.sq. (60mm sq.)



Specifications — 30 Minutes Rating



| Model | | Output Power | Voltage | Frequency | Current | Starting Torque | | Rated Torque | | Rated Speed | Capacitor | | |
|--|-------------------------------|--------------|---------|-----------|---------|----------------------------------|-----|--------------|------|-------------|-----------|-----|---|
| Upper Model Name: Pinion Shaft Type Lower Model Name(): Round Shaft Type | Lead Wire Type Dimension ① | | | | | Terminal Box Type Dimension ② | HP | W | V AC | | | Hz | A |
| 2RK6GN-AWU 2RK6GN-AWTU (2RK6A-AWU) (2RK6A-AWTU) | | 1/124 | 6 | 110 | 60 | 0.25 | 6.2 | 45 | 5.7 | 41 | 1450 | 3.5 | |
| | | | | 115 | 60 | 0.26 | | | | | | | |
| | | | | 220 | 60 | 0.11 | 6.2 | 45 | 5.7 | 41 | 1450 | | |
| | | | | 230 | 50 | 0.12 | 6.9 | 50 | 6.8 | 49 | 1200 | | |
| 2RK6GN-CWE 2RK6GN-CWTE (2RK6A-CWE) (2RK6A-CWTE) | | | | 230 | 60 | 0.12 | 6.2 | 45 | 5.7 | 41 | 1450 | 0.8 | |
| | | | | | | | | | | | | | |
| 2RK6GN-AUL (2RK6A-AULA) | — | | | 115 | 60 | 0.19 | 5.1 | 37 | 5.6 | 40 | 1500 | 2.3 | |
| | | | | | | | | | | | | | |

- Values shown for starting torque and rated torque are measured for operation without the brake applied.
- These products are impedance protected.
- The "U" and "E" at the end of the model name indicate that the unit includes a capacitor. These two letters are not listed on the motor nameplate. When the motor is approved under various safety standards, the nameplate is adopted.
- The terminal box type of the motors are not VDE approved.

Gearmotor — Torque Table

The permissible torque with a decimal gearhead with a gear ratio of 10:1 is 26 lb-in (3N·m).

Single-Phase 115V/230V 60Hz

Unit = Upper values: lb-in / Lower values: N·m

| Model | Speed r/min Gear Ratio | 600 | 500 | 360 | 300 | 240 | 200 | 144 | 120 | 100 | 72 | 60 | 50 | 36 | 30 | 24 | 20 | 18 | 15 | 12 | 10 |
|--|---------------------------|----------|------------|----------|----------|------------|----------|-------------|-----------|-----------|-----------|-----------|-----------|-----------|-----------|-----------|-----------|------------|------------|------------|------------|
| | | 3 | 3.6 | 5 | 6 | 7.5 | 9 | 12.5 | 15 | 18 | 25 | 30 | 36 | 50 | 60 | 75 | 90 | 100 | 120 | 150 | 180 |
| 2RK6GN-AW(T)U / 2GN□KA 2RK6GN-CW(T)E / 2GN□KA | 0.87 | 1.0 | 1.4 | 1.7 | 2.2 | 2.6 | 3.6 | 4.3 | 5.2 | 6.5 | 7.8 | 9.4 | 12 | 14 | 18 | 21 | 24 | 26 | 26 | 26 | |
| | 0.10 | 0.12 | 0.17 | 0.20 | 0.25 | 0.30 | 0.42 | 0.50 | 0.60 | 0.75 | 0.90 | 1.1 | 1.4 | 1.6 | 2.0 | 2.4 | 2.7 | 3 | 3 | 3 | |
| 2RK6GN-AUL / 2GN□KA | 0.85 | 1.0 | 1.4 | 1.7 | 2.1 | 2.6 | 3.5 | 4.3 | 5.1 | 6.4 | 7.7 | 9.2 | 12 | 14 | 17 | 21 | 23 | 26 | 26 | 26 | |
| | 0.097 | 0.12 | 0.16 | 0.19 | 0.24 | 0.29 | 0.41 | 0.49 | 0.58 | 0.73 | 0.88 | 1.1 | 1.3 | 1.6 | 2.0 | 2.4 | 2.6 | 3 | 3 | 3 | |

Single-Phase 230V 50Hz

Unit = Upper values: lb-in / Lower values: N·m

| Model | Speed r/min Gear Ratio | 500 | 416 | 300 | 250 | 200 | 166 | 120 | 100 | 83 | 60 | 50 | 41 | 30 | 25 | 20 | 16 | 15 | 12.5 | 10 | 8.3 |
|--------------------------------------|---------------------------|----------|------------|----------|----------|------------|----------|-------------|-----------|-----------|-----------|-----------|-----------|-----------|-----------|-----------|-----------|------------|------------|------------|------------|
| | | 3 | 3.6 | 5 | 6 | 7.5 | 9 | 12.5 | 15 | 18 | 25 | 30 | 36 | 50 | 60 | 75 | 90 | 100 | 120 | 150 | 180 |
| 2RK6GN-CW(T)E / 2GN□KA | 1.0 | 1.2 | 1.7 | 2.1 | 2.6 | 3.1 | 4.3 | 5.2 | 6.2 | 7.8 | 9.3 | 11 | 14 | 17 | 21 | 25 | 26 | 26 | 26 | 26 | |
| | 0.12 | 0.14 | 0.20 | 0.24 | 0.30 | 0.36 | 0.50 | 0.60 | 0.71 | 0.89 | 1.1 | 1.3 | 1.6 | 1.9 | 2.4 | 2.9 | 3 | 3 | 3 | 3 | |

- Gearheads are sold separately.
- Enter the gear ratio in the box (□) within the model number. A colored background indicates gear shaft rotation in the same direction as the motor shaft; a white background indicates rotation in the opposite direction.
- The speed is calculated by dividing the motor's synchronous speed (50Hz: 1500 r/min, 60Hz: 1800 r/min) by the gear ratio. The actual speed is 2 ~ 20% less than the displayed value, depending on the size of the load.

■ Dimensions Scale 1/4, Unit = inch (mm)

2RK6GN-AWU
2RK6GN-CWE
2RK6GN-AUL

Weight (Mass): 1.5 lb.(0.7 kg)

2GN□KA

Weight (Mass): 0.88 lb.(0.4 kg)

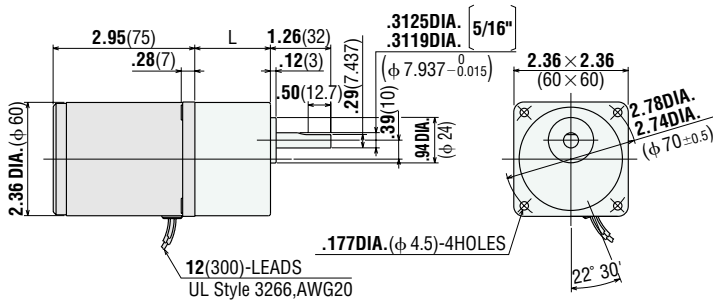

L = 1.18(30) **2GN3KA~18KA**
 L = 1.57(40) **2GN25KA~180KA**

2RK6GN-AWTU
2RK6GN-CWTE

Weight (Mass): 1.65 lb.(0.75 kg)

2GN□KA

Weight (Mass): 0.88 lb.(0.4 kg)

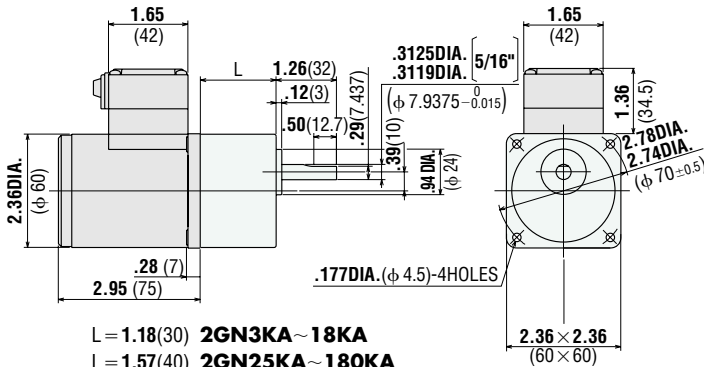

L = 1.18(30) **2GN3KA~18KA**
 L = 1.57(40) **2GN25KA~180KA**

Use cabtyre cable with the diameter of .27DIA.(φ 6.8)~.34DIA.(φ 8.6).

2RK6A-AWU
2RK6A-CWE

2RK6A-AULA Round Shaft Type

Weight (Mass): 1.5 lb.(0.7 kg)

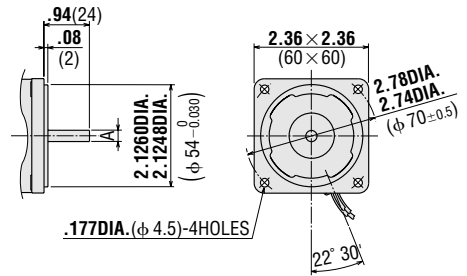

| Model | Shaft Diameter A |
|-------------------|---|
| 2RK6A-AWU | .2362DIA. (φ 6 ⁰ _{-0.012}) |
| 2RK6A-CWE | .2357DIA. (φ 6 ⁰ _{-0.012}) |
| 2RK6A-AULA | .2500DIA. [1/4"](φ 6.35 ⁰ _{-0.010}) .2496DIA. |

2RK6A-AWTU
2RK6A-CWTE

Round Shaft Type

Weight (Mass): 1.65 lb.(0.75 kg)

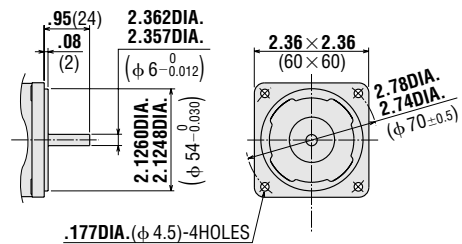

● Decimal Gearhead

2GN10XK

Weight (Mass): 0.44 lb.(0.2 kg)

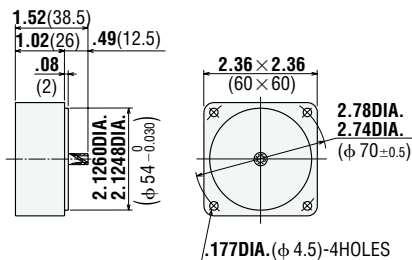

● **Capacitor** (included with the motor)

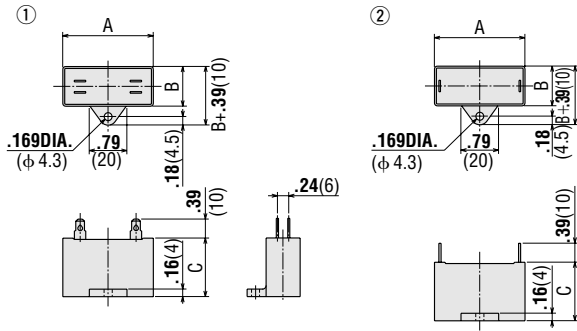

| Motor Model | Capacitor Model | Dimensions inch (mm) | | | Weight (Mass) oz (g) | Dimension No. |
|----------------------|-----------------|----------------------|--------|--------|----------------------|---------------|
| | | A | B | C | | |
| 2RK6GN-AW(T)U | CH35FAUL | 1.22 | 0.67 | 1.06 | 0.9 (25) | ① |
| 2RK6A-AW(T)U | | (31) | (17) | (27) | | |
| 2RK6GN-CW(T)E | CH08BFAUL | 1.22 | 0.67 | 1.06 | 0.9 (25) | ① |
| 2RK6A-CW(T)E | | (31) | (17) | (27) | | |
| 2RK6GN-AUL | CH23UL | 1.22 | 0.57 | 0.93 | 0.5 (15) | ② |
| 2RK6A-AULA | | (31) | (14.5) | (23.5) | | |

If you need to order a capacitor without a motor, add "-C" to the capacitor model number shown. A capacitor cap is always included with a capacitor.

■ **Wiring Diagrams** The direction of motor rotation is as viewed from the shaft end of the motor.

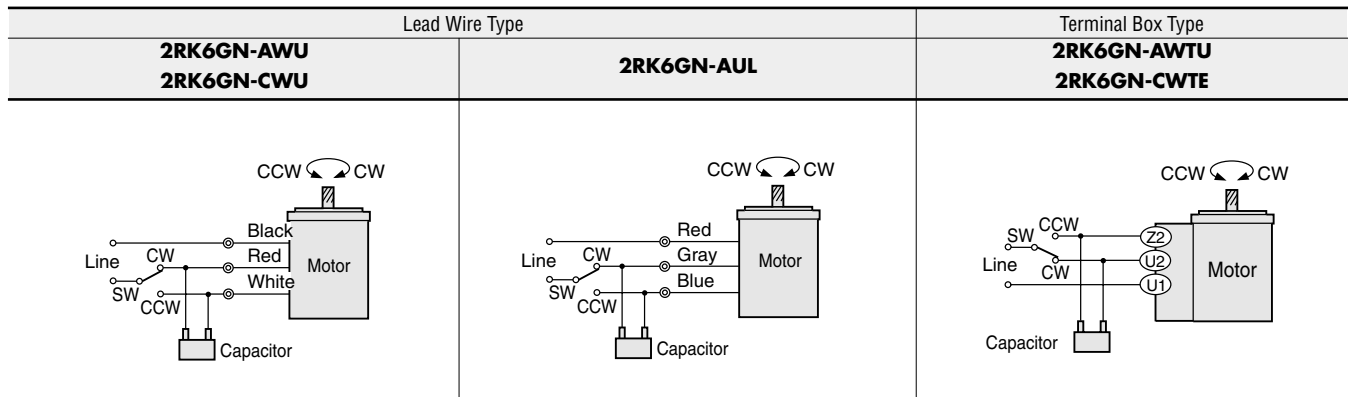

To rotate the motor in a clockwise (CW) direction, flip switch SW to CW.
 To rotate it in a counterclockwise (CCW) direction, flip switch SW to CCW.

■ **Accessories**

● **Motor Mounting Brackets**

Optional die-cast aluminum mounting brackets are available. They can be used to install motors without gearheads. See page [A-266] for the dimensions.
 Model name **SOL2U08**



● **Flexible Couplings**

Optional clamping couplings are available. See page[A-260] for the dimensions.





REVERSIBLE MOTORS

Single-Phase

15w (1/50 HP)

Frame Size 2.76 in.sq. (70mm sq.)



Specifications — 30 Minutes Rating



| Model | | Output Power | | Voltage | Frequency | Current | Starting Torque | | Rated Torque | | Rated Speed | Capacitor |
|-------------------|------------------|--------------|-------------|---------|-----------|---------|-----------------|------|--------------|------|-------------|-----------|
| Pinion Shaft Type | Round Shaft Type | HP | W | V AC | Hz | A | oz-in | mN·m | oz-in | mN·m | r/min | μF |
| 3RK15GN-AWU | 3RK15A-AWU | 1/50 | 15 | 110 | 60 | 0.42 | 13.9 | 100 | 14.6 | 105 | 1450 | 6 |
| | | | | 115 | 60 | 0.41 | 13.9 | 100 | 14.6 | 105 | 1450 | |
| 220 | 60 | | | 0.21 | 13.9 | 100 | 14.6 | 105 | 1450 | | | |
| 230 | 50 | | | 0.20 | 13.9 | 100 | 17.4 | 125 | 1200 | 1.5 | | |
| 3RK15GN-CWE | 3RK15A-CWE | 230 | 60 | 0.21 | 13.9 | 100 | 14.6 | 105 | 1450 | | | |
| | | 3RK15GN-AUL | 3RK15A-AULA | 115 | 60 | 0.36 | 10.4 | 75 | 13.9 | 100 | 1500 | 4.5 |

- Values shown for starting torque and rated torque are measured for operation without the brake applied.
- These products contain a built-in thermal protector. If a motor overheats for any reason, the thermal protector is opened and the motor stops. When the motor temperature drops, the thermal protector closes and the motor restarts. Be sure to turn the motor off before inspecting.
- The "U" and "E" at the end of the model name indicate that the unit includes a capacitor. These two letters are not listed on the motor nameplate. When the motor is approved under various safety standards, the nameplate is adopted.

Gearmotor—Torque Table

The permissible torque with decimal gearhead with a gear ratio of 10 is 43lb-in (5N-m).

Single-Phase 115V/230V 60Hz

Unit: lb-in / N-m Upper values: lb-in / Lower values: N-m

| Model | Speed r/min | 600 | 500 | 360 | 300 | 240 | 200 | 144 | 120 | 100 | 72 | 60 | 50 | 36 | 30 | 24 | 20 | 18 | 15 | 12 | 10 |
|----------------------|-------------|------|------|------|------|------|-----|------|-----|-----|-----|-----|-----|-----|----|----|----|-----|-----|-----|-----|
| | Gear Ratio | 3 | 3.6 | 5 | 6 | 7.5 | 9 | 12.5 | 15 | 18 | 25 | 30 | 36 | 50 | 60 | 75 | 90 | 100 | 120 | 150 | 180 |
| 3RK15GN-AWU / 3GN□KA | 2.2 | 2.7 | 3.7 | 4.4 | 5.5 | 6.7 | 9.2 | 11 | 13 | 17 | 20 | 24 | 30 | 36 | 43 | 43 | 43 | 43 | 43 | 43 | 43 |
| | 0.26 | 0.31 | 0.43 | 0.51 | 0.64 | 0.77 | 1.1 | 1.3 | 1.5 | 1.9 | 2.3 | 2.8 | 3.5 | 4.2 | 5 | 5 | 5 | 5 | 5 | 5 | 5 |
| 3RK15GN-AUL / 3GN□KA | 2.1 | 2.5 | 3.5 | 4.2 | 5.3 | 6.3 | 8.8 | 11 | 13 | 16 | 19 | 23 | 29 | 34 | 43 | 43 | 43 | 43 | 43 | 43 | 43 |
| | 0.24 | 0.29 | 0.41 | 0.49 | 0.61 | 0.73 | 1.0 | 1.2 | 1.5 | 1.8 | 2.2 | 2.6 | 3.3 | 4.0 | 5 | 5 | 5 | 5 | 5 | 5 | 5 |

Single-Phase 230V 50Hz

Unit: lb-in / N-m Upper values: lb-in / Lower values: N-m

| Model | Speed r/min | 500 | 416 | 300 | 250 | 200 | 166 | 120 | 100 | 83 | 60 | 50 | 41 | 30 | 25 | 20 | 16 | 15 | 12.5 | 10 | 8.3 |
|----------------------|-------------|------|------|------|------|------|-----|------|-----|-----|-----|-----|-----|----|----|----|----|-----|------|-----|-----|
| | Gear Ratio | 3 | 3.6 | 5 | 6 | 7.5 | 9 | 12.5 | 15 | 18 | 25 | 30 | 36 | 50 | 60 | 75 | 90 | 100 | 120 | 150 | 180 |
| 3RK15GN-CWE / 3GN□KA | 2.6 | 3.2 | 4.4 | 5.3 | 6.6 | 7.9 | 11 | 13 | 16 | 20 | 24 | 29 | 36 | 43 | 43 | 43 | 43 | 43 | 43 | 43 | 43 |
| | 0.30 | 0.36 | 0.51 | 0.61 | 0.76 | 0.91 | 1.3 | 1.5 | 1.8 | 2.3 | 2.7 | 3.3 | 4.1 | 5 | 5 | 5 | 5 | 5 | 5 | 5 | 5 |

- Gearheads are sold separately.
- Enter the gear ratio in the box (□) within the model number. A colored background indicates gear shaft rotation in the same direction as the motor shaft; a white background indicates rotation in the opposite direction.
- The speed is calculated by dividing the motor's synchronous speed (50 Hz: 1500 r/min, 60 Hz: 1800 r/min) by the gear ratio. The actual speed is 2 ~ 20% less than the displayed value, depending on the size of the load.

■ Dimensions Scale 1/4, Unit = inch (mm)

3RK15GN-AWU / **3GN□KA**
3RK15GN-CWE
3RK15GN-AUL
 Weight (Mass): 2.4 lb.(1.1 kg)

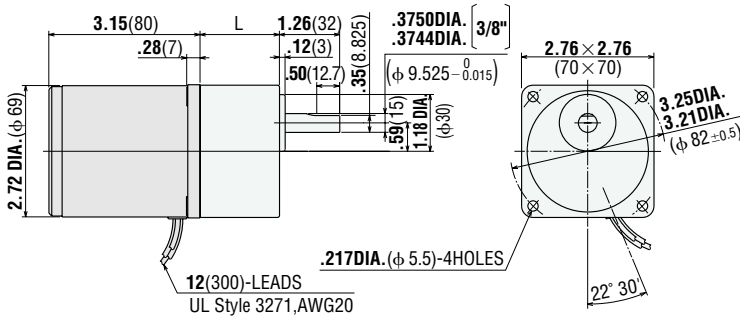

L = 1.26(32) **3GN3KA~18KA**
 L = 1.65(42) **3GN25KA~180KA**

3RK15A-AWU Round Shaft Type
3RK15A-CWE
3RK15A-AULA
 Weight (Mass): 2.4 lb.(1.1 kg)

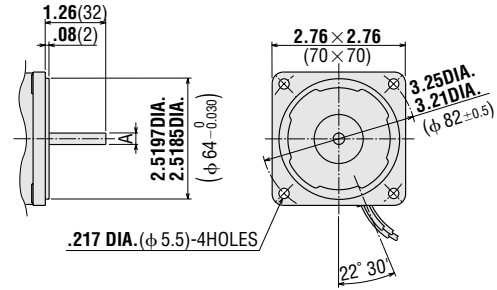

| Model | Shaft Diameter A |
|--------------------|--|
| 3RK15A-AWU | .2362DIA. (φ 6 ⁰ _{-0.012}) |
| 3RK15A-CWE | .2357DIA. (φ 6 ⁰ _{-0.012}) |
| 3RK15A-AULA | .2500DIA. [3/8"] (φ 6.35 ⁰ _{-0.010}) .2496DIA. [3/8"] (φ 6.35 ⁰ _{-0.010}) |

● Decimal Gearhead

3GN10XK Weight (Mass): 0.66 lb.(0.3 kg)

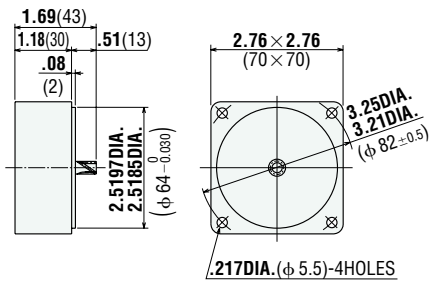

● Capacitor (included with the motor)

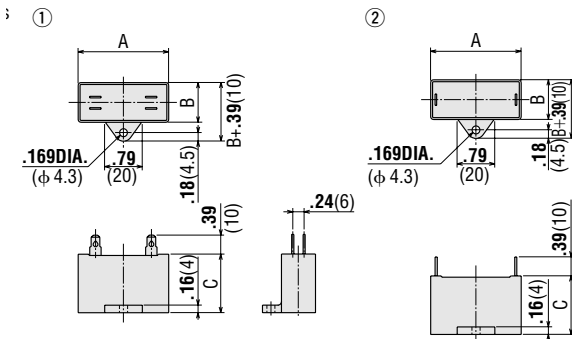

| Motor Model | Capacitor Model | Dimensions inch (mm) | | | Weight (Mass) oz (g) | Dimension No. |
|--------------------|-----------------|----------------------|-----------|-----------|----------------------|---------------|
| | | A | B | C | | |
| 3RK15GN-AWU | CH60CFAUL | 1.50 (38) | 0.83 (21) | 1.22 (31) | 1.4 (40) | ① |
| 3RK15A-AWU | | | | | | |
| 3RK15GN-CWE | CH15BFAUL | 1.50 (38) | 0.83 (21) | 1.22 (31) | 1.2 (35) | ① |
| 3RK15A-CWE | | | | | | |
| 3RK15GN-AUL | CH45UL | 1.46 (37) | 0.71 (18) | 1.06 (27) | 1.1 (30) | ② |
| 3RK15A-AULA | | | | | | |

If you need to order a capacitor without a motor, add "-C" to the capacitor model number shown. A capacitor cap is always included with a capacitor.

■ **Wiring Diagrams** The direction of motor rotation is as viewed from the shaft end of the motor.

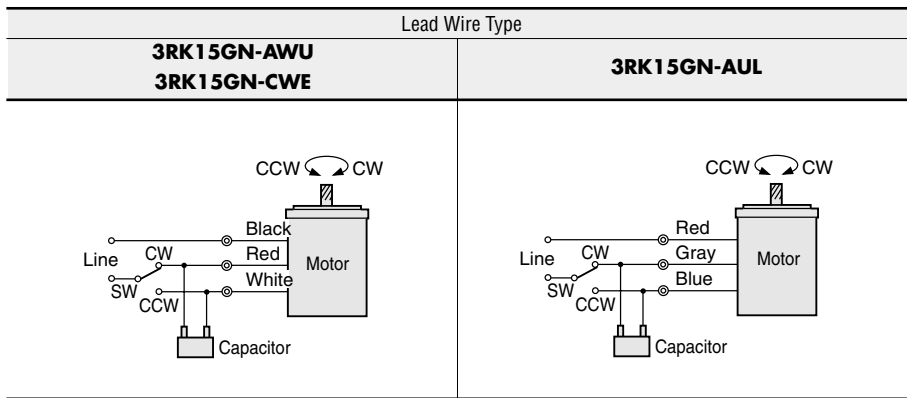

To rotate the motor in a clockwise(CW)direction, flip switch SW to CW.
To rotate it in a counterclockwise(CCW)direction, flip switch SW to CCW.

■ **Accessories**

● **Motor Mounting Brackets**

Optional die-cast aluminum mounting brackets are available. They can be used to install motors without gearheads. See page [A-266] for the dimensions.

Model name **SOL3U10**



● **Flexible Couplings**

Optional clamping couplings are available. See page[A-260] for the dimensions.



REVERSIBLE MOTORS

Single-Phase

20W (1/37 HP)

Frame Size 3.15 in.sq. (80mm sq.)



Specifications — 30 Minutes Rating

| Model | | Output Power | | Voltage | Frequency | Current | Starting Torque | | Rated Torque | | Rated Speed | Capacitor |
|--------------------|--------------------|--------------|----|---------|-----------|---------|-----------------|------|--------------|------|-------------|-----------|
| Pinion Shaft Type | Round Shaft Type | HP | W | V AC | Hz | A | oz-in | mN·m | oz-in | mN·m | r/min | μF |
| 4RJ20GB-AUL | 4RJ20A-AULA | 1/37 | 20 | 115 | 60 | 0.48 | 14.6 | 105 | 18.7 | 135 | 1500 | 6.0 |

- Values shown for starting torque and rated torque are measured for operation without the brake applied.
- The product contains a built-in thermal protector. When a motor overheats for any reason, the thermal protector is opened and the motor stops. When the motor temperature drops, the thermal protector closes and the motor restarts. Be sure to turn the motor off before inspecting.

Gearmotor—Torque Table

The permissible torque with decimal gearhead with a gear ratio of 10 is 43.4 lb-in (5N·m).

Unit = Upper values: lb-in / Lower values: N·m

| Model | Speed r/min | | Gear Ratio | | | | | | | | | | | | | | | | | | | | | |
|-----------------------------|-------------|------|------------|------|------|------|-----|-----|-----|-----|-----|-----|-----|----|----|----|----|----|----|----|-----|----|----|----|
| | 600 | 500 | 360 | 300 | 240 | 200 | 144 | 120 | 100 | 72 | 60 | 50 | 36 | 30 | 24 | 20 | 18 | 15 | 12 | 10 | 7.2 | 6 | 5 | |
| 4RJ20GB-AUL / 4GB□KA | 2.8 | 3.4 | 4.7 | 5.7 | 7.1 | 8.5 | 12 | 14 | 17 | 21 | 26 | 31 | 39 | 43 | 43 | 43 | 43 | 43 | 43 | 43 | 43 | 43 | 43 | 43 |
| | 0.33 | 0.39 | 0.55 | 0.66 | 0.82 | 0.98 | 1.4 | 1.6 | 2.0 | 2.5 | 3.0 | 3.5 | 4.5 | 5 | 5 | 5 | 5 | 5 | 5 | 5 | 5 | 5 | 5 | 5 |

- Gearheads are sold separately.
- Enter the gear ratio in the box (□) within the model number. A colored background indicates gear shaft rotation in the same direction as the motor shaft; a white background indicates rotation in the opposite direction.
- The speed is calculated by dividing the motor's synchronous speed (60 Hz: 1800 r/min) by the gear ratio. The actual speed is 2 ~ 20% less than the displayed value, depending on the size of the load.

Wiring Diagram

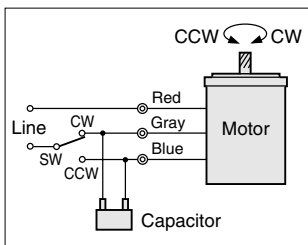

To rotate the motor in a clockwise (CW) direction, flip switch SW to CW.
To rotate it in a counterclockwise (CCW) direction, flip switch SW to CCW.

The direction of motor rotation is as viewed from the shaft end of the motor.

Dimensions Scale 1/4, Unit = inch (mm)

4RJ20GB-AUL

Weight (Mass): 3.1 lb.(1.4 kg)

/ 4GB□KA

Weight (Mass): 1.43 lb.(0.65 kg)

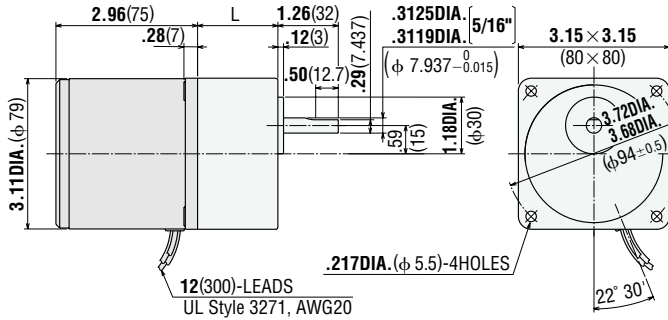

12(300)-LEADS
UL Style 3271, AWG20
L = 1.26(32) **4GB3KA~18KA**
L = 1.67(42.5) **4GB25KA~360KA**

4RJ20A-AULA Round Shaft Type

Weight (Mass): 3.1 lb.(1.4 kg)

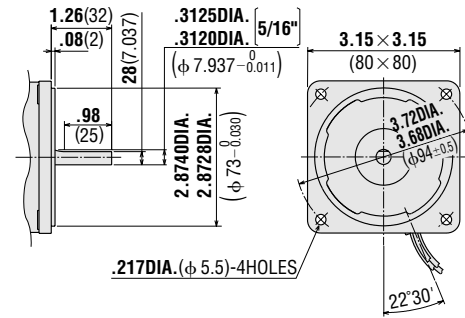

Decimal Gearhead

4GB10XK

Weight (Mass): 0.77 lb.(0.35 kg)

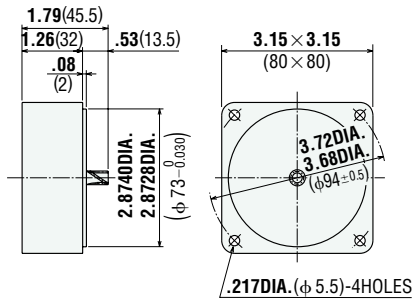

Capacitor (included with the motor)

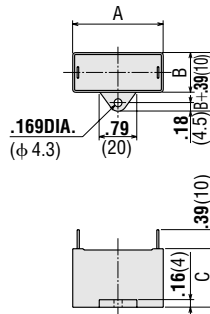

| Motor Model | Capacitor Model | Dimensions inch (mm) | | | Weight (Mass) oz (g) |
|-------------|-----------------|----------------------|------|------|----------------------|
| | | A | B | C | |
| 4RJ20GB-AUL | CH6OUL | 1.50 | 0.75 | 1.14 | 1.1 (30) |
| 4RJ20A-AULA | | (38) | (19) | (29) | |

If you need to order a capacitor without a motor, add "-C" to the capacitor model number shown. A capacitor cap is always included with a capacitor.

Accessories

Motor Mounting Brackets

Optional die-cast aluminum mounting brackets are available. They can be used to install motors without gearheads. See page [A-266] for the dimensions.

Model name **SOL4U10**



Flexible Couplings

Optional clamping couplings are available. See page[A-260] for the dimensions.



REVERSIBLE MOTORS

Single-Phase

25W (1/30 HP)

Frame Size 3.15 in.sq. (80mm sq.)



Specifications — 30 Minutes Rating



| Model | | Output Power | Voltage | Frequency | Current | Starting Torque | | Rated Torque | | Rated Speed | Capacitor | | |
|-------------------------------------|---------------------------------------|--------------------------------------|---------|-----------|---------|-----------------|-------|--------------|-------|-------------|-----------|-------|----|
| Upper Model Name: Pinion Shaft Type | Lower Model Name(): Round Shaft Type | | | | | oz-in | mN·m | oz-in | mN·m | | | r/min | μF |
| Lead Wire Type | Terminal Box Type | HP | W | V AC | Hz | A | oz-in | mN·m | oz-in | mN·m | r/min | μF | |
| Dimension ① | Dimension ② | | | | | | | | | | | | |
| SA | 4RK25GN-AWU (4RK25A-AWU) | 4RK25GN-AWTU (4RK25A-AWTU) | 1/30 | 25 | 110 | 60 | 0.54 | 19.4 | 140 | 23.6 | 170 | 1450 | 8 |
| | 115 | | | | 60 | | | | | | | | |
| SA | 4RK25GN-CWE (4RK25A-CWE) | 4RK25GN-CWTE (4RK25A-CWTE) | 1/30 | 25 | 220 | 60 | 0.28 | 19.4 | 140 | 23.6 | 170 | 1450 | 2 |
| | | | | | 230 | 50 | | | | | | | |
| | | | | | 230 | 60 | | | | | | | |
| SE | 4RK25GN-AUL (4RK25A-AULA) | — | 1/27.5 | 27 | 115 | 60 | 0.55 | 16.0 | 115 | 23.6 | 170 | 1550 | 7 |

- Values shown for starting torque and rated torque are measured for operation without the brake applied.
- The product contains a built-in thermal protector. When a motor overheats for any reason, the thermal protector is opened and the motor stops. When the motor temperature drops, the thermal protector closes and the motor restarts. Be sure to turn the motor off before inspecting.
- The "U" and "E" at the end of the model name indicate that the unit includes a capacitor. These two letters are not listed on the motor nameplate. When the motor is approved under various safety standards, the nameplate is adopted.

Gearmotor—Torque Table

The permissible torque with decimal gearhead with a gear ratio of 10:1 is 70 lb-in (8N·m). The value is 52 lb-in (6N·m) when 25:1~36:1 gearheads are connected.

Single-Phase 115V/230V 60Hz

Unit= Upper values: lb-in/Lower values: N·m

| Model | Speed r/min Gear Ratio | 600 | 500 | 360 | 300 | 240 | 200 | 144 | 120 | 100 | 72 | 60 | 50 | 36 | 30 | 24 | 20 | 18 | 15 | 12 | 10 |
|--|---------------------------|----------|------------|----------|----------|------------|----------|-------------|-----------|-----------|-----------|-----------|-----------|-----------|-----------|-----------|-----------|------------|------------|------------|------------|
| | | 3 | 3.6 | 5 | 6 | 7.5 | 9 | 12.5 | 15 | 18 | 25 | 30 | 36 | 50 | 60 | 75 | 90 | 100 | 120 | 150 | 180 |
| 4RK25GN-AWU 4RK25GN-AWTU 4RK25GN-CWE 4RK25GN-CWTE | 4GN □ KA | 3.6 | 4.3 | 6.0 | 7.2 | 9.0 | 11 | 15 | 18 | 22 | 27 | 32 | 39 | 49 | 58 | 69 | 69 | 69 | 69 | 69 | 69 |
| | | 0.41 | 0.50 | 0.69 | 0.83 | 1.0 | 1.2 | 1.7 | 2.1 | 2.5 | 3.1 | 3.7 | 4.5 | 5.6 | 6.7 | 8 | 8 | 8 | 8 | 8 | 8 |
| 4RK25GN-AUL | 4GN □ KA | 3.6 | 4.3 | 6.0 | 7.2 | 9.0 | 11 | 15 | 18 | 22 | 27 | 32 | 39 | 49 | 58 | 69 | 69 | 69 | 69 | 69 | 69 |
| | | 0.41 | 0.50 | 0.69 | 0.83 | 1.0 | 1.2 | 1.7 | 2.1 | 2.5 | 3.1 | 3.7 | 4.5 | 5.6 | 6.7 | 8 | 8 | 8 | 8 | 8 | 8 |

Single-Phase 230V 50Hz

Unit= Upper values: lb-in/Lower values: N·m

| Model | Speed r/min Gear Ratio | 500 | 416 | 300 | 250 | 200 | 166 | 120 | 100 | 83 | 60 | 50 | 41 | 30 | 25 | 20 | 16 | 15 | 12.5 | 10 | 8.3 |
|---|---------------------------|----------|------------|----------|----------|------------|----------|-------------|-----------|-----------|-----------|-----------|-----------|-----------|-----------|-----------|-----------|------------|------------|------------|------------|
| | | 3 | 3.6 | 5 | 6 | 7.5 | 9 | 12.5 | 15 | 18 | 25 | 30 | 36 | 50 | 60 | 75 | 90 | 100 | 120 | 150 | 180 |
| 4RK25GN-CWE 4RK25GN-CWTE | 4GN □ KA | 4.3 | 5.2 | 7.2 | 8.7 | 11 | 13 | 18 | 22 | 26 | 33 | 39 | 47 | 59 | 69 | 69 | 69 | 69 | 69 | 69 | 69 |
| | | 0.50 | 0.60 | 0.83 | 1.0 | 1.2 | 1.5 | 2.1 | 2.5 | 3.0 | 3.7 | 4.5 | 5.4 | 6.8 | 8 | 8 | 8 | 8 | 8 | 8 | 8 |

- Gearheads are sold separately.
- Enter the gear ratio in the box (□) within the model number. A colored background indicates gear shaft rotation in the same direction as the motor shaft; a white background indicates rotation in the opposite direction.
- The speed is calculated by dividing the motor's synchronous speed (50 Hz: 1500 r/min, 60 Hz: 1800 r/min) by the gear ratio. The actual speed is 2 ~ 20% less than the displayed value, depending on the size of the load.

• Right-Angle gearhead may be connected. See page [A-216] for more information.

■ Dimensions Scale 1/4, Unit = inch (mm)

① **4RK25GN-AWU**
4RK25GN-CWE
4RK25GN-AUL

Weight (Mass): 3.3 lb.(1.5 kg)

4GN□KA

Weight (Mass): 1.43 lb.(0.65 kg)

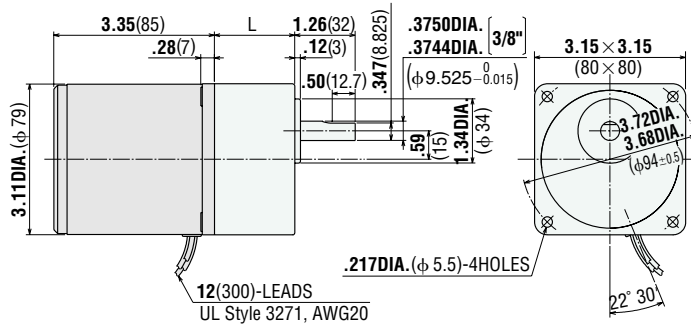

L = 1.26(32) **4GN3KA~18KA**

L = 1.67(42.5) **4GN25KA~180KA**

4RK25A-AWU Round Shaft Type

4RK25A-CWE
4RK25A-AULA

Weight (Mass): 3.3 lb.(1.5 kg)

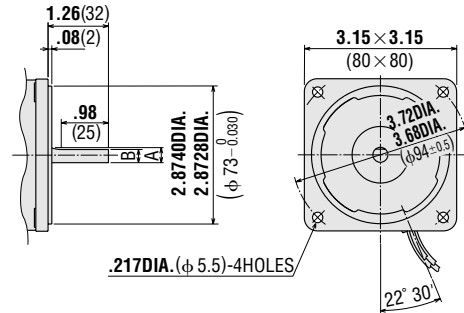

| Model | A | B |
|--------------------|-------------------------------------|------------|
| 4RK25A-AWU | .3150DIA. (φ 8-0.015) | .28(7) |
| 4RK25A-CWE | .3144DIA. | |
| 4RK25A-AULA | .3125DIA. [5/16"](φ 7.937-0.011) | .28(7.037) |
| | .3120DIA. | |

② **4RK25GN-AWTU**
4RK25GN-CWTE

Weight (Mass): 3.7 lb.(1.7 kg)

4GN□KA

Weight (Mass): 1.43 lb.(0.65 kg)

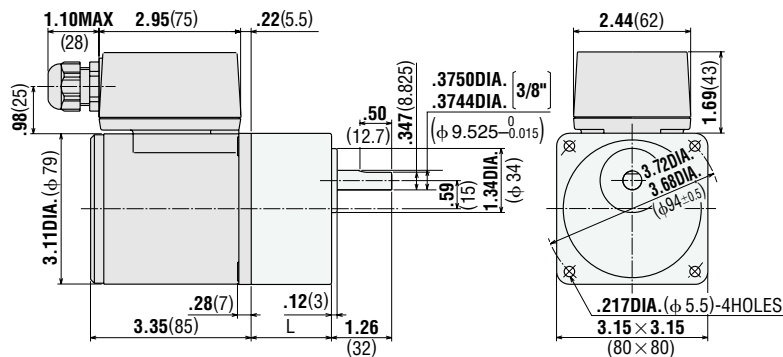

L = 1.26(32) **4GN3KA~18KA**

L = 1.67(42.5) **4GN25KA~180KA**

Use cabtyre cable with the diameter of .24DIA.(φ 6)~.47DIA.(φ 12).

4RK25A-AWTE Round Shaft Type

4RK25A-CWTE

Weight (Mass): 3.7 lb.(1.7 kg)

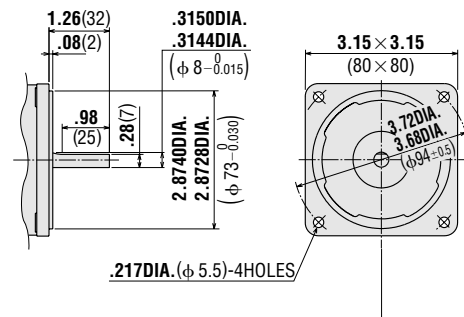

● Decimal Gearhead

4GN10XK Weight (Mass): 0.88 lb.(0.4 kg)

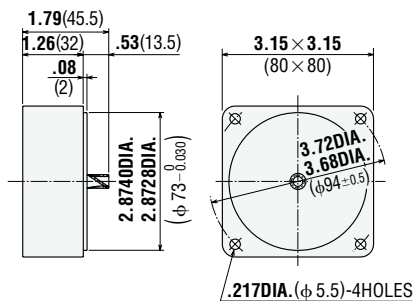

● **Capacitor** (included with the motor)

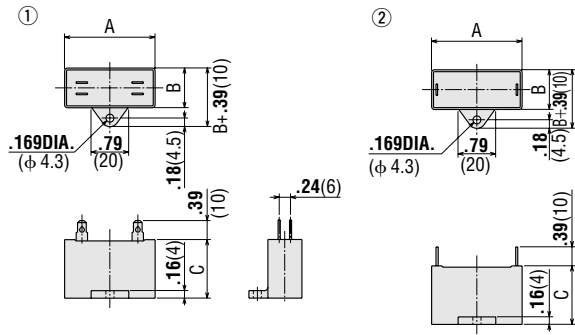

| Motor Model | Capacitor Model | Dimensions inch (mm) | | | Weight (Mass) oz (g) | Dimension No. |
|---|-----------------|----------------------|-----------|-----------|----------------------|---------------|
| | | A | B | C | | |
| 4R25GN-AW(T)U 4R25A-AW(T)U | CH80CFAUL | 1.89 (48) | 0.75 (19) | 1.14 (29) | 1.41 (40) | ① |
| 4R25GN-CW(T)E 4R25A-CW(T)E | CH20BFAUL | 1.89 (48) | 0.75 (19) | 1.14 (29) | 1.23 (35) | ① |
| 4R25GN-AUL 4RK25A-AULA | CH70UL | 1.50 (38) | 0.83 (21) | 1.22 (31) | 1.23 (35) | ② |

If you need to order a capacitor without a motor, add "-C" to the capacitor model number shown. A capacitor cap is always included with a capacitor.

■ **Wiring Diagrams** The direction of motor rotation is as viewed from the shaft end of the motor.

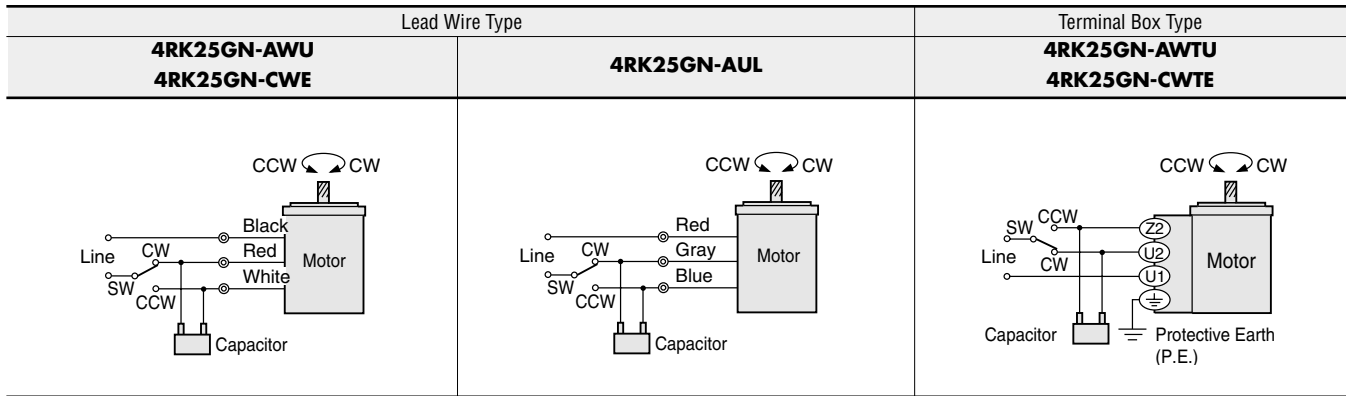

To rotate the motor in a clockwise(CW)direction, flip switch SW to CW.
To rotate it in a counterclockwise(CCW)direction, flip switch SW to CCW.

■ **Right-Angle Gearheads**

The right-angle gearhead provides an output shaft that is at a right angle to the motor's output shaft. See page [A-216] for specifications and other information.

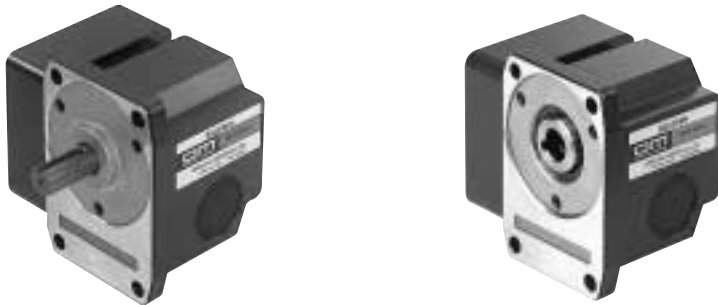

■ **Accessories**

● **Motor Mounting Brackets**

Optional die-cast aluminum mounting brackets are available. They can be used to install motors without gearheads. See page [A-266] for the dimensions. Model name **SOL4U10**



● **Flexible Couplings**

Optional clamping couplings are available. See page[A-260] for the dimensions.





REVERSIBLE MOTORS

Single-Phase

40w (1/18.5 HP)

Frame Size 3.54 in.sq. (90mm sq.)



Specifications — 30 Minutes Rating



| Model Upper Model Name:Pinion Shaft Type Lower Model Name():Round Shaft Type | | Output Power | | Voltage | Frequency | Current | Starting Torque | | Rated Torque | | Rated Speed | Capacitor | | | |
|---|----------------------------------|--------------|----|---------|-----------|---------|-----------------|------|--------------|------|-------------|-----------|------|-----|------|
| Lead Wire Type Dimension ① | Terminal Box Type Dimension ② | HP | W | V AC | Hz | A | oz-in | mN·m | oz-in | mN·m | r/min | μF | | | |
| 5RK40GN-AWU (5RK40A-AWU) | 5RK40GN-AWTU (5RK40A-AWTU) | | | 110 | 60 | 0.81 | 36.1 | 260 | 37.5 | 270 | 1450 | 12 | | | |
| | | | | 115 | | | | | | | | | | | |
| 5RK40GN-CWE (5RK40A-CWE) | 5RK40GN-CWTE (5RK40A-CWTE) | | | 220 | 50 | 0.46 | 36.1 | 260 | 36.1 | 260 | 1500 | 3.5 | | | |
| | | 1/18.5 | 40 | 230 | | | | | | | 270 | | 43.7 | 315 | 1250 |
| | | | | 230 | | | | | | | 260 | | 36.1 | 260 | 1500 |
| 5RK40GN-AUL (5RK40A-AULA) | — | | | 115 | 60 | 0.87 | 36.1 | 260 | 36.1 | 260 | 1550 | 12 | | | |

- Values shown for starting torque and rated torque are measured for operation without the brake applied.
- The product contains a built-in thermal protector. When a motor overheats for any reason, the thermal protector is opened and the motor stops. When the motor temperature drops, the thermal protector closes and the motor restarts. Be sure to turn the motor off before inspecting.
- The "U" and "E" at the end of the model name indicate that the unit includes a capacitor. These two letters are not listed on the motor nameplate. When the motor is approved under various safety standards, the nameplate is adopted.

Gearmotor — Torque Table

The permissible torque with decimal gearhead with a gear ratio of 10:1 is 87 lb-in (10N·m).

• Right-Angle gearhead may be connected. See page [A-216] for more information.

Single-Phase 115V/230V 60Hz

Unit=Upper values: lb-in/Lower values: N·m

| Model | Speed r/min | 600 | 500 | 360 | 300 | 240 | 200 | 144 | 120 | 100 | 72 | 60 | 50 | 36 | 30 | 24 | 20 | 18 | 15 | 12 | 10 |
|---|-------------|------|-----|-----|-----|-----|-----|------|-----|-----|-----|-----|-----|----|----|----|----|-----|-----|-----|-----|
| | Gear Ratio | 3 | 3.6 | 5 | 6 | 7.5 | 9 | 12.5 | 15 | 18 | 25 | 30 | 36 | 50 | 60 | 75 | 90 | 100 | 120 | 150 | 180 |
| 5RK40GN-AWU / 5GN□KA 5RK40GN-AWTU / 5GN□KA | 5.7 | 6.8 | 9.5 | 11 | 14 | 17 | 24 | 28 | 34 | 43 | 51 | 62 | 77 | 87 | 87 | 87 | 87 | 87 | 87 | 87 | 87 |
| | 0.66 | 0.79 | 1.1 | 1.3 | 1.6 | 2.0 | 2.7 | 3.3 | 3.9 | 4.9 | 5.9 | 7.1 | 8.9 | 10 | 10 | 10 | 10 | 10 | 10 | 10 | 10 |
| 5RK40GN-CWE / 5GN□KA 5RK40GN-CWTE / 5GN□KA | 5.5 | 6.6 | 9.1 | 11 | 14 | 16 | 23 | 27 | 33 | 41 | 49 | 59 | 74 | 87 | 87 | 87 | 87 | 87 | 87 | 87 | 87 |
| | 0.63 | 0.76 | 1.1 | 1.3 | 1.6 | 1.9 | 2.6 | 3.2 | 3.8 | 4.7 | 5.7 | 6.8 | 8.6 | 10 | 10 | 10 | 10 | 10 | 10 | 10 | 10 |
| 5RK40GN-AUL / 5GN□KA | 5.5 | 6.6 | 9.1 | 11 | 14 | 16 | 23 | 27 | 33 | 41 | 49 | 59 | 74 | 87 | 87 | 87 | 87 | 87 | 87 | 87 | 87 |
| | 0.63 | 0.76 | 1.1 | 1.3 | 1.6 | 1.9 | 2.6 | 3.2 | 3.8 | 4.7 | 5.7 | 6.8 | 8.6 | 10 | 10 | 10 | 10 | 10 | 10 | 10 | 10 |

Single-Phase 230V 50Hz

Unit=Upper values: lb-in/Lower values: N·m

| Model | Speed r/min | 500 | 416 | 300 | 250 | 200 | 166 | 120 | 100 | 83 | 60 | 50 | 41 | 30 | 25 | 20 | 16 | 15 | 12.5 | 10 | 8.3 |
|---|-------------|------|-----|-----|-----|-----|-----|------|-----|-----|-----|-----|----|----|----|----|----|-----|------|-----|-----|
| | Gear Ratio | 3 | 3.6 | 5 | 6 | 7.5 | 9 | 12.5 | 15 | 18 | 25 | 30 | 36 | 50 | 60 | 75 | 90 | 100 | 120 | 150 | 180 |
| 5RK40GN-CWE / 5GN□KA 5RK40GN-CWTE / 5GN□KA | 6.6 | 8.0 | 11 | 13 | 17 | 20 | 28 | 33 | 40 | 50 | 60 | 72 | 87 | 87 | 87 | 87 | 87 | 87 | 87 | 87 | 87 |
| | 0.77 | 0.92 | 1.3 | 1.5 | 1.9 | 2.3 | 3.2 | 3.8 | 4.6 | 5.7 | 6.9 | 8.3 | 10 | 10 | 10 | 10 | 10 | 10 | 10 | 10 | 10 |

- Gearheads are sold separately.
- Enter the gear ratio in the box (□) within the model number. A colored background indicates gear shaft rotation in the same direction as the motor shaft; a white background indicates rotation in the opposite direction.
- The speed is calculated by dividing the motor's synchronous speed (50 Hz: 1500 r/min, 60 Hz: 1800 r/min) by the gear ratio. The actual speed is 2 ~ 20% less than the displayed value, depending on the size of the load.

■ Dimensions Scale 1/4, Unit = inch (mm)

① **5RK40GN-AWU**
5RK40GN-CWE
5RK40GN-AUL

Weight (Mass): 5.5 lb.(2.5 kg)

5GN□KA

Weight (Mass): 3.3 lb.(1.5 kg)

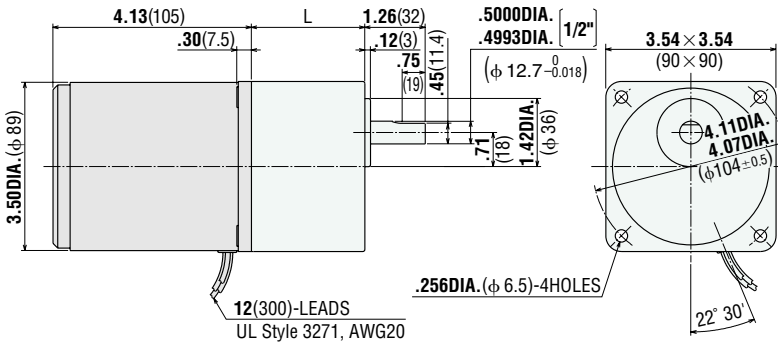

L = 1.65(42) **5GN3KA~18KA**

L = 2.36(60) **5GN25KA~180KA**

5RK40A-AWU
5RK40A-CWE

5RK40A-AULA Round Shaft Type

Weight (Mass): 5.5 lb.(2.5 kg)

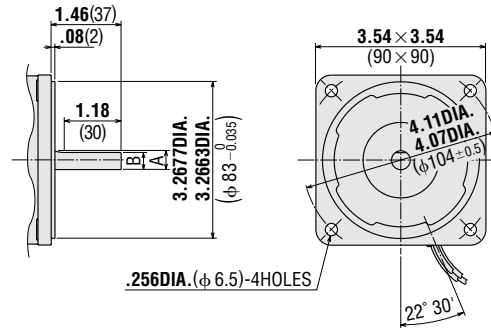

| Model | A | B |
|--------------------|-------------------------------|------------|
| 5RK40A-AWU | .3937DIA. (φ 10 -0.015) | .35(9) |
| 5RK40A-CWE | .3931DIA. (φ 10 -0.015) | .35(9) |
| 5RK40A-AULA | .3750DIA. (φ 9.525 -0.011) | .35(8.825) |
| | .3746DIA. | |

② **5RK40GN-AWTU**
5RK40GN-CWTE

Weight (Mass): 5.7 lb.(2.6 kg)

5GN□KA

Weight (Mass): 3.3 lb.(1.5 kg)

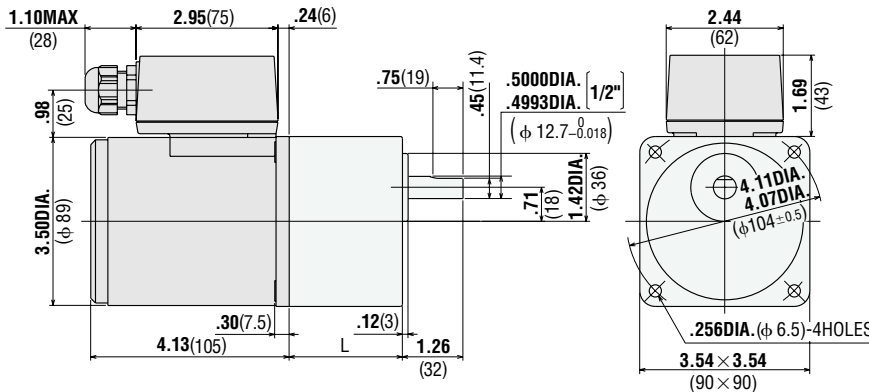

L = 1.65(42) **5GN3KA~18KA**

L = 2.36(60) **5GN25KA~180KA**

Use cabtyre cable with the diameter of .24DIA. (φ 6) ~ .47DIA. (φ 12).

5RK40A-AWTU
5RK40A-CWTE

Round Shaft Type

Weight (Mass): 5.7 lb.(2.6 kg)

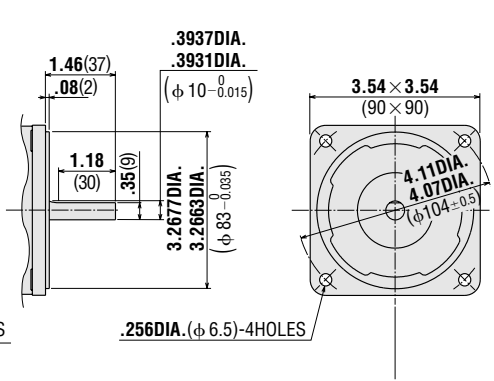

● Decimal Gearhead

5GN10XK Weight (Mass): 1.32 lb.(0.6 kg)

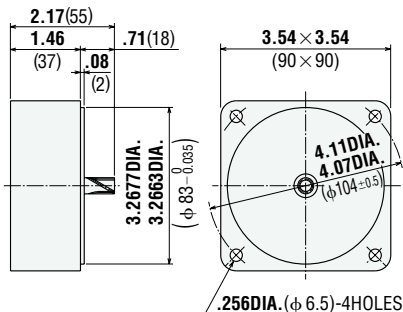

● **Capacitor** (included with the motor)

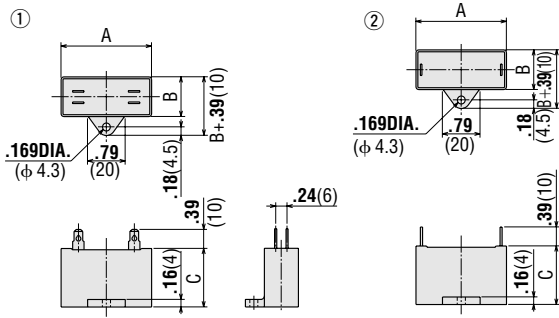

| Motor Model | Capacitor Model | Dimensions inch (mm) | | | Weight (Mass) oz (g) | Dimension No. |
|-----------------------|-----------------|----------------------|------|------|----------------------|---------------|
| | | A | B | C | | |
| 5RK40GN-AW(T)U | CH1 20CFAUL | 2.28 | 0.83 | 1.22 | 1.76 (50) | ① |
| 5RK40A-AW(T)U | | (58) | (21) | (31) | | |
| 5RK40GN-CW(T)E | CH35BFAUL | 2.28 | 0.87 | 1.38 | 1.94 (55) | ① |
| 5RK40A-CW(T)E | | (58) | (22) | (35) | | |
| 5RK40GN-AUL | CH1 20UL | 1.89 | 0.83 | 1.22 | 1.55 (44) | ② |
| 5RK40A-AULA | | (48) | (21) | (31) | | |

If you need to order a capacitor without a motor, add "-C" to the capacitor model number shown. A capacitor cap is always included with a capacitor.

■ **Wiring Diagrams** The direction of motor rotation is as viewed from the shaft end of the motor.

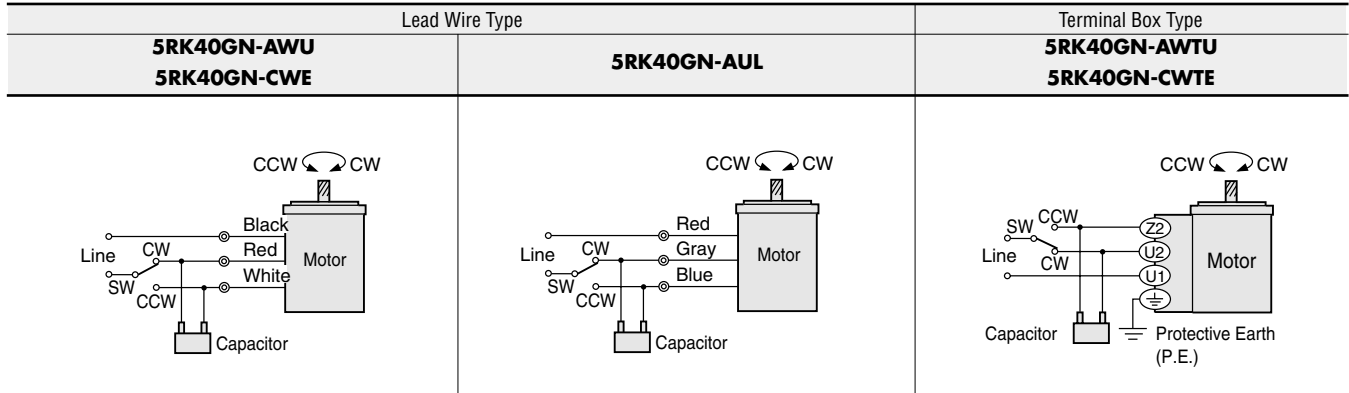

To rotate the motor in a clockwise(CW)direction, flip switch SW to CW.
 To rotate it in a counterclockwise(CCW)direction, flip this switch to CCW.

■ **Right-Angle Gearheads**

The right-angle gearhead provides an output shaft that is at a right angle to the motor's output shaft.
 See page [A-216] for specifications and other information.

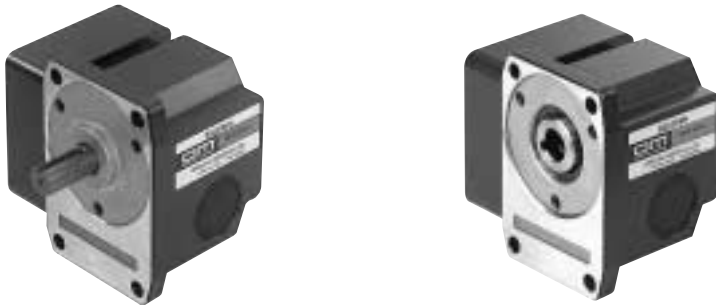

■ **Accessories**

● **Motor Mounting Brackets**

Optional die-cast aluminum mounting brackets are available. They can be used to install motors without gearheads. See page [A-266] for the dimensions.
 Model name **SOL5UA**



● **Flexible Couplings**

Optional clamping couplings are available. See page[A-260] for the dimensions.



REVERSIBLE MOTORS

Single-Phase

60W (1/12.5 HP)

Frame Size 3.54 in.sq. (90mm sq.)



Specifications — 30 Minutes Rating

| Model | | Output Power | Voltage | Frequency | Current | Starting Torque | | Rated Torque | | Rated Speed | Capacitor | | |
|-------------------------------------|---------------------------------------|----------------------------|---------|-----------|---------|-----------------|-------|--------------|-------|-------------|-----------|------|----|
| Upper Model Name: Pinion Shaft Type | Lower Model Name(): Round Shaft Type | | | | | oz-in | mN·m | oz-in | mN·m | | | | |
| Lead Wire Type | Terminal Box Type | HP | W | V AC | Hz | A | oz-in | mN·m | oz-in | mN·m | r/min. | μF | |
| Dimension ① | Dimension ② | | | | | | | | | | | | |
| UL | 5RK60GU-AWU (5RK60A-AWU) | 5RK60GU-AWTU (5RK60A-AWTU) | 1/12.5 | 60 | 110 | 60 | 1.24 | 52.8 | 380 | 56.2 | 405 | 1450 | 20 |
| | | | | | 115 | 60 | 0.67 | 52.8 | 380 | 56.2 | 405 | 1450 | |
| UL | 5RK60GU-CWE (5RK60A-CWE) | 5RK60GU-CWTE (5RK60A-CWTE) | 1/12.5 | 60 | 220 | 60 | 0.61 | 52.8 | 380 | 56.2 | 405 | 1450 | |
| | | | | | 230 | 50 | 0.61 | 65.3 | 470 | 68.0 | 490 | 1200 | 5 |
| | | | | | 230 | 60 | 0.67 | 52.8 | 380 | 56.2 | 405 | 1450 | |
| UL | 5RK60GU-AFUL | — | | | 115 | 60 | 1.25 | 51.4 | 370 | 51.4 | 370 | 1600 | 20 |

- Values shown for starting torque and rated torque are measured for operation without the brake applied.
- The product contains a built-in thermal protector. When a motor overheats for any reason, the thermal protector is opened and the motor stops. When the motor temperature drops, the thermal protector closes and the motor restarts. Be sure to turn the motor off before inspecting.
- The "U" and "E" at the end of the model name indicate that the unit includes a capacitor. These two letters are not listed on the motor nameplate. When the motor is approved under various safety standards, the nameplate is adopted.

Gearmotor—Torque Table

The permissible torque with decimal gearhead with a gear ratio of 10:1 is 174 lb-in (20N·m).

• Right-Angle gearhead may be connected. See page [A-216] for more information.

Single-Phase 115V/230V 60Hz

Unit=Upper values: lb-in/Lower values: N·m

| Model | Speed r/min | Gear Ratio | | | | | | | | | | | | | | | | | | | |
|--|-------------|------------|-----|-----|-----|-----|-----|------|-----|-----|-----|-----|-----|-----|------|-----|-----|-----|-----|-----|-----|
| | | 3 | 3.6 | 5 | 6 | 7.5 | 9 | 12.5 | 15 | 18 | 25 | 30 | 36 | 50 | 60 | 75 | 90 | 100 | 120 | 150 | 180 |
| 5RK60GU-AWU 5RK60GU-AWTU 5RK60GU-CWE 5RK60GU-CWTE | 5GU□KA | 8.5 | 10 | 14 | 17 | 21 | 26 | 32 | 38 | 46 | 58 | 70 | 83 | 116 | 139 | 155 | 174 | 174 | 174 | 174 | 174 |
| | 5GU□KA | 0.98 | 1.2 | 1.6 | 2 | 2.5 | 3.0 | 3.7 | 4.4 | 5.3 | 6.7 | 8.0 | 9.6 | 13 | 16 | 18 | 20 | 20 | 20 | 20 | 20 |
| 5RK60GU-AFUL | 5GU□KA | 7.8 | 9.4 | 13 | 16 | 20 | 23 | 29 | 35 | 42 | 53 | 64 | 76 | 106 | 127 | 142 | 171 | 174 | 174 | 174 | 174 |
| | 5GU□KA | 0.9 | 1.1 | 1.5 | 1.8 | 2.2 | 2.7 | 3.4 | 4.1 | 4.9 | 6.1 | 7.3 | 8.8 | 12 | 15.0 | 16 | 20 | 20 | 20 | 20 | 20 |

Single-Phase 230V 50Hz

Unit=Upper values: lb-in/Lower values: N·m

| Model | Speed r/min | Gear Ratio | | | | | | | | | | | | | | | | | | | |
|-----------------------------|-------------|------------|-----|----|-----|-----|-----|------|-----|-----|-----|-----|-----|-----|-----|-----|-----|-----|-----|-----|-----|
| | | 3 | 3.6 | 5 | 6 | 7.5 | 9 | 12.5 | 15 | 18 | 25 | 30 | 36 | 50 | 60 | 75 | 90 | 100 | 120 | 150 | 180 |
| 5RK60GU-CWE 5RK60GU-CWTE | 5GU□KA | 10 | 12 | 17 | 21 | 26 | 31 | 39 | 47 | 56 | 70 | 84 | 101 | 140 | 168 | 174 | 174 | 174 | 174 | 174 | 174 |
| | 5GU□KA | 1.2 | 1.4 | 2 | 2.4 | 3 | 3.6 | 4.5 | 5.4 | 6.4 | 8.1 | 9.7 | 12 | 16 | 19 | 20 | 20 | 20 | 20 | 20 | 20 |

- Gearheads are sold separately.
- Enter the gear ratio in the box (□) within the model number. A colored background indicates gear shaft rotation in the same direction as the motor shaft; a white background indicates rotation in the opposite direction.
- The speed is calculated by dividing the motor's synchronous speed (50 Hz: 1500 r/min, 60 Hz: 1800 r/min) by the gear ratio. The actual speed is 2 ~ 20% less than the displayed value, depending on the size of the load.

Dimensions Scale 1/4, Unit = inch (mm)

① 5RK60GU-AWU

5RK60GU-CWE

5RK60GU-AFUL

Weight (Mass): 6.0 lb.(2.7 kg)

5GU□KA

Weight (Mass): 3.3 lb.(1.5 kg)

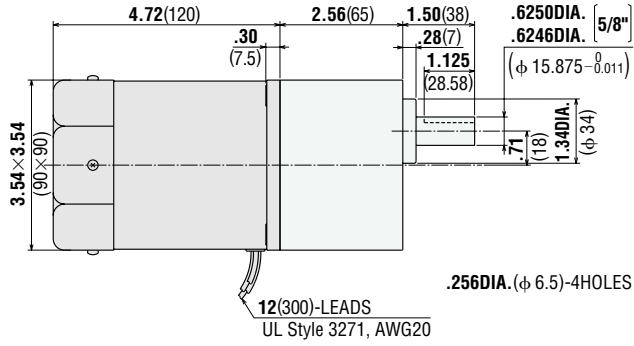

5RK60A-AWU

5RK60A-CWE Round Shaft Type

Weight (Mass): 6.0 lb.(2.7 kg)

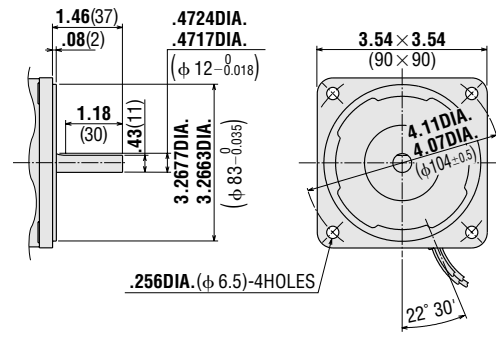

② 5RK60GU-AWTU

5RK60GU-CWTE

Weight (Mass): 6.2 lb.(2.8 kg)

5GU□KA

Weight (Mass): 3.3 lb.(1.5 kg)

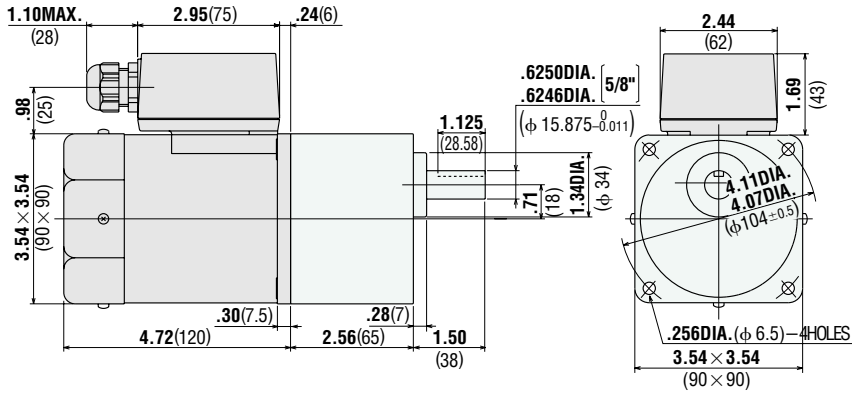

5RK60A-AWTU

5RK60A-CWTE Round Shaft Type

Weight (Mass): 6.2 lb.(2.8 kg)

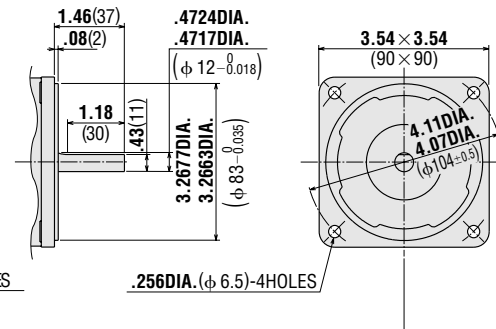

Use cable with the diameter of .24DIA. ($\phi 6$) ~ .47DIA. ($\phi 12$).

Key and Key Slot Scale 1/2

(The key is provided with the gearhead)

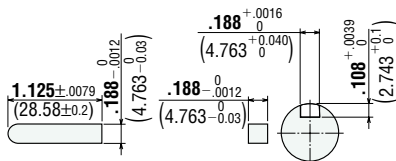

Decimal Gearhead

5GU10XKB Weight (Mass): 1.32 lb.(0.6 kg)

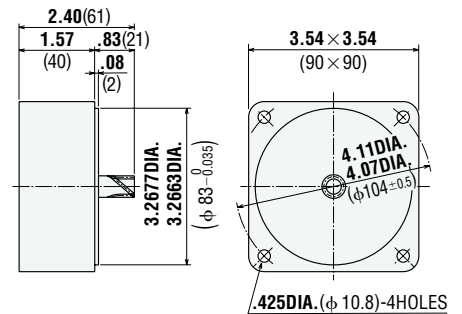

● **Capacitor** (included with the motor)

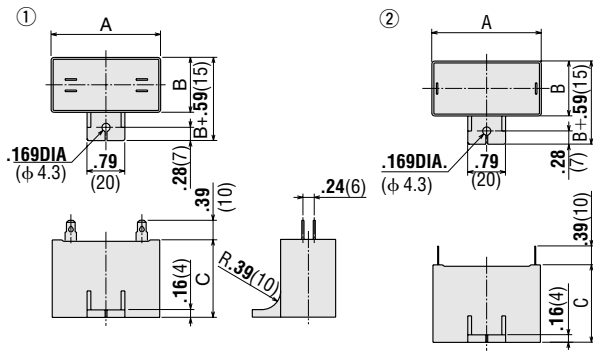

| Motor Model | Capacitor Model | Dimensions inch (mm) | | | Weight (Mass) oz (g) | Dimension No. |
|-----------------------|-----------------|----------------------|--------|------|----------------------|---------------|
| | | A | B | C | | |
| 5RK60GU-AW(T)U | CH200CFAUL | 2.28 | 1.14 | 1.61 | 3.35 (95) | ① |
| 5RK60A-AW(T)U | | (58) | (29) | (41) | | |
| 5RK60GU-CW(T)U | CH50BFAUL | 2.28 | 1.14 | 1.61 | 3.00 (85) | ① |
| 5RK60A-CW(T)U | | (58) | (29) | (41) | | |
| 5RK60GU-AFUL | CH200UL | 2.28 | 0.91 | 1.46 | 2.68 (76) | ② |
| | | (58) | (23.5) | (37) | | |

If you need to order a capacitor without a motor, add "-C" to the capacitor model number shown. A capacitor cap is always included with a capacitor.

■ **Wiring Diagrams** The direction of motor rotation is as viewed from the shaft end of the motor.

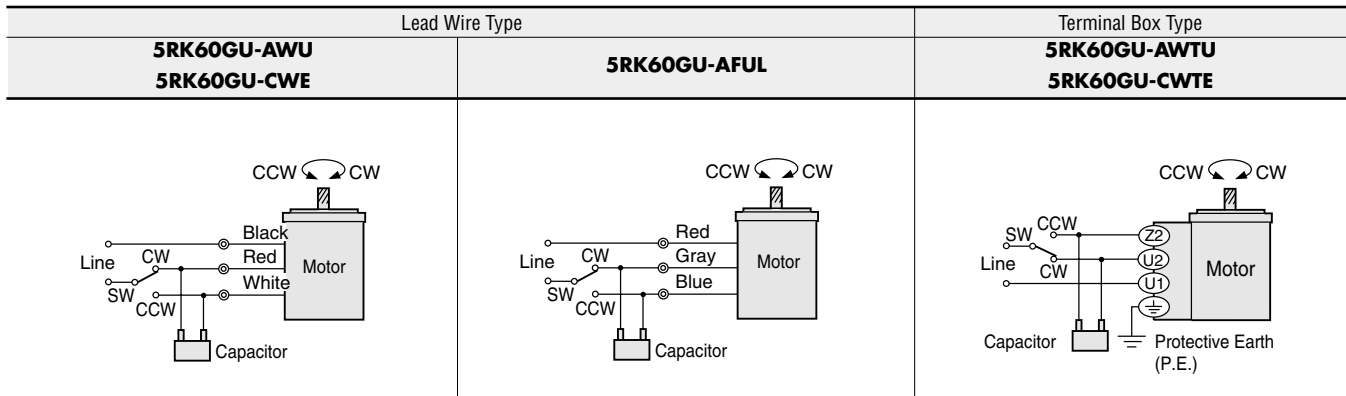

To rotate the motor in a clockwise(CW)direction, flip switch SW to CW.
To rotate it in a counterclockwise(CCW)direction, flip switch SW to CCW.

■ **Right-Angle Gearheads**

The right-angle gearhead provides an output shaft that is at a right angle to the motor's output shaft. See page [A-216] for specifications and other information.

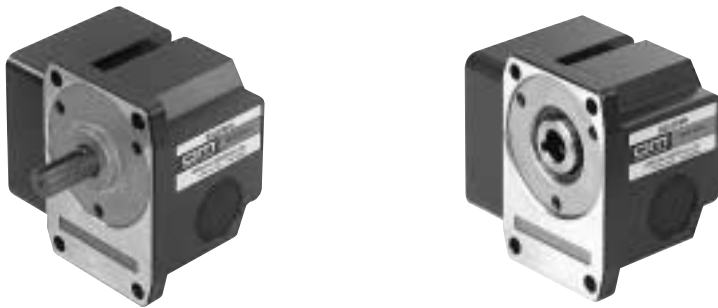

■ **Accessories**

● **Motor Mounting Brackets**

Optional die-cast aluminum mounting brackets are available. They can be used to install motors without gearheads. See page [A-266] for the dimensions.
Model name **SOLSUA**



● **Flexible Couplings**

Optional clamping couplings are available. See page[A-260] for the dimensions.





REVERSIBLE MOTORS

Single-Phase

90W (1/8 HP)

Frame Size 3.54 in.sq. (90mm sq.)



Specifications — 30 Minutes Rating



| Model | | Output Power | Voltage | Frequency | Current | Starting Torque | | Rated Torque | | Rated Speed | Capacitor | |
|-------------------------------------|---------------------------------------|--------------|---------|-----------|---------|-----------------|-------|--------------|-------|-------------|-----------|--------|
| Upper Model Name: Pinion Shaft Type | Lower Model Name(): Round Shaft Type | | | | | oz-in | mN·m | oz-in | mN·m | | | r/min. |
| Lead Wire Type Dimension ① | Terminal Box Type Dimension ② | HP | W | V AC | Hz | A | oz-in | mN·m | oz-in | mN·m | r/min. | μF |
| 5RK90GU-AWU (5RK90A-AWU) | 5RK90GU-AWTU (5RK90A-AWTU) | 1/8 | 90 | 110 | 60 | 1.81 | 81.9 | 590 | 81.2 | 585 | 1500 | 30 |
| | | | | 115 | | | | | | | | |
| 5RK90GU-CWE (5RK90A-CWE) | 5RK90GU-CWTE (5RK90A-CWTE) | | | 220 | 60 | 0.96 | 81.9 | 590 | 84.0 | 605 | 1450 | 7 |
| | | | | 230 | | | | | | | | |
| | | | | 230 | | | | | | | | |
| 5RK90GU-AFUL | — | | | 115 | 60 | 1.60 | 81.9 | 590 | 79.2 | 570 | 1550 | 25 |

- Values shown for starting torque and rated torque are measured for operation without the brake applied.
- The product contains a built-in thermal protector. When a motor overheats for any reason, the thermal protector is opened and the motor stops. When the motor temperature drops, the thermal protector closes and the motor restarts. Be sure to turn the motor off before inspecting.
- The "U" and "E" at the end of the model name indicate that the unit includes a capacitor. These two letters are not listed on the motor nameplate. When the motor is approved under various safety standards, the nameplate is adopted.

Gearmotor—Torque Table

The permissible torque with decimal gearhead with a gear ratio of 10:1 is 174 lb-in (20N·m).

• Right-Angle gearhead may be connected. See page [A-216] for more information.

Single-Phase 115V/230V 60Hz

Unit=Upper values: lb-in/Lower values: N·m

| Model | Speed r/min | Gear Ratio | | | | | | | | | | | | | | | | | | | |
|--------------------------------------|-------------|------------|-----|-----|-----|-----|-----|-----|-----|-----|-----|-----|-----|-----|-----|-----|-----|-----|-----|-----|-----|
| | | 600 | 500 | 360 | 300 | 240 | 200 | 144 | 120 | 100 | 72 | 60 | 50 | 36 | 30 | 24 | 20 | 18 | 15 | 12 | 10 |
| 5RK90GU-AWU 5RK90GU-AWTU / 5GU□KA | 12 | 15 | 21 | 25 | 31 | 37 | 46 | 56 | 67 | 84 | 100 | 121 | 167 | 174 | 174 | 174 | 174 | 174 | 174 | 174 | 174 |
| | 1.4 | 1.7 | 2.4 | 2.8 | 3.6 | 4.3 | 5.3 | 6.4 | 7.7 | 9.7 | 12 | 14 | 19 | 20 | 20 | 20 | 20 | 20 | 20 | 20 | 20 |
| 5RK90GU-CWE 5RK90GU-CWTE / 5GU□KA | 13 | 15 | 21 | 26 | 32 | 38 | 48 | 57 | 69 | 87 | 104 | 125 | 173 | 174 | 174 | 174 | 174 | 174 | 174 | 174 | 174 |
| | 1.5 | 1.8 | 2.5 | 2.9 | 3.7 | 4.4 | 5.5 | 6.6 | 7.9 | 10 | 12 | 14 | 20 | 20 | 20 | 20 | 20 | 20 | 20 | 20 | 20 |
| 5RK90GU-AFUL / 5GU□KA | 12 | 14 | 20 | 24 | 30 | 36 | 45 | 54 | 65 | 82 | 98 | 118 | 163 | 174 | 174 | 174 | 174 | 174 | 174 | 174 | 174 |
| | 1.4 | 1.7 | 2.3 | 2.8 | 3.5 | 4.2 | 5.2 | 6.2 | 7.5 | 9.4 | 11 | 14 | 19 | 20 | 20 | 20 | 20 | 20 | 20 | 20 | 20 |

Single-Phase 230V 50Hz

Unit=Upper values: lb-in/Lower values: N·m

| Model | Speed r/min | Gear Ratio | | | | | | | | | | | | | | | | | | | |
|--------------------------------------|-------------|------------|-----|-----|-----|-----|-----|-----|-----|-----|-----|-----|-----|-----|-----|-----|-----|-----|------|-----|-----|
| | | 500 | 416 | 300 | 250 | 200 | 166 | 120 | 100 | 83 | 60 | 50 | 41 | 30 | 25 | 20 | 16 | 15 | 12.5 | 10 | 8.3 |
| 5RK90GU-CWE 5RK90GU-CWTE / 5GU□KA | 15 | 18 | 26 | 31 | 39 | 46 | 58 | 69 | 83 | 104 | 125 | 150 | 174 | 174 | 174 | 174 | 174 | 174 | 174 | 174 | 174 |
| | 1.8 | 2.1 | 3.0 | 3.5 | 4.4 | 5.3 | 6.7 | 8.0 | 9.6 | 12 | 14 | 17 | 20 | 20 | 20 | 20 | 20 | 20 | 20 | 20 | 20 |

- Gearheads are sold separately.
- Enter the gear ratio in the box (□) within the model number. A colored background indicates gear shaft rotation in the same direction as the motor shaft; a white background indicates rotation in the opposite direction.
- The speed is calculated by dividing the motor's synchronous speed (50 Hz: 1500 r/min, 60 Hz: 1800 r/min) by the gear ratio. The actual speed is 2 ~ 20% less than the displayed value, depending on the size of the load.

■ Dimensions Scale 1/4, Unit = inch (mm)

① 5RK90GU-AWU 5RK90GU-CWE 5RK90GU-AFUL

Weight (Mass): 7.1 lb.(3.2 kg)

5GU□KA

Weight (Mass): 3.3 lb.(1.5 kg)

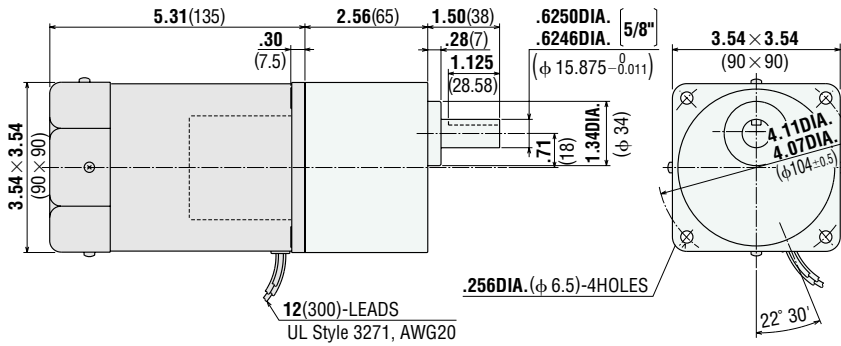

5RK90A-AWU

5RK90A-CWE Round Shaft Type

Weight (Mass): 7.1 lb.(3.2 kg)

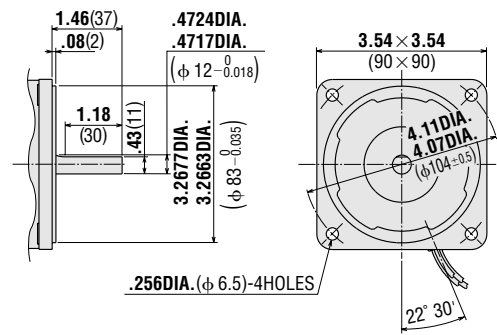

② 5RK90GU-AWTU 5RK90GU-CWTE

Weight (Mass): 7.3 lb.(3.3 kg)

5GU□KA

Weight (Mass): 3.3 lb.(1.5 kg)

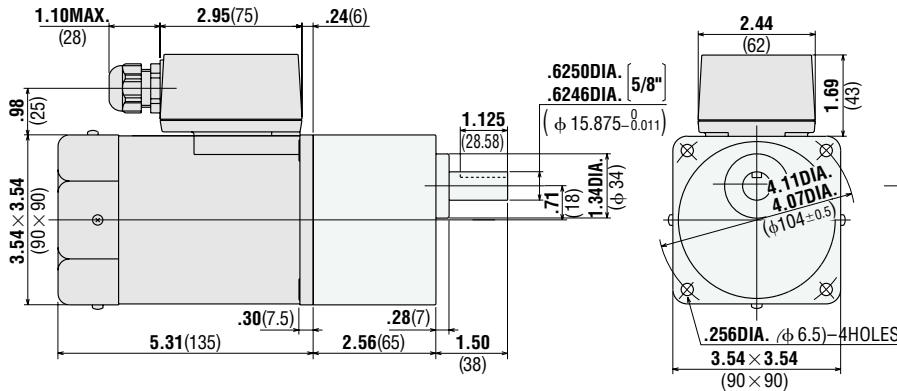

5RK90A-AWTU

5RK90A-CWTE Round Shaft Type

Weight (Mass): 7.3 lb.(3.3 kg)

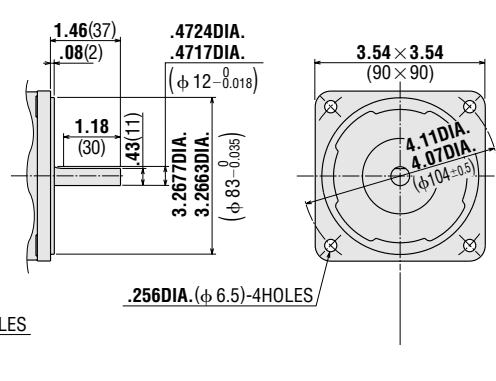

Use cabtyre cable with the diameter of .24DIA.(φ 6)~.47DIA.(φ 12).

● Key and Key Slot Scale 1/2

(The key is provided with the gearhead)

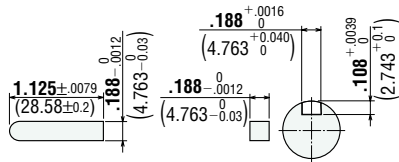

● Decimal Gearhead

5GU10XKB

Weight (Mass): 1.32 lb.(0.6 kg)

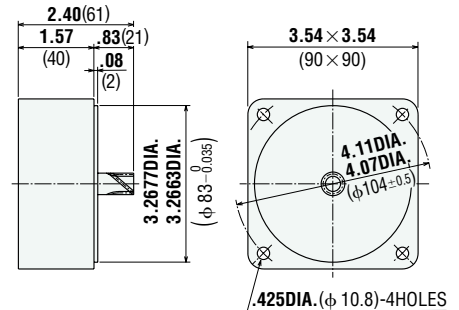

● **Capacitor** (included with the motor)

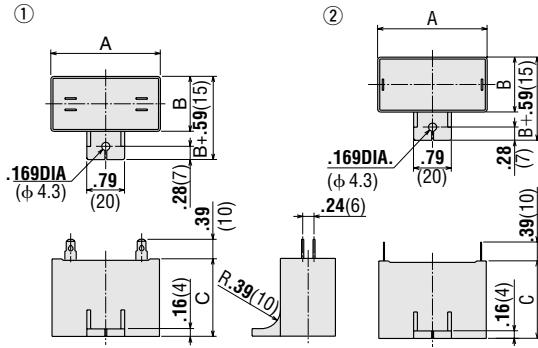

| Motor Model | Capacitor Model | Dimensions inch(mm) | | | Weight (Mass) oz (g) | Dimension No. |
|-----------------------|-----------------|---------------------|------|------|----------------------|---------------|
| | | A | B | C | | |
| 5RK90GU-AW(T)U | CH300CFAUL | 2.28 | 1.38 | 1.97 | 4.94 (140) | ① |
| 5RK90A-AW(T)U | | (58) | (35) | (50) | | |
| 5RK90GU-CW(T)E | CH70BFAUL | 2.28 | 1.38 | 1.97 | 4.59 (130) | ① |
| 5RK90A-CW(T)E | | (58) | (35) | (50) | | |
| 5RK90GU-AFUL | CH250UL | 2.28 | 1.14 | 1.61 | 3.42 (97) | ② |

If you need to order a capacitor without a motor, add "-C" to the capacitor model number shown. A capacitor cap is always included with a capacitor.

■ **Wiring Diagrams** The direction of motor rotation is as viewed from the shaft end of the motor.

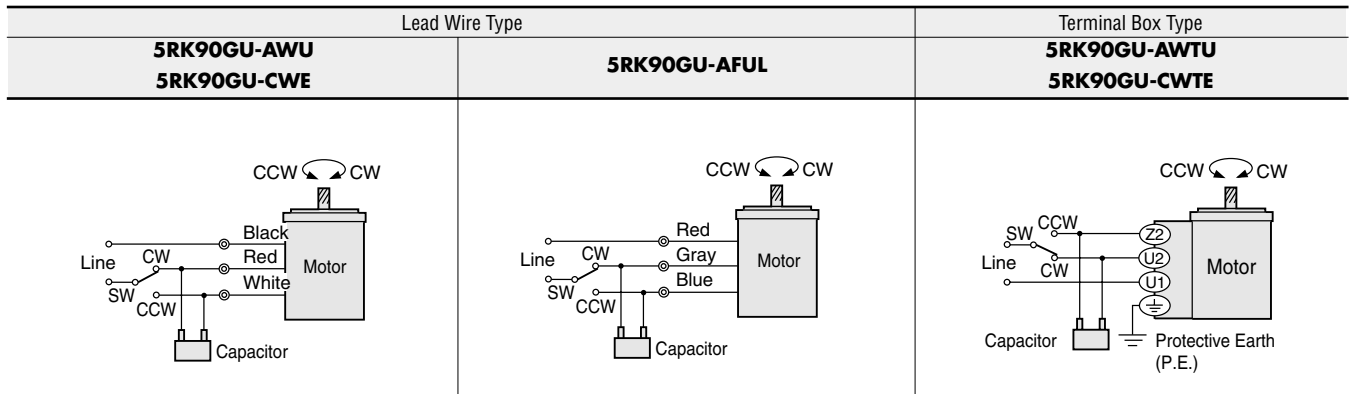

To rotate the motor in a clockwise(CW)direction, flip switch SW to CW.
 To rotate it in a counterclockwise(CCW)direction, flip switch SW to CCW.

■ **Right-Angle Gearheads**

The right-angle gearhead provides an output shaft that is at a right angle to the motor's output shaft. See page [A-216] for specifications and other information.

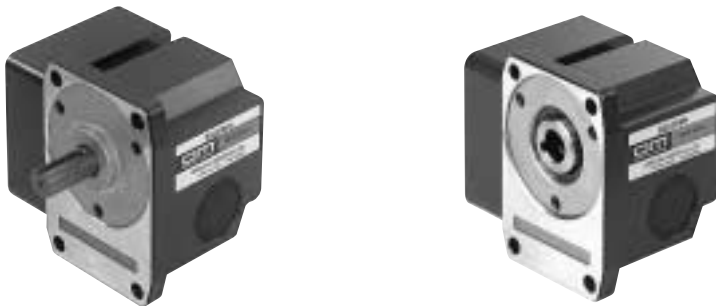

■ **Accessories**

● **Motor Mounting Brackets**

Optional die-cast aluminum mounting brackets are available. They can be used to install motors without gearheads. See page [A-266] for the dimensions.
 Model name **SOL5UA**



● **Flexible Couplings**

Optional clamping couplings are available. See page[A-260] for the dimensions.



SYNCHRONOUS MOTORS

■ Features

Synchronous motors provide rotation at a fixed speed in synchronization with the frequency of the power source, regardless of fluctuation of the load or line voltage. Synchronous speed is 1800r/min at 60Hz.



Gearheads shown in the photograph are sold separately.



■ Specifications — Continuous Rating



| Model | | Output Power | | Voltage | Frequency | Current | Starting Torque | | Rated Torque | | Rated Speed | Capacitor | |
|--------------------|--------------------|--------------|----|---------|-----------|---------|-----------------|------|--------------|------|-------------|-----------|-----|
| Pinion Shaft Type | Round Shaft Type | HP | W | V AC | Hz | A | oz-in | mN·m | oz-in | mN·m | r/min | μF | VAC |
| 2SK4GN-AUL | 2SK4A-AULA | 1/187 | 4 | 115 | 60 | 0.24 | 3.1 | 22 | 3.1 | 22 | 1800 | 1.0 | 400 |
| 3SK10GN-AUL | 3SK10A-AULA | 1/75 | 10 | 115 | 60 | 0.35 | 6.9 | 50 | 7.6 | 55 | 1800 | 1.5 | 400 |
| 4SK15GN-AUL | 4SK15A-AULA | 1/50 | 15 | 115 | 60 | 0.50 | 7.6 | 55 | 11.2 | 81 | 1800 | 1.5 | 400 |
| 5SK25GN-AUL | 5SK25A-AULA | 1/30 | 25 | 115 | 60 | 0.75 | 11.8 | 85 | 18.7 | 135 | 1800 | 3.0 | 400 |

● **2SK** type motors are impedance protected.

● **3SK, 4SK** and **5SK** type motors contain a built-in thermal protector. If a motor overheats for any reason, the thermal protector is opened and the motor stops. When the motor temperature drops, the thermal protector closes and the motor restarts. Be sure to turn the motor off before inspecting.

■ General Specifications

These specifications apply to all synchronous motors.

| Item | Specifications |
|---------------------------|---|
| Insulation Resistance | 100M ohms or more when 500V DC is applied between the windings and the frame after rated motor operation under normal ambient temperature and humidity. |
| Dielectric Strength | Sufficient to withstand 1.5kV at 50Hz and 60Hz applied between the windings and the frame after rated motor operation under normal ambient temperature and humidity. |
| Temperature Rise | 135°F (75°C) or less measured by the resistance change method after the temperature of the coil has stabilized under normal operation at the rated voltage and frequency. |
| Insulation Class | UL•CSA Standard Class A, EN60950 Standard Class E. |
| Ambient Temperature Range | 14°F ~ 104°F (-10°C ~ +40°C) |
| Ambient Humidity | 85% maximum (noncondensing) |

■ Gearmotor — Torque Table

- The permissible torque with decimal gearhead with a gear ratio of 10 is : **2GN** □ **K** : 26 lb-in / 3N·m **3GN** □ **K** : 43 lb-in / 5N·m
4GN □ **K** : 69 lb-in / 8N·m (for 1/25~1/36 : 52 lb-in / 6N·m)
5GN □ **K** : 87 lb-in / 10N·m

Unit = Upper values: lb-in / Lower values: N·m

| Model | Speed r/min | 600 | 500 | 360 | 300 | 240 | 200 | 144 | 120 | 100 | 72 | 60 | 50 | 36 | 30 | 24 | 20 | 18 | 15 | 12 | 10 |
|--------------------------------------|-------------|----------|------------|----------|----------|------------|----------|-------------|-----------|-----------|-----------|-----------|-----------|-----------|-----------|-----------|-----------|------------|------------|------------|------------|
| | Gear Ratio | 3 | 3.6 | 5 | 6 | 7.5 | 9 | 12.5 | 15 | 18 | 25 | 30 | 36 | 50 | 60 | 75 | 90 | 100 | 120 | 150 | 180 |
| 2SK4GN-AUL / 2GN □ KA | 0.47 | 0.56 | 0.78 | 0.94 | 1.2 | 1.4 | 2.0 | 2.4 | 2.8 | 3.5 | 4.2 | 5.1 | 6.4 | 7.7 | 9.6 | 12 | 13 | 15 | 19 | 23 | |
| | 0.053 | 0.064 | 0.089 | 0.11 | 0.13 | 0.16 | 0.22 | 0.27 | 0.32 | 0.40 | 0.48 | 0.58 | 0.73 | 0.87 | 1.1 | 1.3 | 1.5 | 1.7 | 2.2 | 2.6 | |
| 3SK10GN-AUL / 3GN □ KA | 1.2 | 1.4 | 1.9 | 2.3 | 2.9 | 3.5 | 4.8 | 5.8 | 6.9 | 8.7 | 10 | 12 | 16 | 19 | 24 | 28 | 31 | 38 | 43 | 43 | |
| | 0.13 | 0.16 | 0.22 | 0.27 | 0.33 | 0.40 | 0.56 | 0.67 | 0.80 | 1.0 | 1.2 | 1.4 | 1.8 | 2.2 | 2.7 | 3.3 | 3.6 | 4.4 | 5 | 5 | |
| 4SK15GN-AUL / 4GN □ KA | 1.7 | 2.0 | 2.8 | 3.4 | 4.3 | 5.1 | 7.1 | 8.5 | 10 | 13 | 15 | 18 | 23 | 28 | 35 | 42 | 46 | 55 | 69 | 69 | |
| | 0.20 | 0.24 | 0.33 | 0.39 | 0.49 | 0.59 | 0.82 | 0.98 | 1.2 | 1.5 | 1.8 | 2.1 | 2.7 | 3.2 | 4.0 | 4.8 | 5.3 | 6.4 | 8 | 8 | |
| 5SK25GN-AUL / 5GN □ KA | 2.8 | 3.4 | 4.7 | 5.7 | 7.1 | 8.5 | 12 | 14 | 17 | 21 | 26 | 31 | 39 | 46 | 58 | 69 | 77 | 87 | 87 | 87 | |
| | 0.33 | 0.39 | 0.55 | 0.66 | 0.82 | 0.98 | 1.4 | 1.6 | 2.0 | 2.5 | 3.0 | 3.5 | 4.5 | 5.3 | 6.7 | 8.0 | 8.9 | 10 | 10 | 10 | |

- Gearheads are sold separately.
- Enter the gear ratio in the box within the model number. A colored background indicates gear shaft rotation in the same direction as the motor shaft; a white background indicates rotation in the opposite direction.
- The speed is calculated by dividing the motor's speed (60 Hz: 1800 r/min) by the gear ratio.

■ Wiring Diagrams

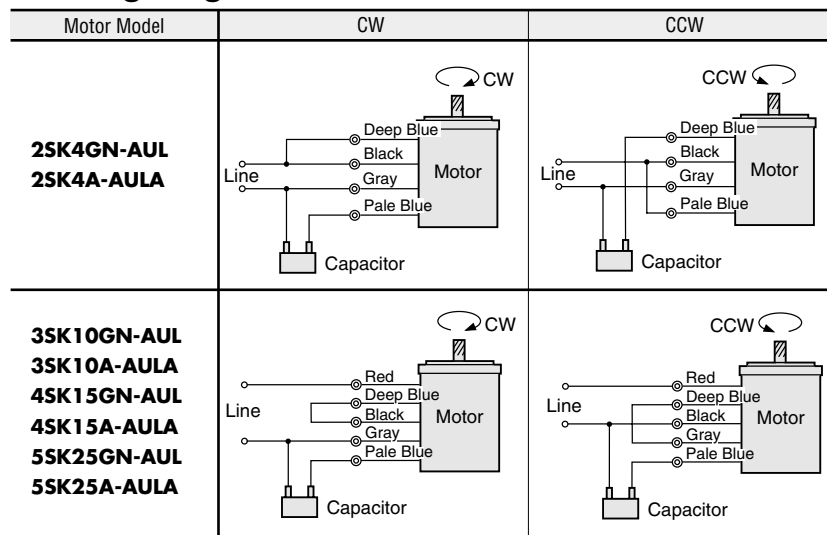

The direction of motor rotation is as viewed from the shaft end of the motor.

Change the direction of motor rotation only after bringing the motor to a stop. If an attempt is made to change the direction of rotation while the motor is rotating, the motor may ignore the reversing command or change its direction of rotation after some delay.

■ Dimensions Scale 1/4, Unit = inch (mm)

2SK4GN-AUL

Weight (Mass): 1.5 lb.(0.7 kg)

2GN□KA

Weight (Mass): 0.88 lb.(0.4 kg)

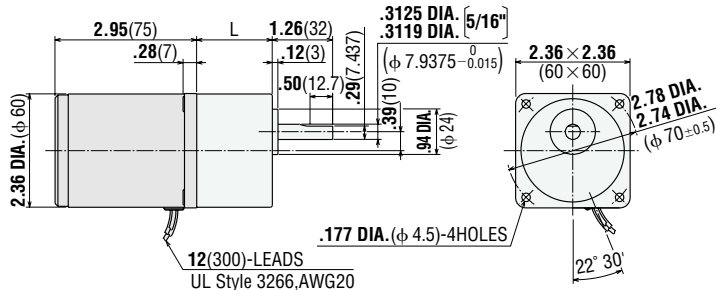

L = 1.18 (30) **2GN3KA~18KA**
L = 1.57 (40) **2GN25KA~180KA**

2SK4A-AULA Round Shaft Type

Weight (Mass): 1.5 lb.(0.7 kg)

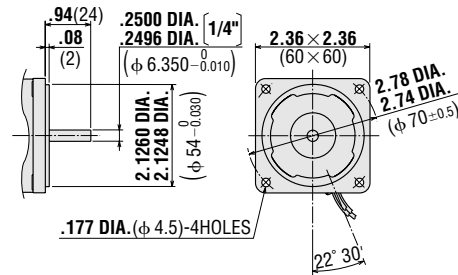

3SK10GN-AUL

Weight (Mass): 2.4 lb.(1.1 kg)

3GN□KA

Weight (Mass): 1.21 lb.(0.55 kg)

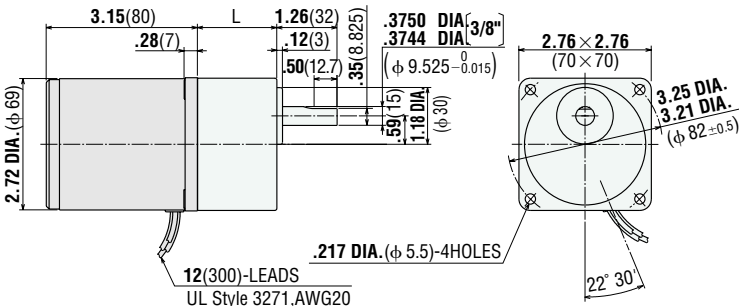

L = 1.26 (32) **3GN3KA~18KA**
L = 1.65 (42) **3GN25KA~180KA**

3SK10A-AULA Round Shaft Type

Weight (Mass): 2.4 lb.(1.1 kg)

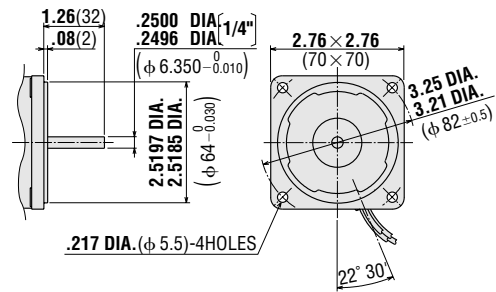

4SK15GN-AUL

Weight (Mass): 3.3 lb.(1.5 kg)

4GN□KA

Weight (Mass): 1.43 lb.(0.65 kg)

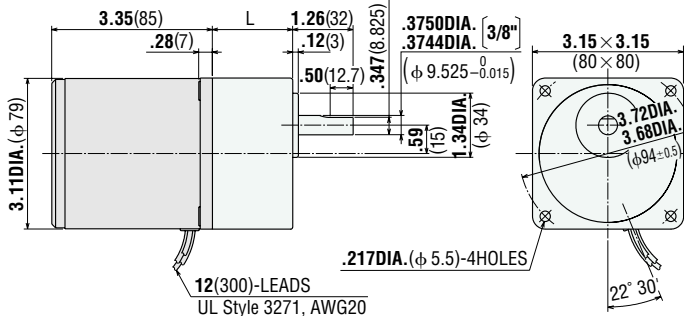

L = 1.26 (32) **4GN3KA~18KA**
L = 1.67 (42.5) **4GN25KA~180KA**

4SK15A-AULA Round Shaft Type

Weight (Mass): 3.3 lb.(1.5 kg)

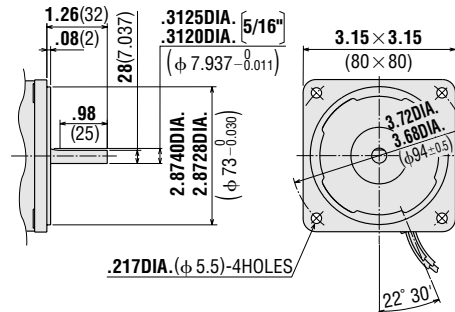

● Decimal Gearhead

2GN10XK Weight (Mass): 0.44 lb.(0.2 kg)

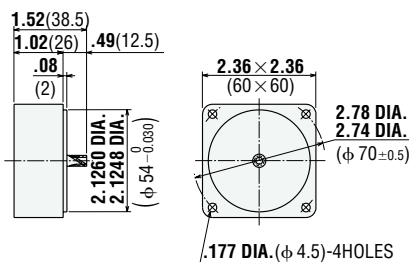

3GN10XK Weight (Mass): 0.66 lb.(0.3 kg)

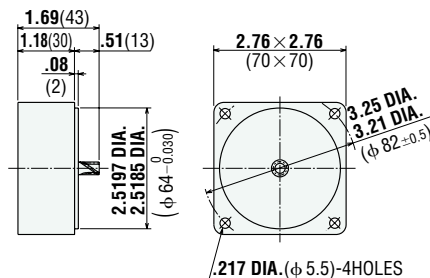

4GN10XK Weight (Mass): 0.88 lb.(0.4 kg)

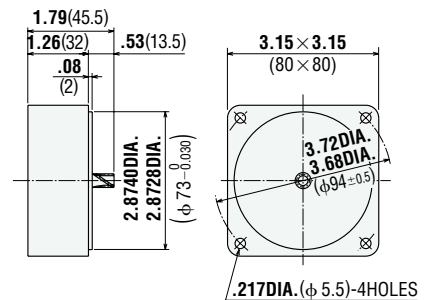

5SK25GN-AUL

Weight (Mass): 5.5 lb.(2.5 kg)

5GN□KA

Weight (Mass): 3.31 lb.(1.5 kg)

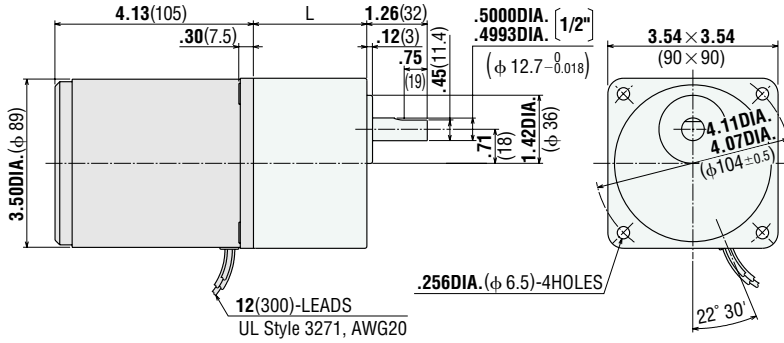

5SK25A-AULA Round Shaft Type

Weight (Mass): 5.5 lb.(2.5 kg)

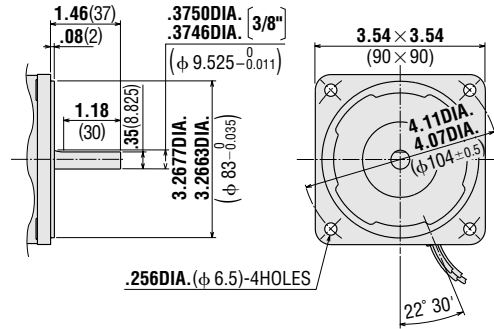

L = 1.65 (42) **5GN3KA~18KA**
L = 2.36 (60) **5GN25KA~180KA**

Decimal Gearhead

5GN10XK Weight (Mass): 1.32 lb.(0.6 kg)

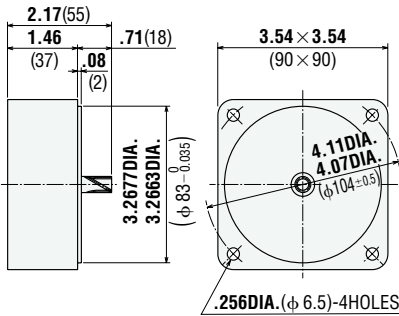

Capacitor (included with the motor)

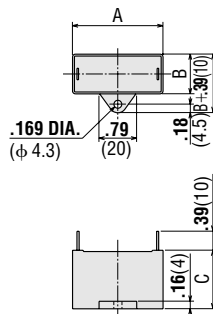

| Motor Model | Capacitor Model | Dimensions inch (mm) | | | Weight oz (g) |
|--------------------|-----------------|----------------------|------|------|---------------|
| | | A | B | C | |
| 2SK4GN-AUL | CH10BUL | 1.22 | .67 | 1.06 | 0.8 23 |
| 2SK4A-AULA | | (31) | (17) | (27) | |
| 3SK10GN-AUL | CH15BUL | 1.46 | .71 | 1.06 | 1.0 27 |
| 3SK10A-AULA | | (37) | (18) | (27) | |
| 4SK15GN-AUL | CH15BUL | 1.46 | .71 | 1.06 | 1.0 27 |
| 4SK15A-AULA | | (37) | (18) | (27) | |
| 5SK25GN-AUL | CH30BUL | 2.28 | .83 | 1.22 | 1.4 39 |
| 5SK25A-AULA | | (48) | (21) | (31) | |

Capacitor cap is provided with the capacitor.

Right-Angle Gearhead

The right-angle gearhead provides an output shaft at a right angle to the motor's output shaft. See page [A-216] for specifications and other information. (Available with **4GN□R□**, **5GN□R□** type only)

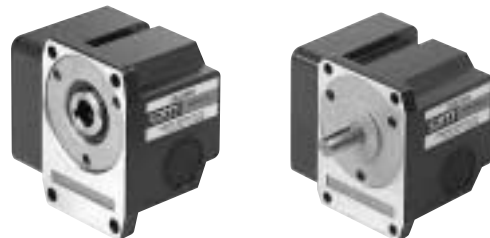

TORQUE MOTORS

Torque motors are specially designed to provide high starting torque and operate over a wide speed range. They also provide stable operation in the low speed range or under a locked rotor condition.



Gearhead shown in the photograph is sold separately.



■ Features

● Speed can be varied over a wide range

The motor torque is approximately proportional to the square of the voltage, allowing easy speed control simply by changing the voltage of the power supply.

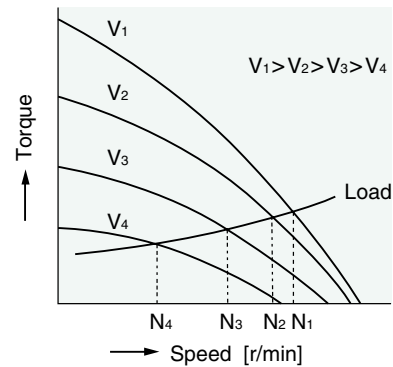

● Suitable for winding applications

In an application where an object is released continuously at a constant speed and wound up with constant tension, the torque must be doubled and the speed must be halved if the diameter of the winding spool is doubled. Since torque motors provide high torque at low speed, they are suitable for such operations.

Constant Tension Wind Up

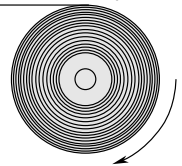

● Locked rotor operation is available

Unlike other standard AC motors, torque motors are designed to provide a stable torque even under stall condition or at very low speed (nearly stalling). They are suitable for pushing applications that require static torque. The motors can operate continuously at 60V. When used at voltages than 60V, the motors are rated for limited duty. The motor has a 5 minute rating at 115V.

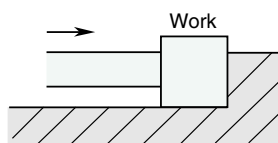

Note: When using a motor in locked rotor condition, the output torque becomes very large. Do not exceed the permissible torque of the gearhead.

● Used as a brake

By using the motor in the braking region of the speed-torque characteristics, it can be made to serve as a brake. Constant tension operation can be achieved by applying DC voltage.

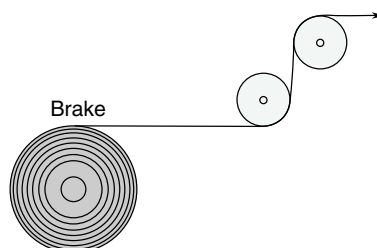

■ Characteristics of Torque Motors

The speed-torque characteristics of torque motors are different from those of induction motors or reversible motors. As the following graph shows, they have special torque characteristics (torque is highest at zero speed and decreases steadily with increasing speed), so they can provide stable operation through the entire speed range, from starting to no load speed. The torque generated when reversing the motor is a positive torque in the same direction as the rotational magnetic field; this torque is large. When the motor is locked by the load and the motor is rotated opposite the desired direction, this torque acts as a force (braking force) to inhibit the motor from rotating backwards.

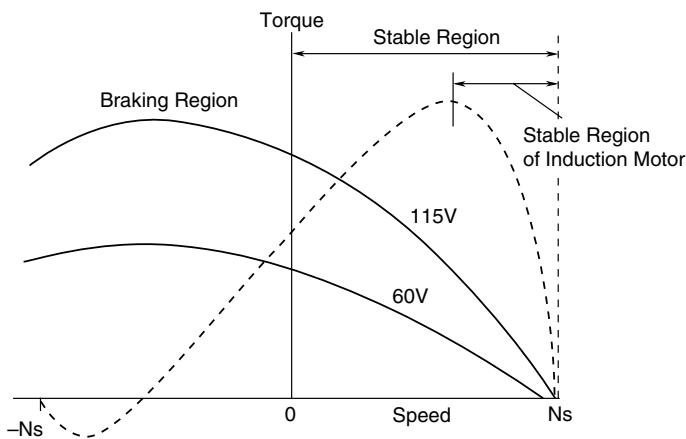

The torque generated by the torque motor changes approximately proportionally to the square of the voltage. When the voltage supplied to the motor is changed, speed-torque characteristic curves shift to that of the corresponding voltage. When the voltage is changed to 115, 80 and 60V while the load torque is T_0 , the motor rotates at the speeds N_1 , N_2 and N_3 respectively. Thus the speed can be changed easily by varying the voltage.

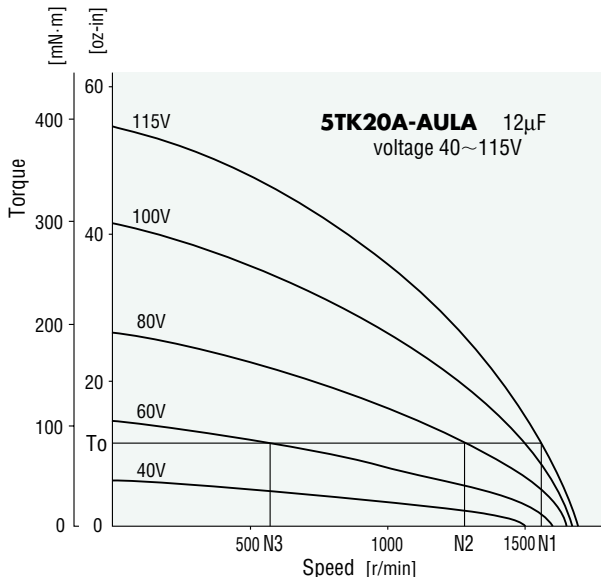

When choosing a torque motor, first determine the required torque and speed. Then select a motor using the speed-torque characteristic curves to determine whether the motor should be operated under continuous duty or limited duty. When used under locked rotor conditions, only the torque factor is considered. The temperature rise of the motor may cause a problem during continuous operation. In this case, choose a motor with an output power large enough for continuous operation and adjust the voltage to control the torque and speed.

■ Voltage Control of Torque Motors

Phase Control Method Using a Triac

The method most commonly used to control voltage is phase control using a triac. As shown in Fig. 1, by changing the phase angle "alpha" at which the triac switches, the input voltage is controlled as represented by the Phase Angle areas of the graph.

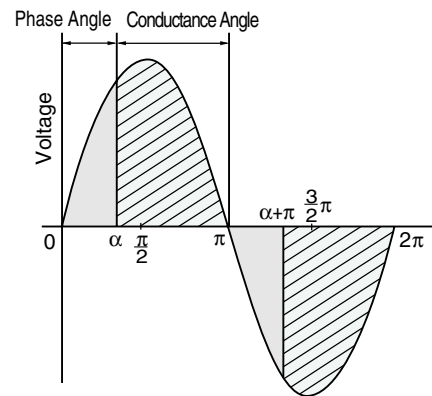

Fig.1 Phase Control

TORQUE MOTORS

Single-Phase

8w · 12w · 23w

Frame Size

2.76"sq.(□70mm), 3.15"sq.(□80mm), 3.54"sq.(□90mm)



Specifications

| Model | | Rating at Locked Rotor | Voltage V AC | Frequency Hz | Starting Torque oz-in | Starting Torque mN·m | Output Power | | At max. output power | | | | Capacitor μF | |
|--------------------|--------------------|------------------------|--------------|--------------|-----------------------|----------------------|--------------|-----|----------------------|--------------|-------------|-----------|--------------|---------|
| Pinion Shaft Type | Round Shaft Type | | | | | | HP | W | Speed r/min | Torque oz-in | Torque mN·m | Current A | | Input W |
| 3TK6GN-AUL | 3TK6A-AULA | 5 minutes | 115 | 60 | 20.8 | 150 | 1/93 | 8 | 900 | 12.1 | 87 | 0.62 | 67 | 8.0 |
| | | Continuous | 60 | 60 | 6.2 | 45 | 1/300 | 2.5 | 3.7 | 27 | 0.34 | 20 | | |
| 4TK10GN-AUL | 4TK10A-AULA | 5 minutes | 115 | 60 | 27.1 | 195 | 1/62 | 12 | 900 | 18.1 | 130 | 0.66 | 70 | 8.0 |
| | | Continuous | 60 | 60 | 6.9 | 50 | 1/266 | 2.8 | 4.4 | 31 | 0.32 | 19 | | |
| 5TK20GN-AUL | 5TK20A-AULA | 5 minutes | 115 | 60 | 48.6 | 350 | 1/32 | 23 | 900 | 34.7 | 250 | 1.0 | 110 | 12.0 |
| | | Continuous | 60 | 60 | 12.5 | 90 | 1/124 | 6 | 9.0 | 65 | 0.49 | 29 | | |

• The product contains a built-in thermal protector. If a motor overheats for any reason, the thermal protector is opened and the motor stops. When the motor temperature drops, the thermal protector closes and the motor restarts. Be sure to turn the motor off before inspecting.

General Specifications

| Item | Specifications |
|---------------------------|---|
| Insulation Resistance | 100M ohms or more when 500V DC is applied between the windings and the frame after rated motor operation under normal ambient temperature and humidity. |
| Dielectric Strength | Sufficient to withstand 1.5kV at 50Hz and 60Hz applied between the windings and the frame after rated motor operation under normal ambient temperature and humidity. |
| Temperature Rise | 135°F (75°C) or less measured by the resistance change method after the temperature of the coil has stabilized under normal operation at the rated voltage and frequency. |
| Insulation Class | UL-CSA Standard Class A, EN60950 Standard Class E. |
| Ambient Temperature Range | 14°F ~ 104°F (-10°C ~ +40°C) |
| Ambient Humidity | 85% maximum (noncondensing) |

Permissible Torque When Gearhead Is Attached

Due to the special characteristics, torque motors can be operated over a wide speed range, from locked rotor condition to the maximum speed. The permissible torque when a gearhead and a decimal gearhead are directly connected (T_G) can be calculated according to the following formula using the speed and torque determined from the speed-torque characteristics.

$$T_G = T_M \times i \times \eta$$

T_M : Rated torque of motor

i : Gear ratio

η : Gearhead efficiency (refer to the table on the right.)

The output torque of the gearmotor must be lower than the maximum permissible torque specified in the graph on page [A-21]. The speed of the gearmotor output shaft (N_G) is calculated as follows:

$$N_G = \frac{N_M}{i}$$

N_M : Rated speed of motor

i : Gear ratio

3GN□KA, 4GN□KA, 5GN□KA

| Gear Ratio | Gearhead Efficiency |
|---|---------------------|
| 3, 3.6, 5, 6, 7.5, 9, 12.5, 15, 18 | 81% |
| 25, 30, 36 | 73% |
| 50, 60, 75, 90, 100, 120, 150, 180 | 66% |

Right-Angle Gearhead

| Model | Gear Ratio | Gearhead Efficiency |
|---------------------------------|---|---------------------|
| 4GN□RAA (Solid shaft) | 3,6,6,9 | 50% (50%) |
| | 15,18,30,36 | 60% (54%) |
| | 60,90,120,180 | |
| 5GN□RAA (Solid shaft) | 3,3.6,5,6,7.5,9,12.5,15,18,25,30 | 68% (60%) |
| | 36,50,60,75,90,100,120,150,180 | 60% (54%) |
| | 3,6,6 | 40% (40%) |
| 4GN□RH (Hollow shaft) | 9 | 50% (50%) |
| | 15,18,30,36 | 60% (54%) |
| | 60,90,120,180 | |
| 5GN□RH (Hollow shaft) | 3,6,6 | 50% (50%) |
| | 9,15,18 | 68% (60%) |
| | 30,36,60,90,120,180 | 60% (54%) |

- Enter the gear ratio in the box within the model number. The numbers in parenthesis indicate the efficiency at starting condition.
- Gearheads are sold separately.

■ Wiring Diagram

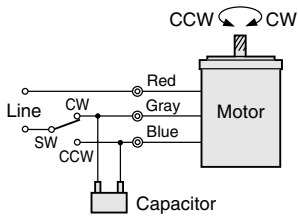

To rotate the motor in a clockwise (CW) direction, flip switch SW to CW.
To rotate it in a counterclockwise (CCW) direction, flip this switch to CCW.

The direction of motor rotation is as viewed from the front shaft end of the motor.

■ Speed – Torque Characteristics

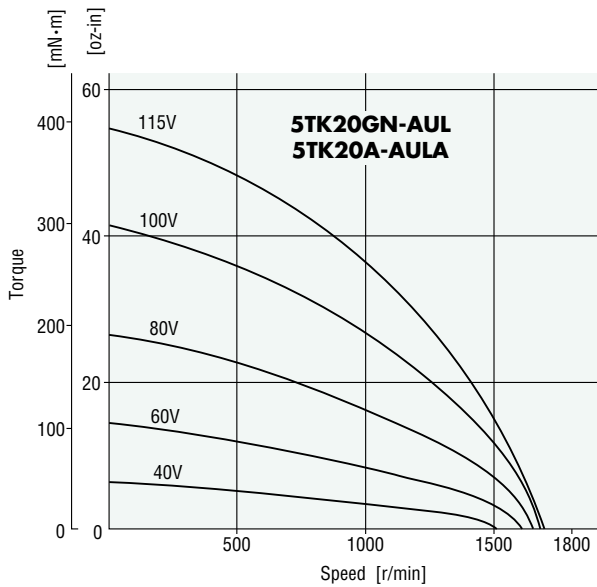
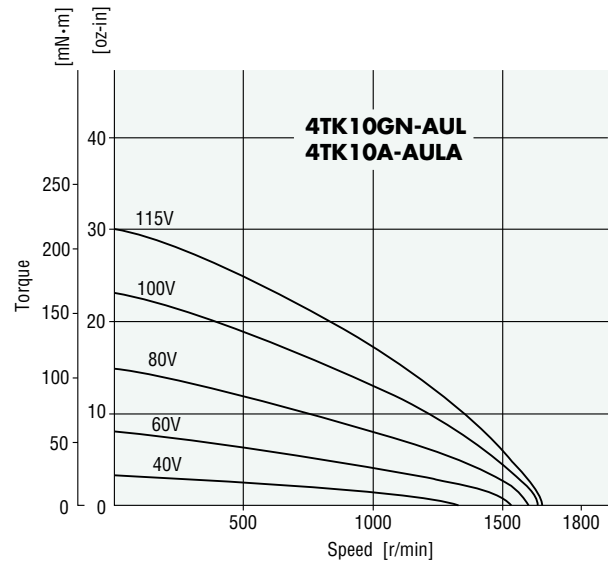
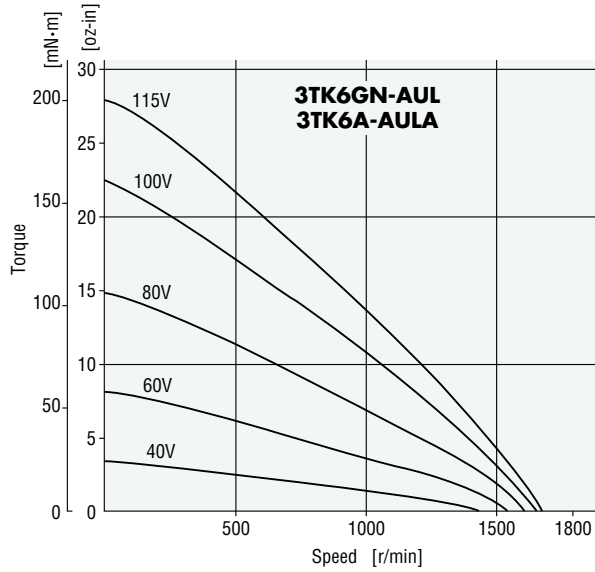

■ Dimensions Scale 1/4, Unit = inch (mm)

3TK6GN-AUL

Weight (Mass): 2.4 lb.(1.1 kg)

3GN□KA

Weight (Mass): 1.21 lb.(0.55 kg)

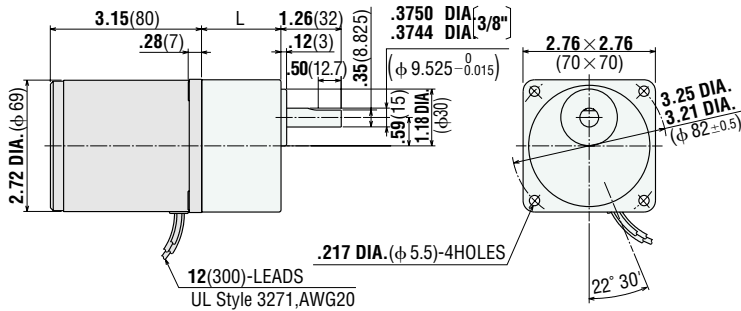

UL Style 3271,AWG20
 L = 1.26 (32) **3GN3KA~18KA**
 L = 1.65 (42) **3GN25KA~180KA**

● Decimal Gearhead

3GN10XK

Weight (Mass): 0.66 lb.(0.3 kg)

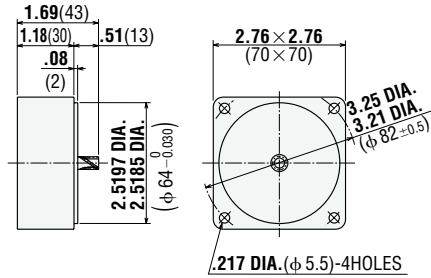
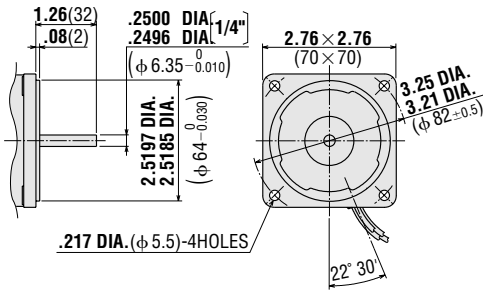

4TK10GN-AUL

Weight (Mass): 3.3 lb.(1.5 kg)

4GN□KA

Weight (Mass): 1.43 lb.(0.65 kg)

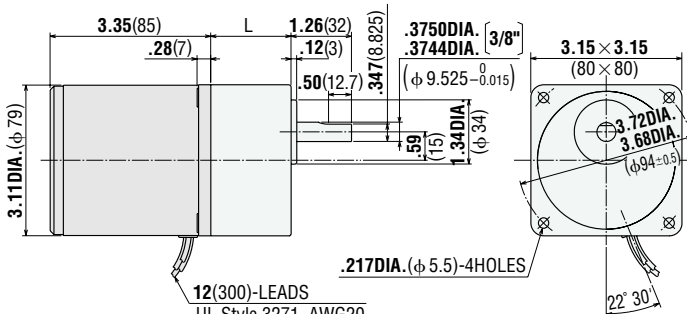

UL Style 3271, AWG20
 L = 1.26 (32) **4GN3KA~18KA**
 L = 1.67 (42.5) **4GN25KA~180KA**

● Decimal Gearhead

4GN10XK

Weight (Mass): 0.88 lb.(0.4 kg)

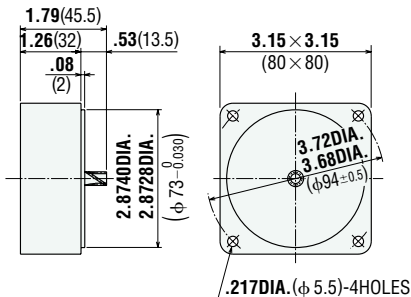
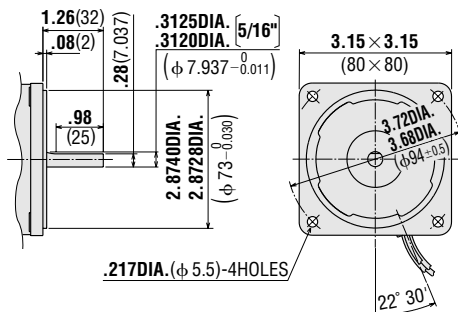

5TK20GN-AUL

Weight (Mass): 5.5 lb.(2.5 kg)

5GN□KA

Weight (Mass): 3.31 lb.(1.5 kg)

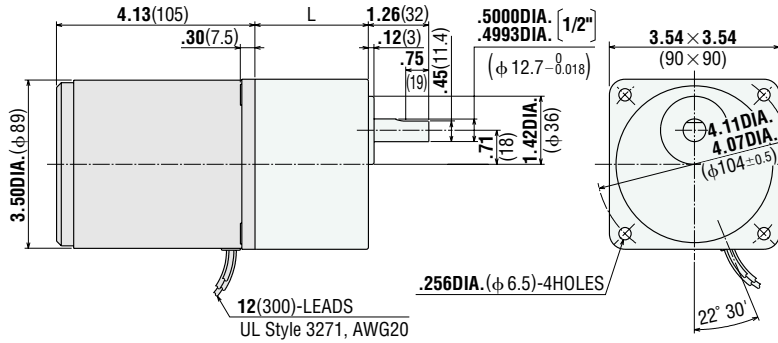

L = 1.65 (42) **5GN3KA~18KA**
 L = 2.36 (60) **5GN25KA~180KA**

5TK20A-AULA

Round Shaft Type Weight (Mass): 5.5 lb.(2.5 kg)

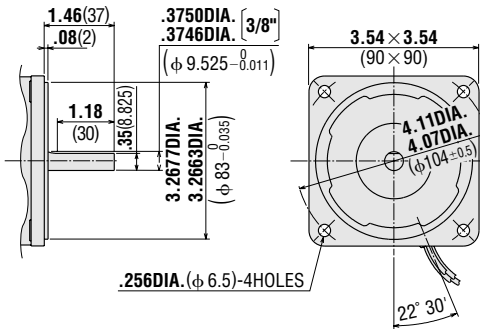

Decimal Gearhead

5GN10XK

Weight (Mass): 1.32 lb.(0.6 kg)

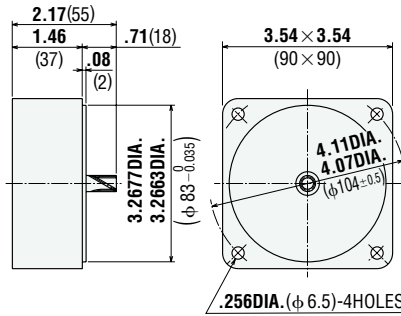

Capacitor (included with the motor)

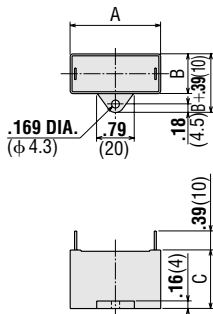

| Motor Model | Capacitor Model | Dimensions inch (mm) | | | Weight oz (g) |
|--------------------|-----------------|----------------------|------|------|---------------|
| | | A | B | C | |
| 3TK6GN-AUL | CH80UL | 1.50 | .83 | 1.22 | 1.23 35 |
| 3TK6A-AULA | | (38) | (21) | (31) | |
| 4TK10GN-AUL | CH80UL | 1.50 | .83 | 1.22 | 1.23 35 |
| 4TK10A-AULA | | (38) | (21) | (31) | |
| 5TK20GN-AUL | CH120CUL | 2.28 | .83 | 1.22 | 1.76 50 |
| 5TK20A-AULA | | (58) | (21) | (31) | |

Capacitor cap is provided with the capacitor.

Right-Angle Gearhead

The right-angle gearhead provides an output shaft at a right angle to the motor's output shaft. See page [A-216] for specifications and other information. (Available with **4GN□R□** **5GN□R□** type only)

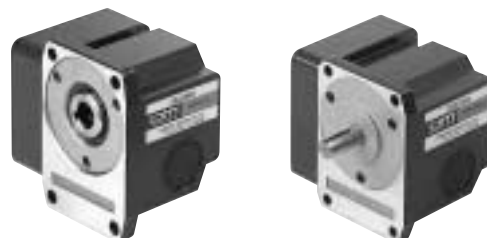

ORIENTAL MOTOR GENERAL CATALOG

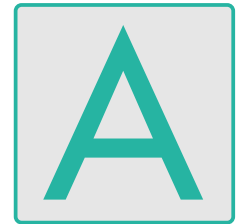

Speed Control Motors

| | |
|---------------------------------|-------|
| Product Line and Features | A-114 |
| Motor Selection..... | A-116 |
| FBL II Series..... | A-120 |
| HBL Series | A-132 |
| SC Series | A-142 |
| US Series | A-156 |
| Component Type | A-170 |

Product Line and Features of Speed Control Motors

Speed control motors can easily set and adjust the speed with the use of a potentiometer. The control system consists of a speed feedback system, a motor, a speed control pack (or a driver) and a potentiometer.

The motor for the speed control system may be either a brushless DC motor or a standard AC motor.

■ Features

- **High speed up to 3000 r/min (FBLII series) or 2000 r/min (HBL series)**

With standard AC speed control motors, speed is usually limited to 1600r/min at 60Hz.

- **Constant torque**

These DC brushless motor systems offer constant torque over the entire speed range.

■ Electronic-Input Control

Most speed control motors use power relays to control the motor and control pack. However, as the control pattern becomes more complex, the relays cannot follow the sequence and also require maintenance.

The electronic-input type, on the other hand, uses either a photocoupler or a C-MOS type input circuit. Requiring no external relays, the motor can be connected directly to a programmable controller (PLC), featuring the following advantages.

- **Maintenance Free**

As the motor requires no power relays, there is no need for periodic service or replacement of relays. This makes the machine highly reliable.

- **Easy connection**

With no power relays, connection is easy, and the time required to set up the motor is greatly reduced. Moreover, they can make the time needed for circuit design shorter than that required for setting a relay sequence.

Maintenance-free speed control motors that can be operated directly from a programmable controller (PLC).

FBLII Series A-120 page.

- Speed control range: 300 r/min ~ 3000 r/min
- Output power: 75W, 120W

These products combine a compact, powerful, constant torque motor with a slim-line driver. They offers compact size, high output and precise, flexible control. Connections are simple because of the snap connectors.

The **GFB** type high torque gearheads are also available.

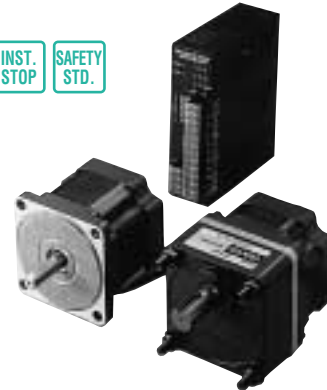

HBL Series A-132 page.

- Speed control range: 300 r/min ~ 2000 r/min
- Output power: 10W ~ 100W

The **HBL** Series are DC 24V or DC 48V-driven brushless DC speed control motors consisting of slim, powerful motors and compact drivers.

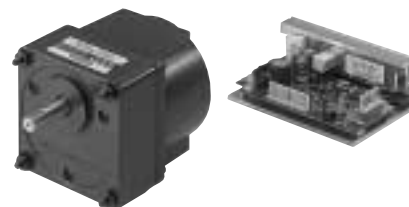

(The gearhead for 10W, 25W and 40W is sold separately.)

SC Series

A-142 page.

- Speed control range: 90 r/min ~ 1400 r/min (50Hz)
90 r/min ~ 1600 r/min (60Hz)
- Output power: 6W~60W
- Induction motor type, Reversible motor type.

Multi-functional operation including speed control, acceleration / deceleration is made possible by the combination of a control pack and a speed control motor. The control pack can be installed in a control panel.



Motor

Control Unit



(The gearhead shown is sold separately.)

US Series

A-156 page.

- Speed control range: 90r/min ~ 1400 r/min(50Hz)
90r/min ~ 1600 r/min(60Hz)
- Output power: 6W ~ 90W
- Induction motor type

Unit consisting of a compact control unit and a speed control motor. One-step connectors make for easy wiring.



(The gearhead shown is sold separately.)

Component Type

A-170 page.

- Speed control range: 90 r/min ~ 1700 r/min
- Output power: 6W ~ 40W
- Induction motor type

The combination of a motor with a control pack allows for highly versatile operation, tailored to your needs.

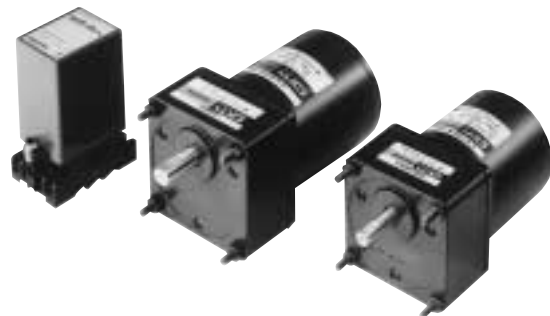

(The gearhead shown is sold separately.)

Guide for Speed Control Motor Selection

■ Selection Procedure

1. Selecting a motor and control pack

First, determine :

- Required functions (Instantaneous stop, Acceleration/Deceleration etc.)
- Power supply voltage (AC/DC)
- Required motor output power

2. Computing the gearhead ratio

The following equation is used to determine the gear ratio of the gearhead using the higher limit of required speed if a speed range between A [r/min] to B [r/min] is to be achieved.

$$i_x = \frac{1300 \text{ [r/min]}}{B \text{ [r/min]}} \text{ [AC speed control motors*]}$$

$$i_x = \frac{3000 \text{ [r/min]}}{B \text{ [r/min]}} \text{ [FBLII series]}$$

i_x : Speed reduction ratio

A: Lower limit of the required shaft speed range

B: Higher limit of the required shaft speed range

*AC speed control motors have the highest torque and the largest continuous duty region at around 1300r/min.

Use a gearhead with the gear ratio “i” closest to, but still below, the calculated value.

3. Corresponding motor speed range

With the speed-reduction ratio of the selected gearhead (i), the corresponding upper and lower value for the speed range at motor shaft N_H and N_L , respectively, are determined as follows:

$$N_H = B \times i \text{ [r/min]}$$

$$N_L = A \times i \text{ [r/min]}$$

4. Corresponding minimum motor torque

The torque required at the motor shaft to drive the load with the gearhead attached is determined by the following equation:

$$T_M = \frac{T_L}{i \cdot \eta} \text{ [oz-in]}$$

T_M : Torque required at the motor output shaft

T_L : Load torque

i : Gear ratio

η : Gearhead efficiency

5. Selecting the right motor

The main parameters for motor selection in a given application are the values for the torque required at the motor output shaft, the required speed range N_L - N_H and the torque-speed characteristics of the motor.

● AC speed control motor

To determine whether a motor is suitable, a line (ℓ) is entered into the torque-speed characteristics curve that connects the value for N_L and N_H as the coordinates to the abscissa (T_M), as shown in the figure below. If this line is entirely to the left of the “safe-operation line”, continuous operation of the motor is generally possible. (If the line “ ℓ ” is partly or entirely to the right of the “safe-operation line”, but still within the range below the stall torque, the motor may be suitable as long as the motor temperature is kept below the 194°F (90°C) limit by such methods as forced-air cooling or intermittent operation of the unit. On the other hand, if ℓ is far to the left of the “safe-operation line”, the motor under consideration is oversized and, therefore, not economically suitable for the application.)

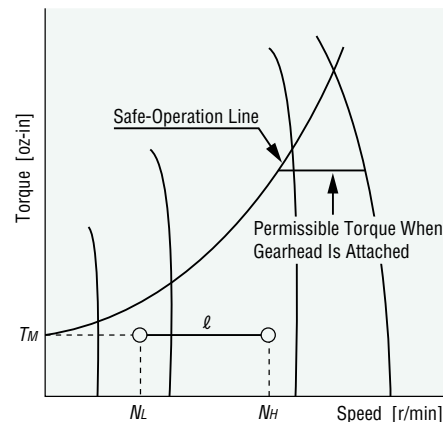

● FBLII series

Determine if the line (ℓ) is entirely inside the “continuous duty region”.

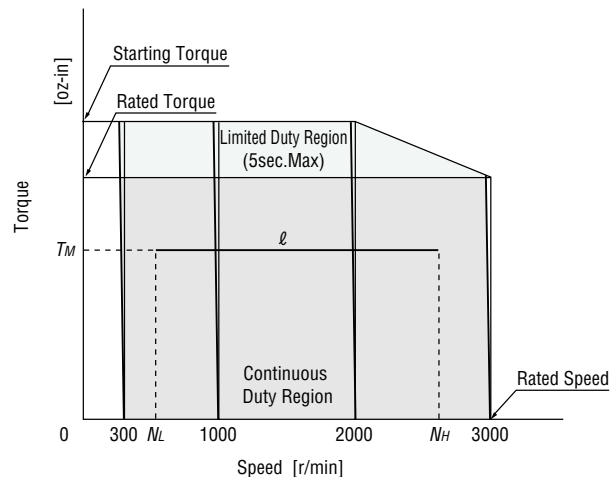

6. Selecting the right gearhead

Find the maximum permissible torque of the gearhead, using the required speed reduction ratio (i_x) in the gearhead data provided with every speed control motor. Any combination of a suitable motor with a gearhead whose maximum permissible torque is higher than the load torque can be used for the application. The final selection must be carried out according to other criteria (e.g. temperature rise, size, etc.)

■ Sample Calculation for Selecting a Speed Control System

Conditions

● Belt Conveyor with Uni-directional Rotation

The speed of feed can be set in the range between 50 in/min and 200 in/min in order to match the work being moved by the manual speed adjustment.

- Drum diameter: 5 inch DIA.
- Drive torque: 30 lb-in (= 480 oz-in)
- Power supply: Single-Phase 115 VAC, 60 Hz

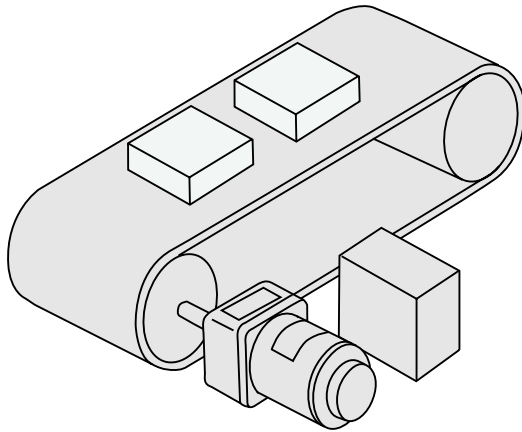

1. Motor and Control Pack

Select a product from the unit type speed control motor **US** series, for easy wiring.

2. Gearhead Output Shaft Speed

Gear shaft speed when the belt conveyor is moving at 50 in/min is:

$$\frac{\text{Belt conveyor speed}}{\text{Drum outer diameter}} = \frac{50}{5\pi} \doteq 3.18 \text{ [r/min]}$$

Gear shaft speed when the belt conveyor is moving at 200 in/min is:

$$= \frac{200}{5\pi} \doteq 12.7 \text{ [r/min]}$$

3. Gear Ratio of Gearhead

Find the gear ratio using the highest gear shaft speed as the standard.

$$\frac{\text{Motor shaft speed}}{\text{Gear shaft speed}} = \frac{1300}{12.7} \doteq 102 \rightarrow \boxed{100}$$

The gear ratio is therefore 100 : 1.

4. Motor Shaft Speed

$$\begin{aligned} \text{Gear shaft speed} \times \text{Gear ratio} &= 3.18 \times 100 = 318 \text{ [r/min]} \\ &= 12.7 \times 100 = 1270 \text{ [r/min]} \end{aligned}$$

5. Required Motor Torque

The efficiency of a gearhead with a gear ratio of 100:1 is 0.66. The required motor torque is:

$$\frac{\text{Drive torque}}{\text{Gear ratio} \times \text{Efficiency}} = \frac{480}{100 \times 0.66} \doteq 7.3 \text{ [oz-in]} (52.6 \text{ mN} \cdot \text{m})$$

6. Motor Selection

These calculations indicate that the best combination from those listed on the torque-speed curves for the **US** series (page A-156) is:

Motor : **US425-401U**
Gearhead : **4GN100KA**

In this example, an AC speed control motor was chosen, but depending on the required motor torque, motor size limitations, and required speed, the **FBLII** and **HBL** Series motors may sometimes be better choices. Follow the same procedure to select one of these motors. The only additional step is to check that the load inertia falls within the selected motor's specifications.

■ Characteristics of the **FBL II** and **HBL** Series

● Constant Torque Over a Wide Range of Speeds

These motors provide a constant level of torque over a wide range of speeds (300 ~ 3000 r/min for the **FBL II** series and 300 ~ 2000 r/min for the **HBL** series).

They both have continuous operation areas and short-term operation areas (about 5 seconds), so they are extremely effective at accelerating inertial loads.

● Power Beyond Their Size

Brushless DC motors are used, which produce more power than AC speed control motors of the same size.

● Closed-Loop Speed Control System

Basic Configuration

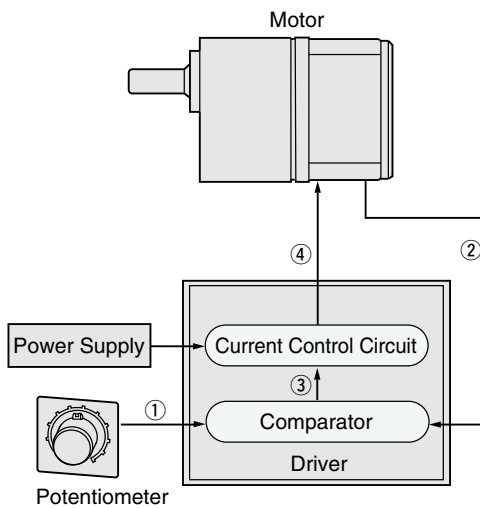

- ① The speed setting voltage is supplied by a potentiometer.
- ② The motor speed is sensed and the speed signal voltage is supplied.
- ③ The difference between the speed setting voltage and speed signal voltage is the output.
- ④ A current determined by the output from the comparator is supplied to the motor so it reaches the set speed.

● **FBL II** Series Torque-Speed Characteristics

FBL5120AW-□

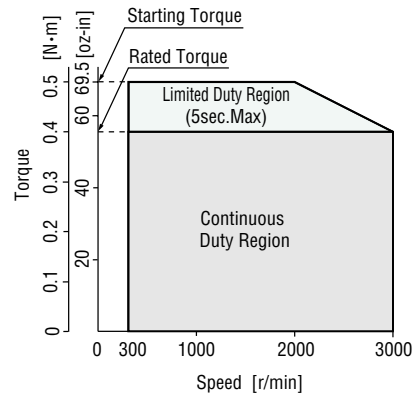

The figure above illustrates the characteristics of an **FBL II** series motor. Except for a speed control range of 300 ~ 2000 r/min, the characteristics are the same for the **HBL** series. Rated torque and instantaneous maximum torque are constant from 300 r/min to 3000 r/min. The torque does not drop at low speeds, as it does for AC speed control motors. Unlike AC speed control motors, which have a limit to continuous use because of the motor's temperature rise, brushless DC motors can be used continuously at rated torque from high speeds to low.

In addition to their continuous use areas, brushless DC motors also have short-term use areas. In the short-term use area, an instantaneous maximum torque that is about 1.3 times the rated torque can be output. This is extremely effective for accelerating inertial loads. If operated for more than about 5 seconds in the short-term use area, the driver's overload protection function engages and the motor is automatically stopped.

■ Characteristics of AC Speed Control Motors

The most commonly used of all general-purpose compact AC motors is the induction motor. Speed Control motors are equipped with a tachogenerator as a speed sensor, which, together with the specially designed control pack, allows speed control over a wide range of 90 ~ 1600 or 1700 r/min (for 60Hz). A speed control motor's speed can be set and adjusted by a speed potentiometer. The phase controlled lower voltage, which is applied to the motor, helps to keep motor temperature rise low in low speed or light load operations.

● Closed-Loop Speed Control System

Basic Configuration

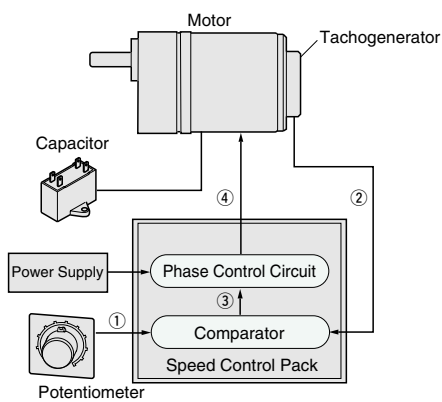

- ① The speed setting voltage is supplied by a potentiometer.
- ② The motor speed is sensed and the speed signal voltage is supplied.
- ③ The difference between the speed setting voltage and speed signal voltage is the output.
- ④ A voltage determined by the output from the comparator is supplied to the motor so it reaches the set speed.

● Safe-Operation Line and Continuous Duty Region

Torque-Speed Characteristics

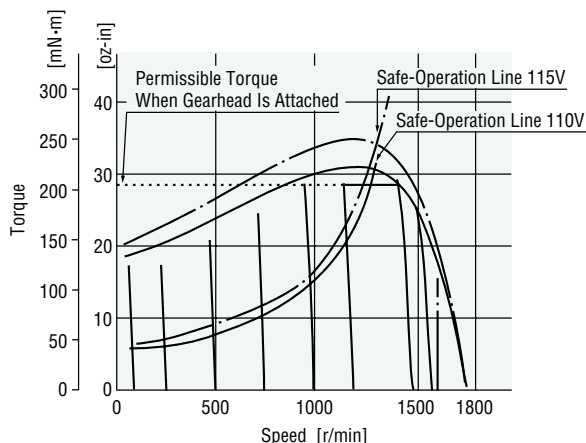

The speed-torque characteristic line shown in the figure above is typical for all AC speed control motors. Up to a certain maximum torque, the "stall torque", an increase of load has almost no influence on the motor speed. Exceeding this value for maximum torque will lead to sudden stalling of the motor.

● Safe-Operation Line

Input power to the speed control motor varies with the load and the speed. The greater the load, and the lower the speed, the higher the motor's temperature will rise.

The graph left displays the relationship between the speed and the torque characteristics of the AC speed control motor. The line is referred to as the safe-operation line and the shaded area is called the continuous operation area.

The safe-operation line, measured by motor's temperature, indicates its operational limit for continuous usage with the temperature level below the permissible maximum (In case of using the reversible motor, it is measured by 30 minute operation).

Whether the motor can be operated continuously or not is judged by measuring the temperature of the motor case. When the temperature of the case is below 194°F(90°C), the motor is capable of continuous operation.

When using a gearhead, be aware that it is necessary to operate below the maximum permissible torque.

If the actual torque required should exceed the maximum permissible torque, it may cause possible damage to the motor and/or may shorten its life.

FBL II Series

The **FBL II** series consists of a high performance, compact, brushless DC motor and driver. This product is available with 75W and 120W output power.

For easy installation, the motor and gearhead come pre-assembled.



Product Number Code

FBL 5 75 A W - 5

Number: Gear Ratio
A: Round Shaft Type
W: Conform to standards
Voltage A: Single-Phase 100V-115V
C: Single-Phase 200V-230V
S: Three-Phase 200V-230V

Output Power **75:** 75W
120: 120W

Motor Frame Size **5:** 3.54 in. sq (90 mm sq.)

FBL II series

* Approved product names under all safety standards will refer to motor units and driver units.

Features

- The high power, compact brushless DC motor and driver allow the user to easily downsize applications.
- In addition to offering a wide speed control range from 300r/min to 3000r/min, the motor generates constant torque across the entire speed range.
- The driver is provided with an acceleration/deceleration function which makes it possible to start and stop the motor smoothly.
- Geared types use specially designed high-strength **GFB** gearheads that provide maximum permissible torques of 260 lb-in (30N·m).
- Excellent speed fluctuation characteristics of -1% maximum with load, $\pm 1\%$ maximum with voltage and $\pm 1\%$ maximum with temperature.
- The distance between the motor and the driver can be extended up to 35ft. (10.5m) by using an optional extension cable.

Safety Standards

The design conforms to typical global safety standards. Applications have been made for UL, CSA and EN standard approvals.

CE Marking

The CE Marking is being used in accordance with the low voltage directive.

Safety Standards and CE Marking

| | Standards | Certification Body | Standards File No. | CE Marking |
|------------------------|-----------------------|--------------------|--------------------|-----------------------|
| Motor | UL1004 | UL | E62327 | Low Voltage Directive |
| | CAN/CSA-C22.2 No. 100 | | | |
| | EN60950 | DEMKO* | 124888/DK 98-03353 | |
| EN60034-1 EN60034-5 | | | | |
| Driver | UL508C | UL | E171462 | Low Voltage Directive |
| | CAN/CSA-C22.2 No.14 | | | |
| | EN60950 | DEMKO* | 124886/DK 98-03350 | |

* Three-Phase 200-230V type conform to EN standards (EN certifications are scheduled).

- Recognized name and certified name of each safety standards are motor model name and driver name.
- For installation conditions for EN/IEC standards, see page D-2.

Combination type

The combination type come with the motor and its dedicated gearhead already assembled. This simplifies installation in equipment. Motors and gearheads are also available separately so they can be on hand to make changes or repairs.

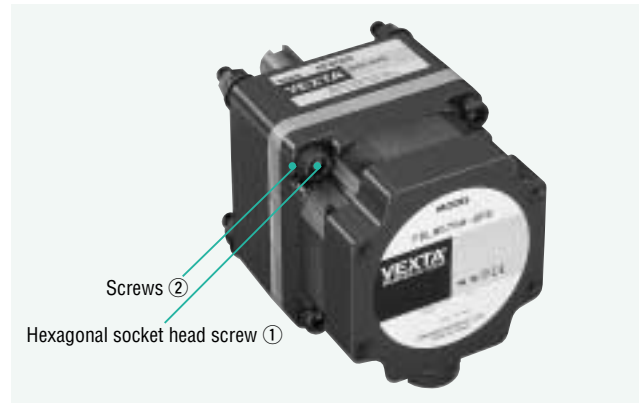

Install the motor and gear combination using the four hexagonal socket head screws ①.
To replace the gearhead, remove the two small screws ②.

Product Lines

Combination Models

| Voltage | Output Power | | Model |
|---------------------------|--------------|-----|---|
| | HP | W | |
| Single-Phase 100V-115V | 1/10 | 75 | FBL575AW-5, 10, 15, 20 FBL575AW-30, 50, 100, 200 |
| | | 120 | FBL5120AW-5, 10, 15, 20 FBL5120AW-30, 50, 100, 200 |
| | 1/6 | 75 | FBL575CW-5, 10, 15, 20 FBL575CW-30, 50, 100, 200 |
| | | 120 | FBL5120CW-5, 10, 15, 20 FBL5120CW-30, 50, 100, 200 |
| Single-Phase 200V-230V | 1/10 | 75 | FBL575SW-5, 10, 15, 20 FBL575SW-30, 50, 100, 200 |
| | | 120 | FBL5120SW-5, 10, 15, 20 FBL5120SW-30, 50, 100, 200 |
| | 1/6 | 75 | FBL575SW-5, 10, 15, 20 FBL575SW-30, 50, 100, 200 |
| | | 120 | FBL5120SW-5, 10, 15, 20 FBL5120SW-30, 50, 100, 200 |

Round shaft Models

| Voltage | Output Power | | Model |
|---------------------------|--------------|-----|--------------------|
| | HP | W | |
| Single-Phase 100V-115V | 1/10 | 75 | FBL575AW-A |
| | 1/6 | 120 | FBL5120AW-A |
| Single-Phase 200V-230V | 1/10 | 75 | FBL575CW-A |
| | 1/6 | 120 | FBL5120CW-A |
| Three-Phase 200V-230V | 1/10 | 75 | FBL575SW-A |
| | 1/6 | 120 | FBL5120SW-A |

Construction

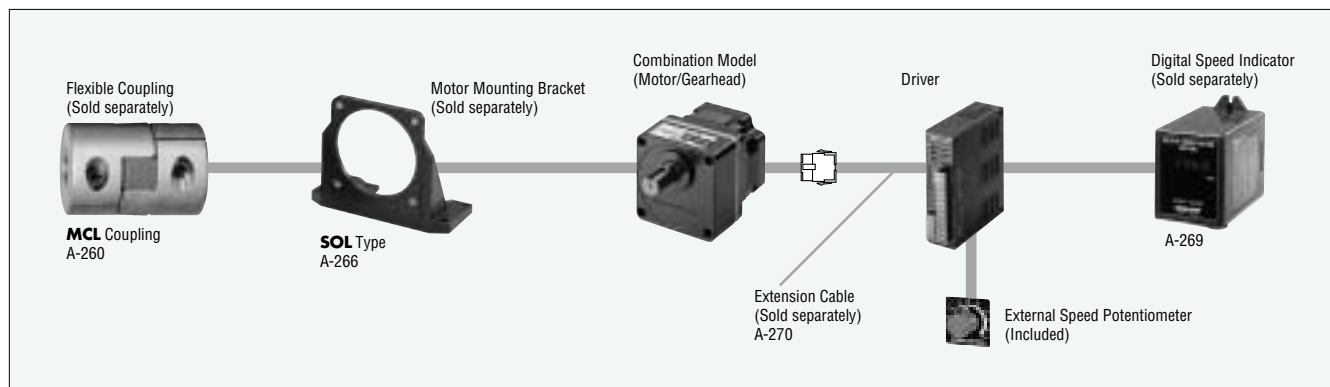

Specifications



| | | 1/10 HP 75W | | | 1/6 HP 120W | | |
|---|--|---|---------------------------------|--------------------------------|---------------------------------|---------------------------------|--------------------------------|
| | | Single-phase 100V-115V ± 10% | Single-phase 200V-230V ± 10% | Three-phase 200V-230V ± 10% | Single-phase 100V-115V ± 10% | Single-phase 200V-230V ± 10% | Three-phase 200V-230V ± 10% |
| Model | Combination Type | FBL575AW -□ | FBL575CW -□ | FBL575SW -□ | FBL5120AW -□ | FBL5120CW -□ | FBL5120SW -□ |
| | Round Shaft Type | FBL575AW-A | FBL575CW-A | FBL575SW-A | FBL5120AW-A | FBL5120CW-A | FBL5120SW-A |
| Rated Speed | r/min | 3000 | | | | | |
| Rated Torque | oz-in (N·m) | 34.7 (0.25) | | | 55.5 (0.4) | | |
| Starting Torque | oz-in (N·m) | 44.4 (0.32) | | | 69.4 (0.5) | | |
| Variable Speed Range | r/min | 300~3000 | | | | | |
| Permissible Inertial Load J* ¹ | oz-in ² (kgm ²) | 20.5 (3.75×10 ⁻⁴) | | | 30.7 (5.6×10 ⁻⁴) | | |
| Acceleration/Deceleration Time | | 0.5~15 sec. (at 3000 r/min) | | | | | |
| Speed Regulation | Load | -1% Max. (0~rated torque, at 3000 r/min) | | | | | |
| | Voltage | ±1% Max. (Power supply voltage ±10%, at 3000 r/min with no load) | | | | | |
| | Temperature | ±1% Max. (32°F~+104°F/0°C~+50°C) at 3000 r/min with no load | | | | | |
| Input Power | Voltage | Single-phase 100V-115V ± 10% | Single-phase 200V-230V ± 10% | Three-phase 200V-230V ± 10% | Single-phase 100V-115V ± 10% | Single-phase 200V-230V ± 10% | Three-phase 200V-230V ± 10% |
| | Frequency | 50/60Hz | | | | | |
| | Maximum Input Current | 2.6A | 2.0A | 1.2A | 3.8A | 1.6A | 1.6A |
| Motor Insulation Class | | Class E [248°F(120°C)]* ³ | | | | | |
| Speed Control Method | | 1. By built-in potentiometer 2. By external potentiometer (20 kΩ, 1/4W) 3. By DC voltage (0~5V DC) | | | | | |
| Input Signal | | Photocoupler Input Input Impedance 4.8 kΩ, 21.6~26.4V DC EXT, VR, CW, CCW, SLOW DOWN | | | | | |
| Output Signal | | Open Collector Output External Use Condition 24V DC, 10mA Max. SPEED OUT, ALARM OUT | | | | | |
| Protection Functions* ² | | When the following are activated, the alarm signal will be output and the motor will come to a stop: <ul style="list-style-type: none"> ●Overload Protection: This will be activated within approximately 5 seconds of the motor load exceeding rated torque. ●Overheat Protection: This will be activated when internal temperature of driver exceeds 162°F (90°C). ●Overvoltage Protection: This will be activated when driving a load exceeding the permissible load inertia, or when motor speed is increased due to gravitational forces. ●Out-of-phase Protection: This will be activated when motor signals are abnormal, due to disconnection of cable, etc. ●Under Voltage Protection: This will be activated when a input voltage to the driver is less than specifications voltage. | | | | | |
| Rating | | Continuous | | | | | |

*1: The permissible inertial load specified above is only applicable for round shaft type.

*2: With the **FBLII** series, motor speed cannot be controlled in applications where the motor's shaft is turned by the load, as in lowering operations. Also, to prevent damage to the driver during lowering operations, the motor comes to a natural stop if the primary voltage of the driver's inverter e exceeds the permissible value.

*3: Motor insulation is recognized as class A (105°C) by UL and CSA standards.

General Specifications

| Item | | Motor | Driver |
|------------------------------------|---------------------|--|---|
| Insulation Resistance | | 100M Ω or more when 500V DC is applied between the windings and the frame. | 100M Ω or more when 500V DC is applied between the power supply input terminal and the P.E. terminal (I/O terminal). |
| Dielectric Strength | | Sufficient to withstand 1.5kV at 50Hz applied between the windings and the frame for 1 minute. | Sufficient to withstand 1.8kV (3kV) AC at 50Hz applied between the P.E. terminal (I/O terminal) and the power supply input terminal for 1 minute. |
| Operating Environmental Conditions | Ambient Temperature | 32°F~122°F (0°C~+50°C), nonfreezing | 32°F~122°F (0°C~+50°C), nonfreezing |
| | Humidity | 85% maximum, noncondensing | |
| | Atmosphere | No corrosive gases or dust | |
| Degree of Protection | | IP40 | IP10 |

■ Gearmotor — Torque Table

Unit = Upper value: lb-in/Lower values: N·m

| Gear Ratio | | 5 | 10 | 15 | 20 | 30 | 50 | 100 | 200 |
|--|-------------------|--------|--------|--------|--------|--------|------|------|--------|
| Model | Speed Range r/min | 60~600 | 30~300 | 20~200 | 15~150 | 10~100 | 6~60 | 3~30 | 1.5~15 |
| FBL575AW- <input type="checkbox"/> | | 9.8 | 20 | 29 | 39 | 56 | 93 | 187 | 260 |
| FBL575CW- <input type="checkbox"/> | | 1.1 | 2.3 | 3.4 | 4.5 | 6.5 | 11 | 22 | 30 |
| FBL575SW- <input type="checkbox"/> | | | | | | | | | |
| FBL5120AW- <input type="checkbox"/> | | 16 | 31 | 47 | 62 | 89 | 149 | 260 | 260 |
| FBL5120CW- <input type="checkbox"/> | | 1.8 | 3.6 | 5.4 | 7.2 | 10 | 17 | 30 | 30 |
| FBL5120SW- <input type="checkbox"/> | | | | | | | | | |

- Enter the gear ratio in the box () within the model number. A colored background indicates gear shaft rotation in the same direction as the motor shaft; a white background indicates rotation in the opposite direction.

■ Permissible Overhung Load · Permissible Thrust Load

Unit = Upper value: lb. / Lower value: N

| Gear Ratio | | 5 | 10 | 15 | 20 | 30 | 50 | 100 | 200 |
|--|--|-----------|----|------------|----|----|----|------------|-----|
| Permissible Thrust Load | | 33 150 | | | | | | | |
| Permissible Overhung Load [0.4 in. (10mm) from shaft end] | | 66 300 | | 88 400 | | | | 110 500 | |
| Permissible Overhung Load [0.8 in. (20mm) from shaft end] | | 88 400 | | 110 500 | | | | 143 650 | |

- Enter the gear ratio in the box () within the model number.

■ Permissible Inertial Load (J)

Unit = Upper value: lb-in² / Lower values: ×10⁻⁴kgm²

| Model | Gear Ratio | 5 | 10 | 15 | 20 | 30 | 50 | 100 | 200 |
|--|------------|-----|-----|------|-----|-----|------|------|------|
| FBL575AW- <input type="checkbox"/> | | | | | | | | | |
| FBL575CW- <input type="checkbox"/> | | 8.5 | 34 | 76.5 | 136 | 306 | 850 | 850 | 850 |
| FBL575SW- <input type="checkbox"/> | | | | | | | | | |
| FBL5120AW- <input type="checkbox"/> | | 25 | 100 | 225 | 400 | 900 | 2500 | 2500 | 2500 |
| FBL5120CW- <input type="checkbox"/> | | | | | | | | | |
| FBL5120SW- <input type="checkbox"/> | | | | | | | | | |

- Enter the gear ratio in the box () within the model number.

■ Torque — Speed Characteristics

● Continuous Duty Region

Continuous operation is possible in this region.

● Limited Duty Region

This region is used primarily when accelerating. When a load that exceeds the rated torque is applied continuously for approximately 5 seconds, overload protection is activated and the motor comes to stop.

FBL575AW-**/FBL575CW-****/FBL575SW-**
FBL575AW-A/FBL575CW-A/FBL575SW-A

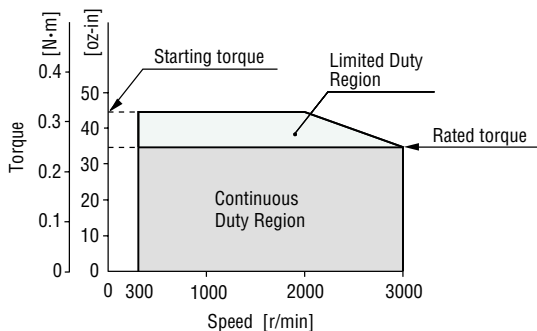

FBL5120AW-**/FBL5120CW-****/FBL5120SW-**
FBL5120AW-A/FBL5120CW-A/FBL5120SW-A

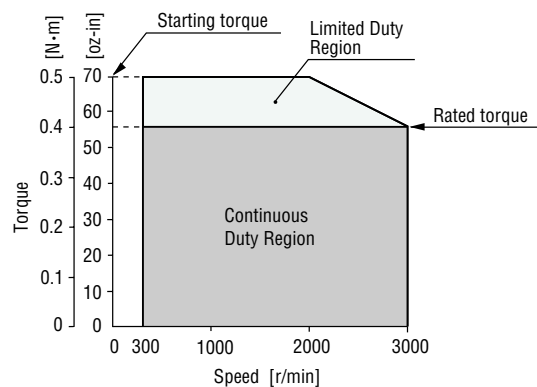

■ Load Torque - Driver Input Current Characteristics

Driver input current of brushless DC motors varies with the load torque. Load torque is roughly proportional to driver input current. These characteristics may be used to estimate load torque from the driver input current. It is valid only when the motor is rotating at a steady speed. Starting and bi-directional motions require greater current input, so the relationship does not apply to these operations.

FBL575AW-□

FBL575AW-A

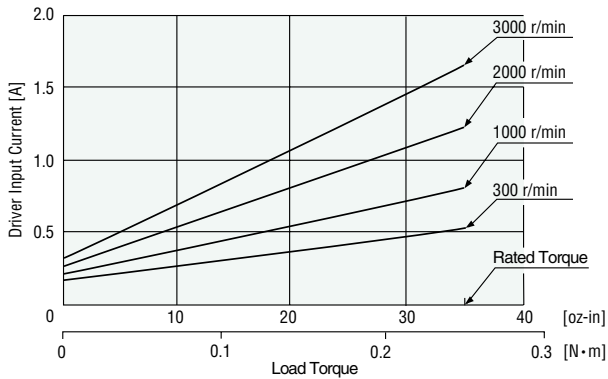

FBL575CW-□

FBL575CW-A

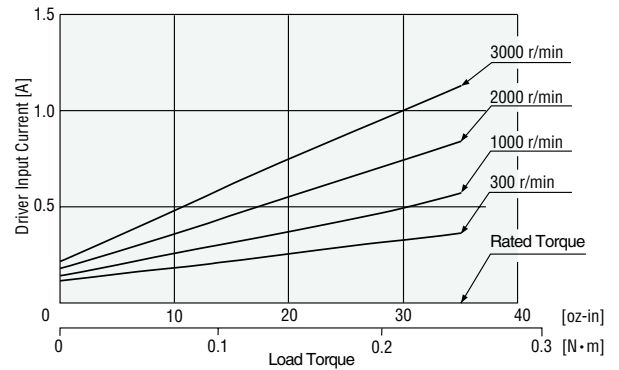

FBL575SW-□

FBL575SW-A

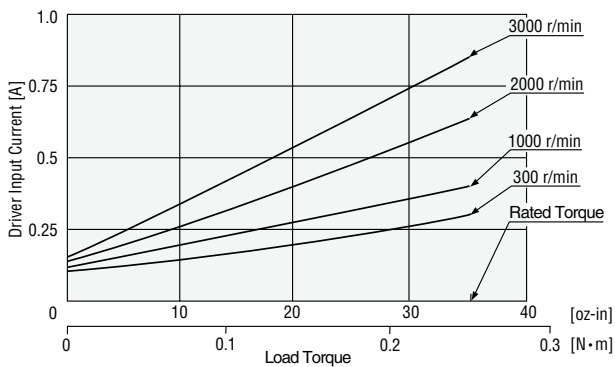

FBL5120AW-□

FBL5120AW-A

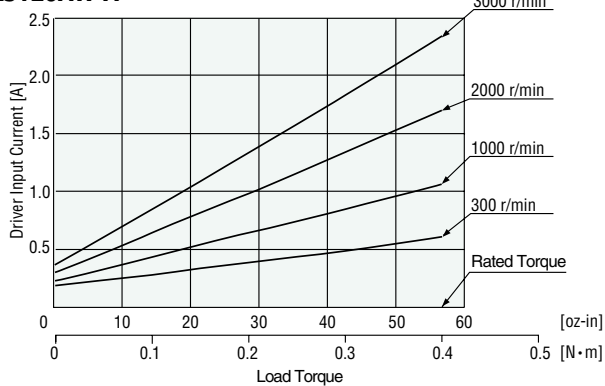

FBL5120CW-□

FBL5120CW-A

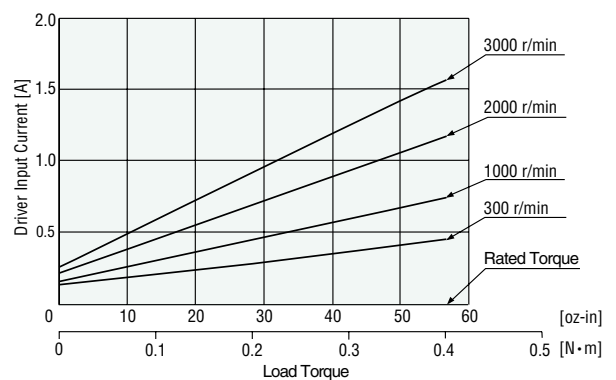

FBL5120SW-□

FBL5120SW-A

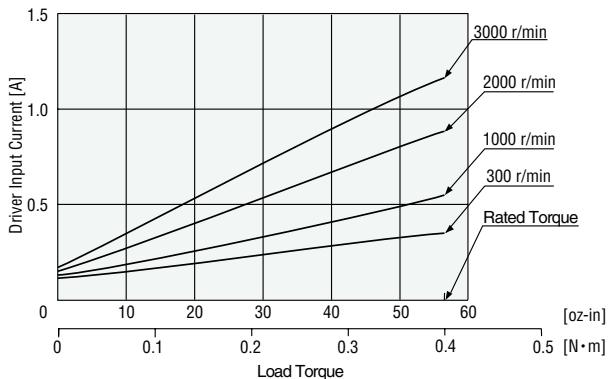

Operation of FBL II Series

Driver Functions

| Built-in Potentiometer | |
|------------------------|---------------------------------------|
| Display | Function |
| SS | Timing Potentiometer for Acceleration |
| SD | Timing Potentiometer for Deceleration |
| SPEED | Speed Potentiometer |

For Motor Connector

Power Supply Terminal



| LED Display | | |
|-------------|-----------------|---|
| Display | Function | Lighting Condition |
| POWER | Power Indicator | Lights when the power is ON. |
| ALARM | Alarm Indicator | <ul style="list-style-type: none"> ●When a load exceeding the rated torque is applied to the motor for 5 seconds or more. ●When the driver's internal temperature exceeds approximately 162°F (90°C). ●When the motor is driving an inertial load exceeding the permissible inertial load, or when the motor shaft is turned by the load (during lowering operation). ●When there is an abnormality in the motor's feedback signals due to disconnection of the motor cable, etc. ●When an input voltage to the driver is less than specification voltage. |

| I/O Power Supply Switch | |
|-------------------------|---|
| Display | Function and Operation |
| EXT | When controlling from a PLC or other external power supply. (Set at time of shipment) |
| INT | When controlling with a relay or switch. (Driver built-in power supply) |

When the switch is set to EXT, the input circuit is insulated by the photocoupler. However when the switch is set to INT, the input circuit is not insulated, so the system will not work, even if an input signal is input, unless GND is connected to a PLC.

| Input/Output Signal Terminals | | |
|-------------------------------|---|--|
| Display | Signal | Function and Operation |
| INPUT COM | Power Supply for Input Signal | External DC power supply +24V A connection is not necessary when using the driver's built-in power supply. |
| EXT. VR | Speed Potentiometer Selection Input | Input signal for selecting built-in or external speed potentiometer. |
| CW | CW Rotation Input | Input signal for selecting CW rotation/stop. |
| CCW | CCW Rotation Input | Input signal for selecting CCW rotation/stop. |
| SLOW DOWN | Deceleration Input | Input terminal for decelerating the motor to a stop. |
| N.C | — | Not used. |
| H M L | Speed Control Input | Used when controlling the speed by the external potentiometer or DC voltage without use of the built-in potentiometer. |
| GND | Ground | Ground terminal for input/output signals. |
| SPEED OUT | Speed Signal Output (Open-Collector Output) | Used when monitoring the rate of rotation; 12 pulses are output for each motor rotation. |
| ALARM OUT | Alarm Signal Output (Open-Collector Output) | This signal is output when the protection functions are activated. The ALARM LED lights and the motor comes to a stop. To reset, cut the power for 10 seconds, then turn motor on again. |

■ Wiring Diagrams

FBL575AW, FBL575CW Type FBL5120AW, FBL5120CW Type

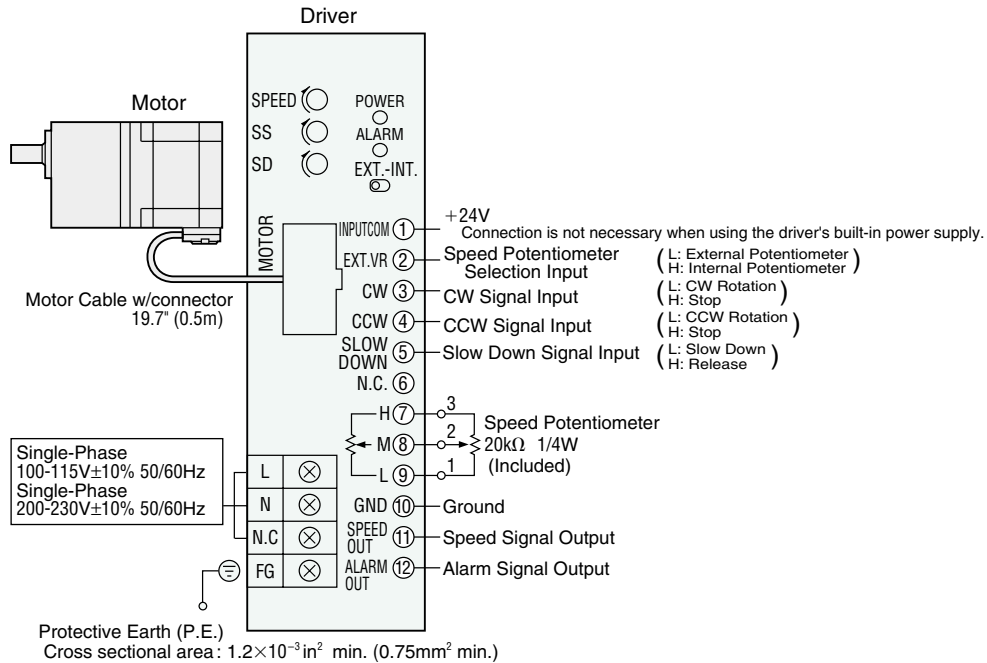

FBL575SW, FBL5120SW Type

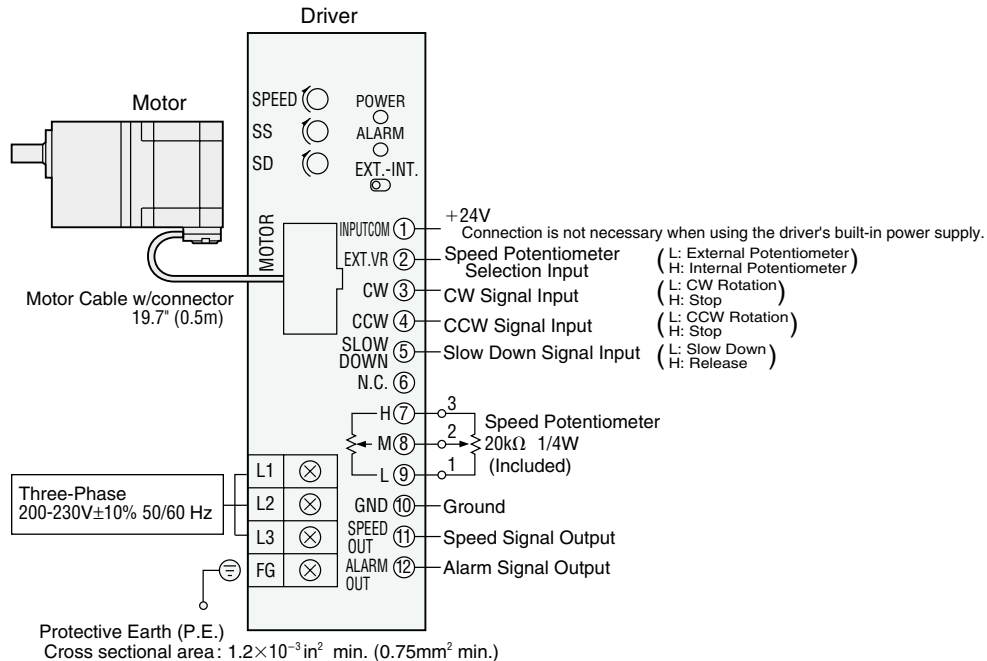

Note:

- Motor cable should be no more than 34 ft. (10.5m) in length. The motor comes equipped with a 1.6 ft. (0.5m) long connector-equipped cable which can be extended by using an optional extension cable. Extension Cable Model (Sold separately)

| | |
|-----------------------------|-------------------------------|
| CC01FBL 3.3 ft. (1m) | CC05FBL 16.4 ft. (5m) |
| CC02FBL 6.6 ft. (2m) | CC07FBL 23.0 ft. (7m) |
| CC03FBL 9.8 ft. (3m) | CC10FBL 32.8 ft. (10m) |

See page A-147 for more information.

Tests using a noise simulator have confirmed that the motor will operate without error even if a noise of 500V, 1μF is applied to the motor lead wires. However, protection against external noise is recommended.

- Signal wires and motor wires should be kept away from equipment, power cables and other sources of magnetic noise.

● Suitable crimp-style terminals Unit = inch (mm)

Ring type terminal with insulation U type terminal with insulation

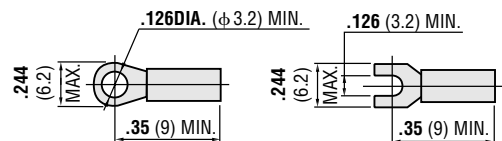

Signal Input Timing Chart

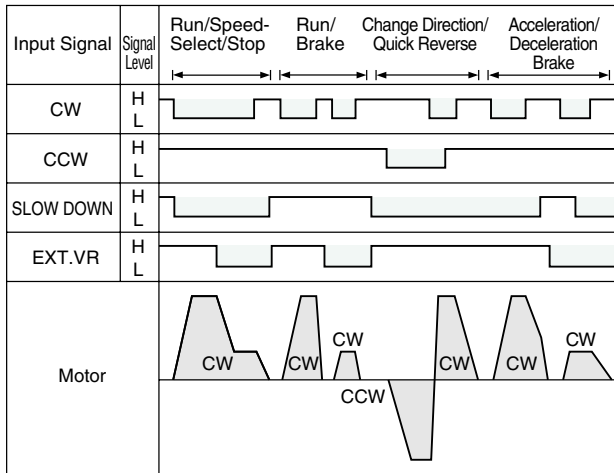

- All operations of run, stop, direction change, deceleration and instantaneous stop can be controlled by the input signals of CW, CCW and SLOW DOWN.
- If the CW input is set to "L" level, the motor rotates in a clockwise direction as viewed from the shaft end of the motor; if the CW input is set to "H" level, the motor stops. If the CCW input is set to "L" level, the motor rotates in the counterclockwise direction as viewed from the shaft end of the motor; if the CCW input is set to "H" level, the motor stops. If both of the CW and CCW input are set to "L" level, the motor rotates in the clockwise direction. The acceleration time is set by the built-in acceleration potentiometer (SS).
- If the SLOW DOWN input is set to "L" level, the deceleration time is the value set by the built-in deceleration potentiometer (SD); if this input is set to "H" level, the motor stops instantaneously.
- If the EXT. VR input is set to "L" level, the external speed potentiometer or external DC voltage can be selected; if this input is set to "H" level, the built-in speed potentiometer is selected.

Controlled by Small Capacity Relays

Flip the I/O power supply switch to "INT.".

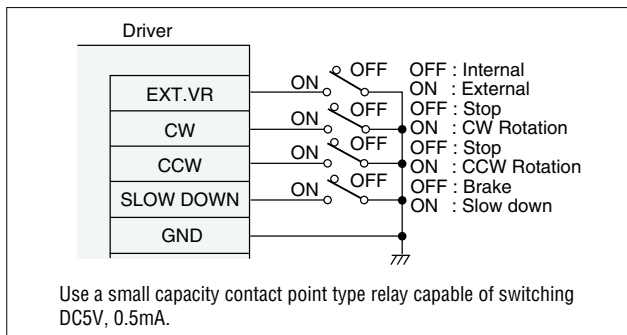

Precautions for Operation

1. Pay attention to the temperature rise of the motor when used in applications requiring short cycles or bi-directional operation.
2. Operate the motor so that the temperature of the motor case remains below 162°F (90°C) and the temperature of the driver remains 176°F (80°C). If the temperature of the heat radiating plate in the driver exceeds 162°F (90°C), the overheat protection activates and stops the motor.
3. **FBL II** series motors cannot be used for lowering the load or other operations in which the load exerts a rotational force on the motor shaft, since this causes the inverter's primary voltage in the driver to exceed permissible levels, damaging the driver.

Control by Transistor type PLC

Flip the I/O power supply switch to +24V (set at time of shipment).

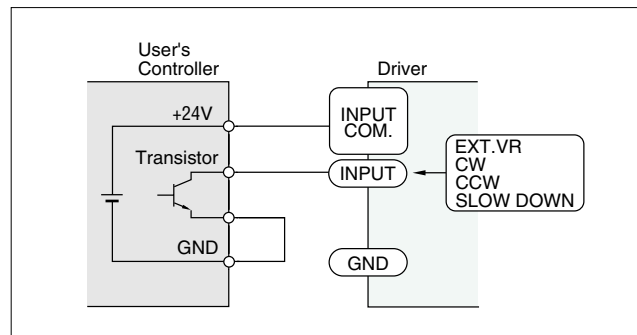

Input / Output Signal Circuit

Input Signal Circuit

Common to EXT. VR, CW, CCW and SLOW DOWN

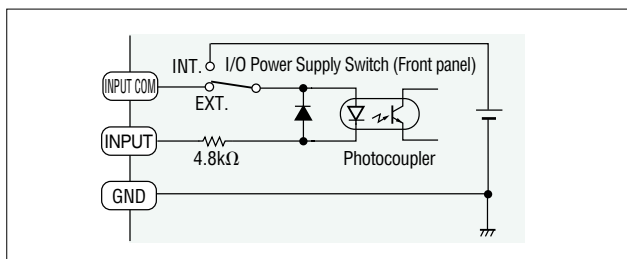

- If the controller will be supplying the power for this circuit, set the EXT-INT to the EXT. position.

Output Signal Circuit

Common to SPEED OUT and ALARM OUT

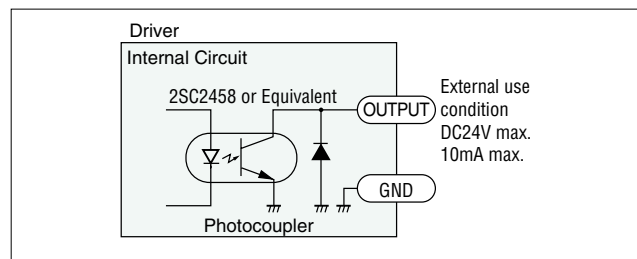

Speed Control

Speed Control by Built-in Potentiometer

Motor speed is adjusted by using a built-in potentiometer located on the front panel. The built-in potentiometer is selected when EXT. VR input has been set to OFF ("H" level).

Speed Control by External Potentiometer

To control the speed of the motor when it is separated from the driver, connect the external potentiometer provided with the motor as follows. The EXT. VR input should be set to ON ("L" level).

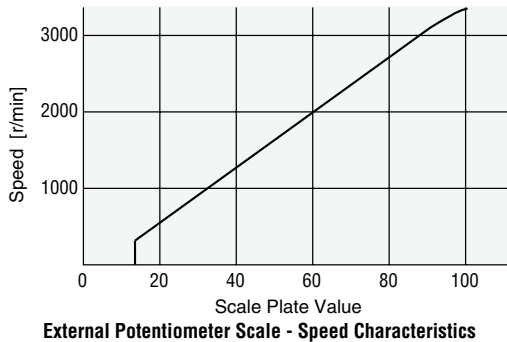
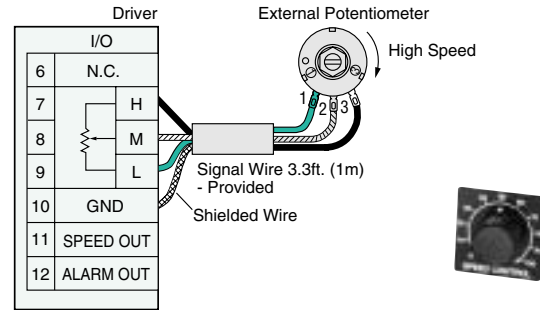

Precautions for Connection

Signal wires provided with the products should be used. (0.13in. dia. 3.3ft. long) The shielded wire of the signal line should be connected to the GND terminal. Also ensure that the shielded wire does not come into contact with other terminals on the external potentiometer or DC voltage source.

Connection of Output Signals

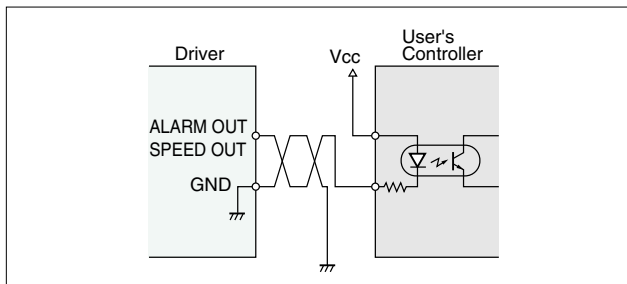

At 24V or less, a current of 10mA or less can be switched on and off at Vcc. This connection is necessary only if the speed monitoring and alarm functions are used.

- To check the motor speed visually, connect a speed indicator model **SDM496** (sold separately). See page A-269 for more information.

Speed Control by External DC Voltage

To control the speed of the motor by DC voltage, connect the DC power supply as follows. The EXT. VR input should be set to ON ("L" level).

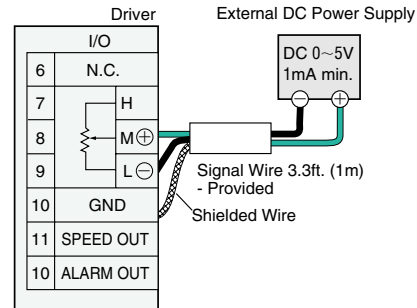

- Do not allow the voltage to exceed 5V, and be sure there are no errors in polarity when making the connections.

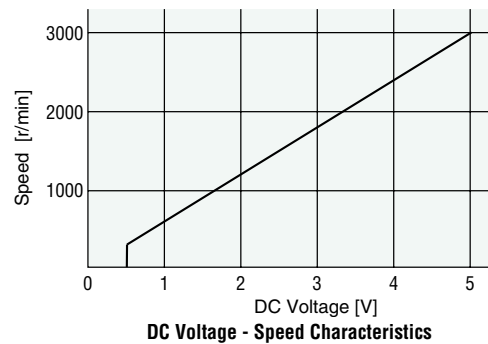

Speed Signal Output:

It is output at a rate of 12 pulses per motor rotation.

$$\text{Motor speed} = \frac{\text{Speed output cycle rate [Hz]} \times 60 [\text{r/min}]}{12}$$

Alarm Signal Output:

This signal is output when the protection function for overload, overheat, overvoltage or out-of-phase has been activated.

■ Dimensions Scale 1/4, Unit = inch (mm)

FBL575□W-□ (Combination Model) Weight (Mass): 6.6 lb. (3.0 kg)
 Motor: FBLM575W-GFB
 Gearhead: GFB5G□

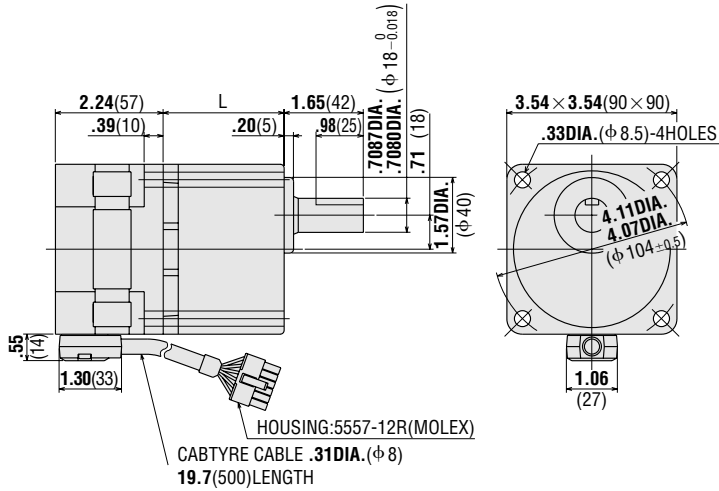

L = 1.77 (45) **FBL575□W-5~20**
 L = 2.28 (58) **FBL575□W-30~100**
 L = 2.52 (64) **FBL575□W-200**

FBL575□W-A (Round Shaft Type) Weight (Mass): 3.3 lb. (1.5 kg)
 Motor: FBLM575W-A

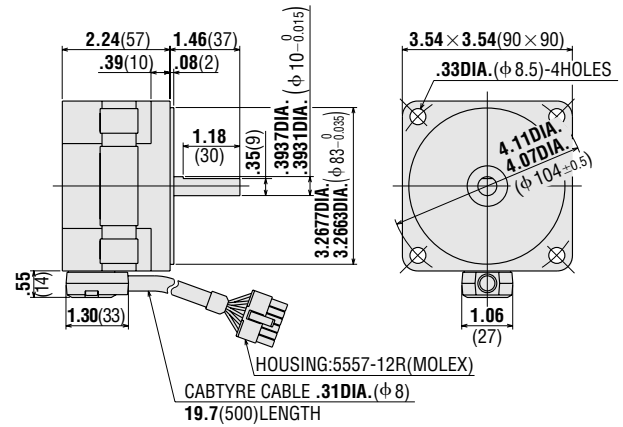

FBL5120□W-□ (Combination Model) Weight (Mass): 8.8 lb. (4.0 kg)
 Motor: FBLM5120W-GFB
 Gearhead: GFB5G□

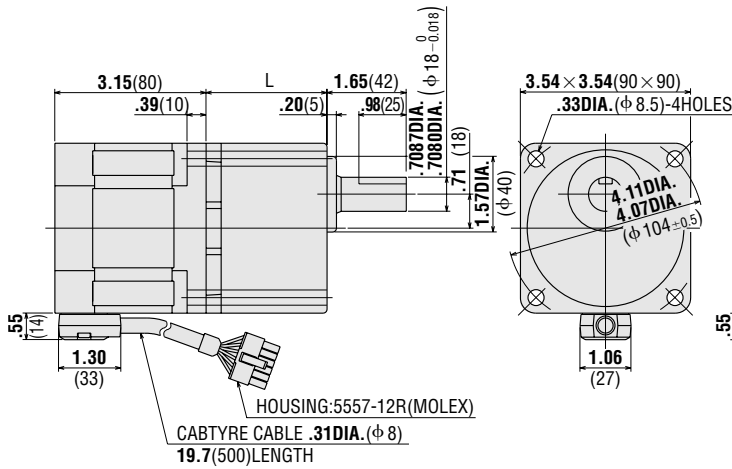

L = 1.77 (45) **FBL5120□W-5~20**
 L = 2.28 (58) **FBL5120□W-30~100**
 L = 2.52 (64) **FBL5120□W-200**

FBL5120□W-A (Round Shaft Type) Weight (Mass): 5.5 lb. (2.5 kg)
 Motor: FBLM5120W-A

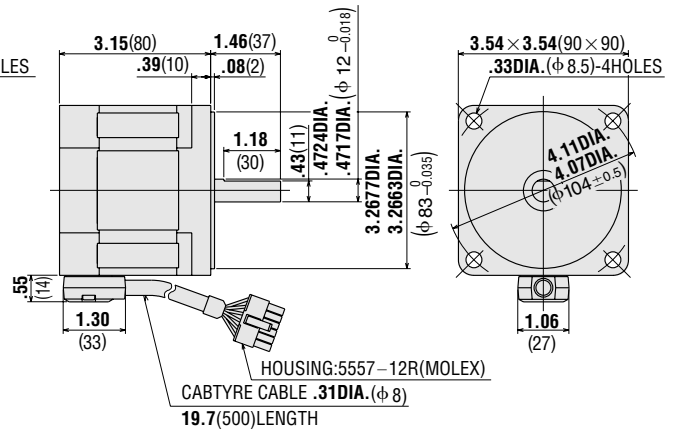

● Key and Key Slot (Scale 1/2)

(The key is provided with the gearhead.)

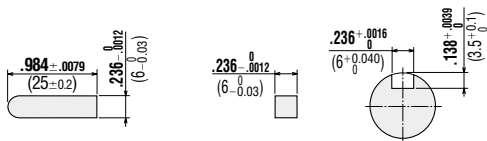

● **Driver**

FBLD75AW, FBLD75CW, FBLD75SW
 FBLD120AW, FBLD120CW, FBLD120SW

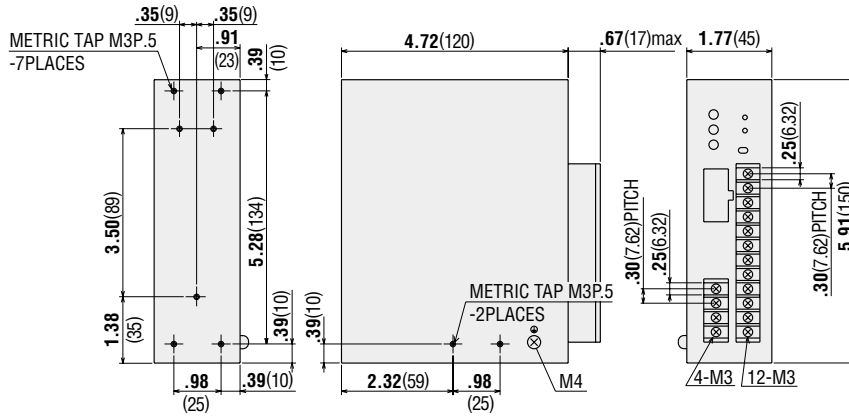

● **External Potentiometer (included)**

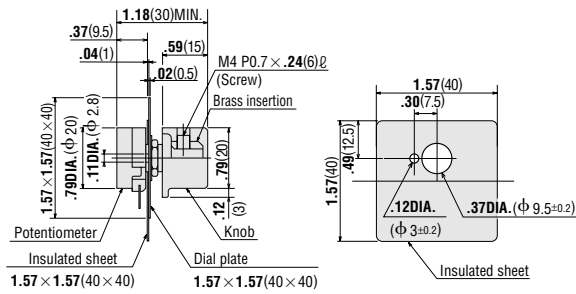

● **Driver Mounting Tab (1 set of 2 pieces included)**

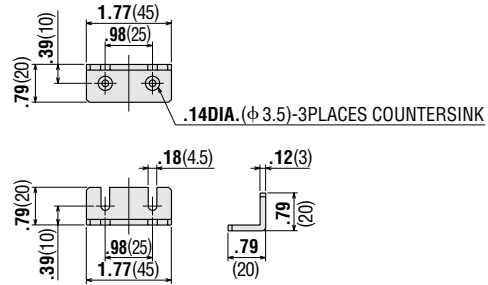

● **Driver Mounting Tab (1 piece included)**

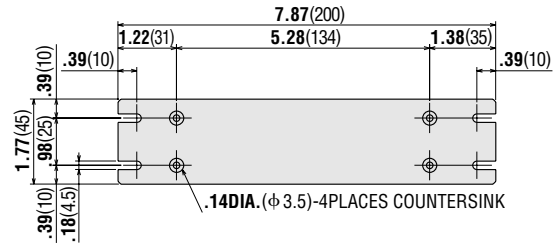

■ **List of Motor and Driver Combinations**

Model numbers for motor/driver combinations are shown below.

● **Combination Type**

| Output Power HP W | Package Model | Motor Model | Gearhead Model | Driver Model |
|-------------------------|---------------|---------------|----------------|--------------|
| 1/10 75 | FBL575AW-□ | FBLM575W-GFB | GFB5G□ | FBLD75AW |
| | FBL575CW-□ | | | FBLD75CW |
| | FBL575SW-□ | | | FBLD75SW |
| 1/6 120 | FBL5120AW-□ | FBLM5120W-GFB | | FBLD120AW |
| | FBL5120CW-□ | | | FBLD120CW |
| | FBL5120SW-□ | | | FBLD120SW |

● Enter the gear ratio in the box (□) within the model number.

● **Round Shaft Type**

| Output Power HP W | Package Model | Motor Model | Driver Model |
|-------------------------|---------------|-------------|--------------|
| 1/10 75 | FBL575AW-A | FBLM575W-A | FBLD75AW |
| | FBL575CW-A | | FBLD75CW |
| | FBL575SW-A | | FBLD75SW |
| 1/6 120 | FBL5120AW-A | FBLM5120W-A | FBLD120AW |
| | FBL5120CW-A | | FBLD120CW |
| | FBL5120SW-A | | FBLD120SW |

■ Accessories (Sold Separately)

● Motor Mounting Brackets

Optional die-cast aluminum mounting brackets are available. They can be used to install motors without gearheads. See page [A-266] for more information.

Model name: **SOL5M8**



● Flexible Couplings

Optional flexible coupling. See page [A-260] for more information.



● Digital Speed Indicator

To check the speed of speed control motors, connect the speed indicator. See page [A-269] for more information.

Model name: **SDM496**



● Extension Cable

The motor comes equipped with a 1.6 ft. (0.5m) long cable which can be extended by using an optional extension cable up to 35 ft. (10.5m).

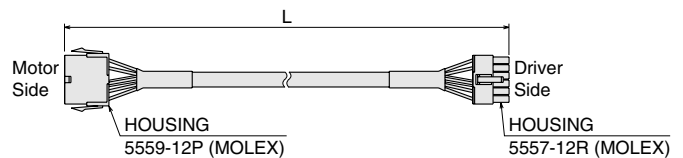
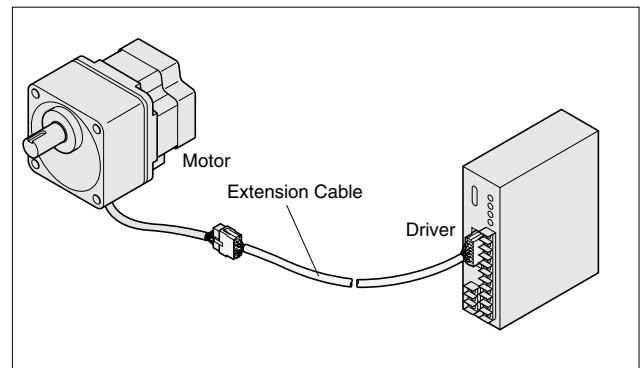

| Cable Model | Length | | Weight | |
|----------------|--------|----|--------|------|
| | ft. | m | lb. | kg |
| CC01FBL | 3.3 | 1 | 0.26 | 0.12 |
| CC02FBL | 6.6 | 2 | 0.48 | 0.22 |
| CC03FBL | 9.8 | 3 | 0.70 | 0.32 |
| CC05FBL | 16.4 | 5 | 1.17 | 0.53 |
| CC07FBL | 23.0 | 7 | 1.61 | 0.73 |
| CC10FBL | 32.8 | 10 | 2.2 | 1.0 |

● Not a standard certified product.

● Din Rail Mounting Bracket

Use when installing the driver on DIN Rail. See page [A-266] for more information.

Model name: **PADPO1**



HBL Series

This slim line motor and compact driver produces constant torque throughout its speed range of 300~2000 r/min.

The HBL series is suitable for smaller size applications.

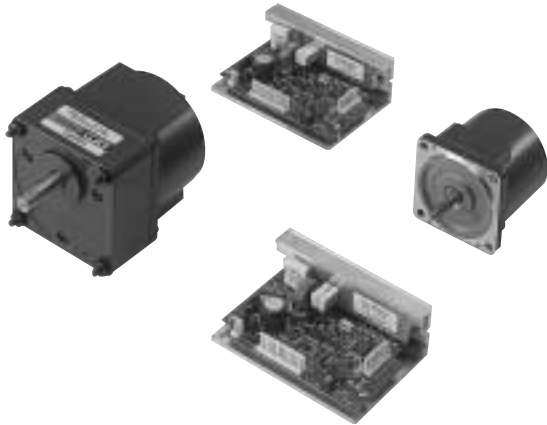

In the HBL series, a driver is provided with a motor as a package. (Gearhead shown in the picture is sold separately.)



■Features

- Compact board level driver is suitable for smaller sized applications.
- In addition to the “Overload protection” the HBL series also incorporates “Out-of-Phase protection.” In the event of a problem, the motor is brought to a stop and an alarm signal is output.
- To improve the reliability of feedback signals over longer distances, an optional extension cable is available. This increases the distance between the motor and driver to 16.4 ft. (5m)[60W, 100W] and 6.6 ft. (2m)[10W~40W]
- The motor features a compact design, enabling it to be installed in tight spaces.
- DC24V (DC48V) input makes it possible to switch to a backup power supply in the event of a power failure.
- Speed can be varied over a continuous range from 300 r/min to 2000 r/min with uniform torque throughout.
- The motor can be started, reversed and brought to an instantaneous stop using an electrical input control from the PLC.
- The pinion shaft model can be used with **GN** gearheads, thus enabling it to be combined with a wide range of gear ratios.
- For easy installation, 60W or 100W motors and gearhead come pre-assembled in the combination type.

■Product Number Code

HBL 5 40 K - GN

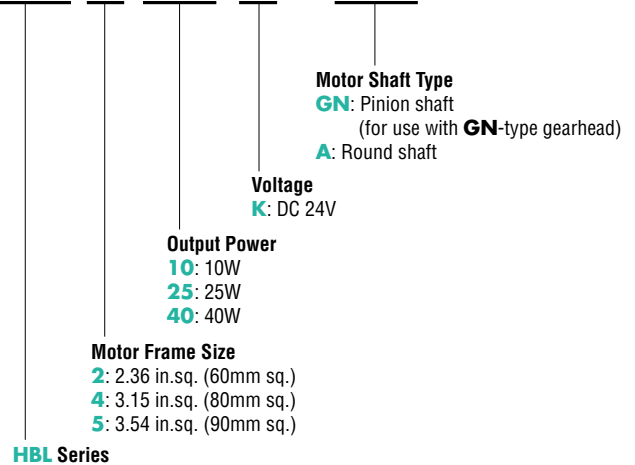

HBL 5 60 N - 5

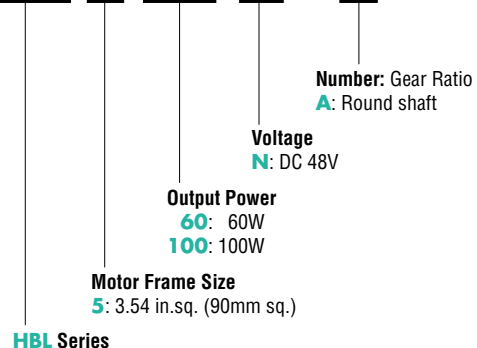

■ Type

● For 10W, 25W, 40W

| Output Power | | Pinion shaft type | Round shaft type |
|--------------|----|-------------------|-------------------|
| HP | W | | |
| 1/75 | 10 | HBL210K-GN | HBL210K-AA |
| 1/30 | 25 | HBL425K-GN | HBL425K-AA |
| 1/18.7 | 40 | HBL540K-GN | HBL540K-AA |

● When connecting gearheads, be sure to match the pinion shafts and frame sizes.

● GN Type Gearheads

| Model |
|-----------------------------------|
| 2GN3KA~2GN180KA |
| 2GN10XK (Decimal Gearhead) |
| 4GN3KA~4GN180KA |
| 4GN10XK (Decimal Gearhead) |
| 5GN3KA~5GN180KA |
| 5GN10XK (Decimal Gearhead) |

● For 60W, 100W Combination model type

| Output Power | | Model |
|--------------|------|------------------------|
| HP | W | |
| 1/12.4 | 60W | HBL560N-5~20 |
| | | HBL560N-30~100 |
| | | HBL560N-200 |
| 1/7.5 | 100W | HBL5100N-5~20 |
| | | HBL5100N-30~100 |
| | | HBL5100N-200 |

● For 60W, 100W Round shaft type

| Output Power | | Model |
|--------------|------|-------------------|
| HP | W | |
| 1/12.4 | 60W | HBL560N-A |
| 1/7.5 | 100W | HBL5100N-A |

■ Construction

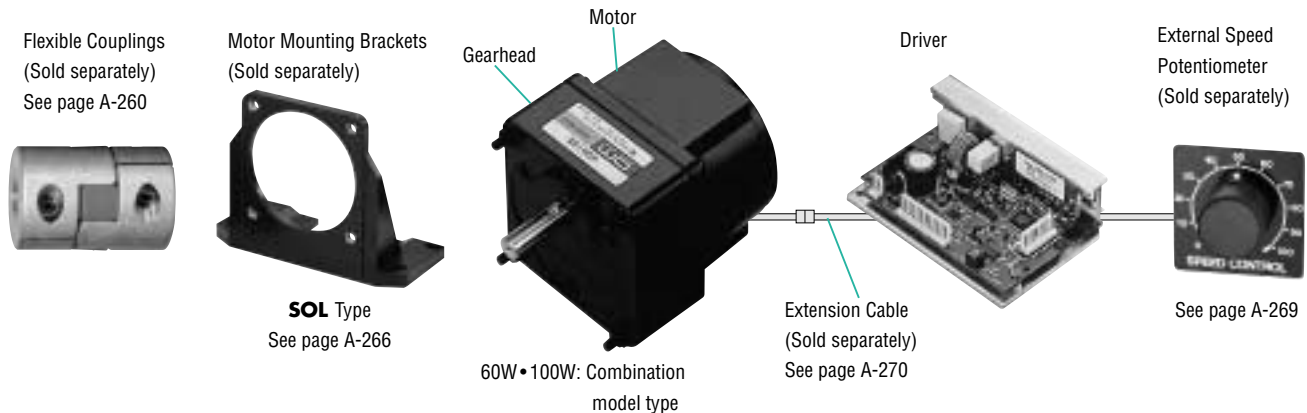

■ List of Motor and Driver Combinations

Model numbers for motor / driver combinations are shown below.

● For 10W, 25W, 40W Pinion shaft type

| Output Power | | Model | Motor Model | Driver Model |
|--------------|----|-------------------|-------------|--------------|
| HP | W | | | |
| 1/75 | 10 | HBL210K-GN | HBLM210K-GN | HBLD10K |
| 1/30 | 25 | HBL425K-GN | HBLM425K-GN | HBLD25K |
| 1/18 | 40 | HBL540K-GN | HBLM540K-GN | HBLD40K |

● For Round shaft type

| Output Power | | Model | Motor Model | Driver Model |
|--------------|-----|-------------------|-------------|--------------|
| HP | W | | | |
| 1/75 | 10 | HBL210K-AA | HBLM210K-AA | HBLD10K |
| 1/30 | 25 | HBL425K-AA | HBLM425K-AA | HBLD25K |
| 1/18.7 | 40 | HBL540K-AA | HBLM540K-AA | HBLD40K |
| 1/12.4 | 60 | HBL560N-A | HBLM560N-A | HBLD60N |
| 1/7.5 | 100 | HBL5100N-A | HBLM5100N-A | HBLD100N |

● For 60W, 100W Combination model type

| Output Power | | Model | Motor Model | Gearhead Model | Driver Model |
|--------------|-----|-------------------|---------------|----------------|--------------|
| HP | W | | | | |
| 1/12.4 | 60 | HBL560N-□ | HBLM560N-GFH | GFH5G□ | HBLD60N |
| 1/7.5 | 100 | HBL5100N-□ | HBLM5100N-GFH | GFH5G□ | HBLD100N |

● When connecting gearheads, be sure to match the pinion shafts and frame sizes.
● Enter the gear ratio in the box (□) within the model number.

■ Specifications

| Model | Pinion Shaft Type | | HBL210K-GN | HBL425K-GN | HBL540K-GN | HBL560N-□ | HBL5100N-□ | | | | | |
|---------------------------|--|--------------------|---|-------------------|---|------------------|----------------------|-----------|-----------------------|--------|----------------------|-------|
| | Round Shaft Type | | HBL210K-AA | HBL425K-AA | HBL540K-AA | HBL560N-A | HBL5100N-A | | | | | |
| Rated Speed | r/min | | 2000 | | | | | | | | | |
| Rated Output Power | HP | W | 1/75 | 10 | 1/30 | 25 | 1/18.7 | 40 | 1/12.4 | 60 | 1/7.5 | 100 |
| Rated Torque | oz-in | (N·m) | 6.9 | (0.05) | 17.4 | (0.125) | 27.8 | (0.2) | 41.6 | (0.3) | 69.4 | (0.5) |
| Starting Torque | oz-in | (N·m) | 8.3 | (0.06) | 20.8 | (0.15) | 33.3 | (0.24) | 50 | (0.36) | 83.3 | (0.6) |
| Permissible Inertial Load | J | kgm ² | 5×10 ⁻⁵ | | 1.8×10 ⁻⁴ | | 3.3×10 ⁻⁴ | | 3.75×10 ⁻⁴ | | 5.6×10 ⁻⁴ | |
| | | oz-in ² | 2.7 | | 9.8 | | 18 | | 20.5 | | 30.6 | |
| Variable Speed Range | r/min | | 300~2000 | | | | | | | | | |
| Input Power | Voltage | | DC24V±10% | | | | | DC48V±10% | | | | |
| | Current | | 2.0A | | 3.5A | | 4.5A | | 3A | | 5A | |
| Input Power for Signals | DC5V±5%, 100mA min. | | | | | | | | | | | |
| Speed Control Methods | 1. By built-in potentiometer 2. By external potentiometer 3. By DC voltage (0~5V DC) | | | | | | | | | | | |
| Speed Regulation | Load | | -3% Max. (0~rated torque, at 2000 r/min) | | | | | | | | | |
| | Voltage | | ±2% Max. (Power supply voltage DC24V±10%, at 2000 r/min with no load) | | | | | | | | | |
| | Temperature | | ±2% Max. (32°F~104°F / 0°C~+40°C, at 2000 r/min with no load) | | | | | | | | | |
| Input Signal | C-MOS level negative logic | | L (ON): 0~0.5V, | | H (OFF): 4~5V | | | | | | | |
| | START/STOP | | L: Start | | H: Stop | | | | | | | |
| | BRAKE | | L: Run | | H: Brake | | | | | | | |
| | Direction of Rotation | | L: CW | | H: CCW | | | | | | | |
| | Speed Potentiometer Selection | | L: Internal | | H: External (HBL560, 5100 Type) | | | | | | | |
| Output Signal | Open collector output External use condition: DC26.4V, 10mA max. SPEED, ALARM | | | | | | | | | | | |
| Protection Functions | When the following are activated, the alarm signal will be output and the motor will come to a stop: ● Overload Protection: This will be activated within approximately 5 seconds of the motor load exceeding rated torque. ● Out-of-Phase Protection: This will be activated when motor signals are abnormal, due to disconnection of cable, etc. | | | | | | | | | | | |
| Motor Insulation Class | Class E [248°F(120°C)] | | | | | | | | | | | |
| Rating | Continuous | | | | | | | | | | | |

Caution: HBL Series motors should not be used in gravitational applications in which they are driven by the load since doing so can cause the inverter's primary voltage to exceed the maximum limit and damage the driver.

■ General Specifications

| Item | Motor | Driver |
|------------------------------------|--|--|
| Insulation Resistance | 100MΩ or more when 500V DC is applied between the windings and the frame. | 100MΩ or more when 500V DC is applied between the FG and the power supply input terminal. |
| Dielectric Strength | Sufficient to withstand 0.5kV at 50Hz applied between the windings and the frame for 1 minute. | Sufficient to withstand 0.5kV at 50Hz applied between the FG and the power supply input terminal for 1 minute. |
| Operating Environmental Conditions | Ambient Temperature | 32°F~122°F (0~+50°C), nonfreezing |
| | Humidity | 85% maximum, noncondensing |
| | Atmosphere | No corrosive gases or dust |

■ Gearmotor — Torque Table

Unit = Upper values: lb-in / Lower values: N·m

| Model | Speed r/min | 100 | 83 | 60 | 50 | 40 | 33 | 24 | 20 | 17 | 12 | 10 | 8.3 | 6 | 5 | 4 | 3.3 | 3 | 2.5 | 2 | 1.7 |
|--------------------------|-------------|----------|------------|----------|----------|------------|----------|-------------|-----------|-----------|-----------|-----------|-----------|-----------|-----------|-----------|-----------|------------|------------|------------|------------|
| | | 667 | 556 | 400 | 333 | 267 | 222 | 160 | 133 | 111 | 80 | 67 | 56 | 40 | 33 | 27 | 22 | 20 | 17 | 13 | 11 |
| Gear Ratio | | 3 | 3.6 | 5 | 6 | 7.5 | 9 | 12.5 | 15 | 18 | 25 | 30 | 36 | 50 | 60 | 75 | 90 | 100 | 120 | 150 | 180 |
| HBL210K-GN/2GN□KA | 1 | 1.3 | 1.7 | 2.1 | 2.6 | 3.1 | 4.4 | 5.2 | 6.3 | 7.9 | 9.4 | 11 | 14 | 17 | 21 | 26 | 26 | 26 | 26 | 26 | 26 |
| | 0.12 | 0.15 | 0.2 | 0.24 | 0.3 | 0.36 | 0.51 | 0.61 | 0.73 | 0.91 | 1.1 | 1.3 | 1.7 | 2 | 2.5 | 3 | 3 | 3 | 3 | 3 | 3 |
| HBL425K-GN/4GN□KA | 2.6 | 3.2 | 4.4 | 5.3 | 6.6 | 7.9 | 11 | 13 | 16 | 20 | 24 | 29 | 36 | 43 | 54 | 65 | 69 | 69 | 69 | 69 | 69 |
| | 0.3 | 0.36 | 0.51 | 0.61 | 0.76 | 0.91 | 1.3 | 1.5 | 1.8 | 2.3 | 2.7 | 3.3 | 4.1 | 5 | 6.2 | 7.4 | 8 | 8 | 8 | 8 | 8 |
| HBL540K-GN/5GN□KA | 4.2 | 5.1 | 7 | 8.4 | 11 | 13 | 18 | 21 | 25 | 32 | 38 | 46 | 57 | 69 | 86 | 87 | 87 | 87 | 87 | 87 | 87 |
| | 0.49 | 0.58 | 0.81 | 0.97 | 1.2 | 1.5 | 2 | 2.4 | 2.9 | 3.7 | 4.4 | 5.3 | 6.6 | 7.9 | 9.9 | 10 | 10 | 10 | 10 | 10 | 10 |

- Enter the gear ratio in the box (□) within the model number.
- A colored background indicates gear shaft rotation in the same direction as the motor shaft; a white background indicates rotation in the opposite direction.

Unit = Upper values: lb-in / Lower values: N·m

| Model | Gear Ratio | 5 | 10 | 15 | 20 | 30 | 50 | 100 | 200 |
|-------------------|------------|-------------|-----------|-----------|-----------|-----------|-----------|------------|------------|
| | | Speed r/min | 60~400 | 30~200 | 20~133 | 15~100 | 10~67 | 6~40 | 3~20 |
| HBL560N-□ | 12 | 23 | 35 | 47 | 67 | 112 | 224 | 260 | |
| | 1.4 | 2.7 | 4.1 | 5.4 | 7.7 | 13 | 26 | 30 | |
| HBL5100N-□ | 20 | 39 | 59 | 78 | 112 | 187 | 260 | 260 | |
| | 2.3 | 4.5 | 6.8 | 9 | 13 | 22 | 30 | 30 | |

- Enter the gear ratio in the box (□) within the model number.
- A colored background indicates gear shaft rotation in the same direction as the motor shaft; a white background indicates rotation in the opposite direction.

■ Permissible Overhung Load and Permissible Thrust Load

| Gearhead Model | Gear Ratio | Permissible Overhung Load | | Permissible Thrust Load | |
|-------------------|---------------|---------------------------|-------|-------------------------|-------|
| | | lb | (N) | lb | (N) |
| 2GN□KA | 3~18 | 11 | (50) | 6.7 | (30) |
| | 25~180 | 26 | (120) | | |
| 4GN□KA | 3~18 | 22 | (100) | 11 | (50) |
| | 25~180 | 44 | (200) | | |
| 5GN□KA | 3~18 | 55 | (250) | 22 | (100) |
| | 25~180 | 66 | (300) | | |
| HBL560N-□ | 5 | 66 | (300) | 33 | (150) |
| HBL5100N-□ | 10~20 | 88 | (400) | | |
| | 30~200 | 110 | (500) | | |

- Enter the gear ratio in the box (□) within the model number.

■ Permissible Inertial Load (J)

Unit = Upper values: lb-in² / Lower values: ×10⁻⁴kgm²

| Model | Gear Ratio | 3 | 3.6 | 5 | 6 | 7.5 | 9 | 12.5 | 15 | 18 | 25 | 30 | 36 | 50 | 60 | 75 | 90 | 100 | 120 | 150 | 180 |
|--------------------------|------------|--------------------------|------------|----------|----------|------------|----------|-------------|-----------|-----------|-----------|-----------|-----------|-----------|-----------|-----------|-----------|------------|------------|------------|------------|
| | | HBL210K-GN/2GN□KA | 0.189 | 0.272 | 0.525 | 0.756 | 1.18 | 1.7 | 3.28 | 4.73 | 6.8 | 13.1 | 18.9 | 27.2 | 52.5 | 52.5 | 52.5 | 52.5 | 52.5 | 52.5 | 52.5 |
| HBL425K-GN/4GN□KA | 0.684 | 0.985 | 1.9 | 2.74 | 4.28 | 6.16 | 11.9 | 17.1 | 24.6 | 47.5 | 68.4 | 98.5 | 190 | 190 | 190 | 190 | 190 | 190 | 190 | 190 | 190 |
| HBL540K-GN/5GN□KA | 1.17 | 1.68 | 3.25 | 4.68 | 7.31 | 10.5 | 20.3 | 29.3 | 42.1 | 81.3 | 117 | 168 | 325 | 325 | 325 | 325 | 325 | 325 | 325 | 325 | 325 |
| | 3.6 | 5.18 | 10 | 14.4 | 22.5 | 32.4 | 62.5 | 90 | 130 | 250 | 360 | 518 | 1000 | 1000 | 1000 | 1000 | 1000 | 1000 | 1000 | 1000 | 1000 |

| Model | Gear Ratio | 5 | 10 | 15 | 20 | 30 | 50 | 100 | 200 |
|-------------------|------------|----------|-----------|-----------|-----------|-----------|-----------|------------|------------|
| HBL560N-□ | | 8.5 | 34 | 76.5 | 136 | 306 | 850 | 850 | 850 |
| HBL5100N-□ | | 25 | 100 | 225 | 400 | 900 | 2500 | 2500 | 2500 |

- Enter the gear ratio in the box (□) within the model number.

■ Torque-Speed Characteristics

● Continuous Duty Region

Continuous operation is possible in this region.

● Limited Duty Region

This region is used primarily when accelerating. When a load that exceeds the rated torque is applied continuously for approximately 5 seconds, overload protection is activated and the motor comes to stop.

HBL210K-GN
HBL210K-AA

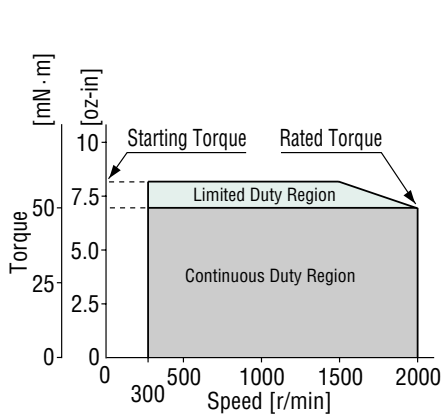

HBL425K-GN
HBL425K-AA

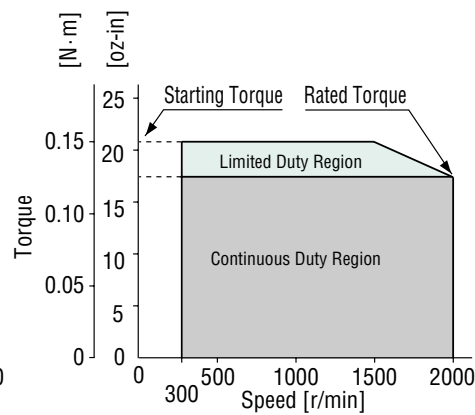

HBL540K-GN
HBL540K-AA

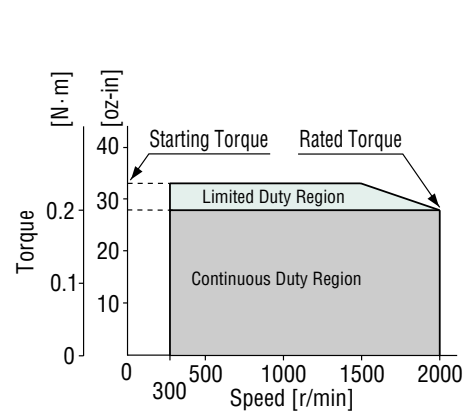

HBL560N-□
HBL560N-A

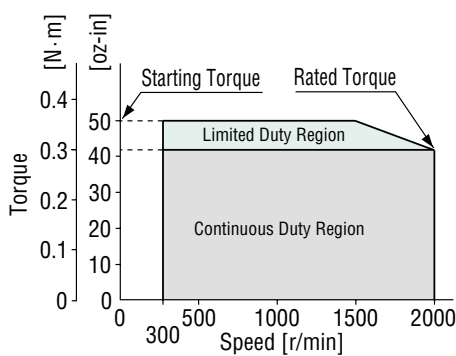

HBL5100N-□
HBL5100N-A

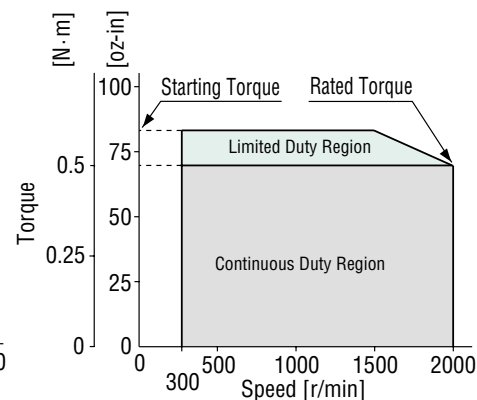

* The combination type is the value for the motor alone.

■ Wiring Diagrams

● HBL210, HBL425, HBL540

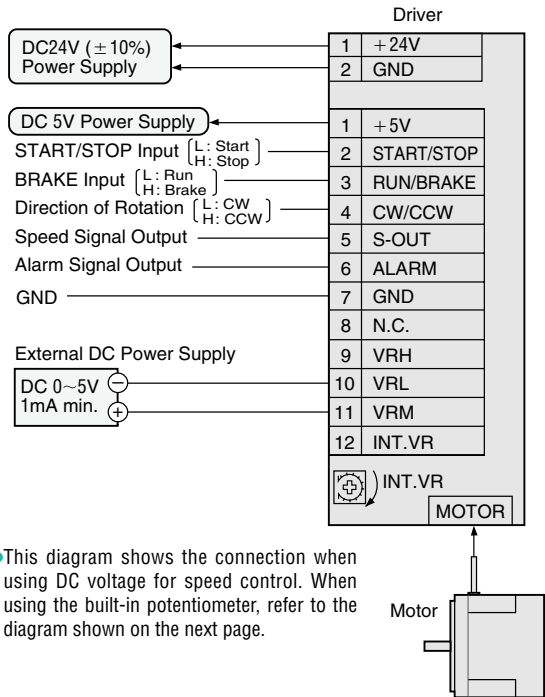

● HBL560, HBL5100

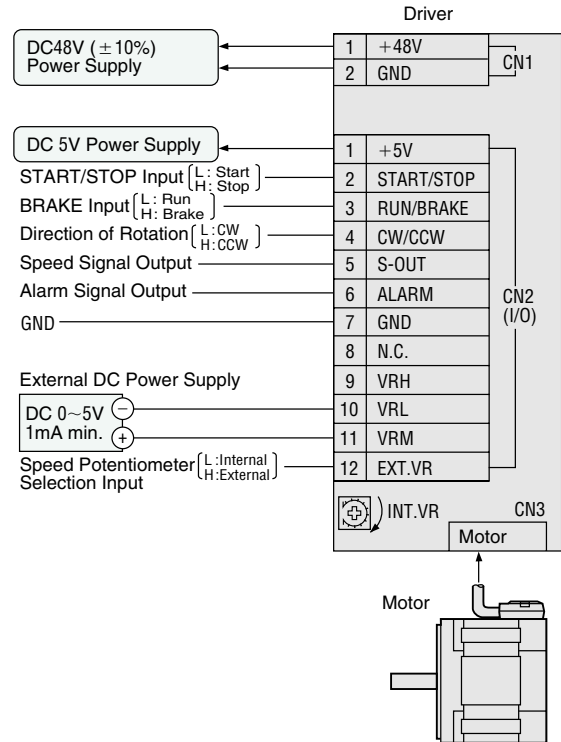

■ Signal Input Timing Chart

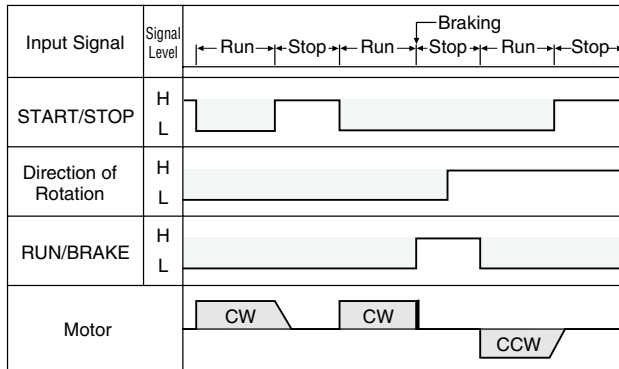

● RUN/BRAKE

The brake input runs or stops the motor when START/STOP input has been set to "L" level, the motor rotates at the speed selected; if set to "H" level, the motor stops instantaneously.

● Direction of Rotation

The direction of rotation can be changed by the direction of rotation input. The diagram shows the direction of motor shaft rotation as viewed from the motor shaft.

■ Control by Small Capacity Relays or Switches

● HBL210, HBL425, HBL540

Switch Capacity: DC24V 10mA

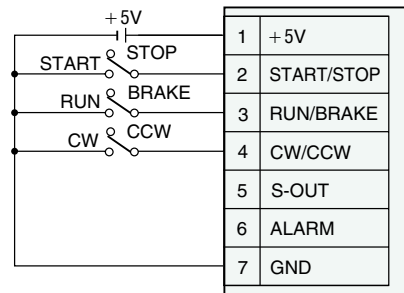

● HBL560, HBL5100

Switch Capacity: DC24V 10mA

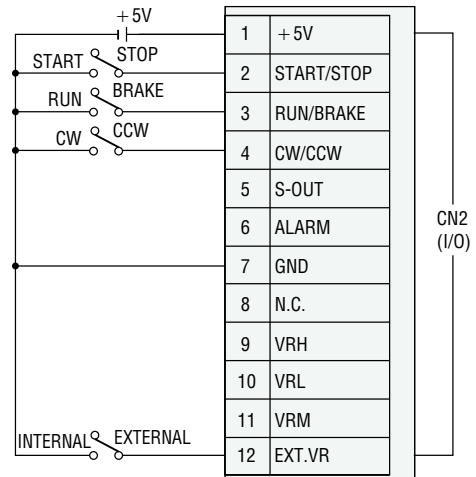

■ Speed Control

① Speed Control by Built-in Potentiometer

● HBL210, HBL425, HBL540

Connect terminals 11 and 12, and turn the potentiometer clockwise to increase the speed.

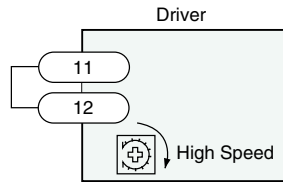

● HBL560, HBL5100

The EXT, VR input has been set to OFF ("L"Level), and turn the potentiometer clockwise to increase the speed.

② Speed Control by External Potentiometer

To control the speed of the motor when it is separated from the driver, connect the external potentiometer provided with the motor as follows.

External Potentiometer **PAVR-20KY** (Sold separately)

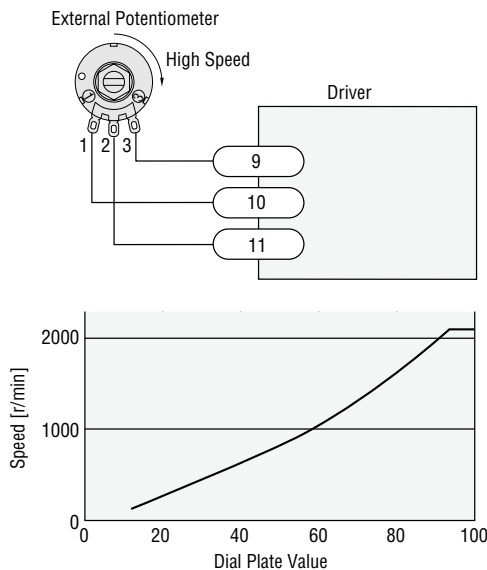

③ Speed Control by DC Voltage

To control the speed of the motor by DC voltage, connect the DC power supply as follows.

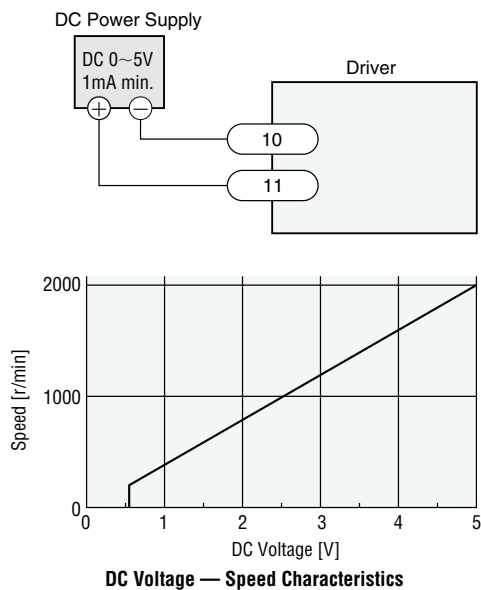

■ Connection of Output Signals

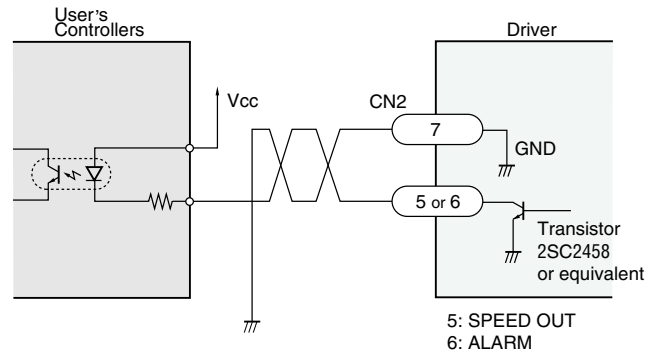

Speed Signal Output:

It is output at a rate of 12 pulses per motor rotation. Motor speed can be determined using the following formula:

$$\text{Motor speed} = \frac{\text{Speed output frequency [Hz]}}{12} \times 60 [\text{r/min}]$$

Alarm Signal Output:

This signal is output when protection for overload or out-of-phase has been activated.

Note:

- Signal output is done through an open collector transistor which requires an external power source.
- The external power source should be less than DC 26.4V. The transistor in the driver requires less than 10mA.

■ Dimensions Scale 1/4, Unit = inch (mm)

HBL210K-GN (Pinion Shaft Type)

Motor: HBLM210K-GN Weight (Mass): 1.32 lb. (0.6 kg) /

Driver: HBLD10K

Gearhead: **2GN□KA** Weight (Mass): 0.88 lb. (0.4 kg)

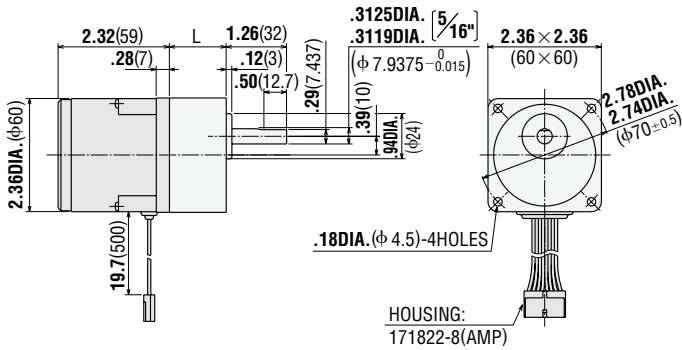

$L = 1.18$ (30) **2GN3KA~18KA**

$L = 1.57$ (40) **2GN25KA~180KA**

HBL210K-AA (Round Shaft Type)

Motor: HBLM210K-AA Weight (Mass): 1.32 lb. (0.6 kg)

Driver: HBLD10K

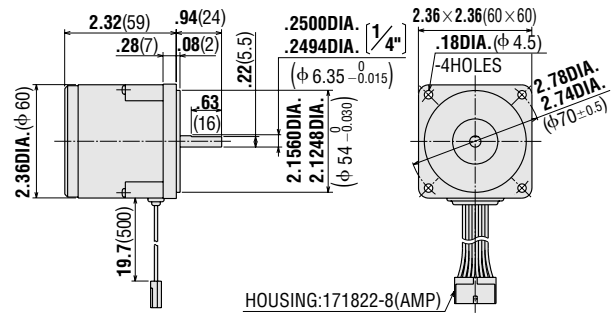

HBL425K-GN (Pinion Shaft Type)

Motor: HBLM425K-GN Weight (Mass): 2.2 lb. (1.0 kg) /

Driver: HBLD25K

Gearhead: **4GN□KA** Weight (Mass): 1.32 lb. (0.6 kg)

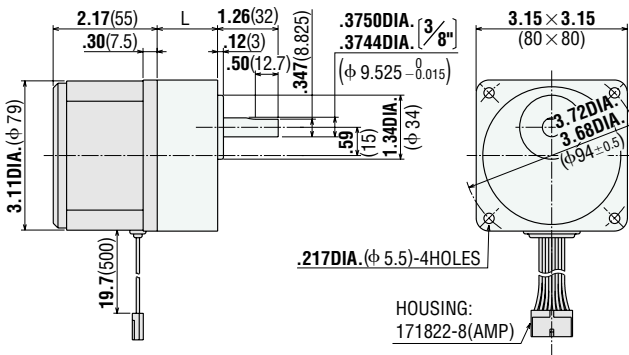

$L = 1.26$ (32) **4GN3KA~18KA**

$L = 1.67$ (42.5) **4GN25KA~180KA**

HBL425K-AA (Round Shaft Type)

Motor: HBLM425K-AA Weight (Mass): 2.2 lb. (1.0 kg)

Driver: HBLD25K

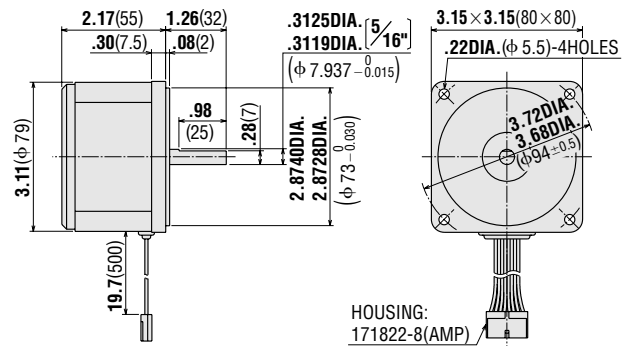

HBL540K-GN (Pinion Shaft Type)

Motor: HBLM540K-GN Weight (Mass): 2.9 lb. (1.3 kg) /

Driver: HBLD40K

Gearhead: **5GN□KA** Weight (Mass): 3.3 lb. (1.5 kg)

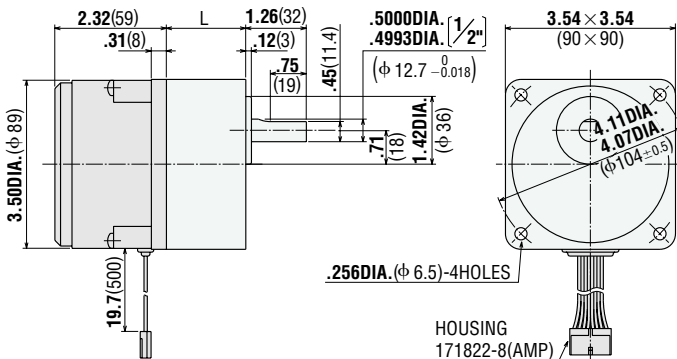

$L = 1.65$ (42) **5GN3KA~18KA**

$L = 2.36$ (60) **5GN25KA~180KA**

HBL540K-AA (Round Shaft Type)

Motor: HBLM540K-AA Weight (Mass): 2.9 lb. (1.3 kg)

Driver: HBLD40K

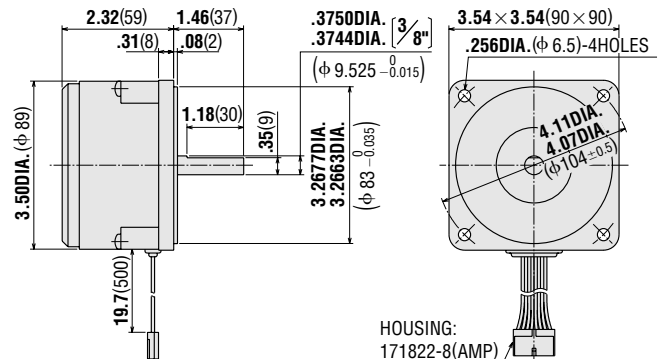

●HBL560N- (Combination Model)
 Motor: HBLM560N-GFH /Gearhead: GFH5G
 Driver: HBLD60N
 Weight (Mass): 6.6 lb. (3.0kg)

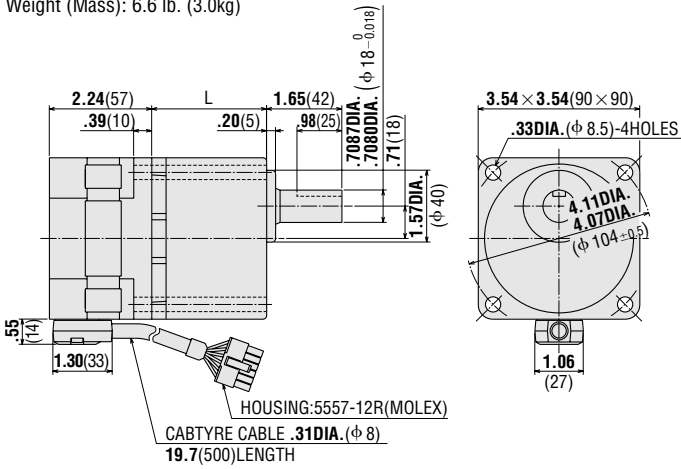

L = 1.77 (45) **HBL560N-5~20**
 L = 2.28 (58) **HBL560N-30~100**
 L = 2.52 (64) **HBL560N-200**

●HBL560N-A (Round Shaft Type)
 Motor: HBLM560N-A
 Driver: HBLD60N
 Weight (Mass): 3.3 lb. (1.5kg)

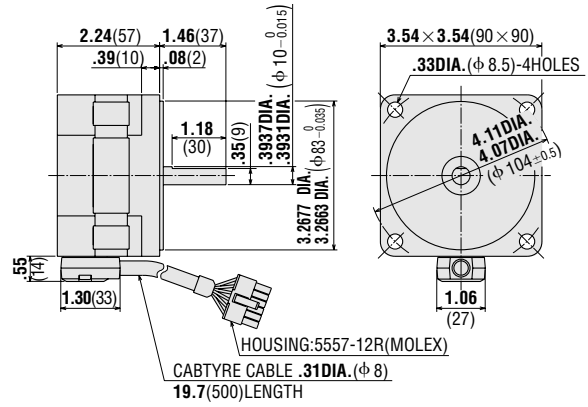

●HBL5100N- (Combination Model)
 Motor: HBLM5100N-GFH /Gearhead: GFH5G
 Driver: HBLD100N
 Weight (Mass): 8.8 lb. (4.0kg)

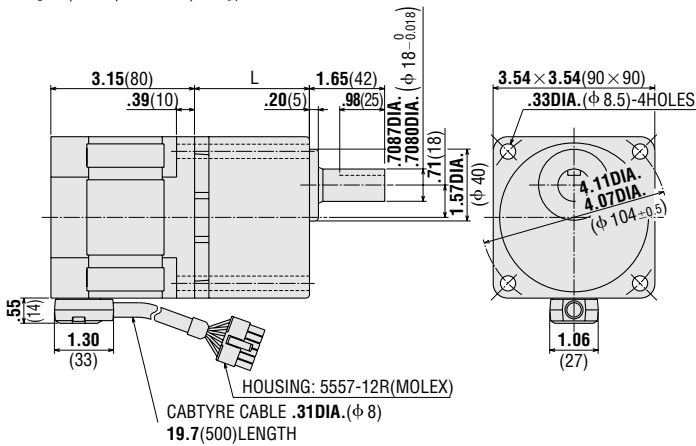

L = 1.77 (45) **HBL5100N-5~20**
 L = 2.28 (58) **HBL5100N-30~100**
 L = 2.52 (64) **HBL5100N-200**

●HBL5100N-A (Round Shaft Type)
 Motor: HBLM5100N-A
 Driver: HBLD100N
 Weight (Mass): 5.5 lb. (2.5kg)

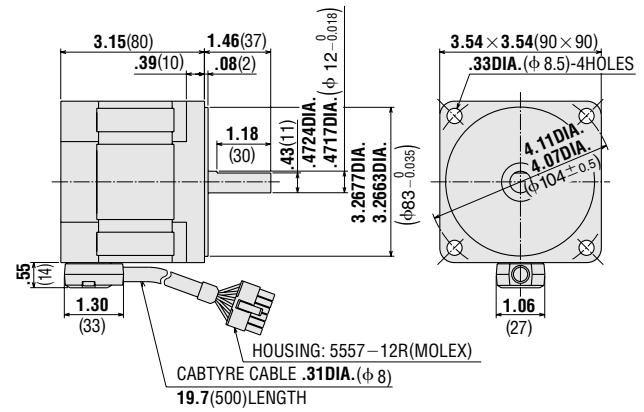

●Key and Key Slot

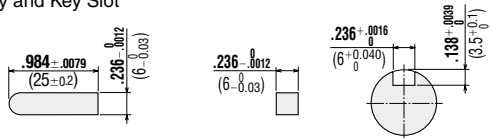

●Driver

HBLD10K, HBLD25K, HBLD40K
 Weight (Mass): 0.4 lb. (0.2kg)

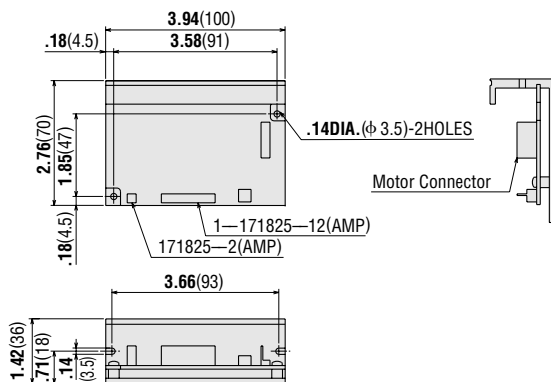

HBLD60N, HBLD100N
 Weight (Mass): 0.5 lb. (0.24kg)

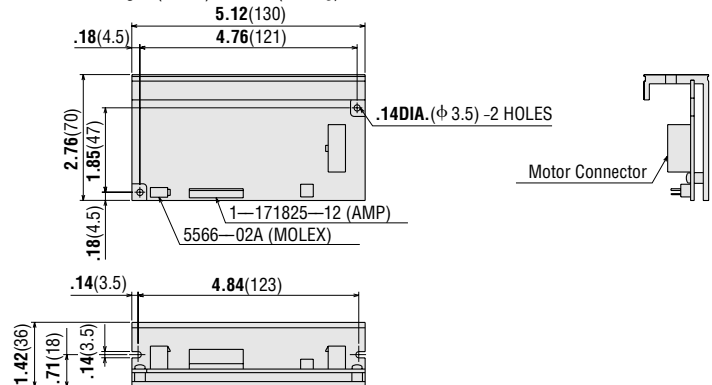

● Input Signal Cable (included)

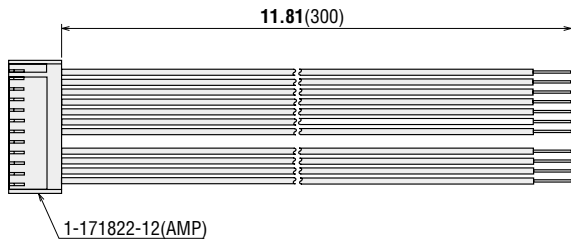

● Power Supply Cable (included)
HBL210, HBL425, HBL540

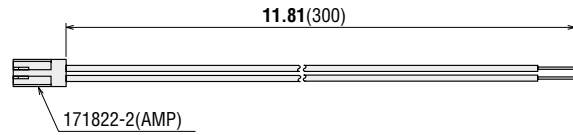

HBL560, HBL5100

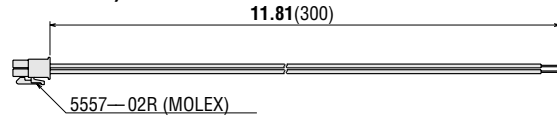

■ Accessories (sold separately)

● Extension Cable

● **HBL210, HBL425, HBL540** (Motor model)
FC02HBL (Cable model)

Using the extension cable allows the motor and driver to be separated by up to 6.6 ft. (2m)

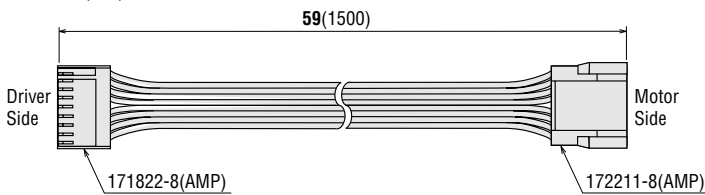

● **HBL560, HBL5100** (Motor model)

Using the extension cable allows the motor and driver to be separated by up to 18 ft. (5.5m)

| Cable Model | Length | |
|----------------|--------|---|
| | ft. | m |
| CC01FBL | 3.3 | 1 |
| CC02FBL | 6.6 | 2 |
| CC03FBL | 9.8 | 3 |
| CC05FBL | 16.4 | 5 |

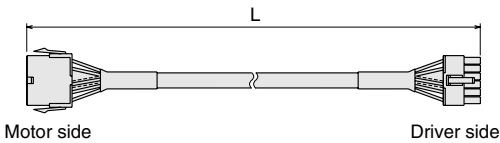

● Motor Mounting Brackets



Optional die-cast aluminum mounting brackets are available. They can be used to install motors without gearheads. See page A-266 for more information.

| Motor Model | Mounting Bracket |
|----------------|------------------|
| HBL210 | SOL2U08 |
| HBL425 | SOL4U10 |
| HBL540 | SOL5UA |
| HBL560 | SOL5M8 |
| HBL5100 | |

● Flexible couplings

Optional flexible couplings are available. See page [A-260] for more information.



● External Speed Potentiometer

PAVR-20KY



● Dimensions Weight (Mass): 0.08 lb. (35g)

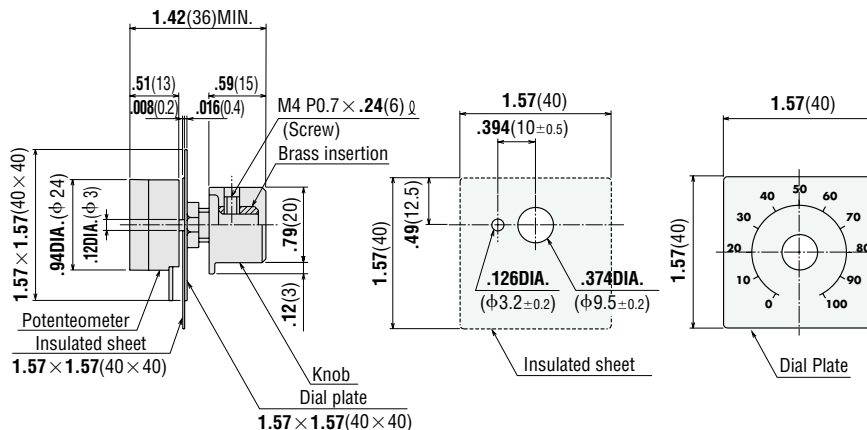

Component Package Type Speed Control Motor Unit

SC Series

This speed control unit allows speed control and acceleration/deceleration operation in combination with speed control motors with an output power of 6W~60W. The control packs can be directly mounted on the control board.

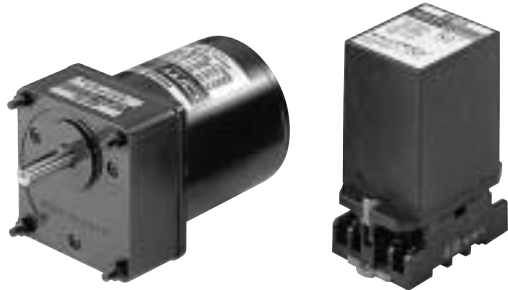

• The gearhead in the photograph is sold separately.



Product Number Code

SC 4 25 -4 0 1W U

Provided Capacitor
U: 110V/115V
E: 220V/230V

Voltage
1W: Single-Phase 110V/115V
2W: Single-Phase 220V/230V

Motor Type
O: Induction Motor (Continuous Rating)
T: Reversible Motor (30 Minute Rating)

Shaft Type
O: Round Shaft
4: GN type pinion shaft
5: GU type pinion shaft

Output Power
06: 6W **40:** 40W
15: 15W **60:** 60W
25: 25W

Motor Frame Size
2: 2.36 in.sq.(60mm sq.)
3: 2.76 in.sq.(70mm sq.)
4: 3.15 in.sq.(80mm sq.)
5: 3.54 in.sq.(90mm sq.)

SC series Speed Control Motor Unit

Note : The "U" and "E" at the end of the model number indicate that the unit includes a capacitor. These two letters are not listed on the motor nameplate.

Features

- Speed Range: 90 r/min~1400 r/min (50Hz), 90 r/min~1600 r/min (60Hz)
- Connection is simplified by a compact plug-in construction (11 pins).
- The control packs have an acceleration/deceleration function that enables smooth starts and stops. Setting and adjustment are easy since they have a built-in timing potentiometer for acceleration time and deceleration time.
- Multiple motors can be operated by a single speed potentiometer.
- Compatible with voltages in all major countries.
- The design conforms to typical global safety standards.
- The CE Marking is used in accordance with the low voltage directive.

Safety Standards and CE Marking

Approved Standards

| Motor | | | |
|--|--|---|-----------------------|
| Standards | Certification Body | Standards File No. | CE Marking |
| UL1004 UL519 (SC206 type) UL547 (SC315, SC425, SC540, SC560 type) CAN/CSA-C22.2 No.100 CAN/CSA-C22.2 No.77 | UL | E64199 (SC206 type) E64197 (SC315, US425, SC540, SC560 type) | Low voltage Directive |
| EN60950 | VDE | 114919UG (SC206 type) 6751UG (SC315, SC425, SC540, SC560 type) | |
| EN60034-1 EN60034-5 IEC60034-11 | Conform to EN/IEC Standards (EN/IEC certifications are scheduled.) | | |
| Speed control pack | | | |
| Standards | Certification Body | Standards File No. | CE Marking |
| UL508 CAN/CSA-C22.2 No.14 EN60950 DIN VDE 0160 | UL TÜV Rheinland | E91291 R9551853 | Low voltage Directive |

- Note :**
- Each component is recognized individually and as a package.
 - The EMC measurements required under standard DIN VDE 0160 are not performed for motors and speed control packs. Perform the EMC test when they are incorporated into the final product.
 - The over-voltage protection test required under standard DIN VDE 0160 is not performed. Perform the test when incorporated into the final product.
 - For installations for EN/IEC standards, see page D-2.

■ Type

● Induction Motor Single-Phase 110V/115V

| Output Power | | Model | |
|--------------|------|--------------------|--------------------|
| HP | (W) | Pinion shaft | Round shaft |
| 1/124 | (6) | SC206-401WU | SC206-001WU |
| 1/50 | (15) | SC315-401WU | SC315-001WU |
| 1/30 | (25) | SC425-401WU | SC425-001WU |
| 1/18.5 | (40) | SC540-401WU | SC540-001WU |
| 1/12.5 | (60) | SC560-501WU | SC560-001WU |

● Induction Motor Single-Phase 220V/230V

| Output Power | | Model | |
|--------------|------|--------------------|--------------------|
| HP | (W) | Pinion shaft | Round shaft |
| 1/124 | (6) | SC206-402WE | SC206-002WE |
| 1/50 | (15) | SC315-402WE | SC315-002WE |
| 1/30 | (25) | SC425-402WE | SC425-002WE |
| 1/18.5 | (40) | SC540-402WE | SC540-002WE |
| 1/12.5 | (60) | SC560-502WE | SC560-002WE |

● Gearheads

| Motor Model | Gearhead Model |
|--------------|--|
| SC206 | 2GN3KA ~ 2GN180KA 2GN10XK (Decimal Gearhead) |
| SC315 | 3GN3KA ~ 3GN180K 3GN10XK (Decimal Gearhead) |
| SC425 | 4GN3KA ~ 4GN180KA 4GN10XK (Decimal Gearhead) |
| SC540 | 5GN3KA ~ 5GN180KA 5GN10XK (Decimal Gearhead) |
| SC560 | 5GU3KA ~ 5GU180KA 5GU10XKB (Decimal Gearhead) |

● Reversible Motor Single-Phase 110V/115V

| Output Power | | Model | |
|--------------|------|--------------------|--------------------|
| HP | (W) | Pinion shaft | Round shaft |
| 1/124 | (6) | SC206-411WU | SC206-011WU |
| 1/50 | (15) | SC315-411WU | SC315-011WU |
| 1/30 | (25) | SC425-411WU | SC425-011WU |
| 1/18.5 | (40) | SC540-411WU | SC540-011WU |
| 1/12.5 | (60) | SC560-511WU | SC560-011WU |

● Reversible Motor Single-Phase 220V/230V

| Output Power | | Model | |
|--------------|------|--------------------|--------------------|
| HP | (W) | Pinion shaft | Round shaft |
| 1/124 | (6) | SC206-412WE | SC206-012WE |
| 1/50 | (15) | SC315-412WE | SC315-012WE |
| 1/30 | (25) | SC425-412WE | SC425-012WE |
| 1/18.5 | (40) | SC540-412WE | SC540-012WE |
| 1/12.5 | (60) | SC560-512WE | SC560-012WE |

■ Construction

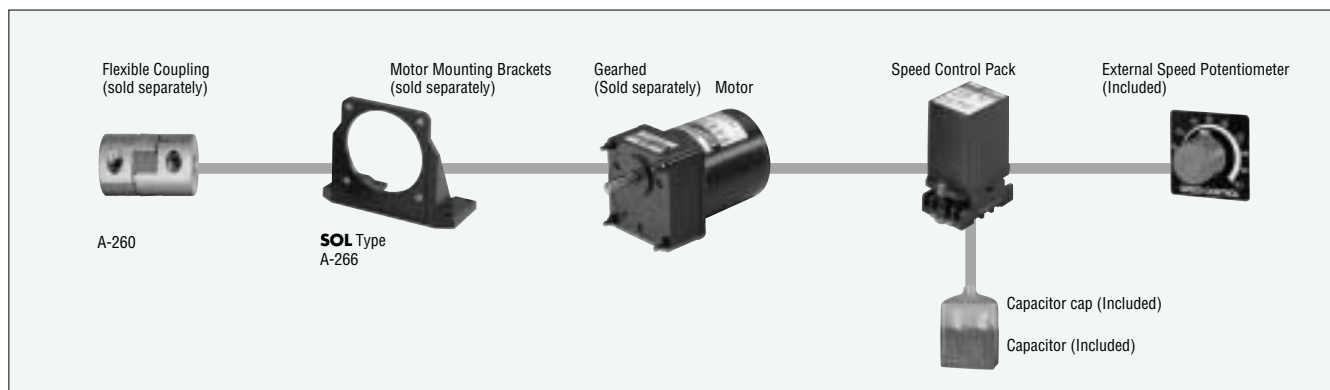

■ Specifications

● Induction Motors – Continuous Rating



| Unit Model | | Maximum Output Power HP W | Voltage V | Frequency Hz | Speed Range r/min | Permissible Torque | | | | Starting Torque Current | | Power Consumption W | Capacitor μF |
|-------------------|------------------|------------------------------|-----------------|-----------------|----------------------|--------------------|----------|-------|------|-------------------------|------|------------------------|-----------------|
| Pinion Shaft Type | Round Shaft Type | | | | | 1200 r/min | 90 r/min | oz-in | mN·m | oz-in | mN·m | | |
| ZP | SC206-401WU | 1/124 6 | Single-Phase110 | 60 | 90~1600 | 6.9 | 50 | 4.2 | 30 | 4.9 | 35 | 0.26 | 24 |
| | | | Single-Phase115 | 60 | 90~1600 | 6.9 | 50 | 4.2 | 30 | 4.9 | 35 | 0.29 | 29 |
| TP | SC315-401WU | 1/50 15 | Single-Phase110 | 60 | 90~1600 | 17.4 | 125 | 4.2 | 30 | 7.6 | 55 | 0.50 | 46 |
| | | | Single-Phase115 | 60 | 90~1600 | 17.4 | 125 | 4.7 | 34 | 9.0 | 65 | 0.51 | 48 |
| TP | SC425-401WU | 1/30 25 | Single-Phase110 | 60 | 90~1600 | 20.1 | 145 | 5.6 | 40 | 12.5 | 90 | 0.72 | 65 |
| | | | Single-Phase115 | 60 | 90~1600 | 22.2 | 160 | 6.0 | 43 | 13.9 | 100 | 0.74 | 67 |
| TP | SC540-401WU | 1/18.5 40 | Single-Phase110 | 60 | 90~1600 | 31.9 | 230 | 7.6 | 55 | 22.2 | 160 | 1.1 | 101 |
| | | | Single-Phase115 | 60 | 90~1600 | 44.4 | 320 | 7.6 | 55 | 23.6 | 170 | 1.1 | 103 |
| TP | SC560-501WU | 1/12.5 60 | Single-Phase110 | 60 | 90~1600 | 54.2 | 390 | 13.2 | 95 | 45.8 | 330 | 1.60 | 160 |
| | | | Single-Phase115 | 60 | 90~1600 | 54.2 | 390 | 13.2 | 95 | 48.6 | 350 | 1.60 | 160 |
| ZP | SC206-402WE | 1/124 6 | Single-Phase220 | 60 | 90~1600 | 6.9 | 50 | 4.2 | 30 | 4.2 | 30 | 0.14 | 29 |
| | | | Single-Phase230 | 50 | 90~1400 | 6.9 | 50 | 4.2 | 30 | 4.9 | 35 | 0.14 | 30 |
| | | | Single-Phase230 | 60 | 90~1600 | 6.9 | 50 | 4.2 | 30 | 4.9 | 35 | 0.14 | 30 |
| TP | SC315-402WE | 1/50 15 | Single-Phase220 | 60 | 90~1600 | 15.3 | 110 | 4.2 | 30 | 8.1 | 58 | 0.23 | 44 |
| | | | Single-Phase230 | 50 | 90~1400 | 17.4 | 125 | 4.7 | 34 | 9.0 | 65 | 0.23 | 44 |
| | | | Single-Phase230 | 60 | 90~1600 | 17.4 | 125 | 4.7 | 34 | 9.0 | 65 | 0.23 | 47 |
| TP | SC425-402WE | 1/30 25 | Single-Phase220 | 60 | 90~1600 | 20.1 | 145 | 5.6 | 40 | 13.9 | 100 | 0.35 | 65 |
| | | | Single-Phase230 | 50 | 90~1400 | 28.5 | 205 | 6.0 | 43 | 15.3 | 110 | 0.34 | 61 |
| | | | Single-Phase230 | 60 | 90~1600 | 22.2 | 160 | 6.0 | 43 | 15.3 | 110 | 0.35 | 65 |
| TP | SC540-402WE | 1/18.5 40 | Single-Phase220 | 60 | 90~1600 | 31.9 | 230 | 8.3 | 60 | 25.0 | 180 | 0.55 | 97 |
| | | | Single-Phase230 | 50 | 90~1400 | 44.4 | 320 | 9.0 | 65 | 27.8 | 200 | 0.55 | 92 |
| | | | Single-Phase230 | 60 | 90~1600 | 33.3 | 240 | 9.0 | 65 | 27.8 | 200 | 0.56 | 98 |
| TP | SC560-502WE | 1/12.5 60 | Single-Phase220 | 60 | 90~1600 | 68.0 | 490 | 25.0 | 180 | 44.4 | 320 | 0.92 | 180 |
| | | | Single-Phase230 | 50 | 90~1400 | 68.0 | 490 | 26.4 | 190 | 48.6 | 350 | 0.98 | 186 |
| | | | Single-Phase230 | 60 | 90~1600 | 68.0 | 490 | 26.4 | 190 | 48.6 | 350 | 0.93 | 186 |

● Reversible Motors – 30 Minutes Rating



| Unit Model | | Maximum Output Power HP W | Voltage V | Frequency Hz | Speed Range r/min | Permissible Torque | | | | Starting Torque Current | | Power Consumption W | Capacitor μF |
|-------------------|------------------|------------------------------|-----------------|-----------------|----------------------|--------------------|----------|-------|------|-------------------------|------|------------------------|-----------------|
| Pinion Shaft Type | Round Shaft Type | | | | | 1200 r/min | 90 r/min | oz-in | mN·m | oz-in | mN·m | | |
| ZP | SC206-411WU | 1/124 6 | Single-Phase110 | 60 | 90~1600 | 6.9 | 50 | 6.9 | 50 | 5.6 | 40 | 0.32 | 31 |
| | | | Single-Phase115 | 60 | 90~1600 | 6.9 | 50 | 6.9 | 50 | 6.2 | 45 | 0.32 | 31 |
| TP | SC315-411WU | 1/50 15 | Single-Phase110 | 60 | 90~1600 | 17.4 | 125 | 9.7 | 70 | 10.4 | 75 | 0.58 | 56 |
| | | | Single-Phase115 | 60 | 90~1600 | 17.4 | 125 | 9.7 | 70 | 11.8 | 85 | 0.58 | 56 |
| TP | SC425-411WU | 1/30 25 | Single-Phase110 | 60 | 90~1600 | 28.5 | 205 | 13.2 | 95 | 13.9 | 100 | 0.93 | 90 |
| | | | Single-Phase115 | 60 | 90~1600 | 28.5 | 205 | 13.2 | 95 | 15.3 | 110 | 0.93 | 90 |
| TP | SC540-411WU | 1/18.5 40 | Single-Phase110 | 60 | 90~1600 | 44.4 | 320 | 18.1 | 130 | 27.8 | 200 | 1.4 | 131 |
| | | | Single-Phase115 | 60 | 90~1600 | 44.4 | 320 | 18.1 | 130 | 29.2 | 210 | 1.4 | 133 |
| TP | SC560-511WU | 1/12.5 60 | Single-Phase110 | 60 | 90~1600 | 55.5 | 400 | 16.7 | 120 | 44.4 | 320 | 1.70 | 160 |
| | | | Single-Phase115 | 60 | 90~1600 | 55.5 | 400 | 16.7 | 120 | 50.0 | 360 | 1.70 | 170 |
| ZP | SC206-412WE | 1/124 6 | Single-Phase220 | 60 | 90~1600 | 6.9 | 50 | 6.9 | 50 | 5.3 | 38 | 0.16 | 30 |
| | | | Single-Phase230 | 50 | 90~1400 | 6.9 | 50 | 6.9 | 50 | 6.2 | 45 | 0.16 | 33 |
| | | | Single-Phase230 | 60 | 90~1600 | 6.9 | 50 | 6.9 | 50 | 6.0 | 43 | 0.16 | 33 |
| TP | SC315-412WE | 1/50 15 | Single-Phase220 | 60 | 90~1600 | 17.4 | 125 | 9.7 | 70 | 12.5 | 90 | 0.29 | 53 |
| | | | Single-Phase230 | 50 | 90~1400 | 17.4 | 125 | 9.7 | 70 | 13.9 | 100 | 0.3 | 63 |
| | | | Single-Phase230 | 60 | 90~1600 | 17.4 | 125 | 9.7 | 70 | 13.9 | 100 | 0.29 | 53 |
| TP | SC425-412WE | 1/30 25 | Single-Phase220 | 60 | 90~1600 | 28.5 | 205 | 13.2 | 95 | 18.1 | 130 | 0.44 | 84 |
| | | | Single-Phase230 | 50 | 90~1400 | 28.5 | 205 | 13.2 | 95 | 20.8 | 150 | 0.44 | 82 |
| | | | Single-Phase230 | 60 | 90~1600 | 28.5 | 205 | 13.2 | 95 | 19.4 | 140 | 0.44 | 86 |
| TP | SC540-412WE | 1/18.5 40 | Single-Phase220 | 60 | 90~1600 | 44.4 | 320 | 19.4 | 140 | 36.1 | 260 | 0.73 | 129 |
| | | | Single-Phase230 | 50 | 90~1400 | 44.4 | 320 | 18.1 | 130 | 41.7 | 300 | 0.71 | 120 |
| | | | Single-Phase230 | 60 | 90~1600 | 44.4 | 320 | 19.4 | 140 | 40.3 | 290 | 0.73 | 129 |
| TP | SC560-512WE | 1/12.5 60 | Single-Phase220 | 60 | 90~1600 | 68.0 | 490 | 31.9 | 230 | 50.0 | 360 | 1.1 | 215 |
| | | | Single-Phase230 | 50 | 90~1400 | 68.0 | 490 | 30.6 | 220 | 56.9 | 410 | 1.1 | 205 |
| | | | Single-Phase230 | 60 | 90~1600 | 68.0 | 490 | 31.9 | 230 | 55.5 | 400 | 1.1 | 218 |

ZP : These motors are impedance protected.

TP : These motors contain a built-in thermal protector. If a motor overheats for any reason, the thermal protector is opened and the motor stops. When the motor temperature drops, the thermal protector closes and the motor restarts. Be sure to turn the motor off before inspecting.

● The speed range is under no load conditions.

● The "U" and "E" at the end of the model number indicate that the unit includes a capacitor. These two letters are not listed on the motor nameplate.

■ General Specifications of Motors

After the rated motor operation under normal ambient temperature and humidity.

| Item | Specifications |
|-------------------------------|--|
| Insulation Resistance | 100MΩ or more when 500V DC is applied between the windings and the frame. |
| Dielectric Strength | Sufficient to withstand 1.5kV at 50Hz and 60Hz applied between the windings and the frame for 1 minute. |
| Temperature Rise | Induction Motor: 144°F (80°C) or less measured by the resistance change method under no load operation of motor with connecting a gearhead or equivalent heat radiation plate.* Reversible Motor: 144°F (80°C) or less measured by the resistance change method under no load operation for 30 minutes of motor with connecting a gearhead or equivalent heat radiation plate.* |
| Insulation Class | Class B [266°F (130°C)] |
| Overheating Protection Device | SC206 type is impedance protected. The other types contain a built-in thermal protector (automatic return type). Open : 266°F±9°F (130°C±5°C) Close: 179.6°F±27°F (82°C±15°C) |
| Ambient Temperature Range | 14°F~104°F (10°C~+40°C) |
| Ambient Humidity | 85% maximum (noncondensing) |
| Degree of protection | SC206, SC315, SC425, SC540 type IP20 SC560 type IP40 |

*See page (A-37) for heat radiation plate sizes.

■ General Specifications of Speed Control Pack

| Item | Specifications |
|---------------------------|---|
| Insulation Resistance | 100MΩ or more when 500V DC is applied between all the pins and the frame. |
| Dielectric Strength | Sufficient to withstand 2.3kV at 60Hz (Single-Phase 220, 230V : 3.0kV at 50Hz) applied between all the pins and the frame for 1 minute. |
| Ambient Temperature Range | 32°F~104°F (0°C~+40°C) |
| Ambient Humidity | 85% maximum (noncondensing) |
| Degree of protection | Speed Control Pack: IP20 (after connecting to surface connection socket) Surface connection socket: IP10 |

■ Gearmotor — Torque Table

● Induction Motors

Unit = Upper values: lb-in/Lower values: N-m

| Model | Gear Ratio | 3 | 3.6 | 5 | 6 | 7.5 | 9 | 12.5 | 15 | 18 | 25 | 30 | 36 | 50 | 60 | 75 | 90 | 100 | 120 | 150 | 180 |
|--------------------------------------|----------------|---------------|---------------|-------------|-------------|-------------|-------------|-------------|-------------|-------------|-------------|-------------|-------------|-------------|-----------|-----------|-----------|-----------|-----------|-----------|-----------|
| SC206-401WU /2GN□KA | 1200r/min | 1 0.12 | 1.3 0.15 | 1.7 0.2 | 2.1 0.24 | 2.6 0.3 | 3.1 0.36 | 4.4 0.51 | 5.2 0.61 | 6.3 0.73 | 7.9 0.91 | 9.4 1.1 | 11 1.3 | 14 1.7 | 17 2 | 21 2.5 | 26 3 | 26 3 | 26 3 | 26 3 | 26 3 |
| | 90r/min | 0.64 0.073 | 0.77 0.087 | 1.1 0.12 | 1.3 0.15 | 1.6 0.18 | 1.9 0.22 | 2.7 0.3 | 3.2 0.36 | 3.8 0.44 | 4.8 0.55 | 5.7 0.66 | 6.9 0.79 | 8.7 0.99 | 10 1.2 | 13 1.5 | 16 1.8 | 17 2 | 21 2.4 | 26 3 | 26 3 |
| SC206-402WE /2GN□KA | 1200r/min | 1 0.12 | 1.3 0.15 | 1.7 0.2 | 2.1 0.24 | 2.6 0.3 | 3.1 0.36 | 4.4 0.51 | 5.2 0.61 | 6.3 0.73 | 7.9 0.91 | 9.4 1.1 | 11 1.3 | 14 1.7 | 17 2 | 21 2.5 | 26 3 | 26 3 | 26 3 | 26 3 | 26 3 |
| | 90r/min | 0.64 0.073 | 0.77 0.087 | 1.1 0.12 | 1.3 0.15 | 1.6 0.18 | 1.9 0.22 | 2.7 0.3 | 3.2 0.36 | 3.8 0.44 | 4.8 0.55 | 5.7 0.66 | 6.9 0.79 | 8.7 0.99 | 10 1.2 | 13 1.5 | 16 1.8 | 17 2 | 21 2.4 | 26 3 | 26 3 |
| SC315-401WU /3GN□KA | 1200r/min | 2.6 0.3 | 3.2 0.36 | 4.4 0.51 | 5.3 0.61 | 6.6 0.76 | 7.9 0.91 | 11 1.3 | 13 1.5 | 16 1.8 | 20 2.3 | 24 2.7 | 29 3.3 | 36 4.1 | 43 5 | 43 5 | 43 5 | 43 5 | 43 5 | 43 5 | 43 5 |
| | 90r/min | 0.71 0.083 | 0.86 0.099 | 1.2 0.14 | 1.4 0.17 | 1.8 0.21 | 2.1 0.25 | 3 0.34 | 3.6 0.41 | 4.3 0.5 | 5.4 0.62 | 6.4 0.74 | 7.7 0.89 | 9.7 1.1 | 12 1.3 | 15 1.7 | 17 2 | 19 2.2 | 23 2.7 | 29 3.4 | 35 4 |
| SC315-402WE /3GN□KA | 1200r/min | 2.6 0.3 | 3.2 0.36 | 4.4 0.51 | 5.3 0.61 | 6.6 0.76 | 7.9 0.91 | 11 1.3 | 13 1.5 | 16 1.8 | 20 2.3 | 24 2.7 | 29 3.3 | 36 4.1 | 43 5 | 43 5 | 43 5 | 43 5 | 43 5 | 43 5 | 43 5 |
| | 90r/min | 0.71 0.083 | 0.86 0.099 | 1.2 0.14 | 1.4 0.17 | 1.8 0.21 | 2.1 0.25 | 3 0.34 | 3.6 0.41 | 4.3 0.5 | 5.4 0.62 | 6.4 0.74 | 7.7 0.89 | 9.7 1.1 | 12 1.3 | 15 1.7 | 17 2 | 19 2.2 | 23 2.7 | 29 3.4 | 35 4 |
| SC425-401WU /4GN□KA | 1200r/min | 3.4 0.39 | 4 0.47 | 5.6 0.65 | 6.7 0.78 | 8.4 0.97 | 10 1.2 | 14 1.6 | 17 1.9 | 20 2.3 | 25 2.9 | 30 3.5 | 36 4.2 | 46 5.3 | 55 6.3 | 69 7.9 | 69 8 | 69 8 | 69 8 | 69 8 | 69 8 |
| | 90r/min | 0.91 0.1 | 1.1 0.13 | 1.5 0.17 | 1.8 0.21 | 2.3 0.26 | 2.7 0.31 | 3.8 0.44 | 4.6 0.52 | 5.5 0.63 | 6.8 0.78 | 8.2 0.94 | 9.9 1.1 | 12 1.4 | 15 1.7 | 19 2.1 | 22 2.6 | 25 2.8 | 30 3.4 | 37 4.3 | 45 5.1 |
| SC425-402WE /4GN□KA | 1200r/min 230V | 4.3 | 5.2 | 7.2 | 8.7 | 11 | 13 | 18 | 22 | 26 | 33 | 39 | 47 | 59 | 69 | 69 | 69 | 69 | 69 | 69 | 69 |
| | 50Hz | 0.5 | 0.6 | 0.83 | 1 | 1.2 | 1.5 | 2.1 | 2.5 | 3 | 3.7 | 4.5 | 5.4 | 6.8 | 8 | 8 | 8 | 8 | 8 | 8 | 8 |
| | 230V | 3.4 | 4 | 5.6 | 6.7 | 8.4 | 10 | 14 | 17 | 20 | 25 | 30 | 36 | 46 | 55 | 69 | 69 | 69 | 69 | 69 | 69 |
| | 60Hz | 0.39 | 0.47 | 0.65 | 0.78 | 0.97 | 1.2 | 1.6 | 1.9 | 2.3 | 2.9 | 3.5 | 4.2 | 5.3 | 6.3 | 7.9 | 8 | 8 | 8 | 8 | 8 |
| SC540-401WU /5GN□KA | 1200r/min | 6.7 0.78 | 8.1 0.93 | 11 1.3 | 13 1.6 | 17 1.9 | 20 2.3 | 28 3.2 | 34 3.9 | 40 4.7 | 51 5.8 | 61 7 | 73 8.4 | 87 10 | 87 10 | 87 10 | 87 10 | 87 10 | 87 10 | 87 10 | 87 10 |
| | 90r/min | 1.2 0.13 | 1.4 0.16 | 1.9 0.22 | 2.3 0.27 | 2.9 0.33 | 3.5 0.4 | 4.8 0.56 | 5.8 0.67 | 6.9 0.8 | 8.7 1 | 10 1.2 | 12 1.4 | 16 1.8 | 19 2.2 | 24 2.7 | 28 3.3 | 31 3.6 | 38 4.4 | 47 5.4 | 56 6.5 |

Unit = Upper values: lb-in/Lower values:N·m

| Model | Gear Ratio | 3 | 3.6 | 5 | 6 | 7.5 | 9 | 12.5 | 15 | 18 | 25 | 30 | 36 | 50 | 60 | 75 | 90 | 100 | 120 | 150 | 180 |
|--------------------------------------|----------------|------|------|------|------|------|------|------|------|------|-----|-----|-----|-----|-----|-----|-----|-----|-----|-----|-----|
| SC540-402WE /5GN□KA | 1200r/min 230V | 6.7 | 8.1 | 11 | 13 | 17 | 20 | 28 | 34 | 40 | 51 | 61 | 73 | 87 | 87 | 87 | 87 | 87 | 87 | 87 | 87 |
| | 50Hz | 0.78 | 0.93 | 1.3 | 1.6 | 1.9 | 2.3 | 3.2 | 3.9 | 4.7 | 5.8 | 7 | 8.4 | 10 | 10 | 10 | 10 | 10 | 10 | 10 | 10 |
| | 230V | 5.1 | 6.1 | 8.4 | 10 | 13 | 15 | 21 | 25 | 30 | 38 | 46 | 55 | 69 | 82 | 87 | 87 | 87 | 87 | 87 | 87 |
| | 60Hz | 0.58 | 0.7 | 0.97 | 1.2 | 1.5 | 1.7 | 2.4 | 2.9 | 3.5 | 4.4 | 5.3 | 6.3 | 7.9 | 9.5 | 10 | 10 | 10 | 10 | 10 | 10 |
| | 90r/min | 1.4 | 1.6 | 2.3 | 2.7 | 3.4 | 4.1 | 5.7 | 6.8 | 8.2 | 10 | 12 | 15 | 19 | 22 | 28 | 33 | 37 | 45 | 56 | 67 |
| | | 0.16 | 0.19 | 0.26 | 0.32 | 0.39 | 0.47 | 0.66 | 0.79 | 0.95 | 1.2 | 1.4 | 1.7 | 2.1 | 2.6 | 3.2 | 3.9 | 4.3 | 5.1 | 6.4 | 7.7 |
| SC560-501WU /5GU□KA | 1200r/min | 8.2 | 9.9 | 14 | 16 | 21 | 25 | 31 | 37 | 45 | 56 | 67 | 80 | 112 | 134 | 150 | 174 | 174 | 174 | 174 | 174 |
| | | 0.95 | 1.1 | 1.6 | 1.9 | 2.4 | 2.8 | 3.6 | 4.3 | 5.1 | 6.4 | 7.7 | 9.3 | 13 | 15 | 17 | 20 | 20 | 20 | 20 | 20 |
| | 90r/min | 2 | 2.4 | 3.3 | 4 | 5 | 6 | 7.5 | 9 | 11 | 14 | 16 | 20 | 27 | 33 | 37 | 44 | 49 | 58 | 73 | 88 |
| | | 0.23 | 0.28 | 0.38 | 0.46 | 0.58 | 0.69 | 0.87 | 1 | 1.2 | 1.6 | 1.9 | 2.3 | 3.1 | 3.8 | 4.2 | 5 | 5.6 | 6.7 | 8.4 | 10 |
| SC560-502WE /5GU□KA | 1200r/min | 10 | 12 | 17 | 21 | 26 | 31 | 39 | 47 | 56 | 70 | 84 | 101 | 140 | 168 | 174 | 174 | 174 | 174 | 174 | 174 |
| | | 1.2 | 1.4 | 2 | 2.4 | 3 | 3.6 | 4.5 | 5.4 | 6.4 | 8.1 | 9.7 | 12 | 16 | 19 | 20 | 20 | 20 | 20 | 20 | 20 |
| | 90r/min | 4 | 4.8 | 6.7 | 8 | 10 | 12 | 15 | 18 | 22 | 27 | 33 | 39 | 54 | 65 | 73 | 88 | 97 | 117 | 146 | 174 |
| | | 0.46 | 0.55 | 0.77 | 0.92 | 1.2 | 1.4 | 1.7 | 2.1 | 2.5 | 3.1 | 3.8 | 4.5 | 6.3 | 7.5 | 8.4 | 10 | 11 | 13 | 17 | 20 |

● Reversible Motors

Unit = Upper values: lb-in/Lower values: N·m

| Model | Gear Ratio | 3 | 3.6 | 5 | 6 | 7.5 | 9 | 12.5 | 15 | 18 | 25 | 30 | 36 | 50 | 60 | 75 | 90 | 100 | 120 | 150 | 180 |
|--------------------------------------|--------------|-------|------|------|------|------|------|------|------|------|------|-----|-----|-----|-----|-----|-----|-----|-----|-----|-----|
| SC206-411WU /2GN□KA | 1200r/min | 1 | 1.3 | 1.7 | 2.1 | 2.6 | 3.1 | 4.4 | 5.2 | 6.3 | 7.9 | 9.4 | 11 | 14 | 17 | 21 | 26 | 26 | 26 | 26 | 26 |
| | | 0.12 | 0.15 | 0.2 | 0.24 | 0.3 | 0.36 | 0.51 | 0.61 | 0.73 | 0.91 | 1.1 | 1.3 | 1.7 | 2 | 2.5 | 3 | 3 | 3 | 3 | 3 |
| | 90r/min | 0.64 | 1.3 | 1.7 | 2.1 | 2.6 | 3.1 | 4.4 | 5.2 | 6.3 | 7.9 | 9.4 | 11 | 14 | 17 | 21 | 26 | 26 | 26 | 26 | 26 |
| | | 0.073 | 0.15 | 0.2 | 0.24 | 0.3 | 0.36 | 0.51 | 0.61 | 0.73 | 0.91 | 1.1 | 1.3 | 1.7 | 2 | 2.5 | 3 | 3 | 3 | 3 | 3 |
| SC206-412WE /2GN□KA | 1200r/min | 1 | 1.3 | 1.7 | 2.1 | 2.6 | 3.1 | 4.4 | 5.2 | 6.3 | 7.9 | 9.4 | 11 | 14 | 17 | 21 | 26 | 26 | 26 | 26 | 26 |
| | | 0.12 | 0.15 | 0.2 | 0.24 | 0.3 | 0.36 | 0.51 | 0.61 | 0.73 | 0.91 | 1.1 | 1.3 | 1.7 | 2 | 2.5 | 3 | 3 | 3 | 3 | 3 |
| | 90r/min | 0.64 | 1.3 | 1.7 | 2.1 | 2.6 | 3.1 | 4.4 | 5.2 | 6.3 | 7.9 | 9.4 | 11 | 14 | 17 | 21 | 26 | 26 | 26 | 26 | 26 |
| | | 0.073 | 0.15 | 0.2 | 0.24 | 0.3 | 0.36 | 0.51 | 0.61 | 0.73 | 0.91 | 1.1 | 1.3 | 1.7 | 2 | 2.5 | 3 | 3 | 3 | 3 | 3 |
| SC315-411WU /3GN□KA | 1200r/min | 2.6 | 3.2 | 4.4 | 5.3 | 6.6 | 7.9 | 11 | 13 | 16 | 20 | 24 | 29 | 36 | 43 | 43 | 43 | 43 | 43 | 43 | 43 |
| | | 0.3 | 0.36 | 0.51 | 0.61 | 0.76 | 0.91 | 1.3 | 1.5 | 1.8 | 2.3 | 2.7 | 3.3 | 4.1 | 5 | 5 | 5 | 5 | 5 | 5 | 5 |
| | 90r/min | 1.5 | 1.8 | 2.5 | 2.9 | 3.7 | 4.4 | 6.1 | 7.4 | 8.8 | 11 | 13 | 16 | 20 | 24 | 30 | 36 | 40 | 43 | 43 | 43 |
| | | 0.17 | 0.2 | 0.28 | 0.34 | 0.43 | 0.51 | 0.71 | 0.85 | 1 | 1.3 | 1.5 | 1.8 | 2.3 | 2.8 | 3.5 | 4.2 | 4.6 | 5 | 5 | 5 |
| SC315-412WE /3GN□KA | 1200r/min | 2.6 | 3.2 | 4.4 | 5.3 | 6.6 | 7.9 | 11 | 13 | 16 | 20 | 24 | 29 | 36 | 43 | 43 | 43 | 43 | 43 | 43 | 43 |
| | | 0.3 | 0.36 | 0.51 | 0.61 | 0.76 | 0.91 | 1.3 | 1.5 | 1.8 | 2.3 | 2.7 | 3.3 | 4.1 | 5 | 5 | 5 | 5 | 5 | 5 | 5 |
| | 90r/min | 1.5 | 1.8 | 2.5 | 2.9 | 3.7 | 4.4 | 6.1 | 7.4 | 8.8 | 11 | 13 | 16 | 20 | 24 | 30 | 36 | 40 | 43 | 43 | 43 |
| | | 0.17 | 0.2 | 0.28 | 0.34 | 0.43 | 0.51 | 0.71 | 0.85 | 1 | 1.3 | 1.5 | 1.8 | 2.3 | 2.8 | 3.5 | 4.2 | 4.6 | 5 | 5 | 5 |
| SC425-411WU /4GN□KA | 1200r/min | 4.3 | 5.2 | 7.2 | 8.7 | 11 | 13 | 18 | 22 | 26 | 33 | 39 | 47 | 59 | 69 | 69 | 69 | 69 | 69 | 69 | 69 |
| | | 0.5 | 0.6 | 0.83 | 1 | 1.2 | 1.5 | 2.1 | 2.5 | 3 | 3.7 | 4.5 | 5.4 | 6.8 | 8 | 8 | 8 | 8 | 8 | 8 | 8 |
| | 90r/min | 2 | 2.4 | 3.3 | 4 | 5 | 6 | 8.4 | 10 | 12 | 15 | 18 | 22 | 27 | 33 | 41 | 49 | 54 | 65 | 69 | 69 |
| | | 0.23 | 0.28 | 0.38 | 0.46 | 0.58 | 0.69 | 0.96 | 1.2 | 1.4 | 1.7 | 2.1 | 2.5 | 3.1 | 3.8 | 4.7 | 5.6 | 6.3 | 7.5 | 8 | 8 |
| SC425-412WE /4GN□KA | 1200r/min | 4.3 | 5.2 | 7.2 | 8.7 | 11 | 13 | 18 | 22 | 26 | 33 | 39 | 47 | 59 | 69 | 69 | 69 | 69 | 69 | 69 | 69 |
| | | 0.5 | 0.6 | 0.83 | 1 | 1.2 | 1.5 | 2.1 | 2.5 | 3 | 3.7 | 4.5 | 5.4 | 6.8 | 8 | 8 | 8 | 8 | 8 | 8 | 8 |
| | 90r/min | 2 | 2.4 | 3.3 | 4 | 5 | 6 | 8.4 | 10 | 12 | 15 | 18 | 22 | 27 | 33 | 41 | 49 | 54 | 65 | 69 | 69 |
| | | 0.23 | 0.28 | 0.38 | 0.46 | 0.58 | 0.69 | 0.96 | 1.2 | 1.4 | 1.7 | 2.1 | 2.5 | 3.1 | 3.8 | 4.7 | 5.6 | 6.3 | 7.5 | 8 | 8 |
| SC540-411WU /5GN□KA | 1200r/min | 6.7 | 8.1 | 11 | 13 | 17 | 20 | 28 | 34 | 40 | 51 | 61 | 73 | 87 | 87 | 87 | 87 | 87 | 87 | 87 | 87 |
| | | 0.78 | 0.93 | 1.3 | 1.6 | 1.9 | 2.3 | 3.2 | 3.9 | 4.7 | 5.8 | 7 | 8.4 | 10 | 10 | 10 | 10 | 10 | 10 | 10 | 10 |
| | 90r/min | 2.7 | 3.3 | 4.6 | 5.5 | 6.9 | 8.2 | 11 | 14 | 16 | 21 | 25 | 30 | 37 | 45 | 56 | 67 | 75 | 87 | 87 | 87 |
| | | 0.32 | 0.38 | 0.53 | 0.63 | 0.79 | 0.95 | 1.3 | 1.6 | 1.9 | 2.4 | 2.8 | 3.4 | 4.3 | 5.1 | 6.4 | 7.7 | 8.6 | 10 | 10 | 10 |
| SC540-412WE /5GN□KA | 1200r/min | 6.7 | 8.1 | 11 | 13 | 17 | 20 | 28 | 34 | 40 | 51 | 61 | 73 | 87 | 87 | 87 | 87 | 87 | 87 | 87 | 87 |
| | | 0.78 | 0.93 | 1.3 | 1.6 | 1.9 | 2.3 | 3.2 | 3.9 | 4.7 | 5.8 | 7 | 8.4 | 10 | 10 | 10 | 10 | 10 | 10 | 10 | 10 |
| | 90r/min 230V | 2.7 | 3.3 | 4.6 | 5.5 | 6.9 | 8.2 | 11 | 14 | 16 | 21 | 25 | 30 | 37 | 45 | 56 | 67 | 75 | 87 | 87 | 87 |
| | 50Hz | 0.32 | 0.38 | 0.53 | 0.63 | 0.79 | 0.95 | 1.3 | 1.6 | 1.9 | 2.4 | 2.8 | 3.4 | 4.3 | 5.1 | 6.4 | 7.7 | 8.6 | 10 | 10 | 10 |
| | 230V | 2.9 | 3.5 | 4.9 | 5.9 | 7.4 | 8.8 | 12 | 15 | 18 | 22 | 27 | 32 | 40 | 48 | 60 | 72 | 80 | 87 | 87 | 87 |
| | 60Hz | 0.34 | 0.41 | 0.57 | 0.68 | 0.85 | 1 | 1.4 | 1.7 | 2 | 2.6 | 3.1 | 3.7 | 4.6 | 5.5 | 6.9 | 8.3 | 9.2 | 10 | 10 | 10 |
| SC560-511WU /5GU□KA | 1200r/min | 8.4 | 10 | 14 | 17 | 21 | 25 | 32 | 38 | 46 | 57 | 69 | 82 | 114 | 137 | 153 | 174 | 174 | 174 | 174 | 174 |
| | | 0.97 | 1.2 | 1.6 | 1.9 | 2.4 | 2.9 | 3.7 | 4.4 | 5.3 | 6.6 | 7.9 | 9.5 | 13 | 16 | 18 | 20 | 20 | 20 | 20 | 20 |
| | 90r/min | 2.5 | 3 | 4.2 | 5.1 | 6.3 | 7.6 | 9.5 | 11 | 14 | 17 | 21 | 25 | 34 | 41 | 46 | 55 | 62 | 74 | 92 | 111 |
| | | 0.29 | 0.34 | 0.49 | 0.58 | 0.73 | 0.87 | 1.1 | 1.3 | 1.6 | 2 | 2.4 | 2.9 | 4 | 4.8 | 5.3 | 6.4 | 7.1 | 8.5 | 11 | 13 |
| SC560-512WE /5GU□KA | 1200r/min | 10 | 12 | 17 | 21 | 26 | 31 | 39 | 47 | 56 | 70 | 84 | 101 | 140 | 168 | 174 | 174 | 174 | 174 | 174 | 174 |
| | | 1.2 | 1.4 | 2 | 2.4 | 3 | 3.6 | 4.5 | 5.4 | 6.4 | 8.1 | 9.7 | 12 | 16 | 19 | 20 | 20 | 20 | 20 | 20 | 20 |
| | 90r/min 230V | 4.6 | 5.6 | 7.7 | 9.3 | 12 | 14 | 17 | 21 | 25 | 32 | 38 | 45 | 63 | 76 | 85 | 102 | 113 | 135 | 169 | 174 |
| | 50Hz | 0.53 | 0.64 | 0.89 | 1.1 | 1.3 | 1.6 | 2 | 2.4 | 2.9 | 3.6 | 4.4 | 5.2 | 7.3 | 8.7 | 9.7 | 12 | 13 | 16 | 19 | 20 |
| | 220V/230V | 4.8 | 5.8 | 8.1 | 9.7 | 12 | 15 | 18 | 22 | 26 | 33 | 39 | 47 | 66 | 79 | 88 | 106 | 118 | 141 | 174 | 174 |
| | 60Hz | 0.56 | 0.67 | 0.93 | 1.1 | 1.4 | 1.7 | 2.1 | 2.5 | 3 | 3.8 | 4.6 | 5.5 | 7.6 | 9.1 | 10 | 12 | 14 | 16 | 20 | 20 |

● Gearheads and decimal gearheads are sold separately.

● Enter the gear ratio in the box (□) within the model number. A colored background indicates gear shaft rotation in the same direction as the motor shaft; a white background indicates rotation in the opposite direction.

● Values for permissible torque are calculated by taking the permissible torque at high speed (1200r/min) and low speed (90r/min) and multiplying by the gear ratio and gearhead efficiency.

Torque-Speed Characteristics

Induction Motors

Single-Phase 110V/115V

SC206-401WU
SC206-001WU

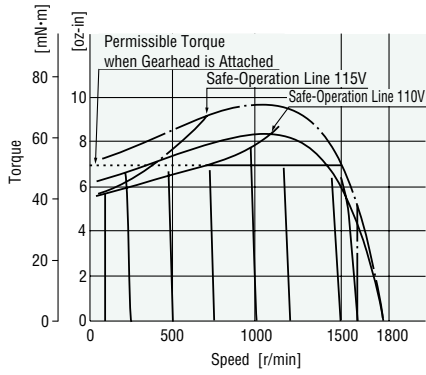

SC315-401WU
SC315-001WU

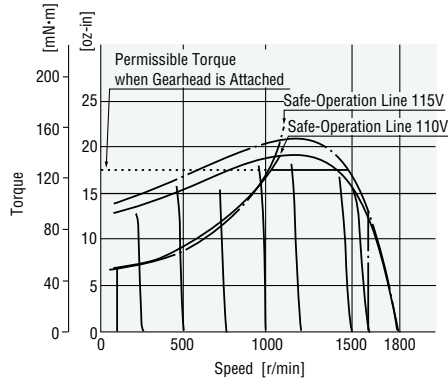

SC425-401WU
SC425-001WU

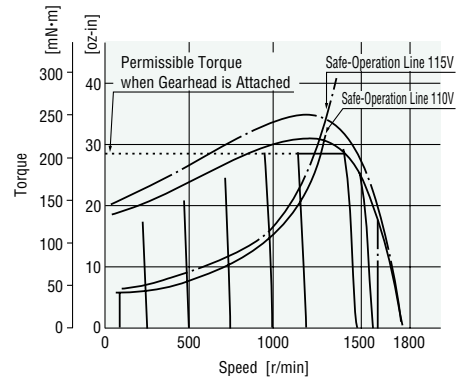

SC540-401WU
SC540-001WU

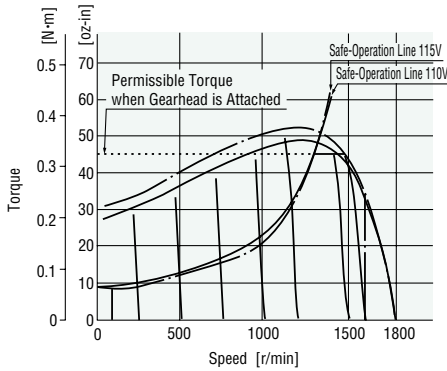

SC560-501WU
SC560-001WU

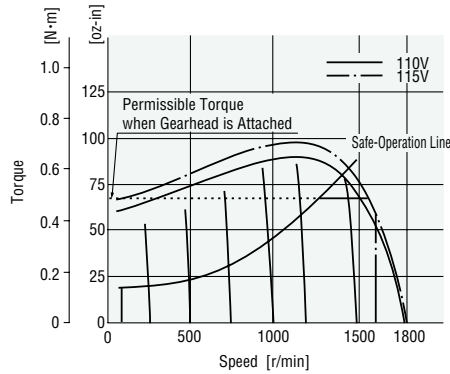

Single-Phase 220V/230V

SC206-402WE
SC206-002WE

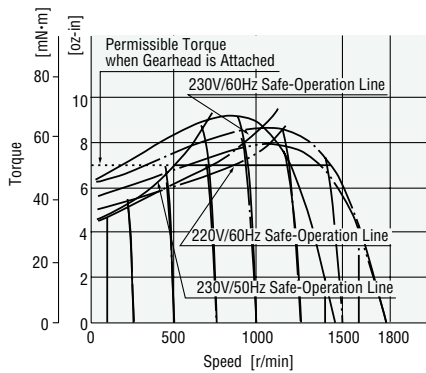

SC315-402WE
SC315-002WE

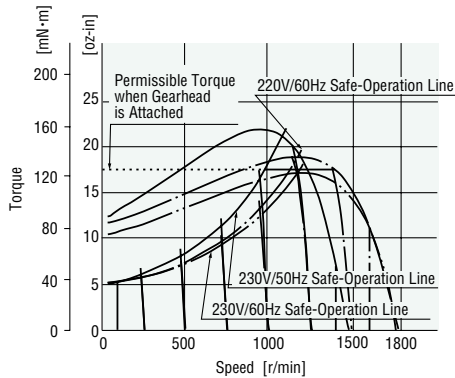

SC425-402WE
SC425-002WE

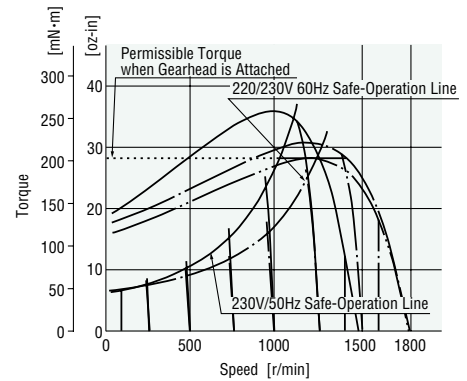

SC540-402WE
SC540-002WE

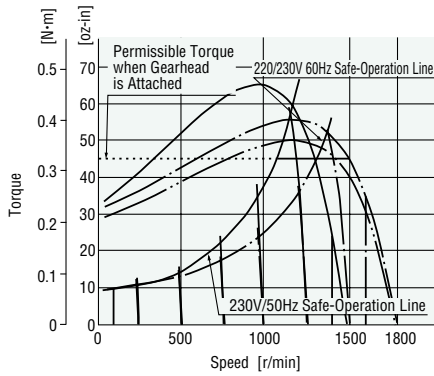

SC560-502WE
SC560-002WE

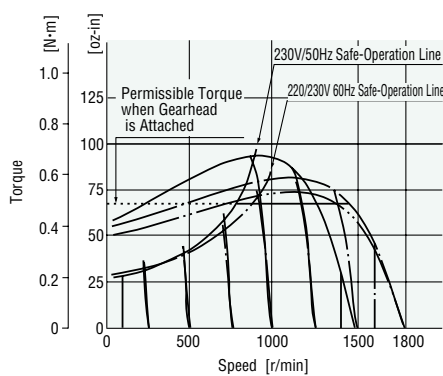

● **Reversible Motors**
Single-Phase 110V/115V
SC206-411WU
SC206-011WU

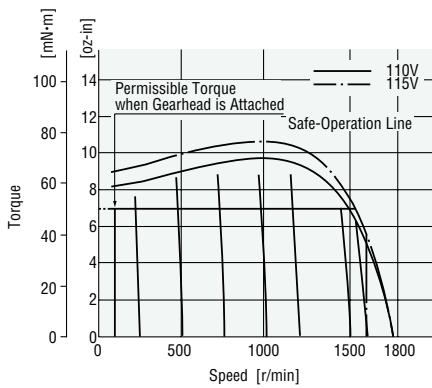

SC315-411WU
SC315-011WU

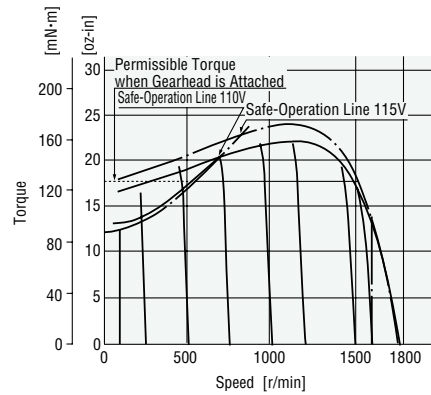

SC425-411WU
SC425-011WU

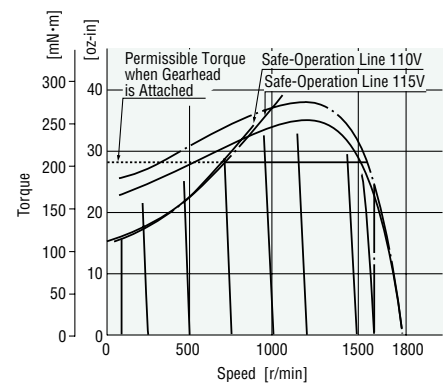

SC540-411WU
SC540-011WU

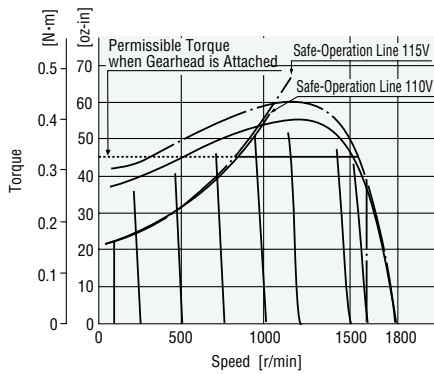

SC560-511WU
SC560-011WU

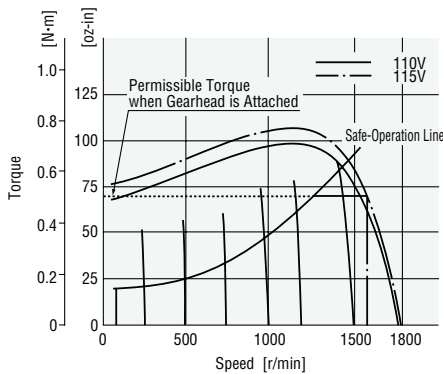

Single-Phase 220V/230V

SC206-412WE

SC206-012WE

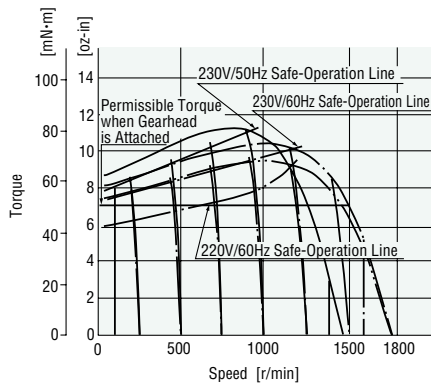

SC315-412WE

SC315-012WE

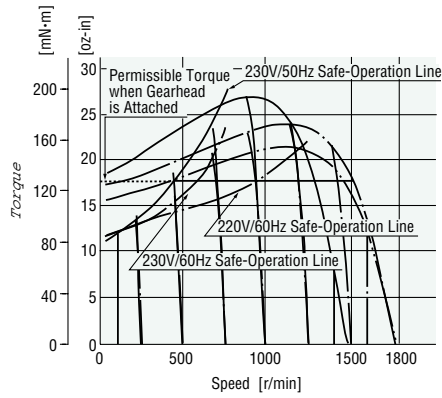

SC425-412WE

SC425-012WE

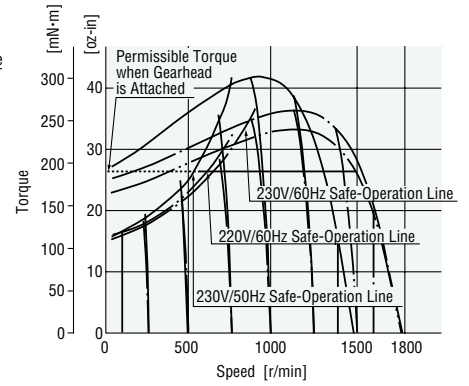

SC540-412WE

SC540-012WE

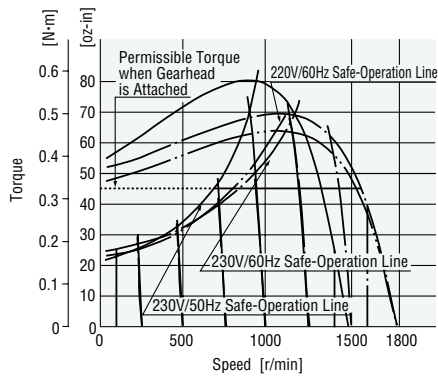

SC560-512WE

SC560-012WE

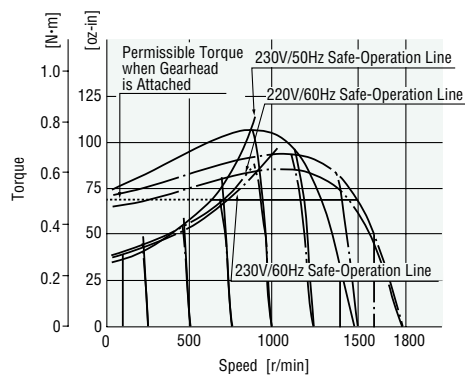

■ Wiring Diagrams

● Induction Motor

Uni-directional Operation, Speed Control

● 6W, 15W, 25W, 40W type

Speed

Control Pack

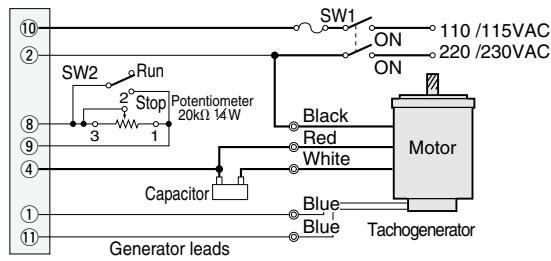

● Operation Chart

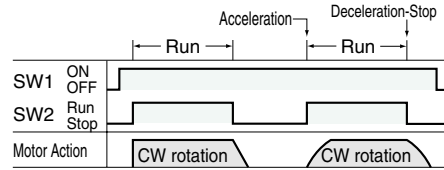

Run/Stop

Motor rotates at a speed set on the external speed potentiometer when switch SW2 is flipped to RUN (open). When SW2 is flipped to STOP (short circuit), the motor stops (natural stop).

Direction of Rotation

These wiring diagrams refer to clockwise (CW) rotation as viewed from the front shaft end of the motor. To rotate the motor in a counterclockwise (CCW) direction, reverse the red and white wires.

Run (Acceleration)/Stop (Deceleration)

To operate or stop the motor, use switch SW2. When SW2 is flipped to RUN (open), the motor accelerates to the speed set on the external speed potentiometer. When SW2 is flipped to STOP (short circuit), the motor decelerates to a stop.

| Switch No | Specifications |
|-----------|----------------------------------|
| SW1 | 125VAC, 5A Min or 250VAC, 5A Min |
| SW2 | DC20V 10mA |

Note: The direction of rotation should not be reversed when the power supply is first turned on.

● 60W type

Speed

Control Pack

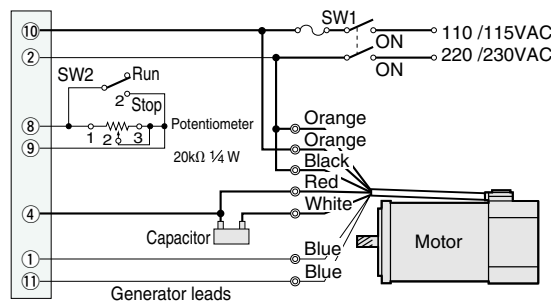

● Reversible Motors

Bi-directional Operation, Speed Control

● 6W, 15W, 25W, 40W type

Speed

Control Pack

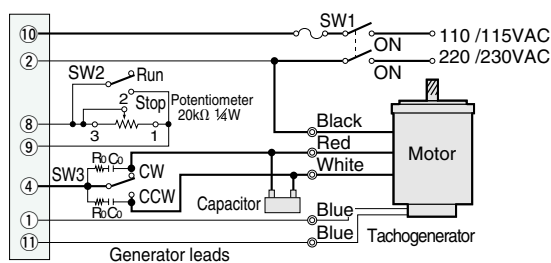

● Operation Chart

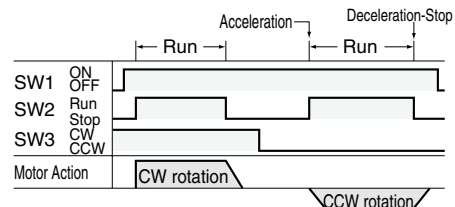

Run/Stop

Motor rotates at a speed set on the external speed potentiometer when switch SW2 is flipped to RUN (open). When SW2 is flipped to STOP (short circuit), the motor stops (natural stop).

Direction of Rotation

To rotate the motor in a clockwise (CW) direction, flip switch SW3 to CW. To rotate it in a counterclockwise (CCW) direction, flip SW3 to CCW. The direction of rotation is as viewed from the shaft end of the motor.

Run (Acceleration)/Stop (Deceleration)

To operate or stop the motor, use switch SW2. When SW2 is flipped to RUN (open), the motor accelerates to the speed set on the external speed potentiometer. When SW2 is flipped to STOP (short circuit), the motor decelerates to a stop.

Acceleration time and deceleration time are set with the built-in timing potentiometer located on the front surface.

| Switch No | Specifications | Note |
|------------------|--------------------------------|-------------------|
| SW1 | 125VAC 5A Min or 250VAC 5A Min | — |
| SW2 | DC20V 10mA | — |
| SW3 | 125VAC 5A Min or 250VAC 5A Min | — |
| Ro · Co | Ro=5~200 Ω | Accessory |
| Surge Suppressor | Co=0.1~0.2μ F 200WV (400WV) | EPCR1201-2 |

Note: The direction of rotation should not be reversed when the power supply is first turned on.

● 60W type

Speed

Control Pack

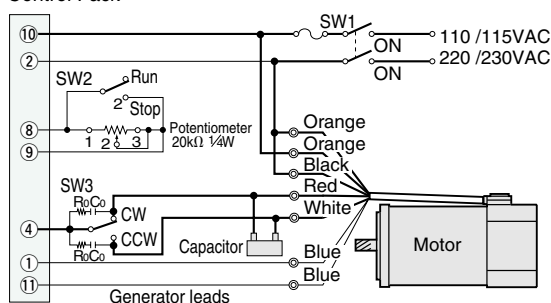

Speed Control

Setting Speed Using External Speed Potentiometer

The changes in speed are caused by resistance values. These changes are shown on the graph. In actual use, the circuit error and the error in the voltage produced by rate generator may cause an error in the set speed of $\pm 10\%$

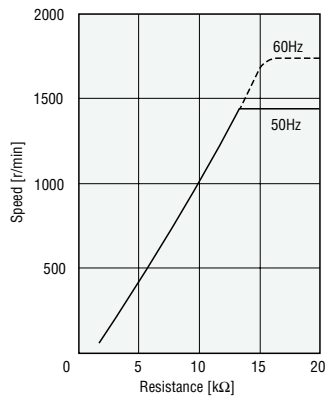

Speed Potentiometer Resistance-Value Speed Characteristics

Speed Control by External DC Control Voltage

The following figures show the connection for speed control using an external DC control voltage.

When using this method, make certain that the DC power supply is isolated from the AC input of the motor.

For SELV Circuit

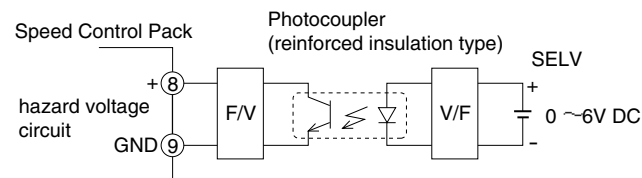

For Non-SELV Circuit

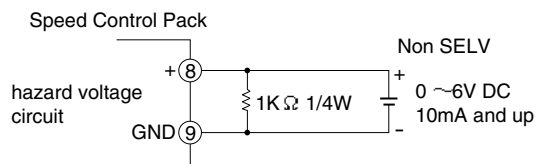

Note:

- Speed setting input terminals (8) and (9) are not insulated from dangerous voltages. You must use a reinforced isolation system between the speed control pack and a SELV circuit*.
- Check that the DC power supply comes from an AC power supply through a transformer and is insulated.
- *A SELV (Safety Extra Low Voltage) circuit (Max. DC60V or 42.4V peak) is isolated by reinforced insulation from hazardous voltage.

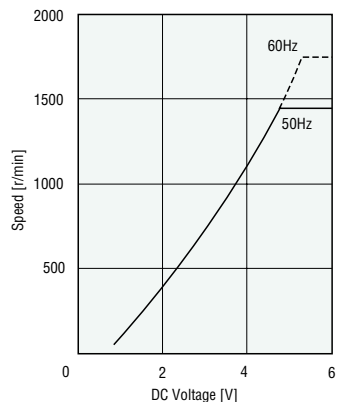

Speed Setting Voltage-Speed Characteristics

Installing the Speed Control Pack

Installing the Speed Control Pack

Use the flush mounting socket to install the control pack. The protection class of the flush mounting socket is IP10. When adjusting the acceleration/deceleration time with the power on, install an insulation cover to prevent touching the terminal connections as shown in the diagram below.

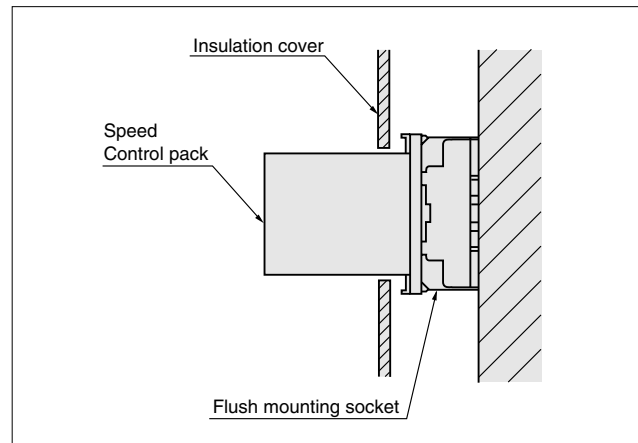

Acceleration / Deceleration Function

The **SC** Series has a special function allowing slow linear acceleration from start to operating speed and slow linear deceleration from the operating speed down to zero.

This makes it possible to prevent shock to the load and to accelerate/decelerate smoothly.

The desired values for acceleration and deceleration can be set independently using the built-in timing potentiometers on the top of the speed control pack.

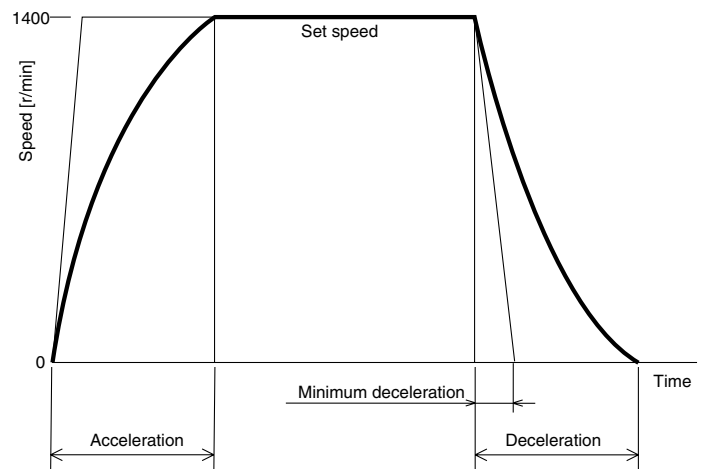

- Motor motion profile with acceleration/deceleration operation
- Motor motion profile without acceleration/deceleration operation

Turning the dial in a clockwise direction extends the acceleration/deceleration time. Acceleration and deceleration time can be adjusted within a range of 2 to 10 seconds. The dials are set to 0 before being shipped from the factory. Set the dial to 0 when not performing acceleration/deceleration operation.

Note: Use an insulated miniature screwdriver for adjusting the timing potentiometers.

■ List of Motor and Speed Control Pack Combination

● Induction Motors Single-Phase 110V/115V

| Unit Model | Motor Model | Control Pack Model |
|--------------------|-------------|--------------------|
| SC206-401WU | MSM206-401W | SSP-1 |
| SC206-001WU | MSM206-001W | |
| SC315-401WU | MSM315-401W | |
| SC315-001WU | MSM315-001W | |
| SC425-401WU | MSM425-401W | |
| SC425-001WU | MSM425-001W | |
| SC540-401WU | MSM540-401W | |
| SC540-001WU | MSM540-001W | |
| SC560-501WU | MSM560-501W | |
| SC560-001WU | MSM560-001W | |

● Induction Motors Single-Phase 220V/230V

| Unit Model | Motor Model | Control Pack Model |
|--------------------|-------------|--------------------|
| SC206-402WE | MSM206-402W | SSP-2 |
| SC206-002WE | MSM206-002W | |
| SC315-402WE | MSM315-402W | |
| SC315-002WE | MSM315-002W | |
| SC425-402WE | MSM425-402W | |
| SC425-002WE | MSM425-002W | |
| SC540-402WE | MSM540-402W | |
| SC540-002WE | MSM540-002W | |
| SC560-502WE | MSM560-502W | |
| SC560-002WE | MSM560-002W | |

● Reversible Motors Single-Phase 110V/115V

| Unit Model | Motor Model | Control Pack Model |
|--------------------|-------------|--------------------|
| SC206-411WU | MSM206-411W | SSP-1 |
| SC206-011WU | MSM206-011W | |
| SC315-411WU | MSM315-411W | |
| SC315-011WU | MSM315-011W | |
| SC425-411WU | MSM425-411W | |
| SC425-011WU | MSM425-011W | |
| SC540-411WU | MSM540-411W | |
| SC540-011WU | MSM540-011W | |
| SC560-511WU | MSM560-511W | |
| SC560-011WU | MSM560-011W | |

● Reversible Motors Single-Phase 220V/230V

| Unit Model | Motor Model | Control Pack Model |
|--------------------|-------------|--------------------|
| SC206-412WE | MSM206-412W | SSP-2 |
| SC206-012WE | MSM206-012W | |
| SC315-412WE | MSM315-412W | |
| SC315-012WE | MSM315-012W | |
| SC425-412WE | MSM425-412W | |
| SC425-012WE | MSM425-012W | |
| SC540-412WE | MSM540-412W | |
| SC540-012WE | MSM540-012W | |
| SC560-512WE | MSM560-512W | |
| SC560-012WE | MSM560-012W | |

■ Dimensions Scale 1/4, Unit= inch (mm)

SC206-4□1WU (Pinion shaft)

SC206-4□2WE

Motor

MSM206-4 □1W

MSM206-4 □2W

Weight (Mass) : 1.8 lb. (0.8kg)

Gearhead

2GN□KA (sold separately)

Weight (Mass) : 0.88 lb. (0.4kg)

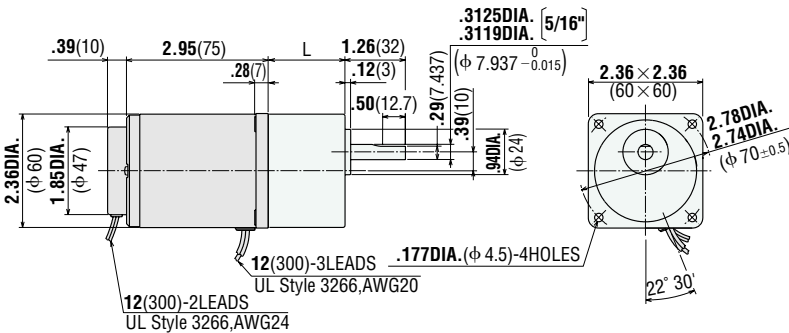

L=1.18(30) **2GN3KA~18KA**

L=1.57(40) **2GN25KA~180KA**

● Round shaft Type

SC206-0□1WU

SC206-0□2WE

Weight (Mass) : 1.8 lb. (0.8kg)

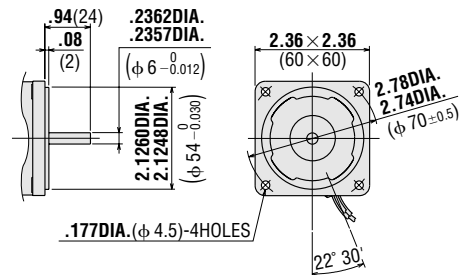

SC315-4 □ **1WU** (Pinion shaft)

SC315-4 □ **2WE**

Motor

MSM315-4 □ **1W**

MSM315-4 □ **2W**

Weight (Mass): 2.6 lb. (1.2kg)

Gearhead

3GN □ **KA**

Weight (Mass): 1.21 lb. (0.55kg)

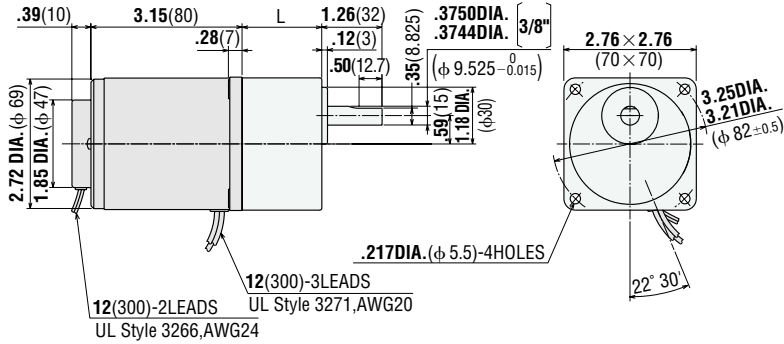

L=1.26(32) **3GN3KA ~ 18KA**

L=1.65(42) **3GN25KA ~ 180KA**

SC425-4 □ **1WU** (Pinion shaft)

SC425-4 □ **2WE**

Motor

MSM425-4 □ **1W**

MSM425-4 □ **2W**

Weight (Mass): 3.5 lb. (1.6kg)

Gearhead

4GN □ **KA**

Weight (Mass): 1.43 lb. (0.65kg)

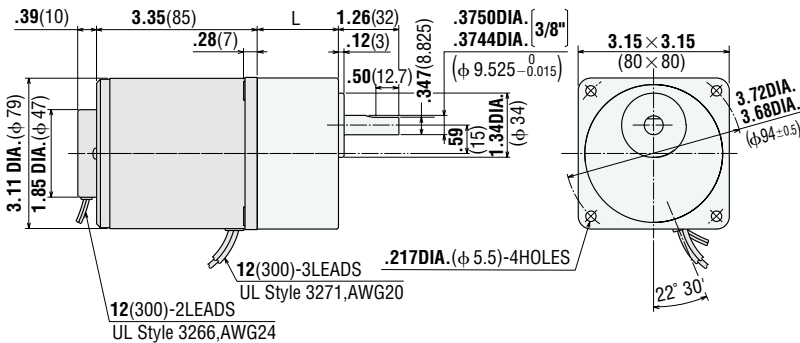

L=1.26(32) **4GN3KA ~ 18KA**

L=1.67(42.5) **4GN25KA ~ 180KA**

SC540-4 □ **1WU** (Pinion shaft)

SC540-4 □ **2WE**

Motor

MSM540-4 □ **1W**

MSM540-4 □ **2W**

Weight (Mass): 5.7 lb. (2.6kg)

Gearhead

5GN □ **KA**

Weight (Mass): 3.3 lb. (1.5kg)

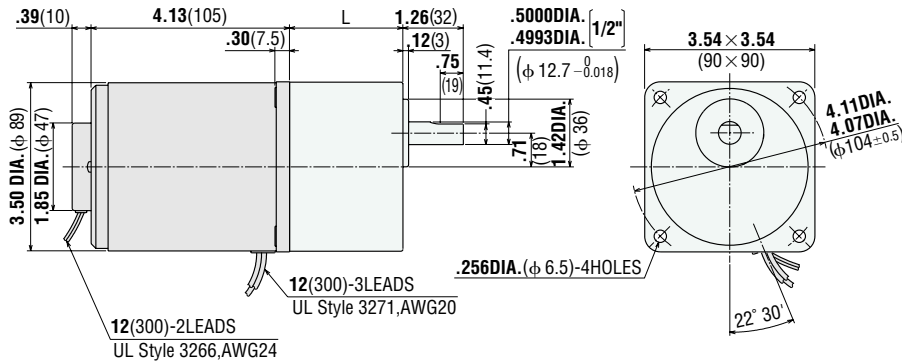

L=1.65(42) **5GN3KA ~ 18KA**

L=2.36(60) **5GN25KA ~ 180KA**

● Round shaft Type

SC315-0 □ **1WU**

SC315-0 □ **2WE**

Weight (Mass): 2.6 lb. (1.2kg)

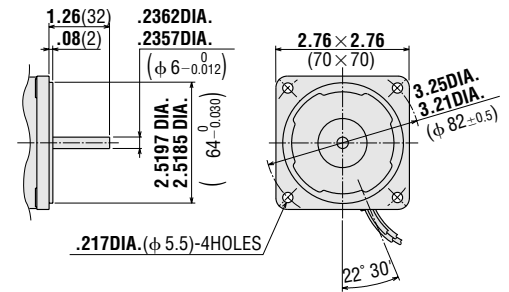

● Round shaft Type

SC425-0 □ **1WU**

SC425-0 □ **2WE**

Weight (Mass): 3.5 lb. (1.6kg)

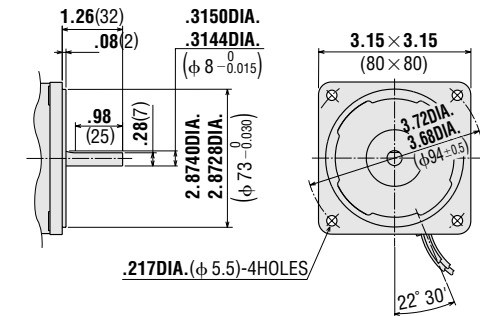

● Round Shaft Type

SC540-0 □ **1WU**

SC540-0 □ **2WE**

Weight (Mass): 5.7 lb. (2.6kg)

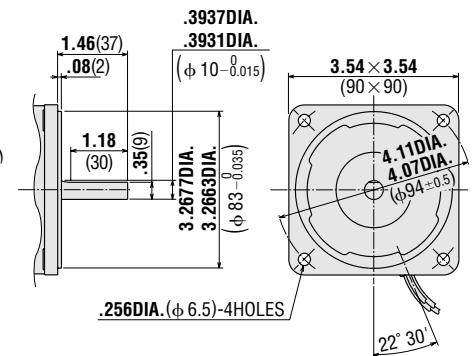

SC560-5□1WU (Pinion shaft)

SC560-5□2WE

Motor
MSM560-5□1W / **5GU□KA**
MSM560-5□2W / **5GU□KA**
Weight (Mass): 3.3 lb. (1.5kg)
Weight (Mass): 7.1 lb. (3.2kg)

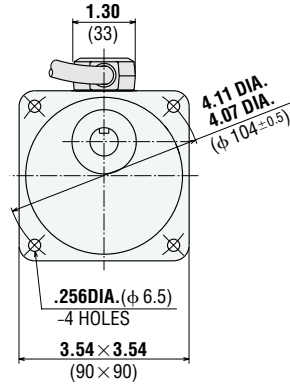
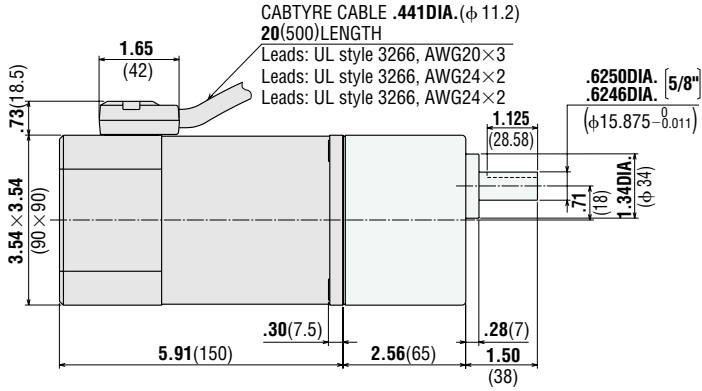

● **Round Shaft Type**

SC560-0□1WU

SC560-0□2WE

Weight (Mass): 7.1 lb. (3.2kg)

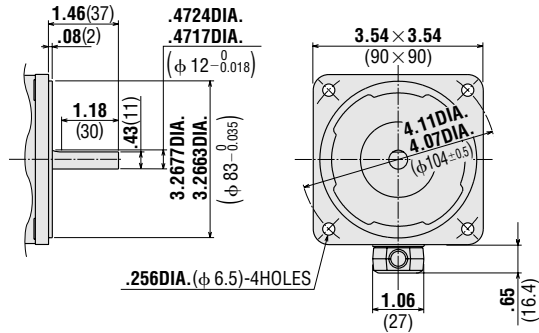

● **Key and Key Slot** (Scale 1/2)

The key is provided **5GU□KA** gearhead.

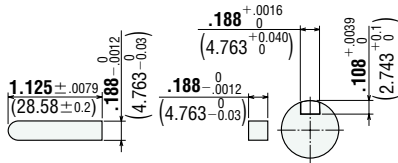

■ **Dimensions of Speed Control Pack** Scale 1/4, Unit = inch (mm)

Speed Control Pack SSP-1 Weight (Mass): 0.44 lb. (0.2kg)
SSP-2

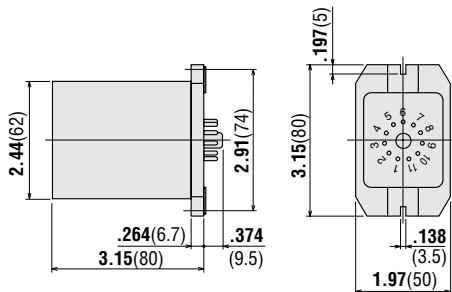

● **Flush Mounting Socket** (Provided with speed control pack)

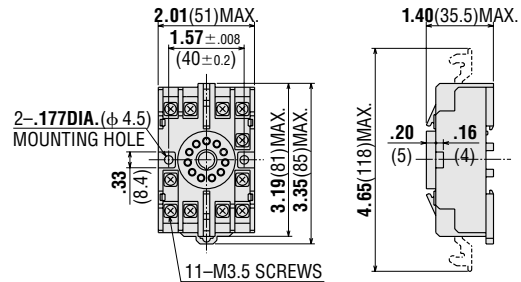

● **Potentiometer** (Provided with speed control pack)

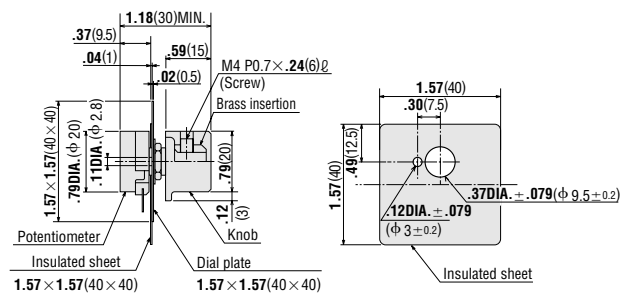

● **Capacitor** (included with the motor)

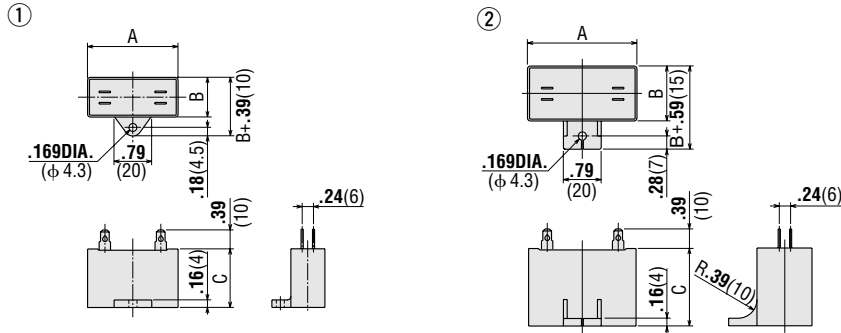

Dimensions

Unit = inch (mm)

| Unit Model | Capacitor Model | A | B | C | Weight (Mass) oz (g) | Dimension No. |
|---------------------------------------|-----------------|-----------|-------------|-------------|-------------------------|------------------|
| SC206-401WU SC206-001WU | CH25FAUL | 1.22 (31) | 0.67 (17) | 1.06 (27) | 0.71 (20) | ① |
| SC206-411WU SC206-011WU | CH35FAUL | 1.22 (31) | 0.67 (17) | 1.06 (27) | 0.88 (25) | |
| SC315-401WU SC315-001WU | CH45FAUL | 1.46 (37) | 0.71 (18) | 1.06 (27) | 1.06 (30) | |
| SC315-411WU SC315-011WU | CH60CFAUL | 1.50 (38) | 0.83 (21) | 1.22 (31) | 1.41 (40) | |
| SC425-401WU SC425-001WU | CH65CFAUL | 1.50 (38) | 0.83 (21) | 1.22 (31) | 1.23 (35) | |
| SC425-411WU SC425-011WU | CH80CFAUL | 1.89 (48) | 0.75 (19) | 1.14 (29) | 1.41 (40) | |
| SC540-401WU SC540-001WU | CH90CFAUL | 1.89 (48) | 0.83 (21) | 1.22 (31) | 1.41 (40) | |
| SC540-411WU SC540-011WU | CH120CFAUL | 2.28 (58) | 0.83 (21) | 1.22 (31) | 1.76 (50) | ② |
| SC560-501WU SC560-001WU | CH180CFAUL | 2.28 (58) | 0.93 (23.5) | 1.46 (37) | 2.47 (70) | |
| SC560-511WU SC560-011WU | CH200CFAUL | 2.28 (58) | 1.14 (29) | 1.61 (41) | 3.35 (95) | |
| SC206-402WE SC206-002WE | CH06BFAUL | 1.22 (31) | 0.57 (14.5) | 0.93 (23.5) | 0.53 (15) | ① |
| SC206-412WE SC206-012WE | CH08BFAUL | 1.22 (31) | 0.67 (17) | 1.06 (27) | 0.88 (25) | |
| SC315-402WE SC315-002WE | CH10BFAUL | 1.46 (37) | 0.71 (18) | 1.06 (27) | 1.06 (30) | |
| SC315-412WE SC315-012WE | CH15BFAUL | 1.50 (38) | 0.83 (21) | 1.22 (31) | 1.23 (35) | |
| SC425-402WE SC425-002WE | CH15BFAUL | 1.50 (38) | 0.83 (21) | 1.22 (31) | 1.23 (35) | |
| SC425-412WE SC425-012WE | CH20BFAUL | 1.89 (48) | 0.75 (19) | 1.14 (29) | 1.23 (35) | |
| SC540-402WE SC540-002WE | CH23BFAUL | 1.89 (48) | 0.83 (21) | 1.22 (31) | 1.41 (40) | |
| SC540-412WE SC540-012WE | CH35BFAUL | 2.28 (58) | 0.87 (22) | 1.38 (35) | 1.94 (55) | ② |
| SC560-502WE SC560-002WE | CH40BFAUL | 2.28 (58) | 0.93 (23.5) | 1.46 (37) | 2.47 (70) | |
| SC560-512WE SC560-012WE | CH50BFAUL | 2.28 (58) | 1.14 (29) | 1.61 (41) | 3.00 (85) | |

Capacitor cap is provided with the capacitor.

■ **Right-Angle Gearheads (sold separately)**

The right-angle gearhead provides an output shaft at a right angle to the motor's output shaft.

See page [A-216] for more information.

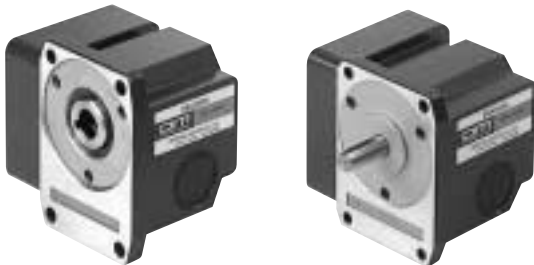

■ **Accessories (sold separately)**

● **Motor Mounting Brackets**

Optional die-cast aluminum mounting brackets are available. They can be used to install motors without gearheads.

See page [A-266] for more information.



● **Flexible Couplings**

Optional flexible couplings are available.

See page [A-260] for more information.



Speed Control Motors

US Series

The US series combines a speed control motor and a control unit. The capacitor and the potentiometer have been integrated into one compact control unit. The series is designed for applications where remote control of the motor speed and easy hook-up are required.



Gearhead shown in the photograph is sold separately.



■ Features

- Control units combine the control pack, potentiometer and the capacitor in one device. Capacitors for **US560** and **US590** types are externally fitted with leads and capacitor caps. Connection between motor and control unit is simplified by a special connector.
- Use of the optional extension cable allows for remote control of the motor from a distance of up to 15.6 feet.(4.75m).
- Variable speed range is 90r/min ~ 1400r/min (50Hz), 90r/min~ 1600r/min (60Hz).

■ Safety Standards and CE Marking

| Motor | | | |
|---|---|--|--------------------------|
| Standards | Certification Body | Standards File No. | CE Marking |
| UL1004 UL519 (US206 type) UL547 (US315, US425, US540, US560, US590 type) | UL | E64199 (US206 type) E64197 (US315, US425, US540, US560, US590 type) | Low Voltage Directive |
| CAN/CSA-C22.2 No.100 CAN/CSA-C22.2 No.77 | | | |
| EN60950 | VDE | 114919ÜG (US206 type) 6751ÜG (US315, US425, US540, US560, US590 type) | |
| EN60034-1 EN60034-5 IEC60034-11 | Conform to EN/IEC Standards (EN/IEC certifications are scheduled.) | | |
| Control Unit | | | |
| Standards | Certification Body | Standards File No. | CE Marking |
| UL508 CAN/CSA-C22.2 No.14 | UL | E91291 | Low Voltage Directive |
| EN60950 | | Conform to EN/VDE Standards (EN/IEC certifications are scheduled.) | |

• For installations for EN/IEC standards, see page D-2.

■ Product Number Code

US 5 60 -5 0 1 U

| | | | | | | | | | | |
|--|--|--|--|--|--|--|--|--|--|--|
| | | | | | | | | | | |
| | | | | | | | | | | Provided Capacitor U: 110V/115V E: 220V/230V |
| | | | | | | | | | | Voltage 1: Single-Phase 110V/115V, 4 Poles 2: Single-Phase 220V/230V, 4 Poles |
| | | | | | | | | | | Motor type O: Induction motor (Continuous rating) |
| | | | | | | | | | | Shaft type O: Round shaft 4: GN pinion shaft (for use with GN type gearhead) 5: GU pinion shaft (for use with GU type gearhead) |
| | | | | | | | | | | Output Power 06: 6W 40: 40W 15: 15W 60: 60W 25: 25W 90: 90W |
| | | | | | | | | | | Motor Frame Size 2: 2.36 inch sq.(60mm sq.) 3: 2.76 inch sq.(70mm sq.) 4: 3.15 inch sq.(80mm sq.) 5: 3.54 inch sq.(90mm sq.) |

US series

Note: The "U" and "E" at the end of the model number indicate that the unit includes a capacitor. These two letters are not listed on the motor nameplate.

■ Product Line

● Single-Phase 110V/115V

| Output Power | | Model | |
|--------------|----|-------------------|-------------------|
| HP | W | Pinion shaft | Round shaft |
| 1/124 | 6 | US206-401U | US206-001U |
| 1/50 | 15 | US315-401U | US315-001U |
| 1/30 | 25 | US425-401U | US425-001U |
| 1/18.5 | 40 | US540-401U | US540-001U |
| 1/12.5 | 60 | US560-501U | US560-001U |
| 1/8 | 90 | US590-501U | US590-001U |

● Single-Phase 220V/230V

| Output Power | | Model | |
|--------------|----|-------------------|-------------------|
| HP | W | Pinion shaft | Round shaft |
| 1/124 | 6 | US206-402E | US206-002E |
| 1/50 | 15 | US315-402E | US315-002E |
| 1/30 | 25 | US425-402E | US425-002E |
| 1/18.5 | 40 | US540-402E | US540-002E |
| 1/12.5 | 60 | US560-502E | US560-002E |
| 1/8 | 90 | US590-502E | US590-002E |

● Gearheads

| Motor Model | Gearhead Model |
|---------------------|------------------------------------|
| US206 | 2GN3KA ~ 2GN180KA |
| | 2GN10XK (Decimal Gearhead) |
| US315 | 3GN3KA ~ 3GN180KA |
| | 3GN10XK (Decimal Gearhead) |
| US425 | 4GN3KA ~ 4GN180KA |
| | 4GN10XK (Decimal Gearhead) |
| US540 | 5GN3KA ~ 5GN180KA |
| | 5GN10XK (Decimal Gearhead) |
| US560, US590 | 5GU3KA ~ 5GU180KA |
| | 5GU10XKB (Decimal Gearhead) |

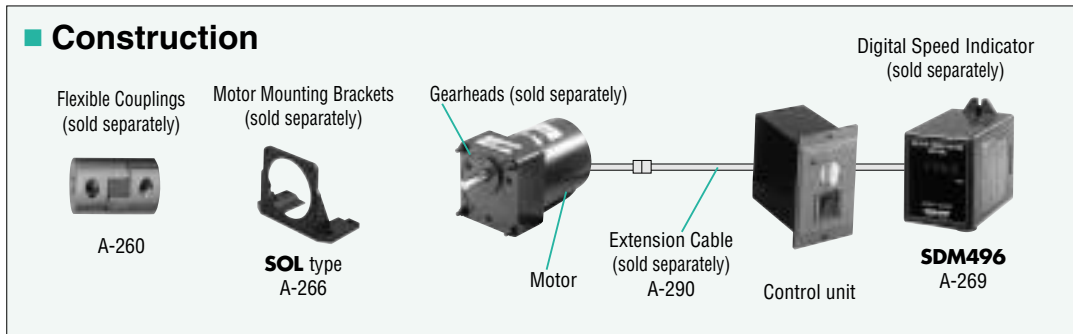

■ List of Motor/Control Unit Packages

Model numbers for motor/control unit packages are shown below.

● Single-Phase 110V/115V

| Output Power | Packages | Motor Model | Control Unit Model |
|--------------|----------|-------------------|--------------------|
| HP | W | Model | Model |
| 1/124 | 6 | US206-401U | USM206-401W |
| | | US206-001U | USM206-001W |
| 1/50 | 15 | US315-401U | USM315-401W |
| | | US315-001U | USM315-001W |
| 1/30 | 25 | US425-401U | USM425-401W |
| | | US425-001U | USM425-001W |
| 1/18.5 | 40 | US540-401U | USM540-401W |
| | | US540-001U | USM540-001W |
| 1/12.5 | 60 | US560-501U | USM560-501W |
| | | US560-001U | USM560-001W |
| 1/8 | 90 | US590-501U | USM590-501W |
| | | US590-001U | USM590-001W |

● Single-Phase 220V/230V

| Output Power | Packages | Motor Model | Control Unit Model |
|--------------|----------|-------------------|--------------------|
| HP | W | Model | Model |
| 1/124 | 6 | US206-402E | USM206-402W |
| | | US206-002E | USM206-002W |
| 1/50 | 15 | US315-402E | USM315-402W |
| | | US315-002E | USM315-002W |
| 1/30 | 25 | US425-402E | USM425-402W |
| | | US425-002E | USM425-002W |
| 1/18.5 | 40 | US540-402E | USM540-402W |
| | | US540-002E | USM540-002W |
| 1/12.5 | 60 | US560-502E | USM560-502W |
| | | US560-002E | USM560-002W |
| 1/8 | 90 | US590-502E | USM590-502W |
| | | US590-002E | USM590-002W |

Product Specifications

■ Specifications (Motor) — Continuous Rating

| Model | | Maximum Output Power HP W | Voltage V | Frequency Hz | Speed Range r/min | Permissible Torque | | | | Starting Torque | | Current A | Power Consumption W |
|---------------------|-------------------|------------------------------|--------------|-----------------|----------------------|--------------------|------|-----------|---------|-----------------|------|--------------|------------------------|
| Pinion shaft | Round shaft | | | | | oz-in | mN·m | 1200r/min | 90r/min | oz-in | mN·m | | |
| Ⓜ US206-401U | US206-001U | 1/124 6 | 110 | 60 | 90~1600 | 6.9 | 50 | 4.2 | 30 | 4.9 | 35 | 0.24 | 24 |
| | | | 115 | 60 | 90~1600 | 6.9 | 50 | 4.2 | 30 | 4.9 | 35 | 0.25 | 28 |
| Ⓜ US206-402E | US206-002E | 1/124 6 | 220 | 60 | 90~1600 | 6.9 | 50 | 4.0 | 29 | 3.7 | 27 | 0.13 | 27 |
| | | | 230 | 50 | 90~1400 | 6.9 | 50 | 4.0 | 29 | 4.0 | 29 | 0.13 | 28 |
| Ⓜ US206-402E | US206-002E | 1/124 6 | 230 | 60 | 90~1600 | 6.9 | 50 | 4.0 | 29 | 4.0 | 29 | 0.13 | 28 |
| | | | 230 | 60 | 90~1600 | 6.9 | 50 | 4.0 | 29 | 4.0 | 29 | 0.13 | 28 |
| Ⓜ US315-401U | US315-001U | 1/50 15 | 110 | 60 | 90~1600 | 17.4 | 125 | 6.2 | 45 | 7.6 | 55 | 0.47 | 44 |
| | | | 115 | 60 | 90~1600 | 17.4 | 125 | 6.2 | 45 | 7.6 | 55 | 0.50 | 44 |
| Ⓜ US315-402E | US315-002E | 1/50 15 | 220 | 60 | 90~1600 | 11.8 | 85 | 4.9 | 35 | 7.2 | 52 | 0.18 | 39 |
| | | | 230 | 50 | 90~1400 | 17.4 | 125 | 4.9 | 35 | 7.5 | 54 | 0.21 | 43 |
| Ⓜ US315-402E | US315-002E | 1/50 15 | 230 | 60 | 90~1600 | 14.6 | 105 | 4.9 | 35 | 7.6 | 55 | 0.22 | 47 |
| | | | 230 | 60 | 90~1600 | 14.6 | 105 | 4.9 | 35 | 7.6 | 55 | 0.22 | 47 |
| Ⓜ US425-401U | US425-001U | 1/30 25 | 110 | 60 | 90~1600 | 27.8 | 200 | 6.9 | 50 | 14.6 | 105 | 0.74 | 70 |
| | | | 115 | 60 | 90~1600 | 27.8 | 200 | 6.9 | 50 | 14.6 | 105 | 0.74 | 73 |
| Ⓜ US425-402E | US425-002E | 1/30 25 | 220 | 60 | 90~1600 | 18.1 | 130 | 6.0 | 43 | 11.1 | 80 | 0.31 | 59 |
| | | | 230 | 50 | 90~1400 | 26.4 | 190 | 6.5 | 47 | 12.1 | 87 | 0.35 | 62 |
| Ⓜ US425-402E | US425-002E | 1/30 25 | 230 | 60 | 90~1600 | 18.1 | 130 | 6.0 | 43 | 12.1 | 87 | 0.31 | 60 |
| | | | 230 | 60 | 90~1600 | 18.1 | 130 | 6.0 | 43 | 12.1 | 87 | 0.31 | 60 |
| Ⓜ US540-401U | US540-001U | 1/18.5 40 | 110 | 60 | 90~1600 | 36.1 | 260 | 9.7 | 70 | 25.0 | 180 | 1.1 | 102 |
| | | | 115 | 60 | 90~1600 | 36.1 | 260 | 9.7 | 70 | 25.0 | 180 | 1.1 | 105 |
| Ⓜ US540-402E | US540-002E | 1/18.5 40 | 220 | 60 | 90~1600 | 31.9 | 230 | 8.7 | 63 | 17.4 | 125 | 0.55 | 98 |
| | | | 230 | 50 | 90~1400 | 41.7 | 300 | 8.7 | 63 | 19.4 | 140 | 0.53 | 90 |
| Ⓜ US540-402E | US540-002E | 1/18.5 40 | 230 | 60 | 90~1600 | 31.9 | 230 | 8.7 | 63 | 19.4 | 140 | 0.55 | 100 |
| | | | 230 | 60 | 90~1600 | 31.9 | 230 | 8.7 | 63 | 19.4 | 140 | 0.55 | 100 |
| Ⓜ US560-501U | US560-001U | 1/12.5 60 | 110 | 60 | 90~1600 | 68.0 | 490 | 27.8 | 200 | 39.6 | 285 | 2.0 | 178 |
| | | | 115 | 60 | 90~1600 | 68.0 | 490 | 27.8 | 200 | 39.6 | 285 | 2.1 | 186 |
| Ⓜ US560-502E | US560-002E | 1/12.5 60 | 220 | 60 | 90~1600 | 62.5 | 450 | 22.2 | 160 | 29.2 | 210 | 0.86 | 159 |
| | | | 230 | 50 | 90~1400 | 68.0 | 490 | 19.4 | 140 | 33.3 | 240 | 0.89 | 154 |
| Ⓜ US560-502E | US560-002E | 1/12.5 60 | 230 | 60 | 90~1600 | 62.5 | 450 | 22.2 | 160 | 33.3 | 240 | 0.88 | 165 |
| | | | 230 | 60 | 90~1600 | 62.5 | 450 | 22.2 | 160 | 33.3 | 240 | 0.88 | 165 |
| Ⓜ US590-501U | US590-001U | 1/8 90 | 110 | 60 | 90~1600 | 101.4 | 730 | 27.8 | 200 | 56.2 | 405 | 2.6 | 230 |
| | | | 115 | 60 | 90~1600 | 101.4 | 730 | 27.8 | 200 | 56.2 | 405 | 2.6 | 246 |
| Ⓜ US590-502E | US590-002E | 1/8 90 | 220 | 60 | 90~1600 | 101.4 | 730 | 36.1 | 260 | 50.0 | 360 | 1.2 | 221 |
| | | | 230 | 50 | 90~1400 | 101.4 | 730 | 31.9 | 230 | 55.5 | 400 | 1.2 | 201 |
| Ⓜ US590-502E | US590-002E | 1/8 90 | 230 | 60 | 90~1600 | 101.4 | 730 | 36.1 | 260 | 55.5 | 400 | 1.2 | 227 |
| | | | 230 | 60 | 90~1600 | 101.4 | 730 | 36.1 | 260 | 55.5 | 400 | 1.2 | 227 |

- The **US206** type is impedance protected. The other types contain a built-in thermal protector. When a motor overheats for any reason, the thermal protector is opened and the motor stops. When the motor temperature drops, the thermal protector closes and the motor restarts. Be sure to turn off the power before inspecting.
- The speed ranges shown are under no load condition.
- The "U" and "E" at the end of the model number indicate that the unit includes a capacitor. These two letters are not listed on the motor nameplate.

■ General Specifications

| Item | Specifications |
|-------------------------------|---|
| Insulation Resistance | 100MΩ or more when 500V DC is applied between the windings and the frame after rated motor operation under normal ambient temperature and humidity. |
| Dielectric Strength | Sufficient to withstand 1.5kV at 50Hz and 60Hz applied between the windings and the frame after rated motor operation under normal ambient temperature and humidity. |
| Temperature Rise | 144°F (80°C) or less measured by the resistance change method after rated operation of motor with connecting a gearhead or equivalent heat radiation plate. |
| Overheating Protection Device | US206 type is impedance protected. All others have built-in thermal protector (Automatic return type) Operating temperature, open: 266°F±9°F (130°C±5°C) Close: 179.6°F±27°F (82°C±15°C) |
| Insulation Class | Class B (266°F [130°C]) |
| Ambient Temperature Range | 14°F~104°F (-10°C~+40°C) |
| Ambient Humidity | 85% maximum (non condensing) |
| Degree of protection | US206, US315, US425, US540 type: IP20 US560, US590 type: IP40 |

See page A-36 for equivalent heat radiation plate sizes.

Control Unit General Specifications

| Item | Specifications |
|---------------------------|--|
| Insulation Resistance | 100MΩ or more when 500V DC is applied between the windings and the frame. |
| Dielectric Strength | Sufficient to withstand 2.3kV (Single phase 220, 230V: 3.0kV) at 60Hz applied between all the pins and the frame for 1 minute. |
| Ambient Temperature Range | 32°F~104°F (0°C~40°C) |
| Ambient Humidity | 85% maximum (noncondensing) |
| Degree of protection | IP10 |

Speed Range when Gearhead is Attached

Unit = r/min

| Gear Ratio | | 3 | 3.6 | 5 | 6 | 7.5 | 9 | 12.5 | 15 | 18 | 25 | 30 | 36 | 50 | 60 | 75 | 90 | 100 | 120 | 150 | 180 |
|------------|------|-----|-----|-----|-----|-----|-----|------|-----|----|-----|----|-----|-----|-----|-----|----|-----|------|-----|-----|
| High Speed | 50Hz | 466 | 388 | 280 | 233 | 186 | 155 | 112 | 93 | 77 | 56 | 46 | 38 | 28 | 23 | 18 | 15 | 14 | 11 | 9 | 7 |
| | 60Hz | 533 | 444 | 320 | 266 | 213 | 177 | 128 | 106 | 88 | 64 | 53 | 44 | 32 | 26 | 21 | 17 | 16 | 13 | 10 | 8.8 |
| Low Speed | | 30 | 25 | 18 | 15 | 12 | 10 | 7.2 | 6 | 5 | 3.6 | 3 | 2.5 | 1.8 | 1.5 | 1.2 | 1 | 0.9 | 0.75 | 0.6 | 0.5 |

Permissible Torque when Gearhead is Attached

The permissible torque with decimal gearheads are as follows.

2GN□KA/2GN10XK 26 lb-in / 3N-m **3GN□KA/3GN10XK** 43 lb-in / 5N-m

4GN□KA/4GN10XK 69 lb-in / 8N-m (Gear Ratio 25~36 52 lb-in / 6N-m)

5GN□KA/5GN10XK 87 lb-in / 10N-m **5GU□KA/5GU10XKB** 174 lb-in / 20N-m

Right-Angle gearheads may be connected to **US425**, **US540**, **US560** and **US590** types. See page [A-216] for more information.

Single-Phase 115V

Unit = Upper values: lb-in/Lower values: N-m

| Model | Gear Ratio | 3 | 3.6 | 5 | 6 | 7.5 | 9 | 12.5 | 15 | 18 | 25 | 30 | 36 | 50 | 60 | 75 | 90 | 100 | 120 | 150 | 180 |
|--------------------------------------|------------|-------|-------|------|------|------|------|------|------|------|------|------|------|------|-----|-----|-----|-----|-----|-----|-----|
| US206-401U / 2GN□KA | 1200r/min | 1 | 1.3 | 1.7 | 2.1 | 2.6 | 3.1 | 4.4 | 5.2 | 6.3 | 7.9 | 9.4 | 11 | 14 | 17 | 21 | 26 | 26 | 26 | 26 | 26 |
| | 90r/min | 0.12 | 0.15 | 0.2 | 0.24 | 0.3 | 0.36 | 0.51 | 0.61 | 0.73 | 0.91 | 1.1 | 1.3 | 1.7 | 2 | 2.5 | 3 | 3 | 3 | 3 | 3 |
| US315-401U / 3GN□KA | 1200r/min | 0.64 | 0.77 | 1.1 | 1.3 | 1.6 | 1.9 | 2.7 | 3.2 | 3.8 | 4.8 | 5.7 | 6.9 | 8.7 | 10 | 13 | 16 | 17 | 21 | 26 | 26 |
| | 90r/min | 0.073 | 0.087 | 0.12 | 0.15 | 0.18 | 0.22 | 0.3 | 0.36 | 0.44 | 0.55 | 0.66 | 0.79 | 0.99 | 1.2 | 1.5 | 1.8 | 2 | 2.4 | 3 | 3 |
| US425-401U / 4GN□KA | 1200r/min | 2.6 | 3.2 | 4.4 | 5.3 | 6.6 | 7.9 | 11 | 13 | 16 | 20 | 24 | 29 | 36 | 43 | 43 | 43 | 43 | 43 | 43 | 43 |
| | 90r/min | 0.3 | 0.36 | 0.51 | 0.61 | 0.76 | 0.91 | 1.3 | 1.5 | 1.8 | 2.3 | 2.7 | 3.3 | 4.1 | 5 | 5 | 5 | 5 | 5 | 5 | 5 |
| US540-401U / 5GN□KA | 1200r/min | 0.94 | 1.1 | 1.6 | 1.9 | 2.4 | 2.8 | 3.9 | 4.7 | 5.6 | 7.1 | 8.5 | 10 | 13 | 15 | 19 | 23 | 26 | 31 | 38 | 43 |
| | 90r/min | 0.11 | 0.13 | 0.18 | 0.22 | 0.27 | 0.33 | 0.46 | 0.55 | 0.66 | 0.82 | 0.99 | 1.2 | 1.5 | 1.8 | 2.2 | 2.7 | 3 | 3.6 | 4.5 | 5 |
| US560-501U / 5GU□KA | 1200r/min | 4.2 | 5.1 | 7 | 8.4 | 11 | 13 | 18 | 21 | 25 | 32 | 38 | 46 | 57 | 69 | 69 | 69 | 69 | 69 | 69 | 69 |
| | 90r/min | 0.49 | 0.58 | 0.81 | 0.97 | 1.2 | 1.5 | 2 | 2.4 | 2.9 | 3.7 | 4.4 | 5.3 | 6.6 | 7.9 | 8 | 8 | 8 | 8 | 8 | 8 |
| US590-501U / 5GU□KA | 1200r/min | 1 | 1.3 | 1.7 | 2.1 | 2.6 | 3.1 | 4.4 | 5.2 | 6.3 | 7.9 | 9.4 | 11 | 14 | 17 | 21 | 26 | 28 | 34 | 43 | 51 |
| | 90r/min | 0.12 | 0.15 | 0.2 | 0.24 | 0.3 | 0.36 | 0.51 | 0.61 | 0.73 | 0.91 | 1.1 | 1.3 | 1.7 | 2 | 2.5 | 3 | 3.3 | 4 | 5 | 5.9 |
| US540-401U / 5GN□KA | 1200r/min | 5.5 | 6.6 | 9.1 | 11 | 14 | 16 | 23 | 27 | 33 | 41 | 49 | 59 | 74 | 87 | 87 | 87 | 87 | 87 | 87 | 87 |
| | 90r/min | 0.63 | 0.76 | 1.1 | 1.3 | 1.6 | 1.9 | 2.6 | 3.2 | 3.8 | 4.7 | 5.7 | 6.8 | 8.6 | 10 | 10 | 10 | 10 | 10 | 10 | 10 |
| US560-501U / 5GU□KA | 1200r/min | 1.5 | 1.8 | 2.5 | 2.9 | 3.7 | 4.4 | 6.1 | 7.4 | 8.8 | 11 | 13 | 16 | 20 | 24 | 30 | 36 | 40 | 48 | 60 | 72 |
| | 90r/min | 0.17 | 0.2 | 0.28 | 0.34 | 0.43 | 0.51 | 0.71 | 0.85 | 1 | 1.3 | 1.5 | 1.8 | 2.3 | 2.8 | 3.5 | 4.2 | 4.6 | 5.5 | 6.9 | 8.3 |
| US560-501U / 5GU□KA | 1200r/min | 10 | 12 | 17 | 21 | 26 | 31 | 39 | 47 | 56 | 70 | 84 | 101 | 140 | 168 | 174 | 174 | 174 | 174 | 174 | 174 |
| | 90r/min | 1.2 | 1.4 | 2 | 2.4 | 3 | 3.6 | 4.5 | 5.4 | 6.4 | 8.1 | 9.7 | 12 | 16 | 19 | 20 | 20 | 20 | 20 | 20 | 20 |
| US590-501U / 5GU□KA | 1200r/min | 4.2 | 5.1 | 7 | 8.4 | 11 | 13 | 16 | 19 | 23 | 29 | 34 | 41 | 57 | 69 | 77 | 92 | 103 | 123 | 154 | 174 |
| | 90r/min | 0.49 | 0.58 | 0.81 | 0.97 | 1.2 | 1.5 | 1.8 | 2.2 | 2.6 | 3.3 | 4 | 4.8 | 6.6 | 7.9 | 8.9 | 11 | 12 | 14 | 18 | 20 |
| US590-501U / 5GU□KA | 1200r/min | 15 | 18 | 26 | 31 | 39 | 46 | 58 | 69 | 83 | 105 | 125 | 151 | 174 | 174 | 174 | 174 | 174 | 174 | 174 | 174 |
| | 90r/min | 1.8 | 2.1 | 3 | 3.5 | 4.4 | 5.3 | 6.7 | 8 | 9.6 | 12 | 14 | 17 | 20 | 20 | 20 | 20 | 20 | 20 | 20 | 20 |
| US590-501U / 5GU□KA | 1200r/min | 4.2 | 5.1 | 7 | 8.4 | 11 | 13 | 16 | 19 | 23 | 29 | 34 | 41 | 57 | 69 | 77 | 92 | 103 | 123 | 154 | 174 |
| | 90r/min | 0.49 | 0.58 | 0.81 | 0.97 | 1.2 | 1.5 | 1.8 | 2.2 | 2.6 | 3.3 | 4 | 4.8 | 6.6 | 7.9 | 8.9 | 11 | 12 | 14 | 18 | 20 |

● Gearheads and decimal gearheads are sold separately.

● Enter the gear ratio in the box □ within the model number. A colored background indicates gear shaft rotation in the same direction as the motor shaft; a white background indicates rotation in the opposite direction.

● Values for permissible torque are calculated by taking permissible torque at high speed (1200r/min) and low speed (90r/min) and multiplying by gear ratio and gearhead efficiency.

● Single-Phase 220V/230V

Unit = Upper values: lb-in/Lower values: N-m

| Model | Gear Ratio | 3 | 3.6 | 5 | 6 | 7.5 | 9 | 12.5 | 15 | 18 | 25 | 30 | 36 | 50 | 60 | 75 | 90 | 100 | 120 | 150 | 180 | |
|-------------------------------|------------|--------------|---------------|------------|-------------|-------------|-------------|-------------|-------------|-------------|-------------|-------------|-------------|-------------|------------|-----------|-----------|-----------|-----------|-----------|---------|-----|
| US206-402E / 2GN□KA | 1200r/min | 1 0.12 | 1.3 0.15 | 1.7 0.2 | 2.1 0.24 | 2.6 0.3 | 3.1 0.36 | 4.4 0.51 | 5.2 0.61 | 6.3 0.73 | 7.9 0.91 | 9.4 1.1 | 11 1.3 | 14 1.7 | 17 2 | 21 2.5 | 26 3 | 26 3 | 26 3 | 26 3 | 26 3 | |
| | 90r/min | 0.61 0.07 | 0.73 0.085 | 1 0.12 | 1.2 0.14 | 1.5 0.18 | 1.8 0.21 | 2.5 0.29 | 3 0.35 | 3.6 0.42 | 4.6 0.53 | 5.5 0.64 | 6.6 0.76 | 8.3 0.96 | 9.9 1.1 | 12 1.4 | 15 1.7 | 17 1.9 | 20 2.3 | 25 2.9 | 26 3 | |
| US315-402E / 3GN□KA | 1200r/min | 230V | 2.6 | 3.2 | 4.4 | 5.3 | 6.6 | 7.9 | 11 | 13 | 16 | 20 | 24 | 29 | 36 | 43 | 43 | 43 | 43 | 43 | 43 | 43 |
| | | 50Hz | 0.3 | 0.36 | 0.51 | 0.61 | 0.76 | 0.91 | 1.3 | 1.5 | 1.8 | 2.3 | 2.7 | 3.3 | 4.1 | 5 | 5 | 5 | 5 | 5 | 5 | 5 |
| | | 230V | 2.2 | 2.7 | 3.7 | 4.4 | 5.5 | 6.7 | 9.2 | 11 | 13 | 17 | 20 | 24 | 30 | 36 | 43 | 43 | 43 | 43 | 43 | 43 |
| | | 60Hz | 0.26 | 0.31 | 0.43 | 0.51 | 0.64 | 0.77 | 1.1 | 1.3 | 1.5 | 1.9 | 2.3 | 2.8 | 3.5 | 4.2 | 5 | 5 | 5 | 5 | 5 | 5 |
| | 90r/min | 230V | 0.74 | 0.89 | 1.2 | 1.5 | 1.9 | 2.2 | 3.1 | 3.7 | 4.5 | 5.6 | 6.7 | 8 | 10 | 12 | 15 | 18 | 20 | 24 | 30 | 36 |
| | | 60Hz | 0.085 | 0.1 | 0.14 | 0.17 | 0.21 | 0.26 | 0.35 | 0.43 | 0.51 | 0.64 | 0.77 | 0.92 | 1.2 | 1.4 | 1.7 | 2.1 | 2.3 | 2.8 | 3.5 | 4.2 |
| US425-402E / 4GN□KA | 1200r/min | 230V | 2.7 | 3.3 | 4.6 | 5.5 | 6.9 | 8.2 | 11 | 14 | 16 | 21 | 25 | 30 | 37 | 45 | 56 | 67 | 69 | 69 | 69 | 69 |
| | | 60Hz | 0.32 | 0.38 | 0.53 | 0.63 | 0.79 | 0.95 | 1.3 | 1.6 | 1.9 | 2.4 | 2.8 | 3.4 | 4.3 | 5.1 | 6.4 | 7.7 | 8 | 8 | 8 | 8 |
| | | 230V | 4 | 4.8 | 6.7 | 8 | 10 | 12 | 17 | 20 | 24 | 30 | 36 | 43 | 54 | 65 | 69 | 69 | 69 | 69 | 69 | 69 |
| | | 50Hz | 0.46 | 0.55 | 0.77 | 0.92 | 1.2 | 1.4 | 1.9 | 2.3 | 2.8 | 3.5 | 4.2 | 5 | 6.3 | 7.5 | 8 | 8 | 8 | 8 | 8 | 8 |
| | 90r/min | 230V | 0.91 | 1.1 | 1.5 | 1.8 | 2.3 | 2.7 | 3.8 | 4.6 | 5.5 | 6.8 | 8.2 | 9.9 | 12 | 15 | 19 | 22 | 25 | 30 | 37 | 45 |
| | | 60Hz | 0.1 | 0.13 | 0.17 | 0.21 | 0.26 | 0.31 | 0.44 | 0.52 | 0.63 | 0.78 | 0.94 | 1.1 | 1.4 | 1.7 | 2.1 | 2.6 | 2.8 | 3.4 | 4.3 | 5.1 |
| US540-402E / 5GN□KA | 1200r/min | 230V | 4.8 | 5.8 | 8.1 | 9.7 | 12 | 15 | 20 | 24 | 29 | 36 | 44 | 52 | 66 | 79 | 87 | 87 | 87 | 87 | 87 | 87 |
| | | 60Hz | 0.56 | 0.67 | 0.93 | 1.1 | 1.4 | 1.7 | 2.3 | 2.8 | 3.4 | 4.2 | 5 | 6 | 7.6 | 9.1 | 10 | 10 | 10 | 10 | 10 | 10 |
| | | 230V | 6.3 | 7.6 | 11 | 13 | 16 | 19 | 26 | 32 | 38 | 48 | 57 | 68 | 86 | 87 | 87 | 87 | 87 | 87 | 87 | 87 |
| | | 50Hz | 0.73 | 0.87 | 1.2 | 1.5 | 1.8 | 2.2 | 3 | 3.6 | 4.4 | 5.5 | 6.6 | 7.9 | 9.9 | 10 | 10 | 10 | 10 | 10 | 10 | 10 |
| | 90r/min | 230V | 1.3 | 1.6 | 2.2 | 2.6 | 3.3 | 4 | 5.5 | 6.6 | 7.9 | 9.9 | 12 | 14 | 18 | 22 | 27 | 32 | 36 | 43 | 54 | 65 |
| | | 60Hz | 0.15 | 0.18 | 0.26 | 0.31 | 0.38 | 0.46 | 0.64 | 0.77 | 0.92 | 1.1 | 1.4 | 1.7 | 2.1 | 2.5 | 3.1 | 3.7 | 4.2 | 5 | 6.2 | 7.5 |
| US560-502E / 5GU□KA | 1200r/min | 230V | 9.5 | 11 | 16 | 19 | 24 | 28 | 36 | 43 | 51 | 64 | 77 | 93 | 129 | 155 | 173 | 174 | 174 | 174 | 174 | 174 |
| | | 60Hz | 1.1 | 1.3 | 1.8 | 2.2 | 2.7 | 3.3 | 4.1 | 4.9 | 5.9 | 7.4 | 8.9 | 11 | 15 | 18 | 20 | 20 | 20 | 20 | 20 | 20 |
| | | 230V | 10 | 12 | 17 | 21 | 26 | 31 | 39 | 47 | 56 | 70 | 84 | 101 | 140 | 168 | 174 | 174 | 174 | 174 | 174 | 174 |
| | | 50Hz | 1.2 | 1.4 | 2 | 2.4 | 3 | 3.6 | 4.5 | 5.4 | 6.4 | 8.1 | 9.7 | 12 | 16 | 19 | 20 | 20 | 20 | 20 | 20 | 20 |
| | 90r/min | 230V | 3.4 | 4 | 5.6 | 6.7 | 8.4 | 10 | 13 | 15 | 18 | 23 | 27 | 33 | 46 | 55 | 61 | 74 | 82 | 98 | 123 | 147 |
| | | 60Hz | 0.39 | 0.47 | 0.65 | 0.78 | 0.97 | 1.2 | 1.5 | 1.8 | 2.1 | 2.6 | 3.2 | 3.8 | 5.3 | 6.3 | 7.1 | 8.5 | 9.4 | 11 | 14 | 17 |
| US590-502E / 5GU□KA | 1200r/min | 230V | 15 | 18 | 26 | 31 | 39 | 46 | 58 | 69 | 83 | 105 | 125 | 151 | 174 | 174 | 174 | 174 | 174 | 174 | 174 | 174 |
| | | 60Hz | 1.8 | 2.1 | 3 | 3.5 | 4.4 | 5.3 | 6.7 | 8 | 9.6 | 12 | 14 | 17 | 20 | 20 | 20 | 20 | 20 | 20 | 20 | 20 |
| | | 230V | 5.5 | 6.6 | 9.1 | 11 | 14 | 16 | 21 | 25 | 30 | 37 | 45 | 54 | 74 | 89 | 100 | 120 | 133 | 160 | 174 | 174 |
| | | 60Hz | 0.63 | 0.76 | 1.1 | 1.3 | 1.6 | 1.9 | 2.4 | 2.8 | 3.4 | 4.3 | 5.1 | 6.2 | 8.6 | 10 | 12 | 14 | 15 | 18 | 20 | 20 |
| | 90r/min | 230V | 4.8 | 5.8 | 8.1 | 9.7 | 12 | 15 | 18 | 22 | 26 | 33 | 39 | 47 | 66 | 79 | 88 | 106 | 118 | 141 | 174 | 174 |
| | | 60Hz | 0.56 | 0.67 | 0.93 | 1.1 | 1.4 | 1.7 | 2.1 | 2.5 | 3 | 3.8 | 4.6 | 5.5 | 7.6 | 9.1 | 10 | 12 | 14 | 16 | 20 | 20 |

- Gearheads and decimal gearheads are sold separately.
- Enter the gear ratio in the box □ within the model number. A colored background indicates gear shaft rotation in the same direction as the motor shaft; a white background indicates rotation in the opposite direction.
- Values for permissible torque are calculated by taking permissible torque at high speed (1200r/min) and low speed (90r/min) and multiplying by gear ratio and gearhead efficiency.

Torque-Speed Characteristics

US206-401U
US206-001U

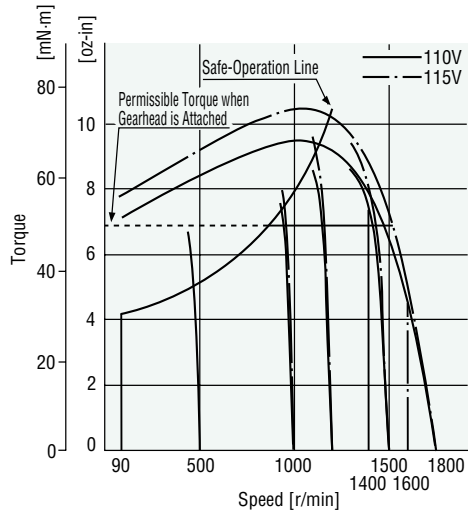

US206-402E
US206-002E

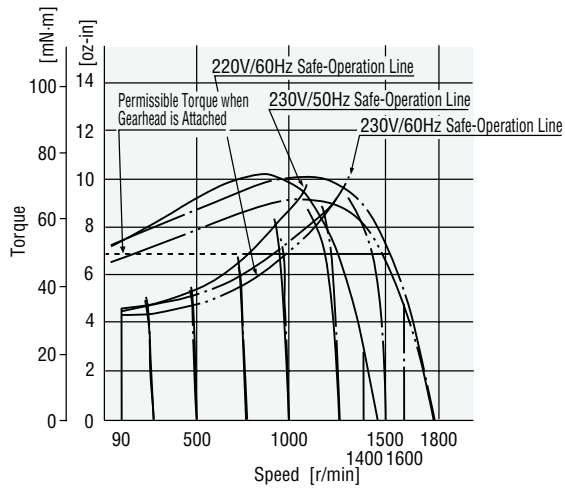

US315-401U
US315-001U

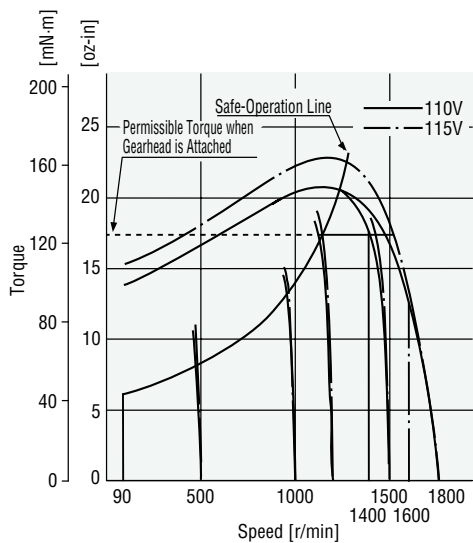

US315-402E
US315-002E

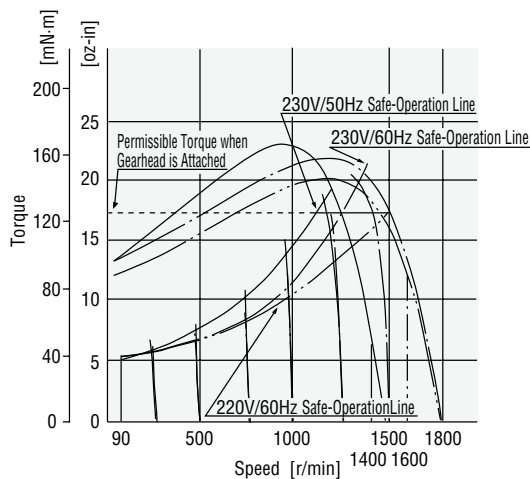

US425-401U
US425-001U

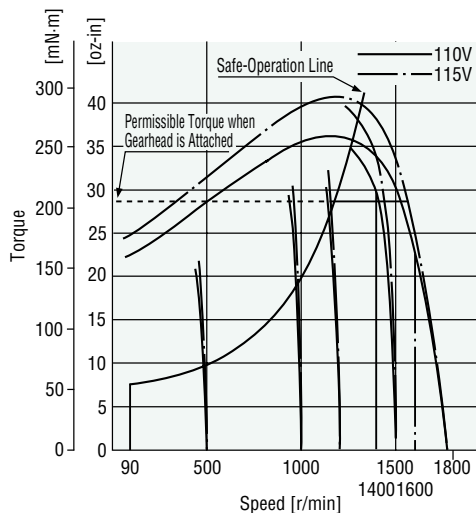

US425-402E
US425-002E

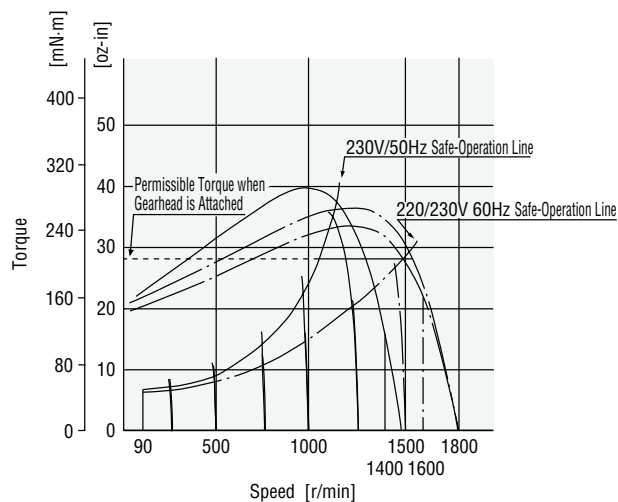

US540-401U
US540-001U

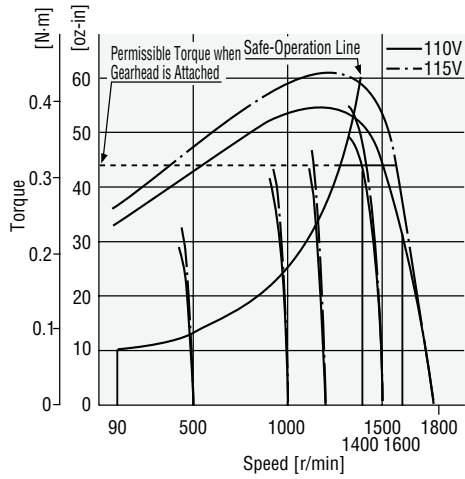

US540-402E
US540-002E

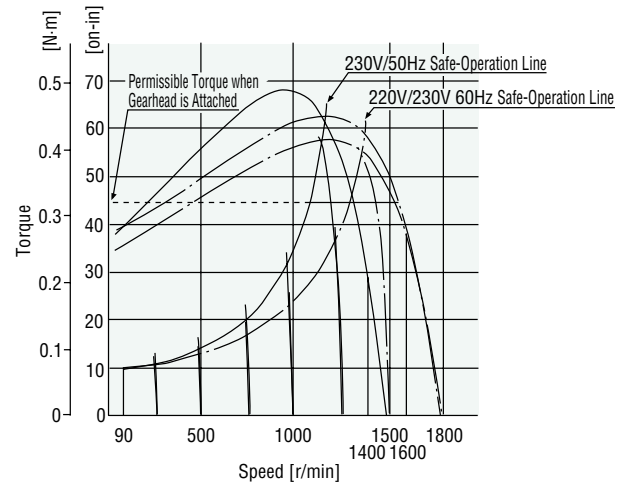

US560-501U
US560-001U

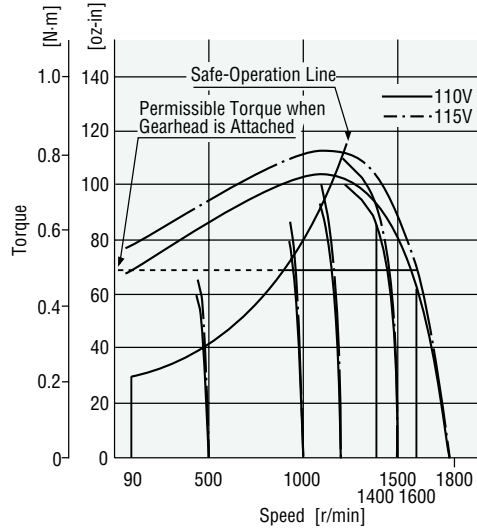

US560-502E
US560-002E

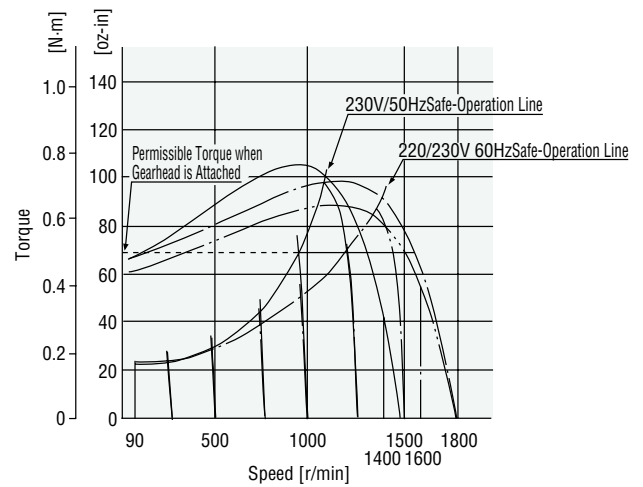

US590-501U
US590-001U

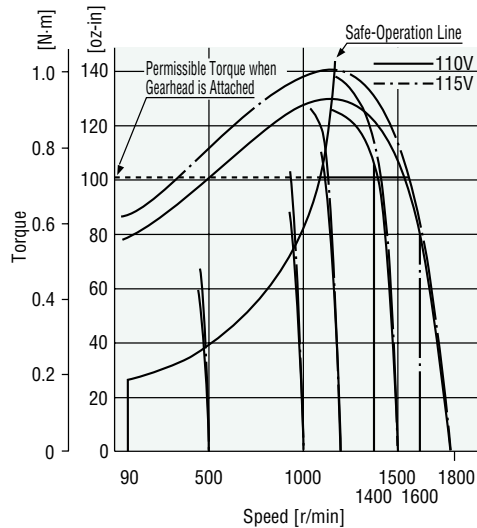

US590-502E
US590-002E

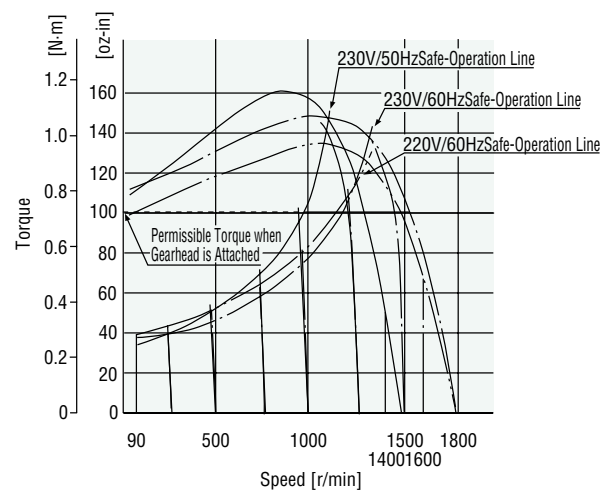

Operation of Speed Control Motor US series

■ Operation

● Rotation

US206, US315, US425 and US540 types

Connect the motor lead wire connectors to the control unit. Then connect the power cord to the power supply. When the RUN/STAND-BY switch of the control unit is flipped to RUN, the motor rotates in the clockwise (CW) direction as seen from the motor shaft.

(Control units are set for clockwise rotation at shipment. The direction of rotation for the gearhead output shaft may be the reverse of the direction of the motor shaft depending on the gear ratio.)

●US560 and US590 types

Connect the control unit and the motor, and attach the capacitor wire leading from the control unit to the capacitor. Next, plug in the power supply cord into an AC power supply. When the RUN/STAND-BY switch located on the control unit is flipped to RUN, the motor will rotate in the direction set by the connection of the capacitor.

(Control units are set for clockwise rotation at shipment. The direction of rotation for the gearhead output shaft may be the reverse of the direction of the motor shaft depending on the gear ratio.)

●Changing Speed

When the potentiometer located on the front surface of the control unit is turned in the clockwise direction, motor speed increases; when turned in the opposite direction, motor speed decreases.

Motor speed can be set and adjusted over a range of 90r/min-1600r/min.

●Stopping

When the RUN/STAND-BY switch on the control unit is set to STAND-BY, the motor stops. This switch is not a power ON/OFF switch. When the motor is to be stopped for a long time, a separate power ON/OFF switch should be installed.

●Changing the Direction of Rotation

US206, US315, US425 and US540 types

(Capacitor is attached to the control unit.)

Uni-directional Rotation

When the direction of motor rotation needs to be reversed for reasons relating to transmission mechanisms such as gearheads, change the terminal used for attaching the power cord, located at the back of control unit, from terminal N (CW) to terminal N (CCW). The power cord connections are located at terminals L and N (CW) when shipping. See the diagram to the right.

(This should always be done with the power OFF.)

Bi-directional Rotation

Install an additional power switch (SW1) and CW/CCW switch (SW2) as shown in the diagram to the right, and use these switches to change the direction of rotation. (Motor cannot be reversed instantaneously. Turn SW1 off and wait until the motor has come to a complete stop before switching SW2.)

See the diagram to the right.

Connecting the Speed Indicator

Connect terminals ① and ⑪ of the **SDM496**, (a digital speed indicator), to the SPEED OUT terminals of control unit.

Control Unit Front Panel

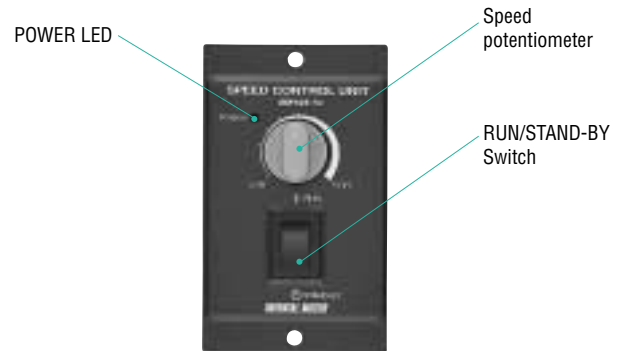

Uni-directional Rotation

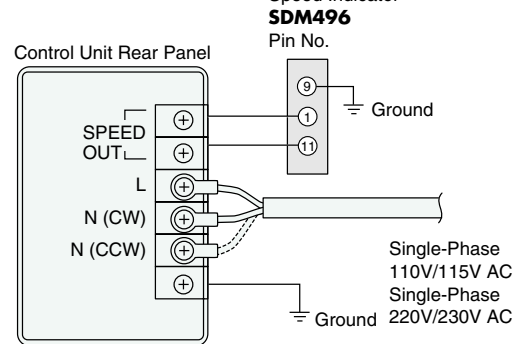

Bi-directional Rotation

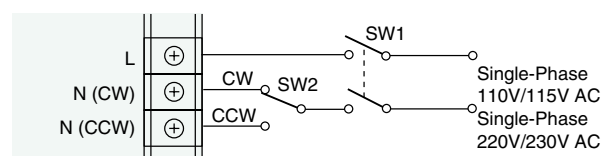

Switch Specification
 Single-Phase 110V/115V: AC250V 5A Min.
 Single-Phase 220V/230V: AC400V 5A Min.

US560 and US590 types

(Connection of capacitor is necessary.)

Uni-directional Rotation

When the direction of motor rotation needs to be reversed, change the terminal used for attaching the power cord, located at the back of control unit, from terminals ④ - ⑤ (CW - COM) to terminals ⑤ - ⑥ (COM - CCW). The power cord connections are located at terminals ④ - ⑤ when shipping. See the diagram to the right.

(This should always be done with the power OFF.)

Bi-directional Rotation

Install an additional power switch (SW1) and CW/CCW switch (SW2) as shown in the diagram to the right, and use these switches to change the direction of rotation. (Motor cannot be reversed instantaneously. Turn SW1 off and wait until the motor has come to a complete stop before switching SW2.)

See the diagram to the right.

Connecting The Speed Indicator

Connect terminals ① and ⑪ of the SDM496, (a digital speed indicator), to the SPEED OUT terminals ① and ② of control unit.

Uni-directional Rotation

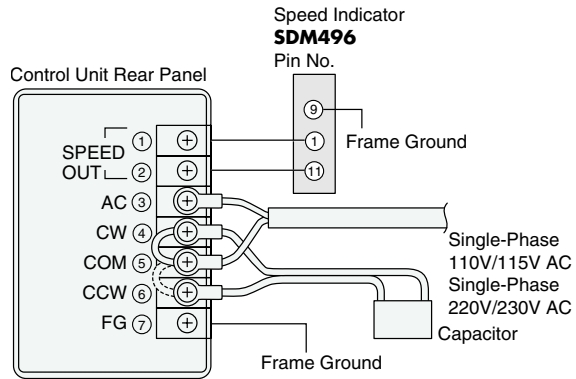

Bi-directional Rotation

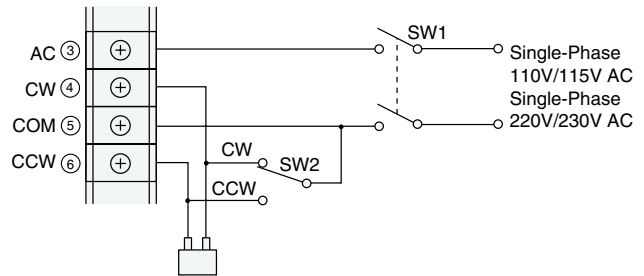

Switch Specification : AC250V 5A Min.
Single-Phase 110V/115V : AC250V 5A Min.
Single-Phase 220V/230V : AC400V 5A Min.

■ Installation Hole for Control Unit

The control unit can be installed from either the front or back of the panel. In either case, the installation hole shown below is required.

1. Installation from front of panel

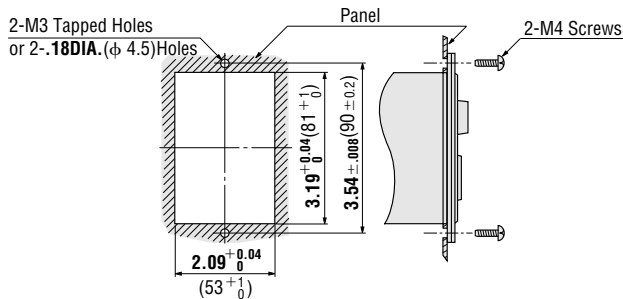

2. Installation from back of panel

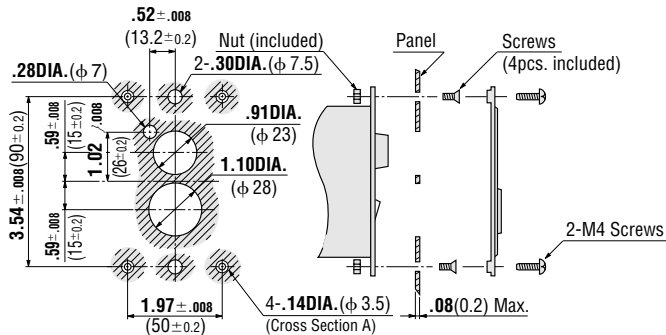

■ Extension Cable (Sold separately)

When installing the motor and control unit in different locations, an extension cable can be used (sold separately). This enables remote operation at a distance of up to 15.7 feet.(4.75m). See page [A-270] for details.

● US206, US315, US425, US540 types

| Model | Length | | Weight | |
|------------------|--------|-----|--------|--------|
| | ft. | (m) | lb. | (kg) |
| CC01SS052 | 3.3 | (1) | 0.22 | (0.10) |
| CC02SS052 | 6.6 | (2) | 0.44 | (0.20) |
| CC03SS052 | 9.8 | (3) | 0.57 | (0.26) |
| CC04SS052 | 13.1 | (4) | 0.77 | (0.35) |

● US560, US590 types

| Model | Length | | Weight | |
|----------------|--------|-----|--------|--------|
| | ft. | (m) | lb. | (kg) |
| CC01SS2 | 3.3 | (1) | 0.37 | (0.17) |
| CC02SS2 | 6.6 | (2) | 0.68 | (0.31) |
| CC03SS2 | 9.8 | (3) | 1.01 | (0.46) |
| CC04SS2 | 13.1 | (4) | 1.28 | (0.58) |

Cross Section A

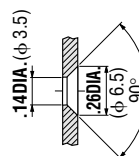

■ Dimensions Scale 1/4, Unit =inch (mm)

US206-401U
US206-402E

Motor USM206-401W Weight (Mass): 1.8 lb. (0.8 kg)

USM206-402W

Gearhead **2GN□KA** Weight (Mass): 0.88 lb. (0.4 kg)
(Sold separately)

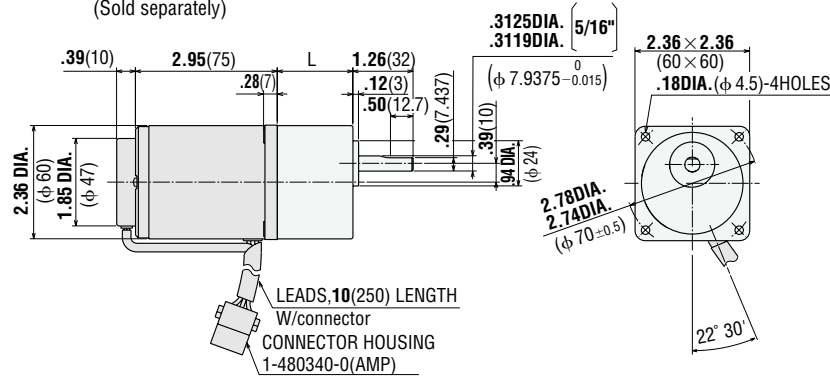

L = 1.18(30) **2GN3KA~18KA**
L = 1.57(40) **2GN25KA~180KA**

US315-401U
US315-402E

Motor USM315-401W Weight (Mass): 2.6 lb. (1.2 kg)

USM315-402W

Gearhead **3GN□KA** Weight (Mass): 1.21 lb. (0.55 kg)
(Sold separately)

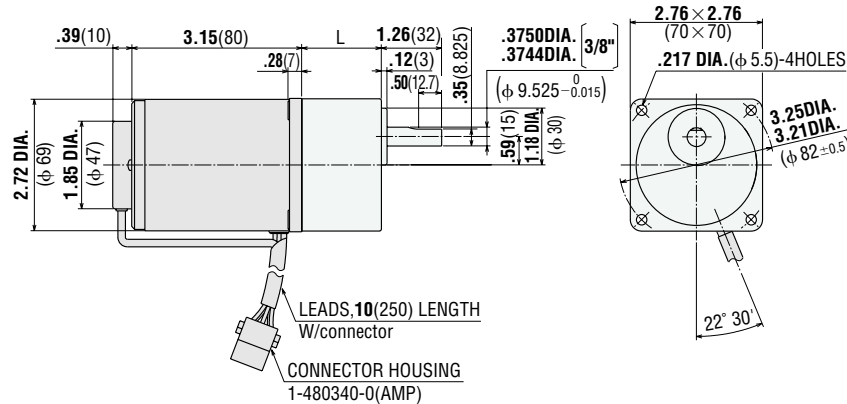

L = 1.26(32) **3GN3KA~18KA**
L = 1.65(42) **3GN25KA~180KA**

US425-401U
US425-402E

Motor USM425-401W Weight (Mass): 3.5 lb. (1.6 kg)

USM425-402W

Gearhead **4GN□KA** Weight (Mass): 1.43 lb. (0.65 kg)
(Sold separately)

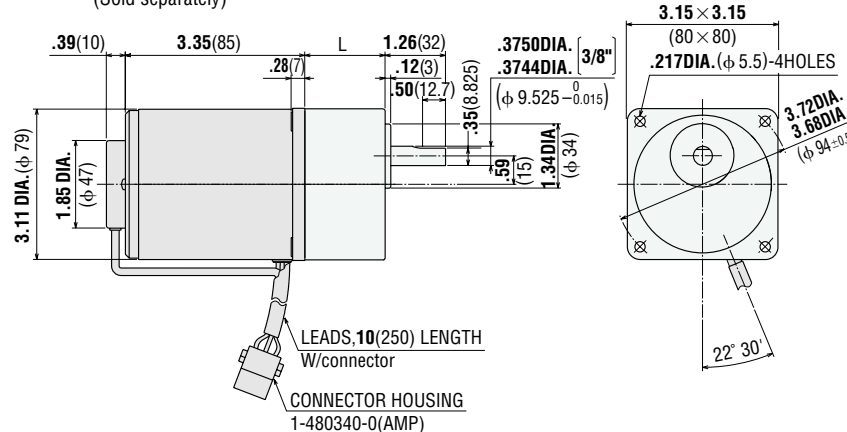

L = 1.26(32) **4GN3KA~18KA**
L = 1.67(42.5) **4GN25KA~180KA**

US206-001U Round shaft

US206-002E

Motor USM206-001W Weight (Mass): 1.8 lb. (0.8 kg)
USM206-002W

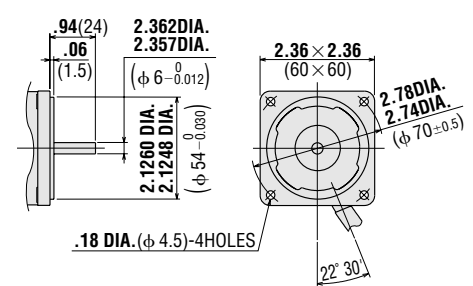

US315-001U Round shaft

US315-002E

Motor USM315-001W Weight (Mass): 2.6 lb. (1.2 kg)
USM315-002W

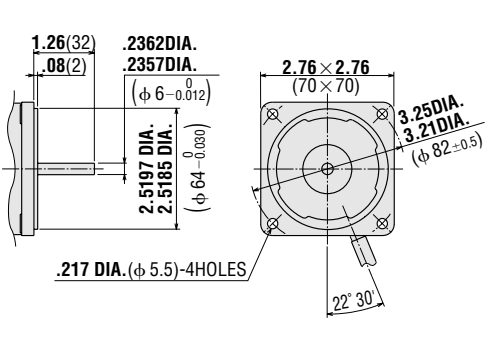

US425-001U (Round shaft)

US425-002E

Motor USM425-001W Weight (Mass): 3.5 lb. (1.6 kg)
USM425-002W

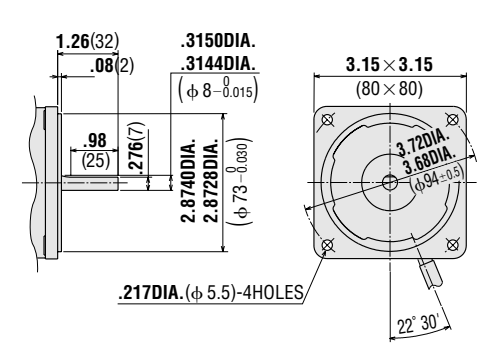

US540-401U

US540-402E

Motor USM540-401W Weight (Mass): 5.7 lb. (2.6 kg)

USM540-402W

Gearhead **5GN□KA** Weight (Mass): 3.3 lb. (1.5 kg)

(Sold separately)

US540-001U (Round shaft)

US540-002E

Motor USM540-001W Weight (Mass): 5.7 lb. (2.6kg)

USM540-002W

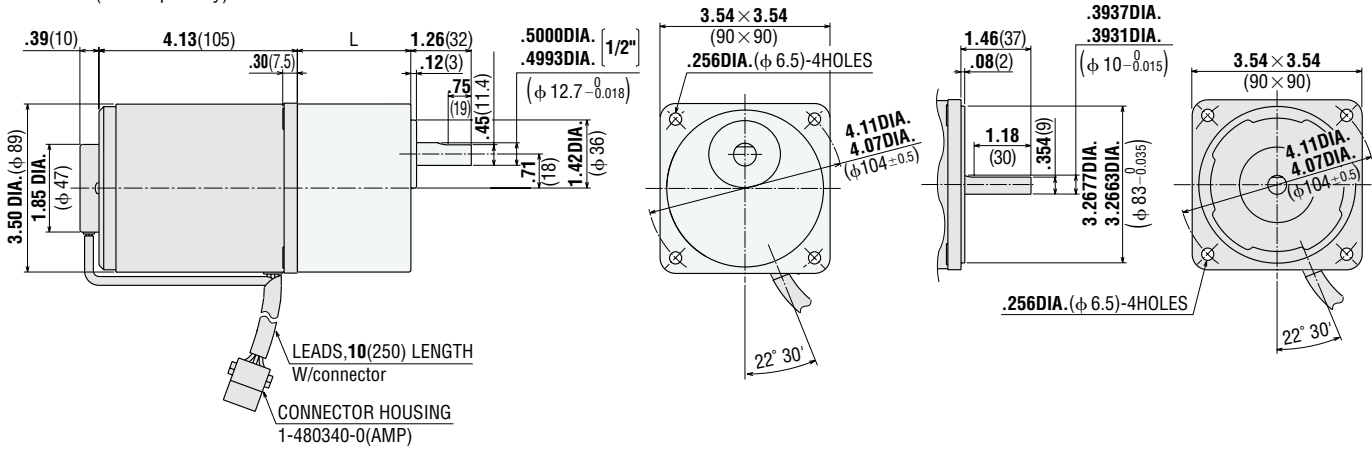

L = 1.65(42) **5GN3KA~18KA**
 L = 2.36(60) **5GN25KA~180KA**

US560-501U

US560-502E

Motor USM560-501W Weight (Mass): 6.2 lb. (2.8 kg)

USM560-502W

Gearhead **5GU□KA** Weight (Mass): 3.3 lb. (1.5 kg)

(Sold separately)

CABTYRE CABLE .441DIA. (φ 11.2)

10(250)LENGTH

CONNECTOR HOUSING:

1-480345-0(AMP)

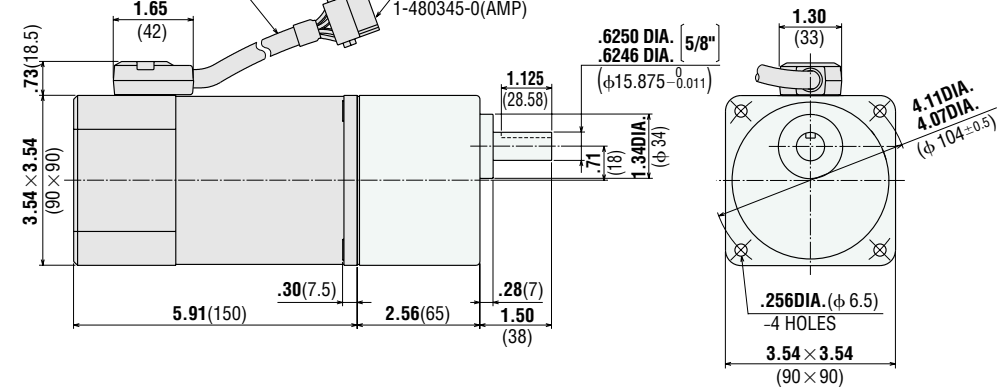

US560-001U (Round Shaft)

US560-002E

Motor USM560-001W Weight (Mass): 6.2 lb. (2.8kg)

USM560-002W

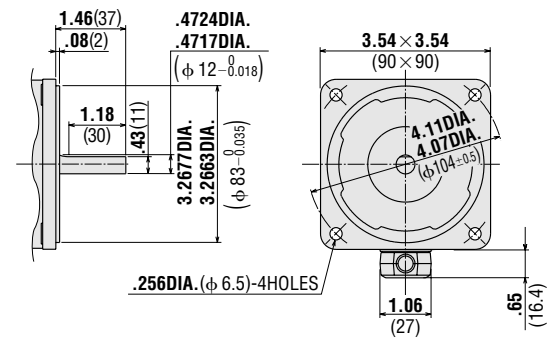

US590-501U
US590-502E

Motor USM590-501W Weight (Mass): 7.9 lb. (3.6 kg)
USM590-502W
Gearhead **5GU□KA** Weight (Mass): 3.3 lb. (1.5 kg)
(Sold separately)

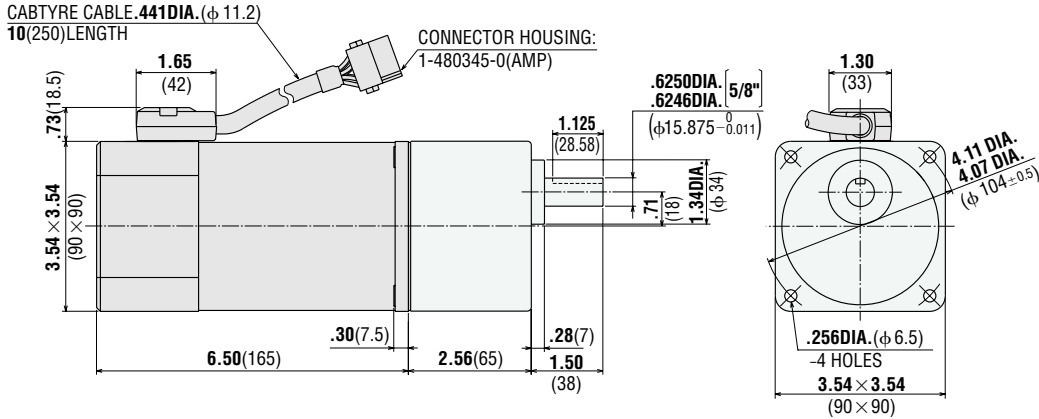

US590-001U (Round shaft)

US590-002E

Motor USM590-001W Weight (Mass) : 7.9 lb. (3.6kg)
USM590-002W

● Key and Key Slot (Scale 1/2)
(included)
5GU□KA

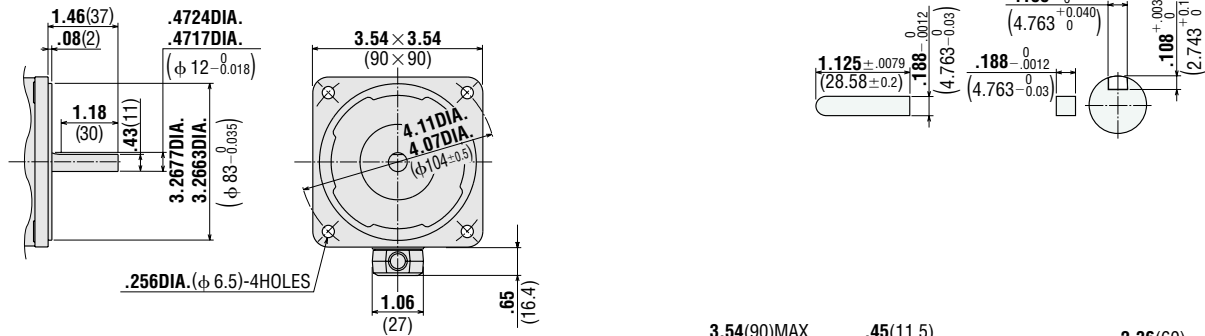

● Control Unit

for **US206, US315, US425** and **US540** types

USP206-1U, USP206-2E
USP315-1U, USP315-2E
USP425-1U, USP425-2E
USP540-1U, USP540-2E
Weight (Mass): 1.0 lb. (0.45kg)

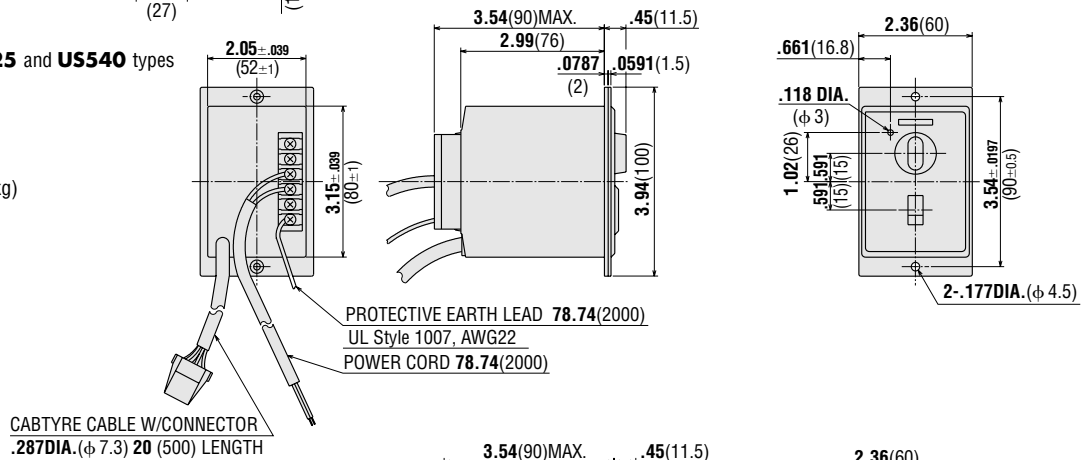

● Control Unit

for **US560** and **US590** type

USP560-1U, USP560-2E
USP590-1U, USP590-2E
Weight (Mass): 1.1 lb. (0.5 kg)

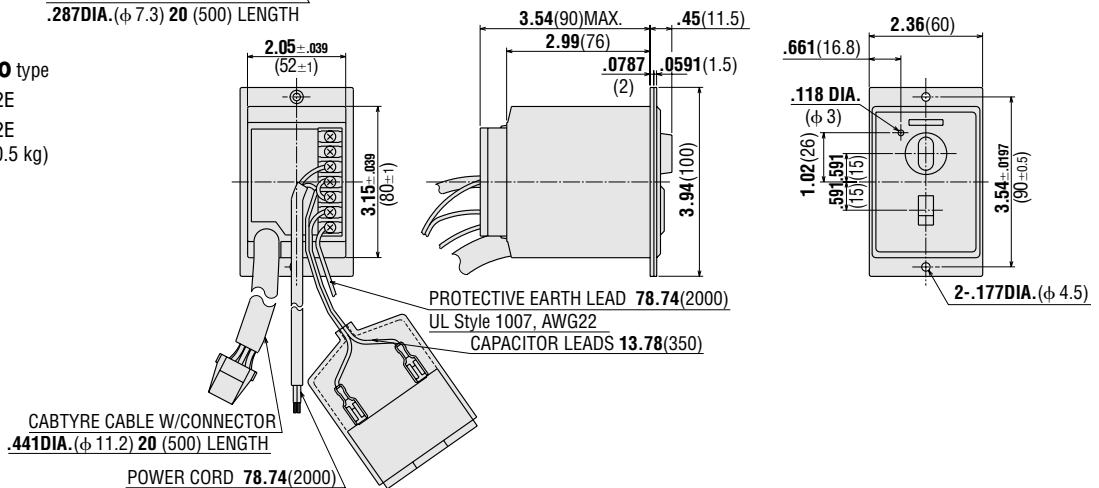

● **Capacitor** (included with the motor)

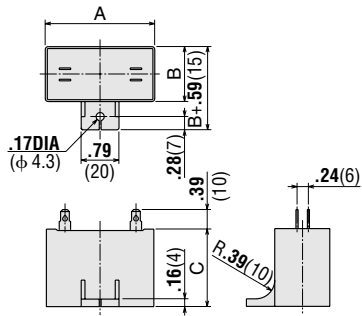

Capacitor Dimensions Unit = inch (mm)

| Unit Model | Capacitor Model | A | B | C | Weight(Mass) oz (g) |
|-------------------|-----------------|-----------|-------------|-----------|------------------------|
| US560-□01U | CH180CFAUL | 2.28 (58) | 0.93 (23.5) | 1.46 (37) | 2.47 (70) |
| US560-□02E | CH40BFAUL | 2.28 (58) | 0.93 (23.5) | 1.46 (37) | 2.47 (70) |
| US590-□01U | CH200CFAUL | 2.28 (58) | 1.14 (29) | 1.61 (41) | 3.35 (95) |
| US590-□02E | CH60BFAUL | 2.28 (58) | 1.14 (29) | 1.61 (41) | 3.00 (85) |

Capacitor cap is provided with the capacitor.

■ **Right-Angle Gearheads (Sold separately)**

The right-angle gearhead provides an output shaft at a right angle to the motor's output shaft. See page[A-216] for specifications and more information.

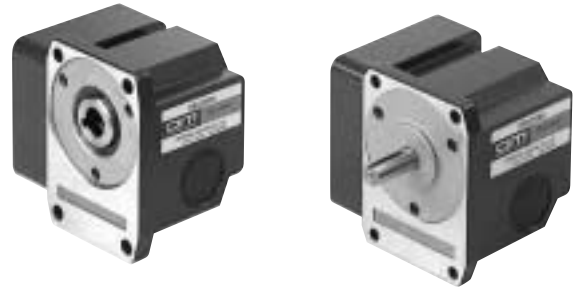

■ **Accessories (Sold separately)**

● **Motor Mounting Brackets**

Optional die-cast aluminum mounting brackets are available. They can be used to install motors without gearheads. See page[A-266] for the dimensions.

| Motor | Model |
|------------------------|----------------|
| for 6W type | SOL2U08 |
| for 15W type | SOL3U10 |
| for 25W type | SOL4U10 |
| for 40W, 60W, 90W type | SOL5UA |



● **Speed Indicator**

To check the speed of speed control motors, connect the speed indicator. See page [A-267] for more information.

Model: **SDM496**



● **Flexible Couplings**

Optional flexible couplings are available. See page [A-260] for more information.



● **Extension Cable**

Extension cable for connecting motor and control unit. See page[A-270] for the dimensions.

SPEED CONTROL MOTORS

COMPONENT *Type* SS21-UL *Type*

A tachogenerator built into induction motors, in combination with the specially designed control pack, allows multi-functional operation such as speed control, and direct control from programmable controllers.

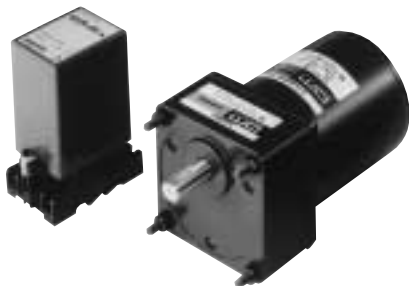

Gearhead shown in photograph is sold separately.



■ Features

- Speed control range is 90 ~ 1700 r/min.
- Each motor and control pack is recognized by UL.
- Easy electrical connections due to the plug-in pin construction.

■ Specifications



| Model | SS21-UL |
|-----------------------------|------------------------------|
| Voltage | AC115V±10% |
| Frequency | 60Hz |
| Current | 1.5A Max. |
| Operable Motor Output Power | 6W~40W |
| Speed Range | 90r/min~1700r/min |
| Ambient Temperature | 32°F~104°F (0°C~40°C) |
| Ambient Humidity | 85% Maximum. (Noncondensing) |

Note that these models cannot be used for applications requiring the control of more than one motor/control-pack set by the same external potentiometer.

■ Specifications

● Induction Motors — Continuous Rating



| Model | | Maximum Output Power Hp | Voltage W | Frequency V AC | Speed Hz | Speed Range r/min | Torque | | Starting Torque | | Current A | Input W | Capacitor | | | |
|---------------------|---------------------|----------------------------|--------------|-------------------|-------------|----------------------|--------------------|-----------------|-----------------|-----------|--------------|------------|-----------|----|-----|-----|
| Pinion Shaft Type | Round Shaft Type | | | | | | oz-in 1200r/min | mN·m 90r/min | oz-in mN·m | μF VAC | | | | | | |
| 2IK6RGN-AUL | 2IK6RA-AULA | 1/124 | 6 | 115 | 60 | 90~1700 | 6.9 | 50 | 2.5 | 18 | 4.6 | 33 | 0.25 | 25 | 2.0 | 250 |
| 3IK15RGN-AUL | 3IK15RA-AULA | 1/50 | 15 | 115 | 60 | 90~1700 | 11.7 | 84.5 | 4.3 | 31 | 8.3 | 60 | 0.46 | 38 | 4.0 | 250 |
| 4IK22RGN-AUL | 4IK22RA-AULA | 1/34 | 22 | 115 | 60 | 90~1700 | 25.0 | 180 | 8.3 | 60 | 15.3 | 110 | 0.52 | 50 | 5.0 | 250 |
| 5IK40RGN-AUL | 5IK40RA-AULA | 1/18.5 | 40 | 115 | 60 | 90~1700 | 25.0 | 180 | 7.6 | 55 | 27.8 | 200 | 0.83 | 58 | 8.0 | 250 |

- **2IK** type is impedance protected.
- **3IK, 4IK** and **5IK** type motors contain a built-in thermal protector. If a motor overheats for any reason, the thermal protector is opened and the motor stops. When the motor temperature drops, the thermal protector closes and the motor restarts. Be sure to turn the motor off before inspecting.
- The speed range is under no load condition.
- The UL recognized speed control motors are designed for the SS21-UL type speed control pack. Motor cannot be combined with other types of control packs.
- Note that these models cannot be used for applications requiring the control of more than one motor/control-pack set by the same external potentiometer.

■ General Specifications of Motors

| Item | Specifications |
|-------------------------------|---|
| Insulation Resistance | 100M ohms or more when 500V DC is applied between the windings and the frame after rated motor operation under normal ambient temperature and humidity. |
| Dielectric Strength | Sufficient to withstand 1.5kV at 50Hz and 60Hz applied between the windings and the frame after rated motor operation under normal ambient temperature and humidity. |
| Temperature Rise | 135°F (75°C) or less measured by the resistance change method after the temperature of the coil has stabilized under normal operation at the rated voltage and frequency. |
| Overheating Protection Device | Built-in thermal protector (Automatic return type) Open: 248°F±9°F (120°C±5°C) Close: 170.6°F±27°F (77°C ±15°C) |
| Insulation Class | Class A |
| Ambient Temperature Range | 14°F ~ 104°F (-10°C ~ +40°C) |
| Ambient Humidity | 85% Maximum (Noncondensing) |

- **2IK** type is impedance protected. This type of motor does not contain a built-in thermal protector.

■ Permissible Torque When Gearhead Is Attached

The speed at gearhead shaft (N_G) is calculated as follows:

$$N_M = N_G \times i$$

N_M : Speed of Motor
 N_G : Speed of Gearhead
 i : Gear Ratio

The output torque at gearhead (T_G) is calculated by using the following formula:

$$T_G = T_M \times i \times \eta$$

T_G : Permissible Torque of Gearhead
 T_M : Permissible Torque of Motor
 η : Gearhead efficiency (refer to Table 2)

The output torque at the gearhead shaft must be lower than the maximum permissible torque specified right.

Maximum Permissible Torque of Gearhead

| Gearhead Model | Maximum Permissible Torque |
|----------------|---|
| 2GN□KA | 26 lb-in/3 N·m |
| 3GN□KA | 43 lb-in/5 N·m |
| 4GN□KA | 69 lb-in/8 N·m (52 lb-in/6 N·m when gear ratio is 250, 300 and 360) |
| 5GN□KA | 87 lb-in/10 N·m |

- Enter the gear ratio in the box (□) within the model name.

● **Table 1: Motor Speed Range**

| Gear Ratio | 3 | 3.6 | 5 | 6 | 7.5 | 9 | 12.5 | 15 | 18 | 25 | 30 | 36 | 50 | 60 | 75 | 90 | 100 | 120 | 150 | 180 | |
|-------------|-----|-----|-----|-----|-----|-----|------|-----|----|-----|----|-----|-----|-----|-----|-----|-----|------|-----|-----|---|
| High Speed | 566 | 472 | 340 | 283 | 226 | 189 | 136 | 113 | 94 | 68 | 56 | 47 | 34 | 28 | 22 | 19 | 17 | 14 | 11 | 9.4 | |
| Speed r/min | } | } | } | } | } | } | } | } | } | } | } | } | } | } | } | } | } | } | } | } | } |
| Low Speed | 30 | 25 | 18 | 15 | 12 | 10 | 7 | 6 | 5 | 3.6 | 3 | 2.5 | 1.8 | 1.5 | 1.2 | 1.0 | 0.9 | 0.75 | 0.6 | 0.5 | |

● **Table 2: Gearhead Efficiency and Direction of Gearhead Output Shaft**

| Gear Ratio | 3 | 3.6 | 5 | 6 | 7.5 | 9 | 12.5 | 15 | 18 | 25 | 30 | 36 | 50 | 60 | 75 | 90 | 100 | 120 | 150 | 180 |
|-----------------------|-----|-----|---|---|-----|---|------|----|----|-----|----|----|-----|----|----|----|-----|-----|-----|-----|
| Model | | | | | | | | | | | | | | | | | | | | |
| 2GN□KA, 3GN□KA | 81% | | | | | | | | | 73% | | | 66% | | | | | | | |
| 4GN□KA, 5GN□KA | 81% | | | | | | | | | 73% | | | 66% | | | | | | | |

- A colored background indicates that the output shaft of the gearmotor rotates in the same direction as the output shaft of the motor. A white background indicates rotation in the opposite direction.
- Enter the gear ratio in the box (□) within the model name.

Torque — Speed Characteristics

2IK6RGN-AUL
2IK6RA-AULA
 / **SS21-UL**

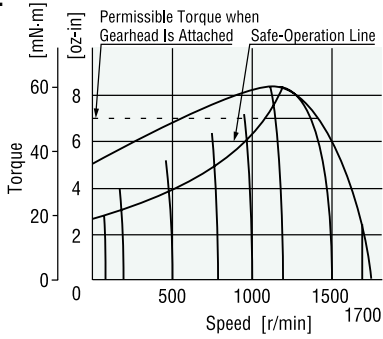

4IK22RGN-AUL
4IK22RA-AULA
 / **SS21-UL**

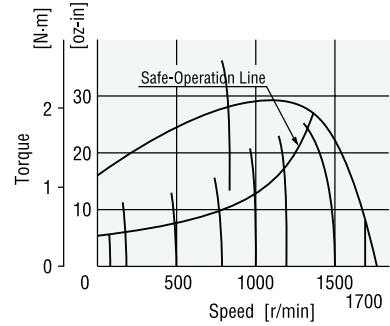

3IK15RGN-AUL
3IK15RA-AULA
 / **SS21-UL**

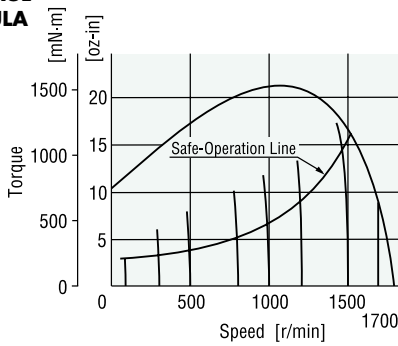

5IK40RGN-AUL
5IK40RA-AULA
 / **SS21-UL**

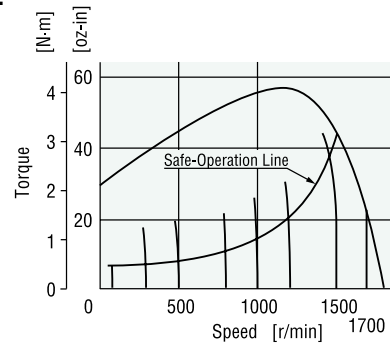

Wiring Diagrams

Uni-directional, speed control

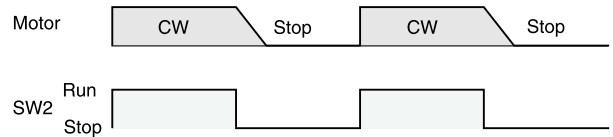
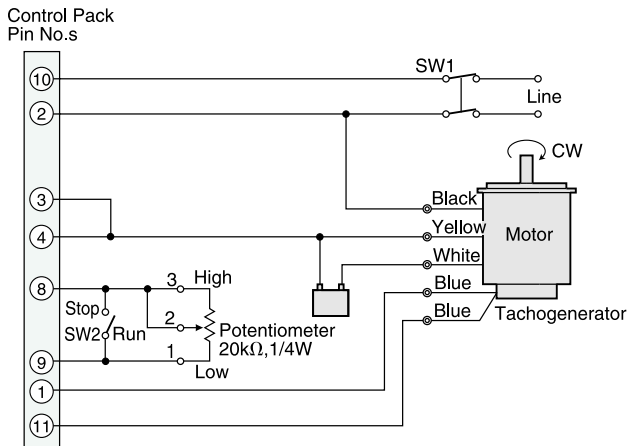

- To stop the motor for an extended period, use SW2.
- This wiring diagram provides CW rotation as viewed from the front shaft end of the motor.
- To reverse direction (CCW), reverse the yellow and white wires.
- The direction of rotation is as view from the front shaft end the motor.

● Bi-directional, speed control

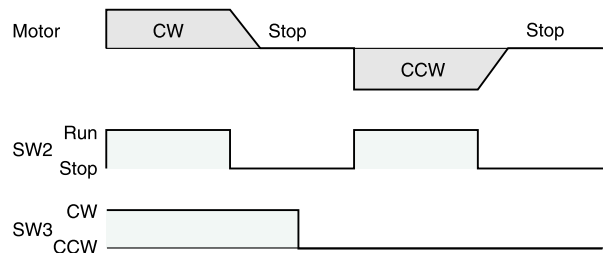
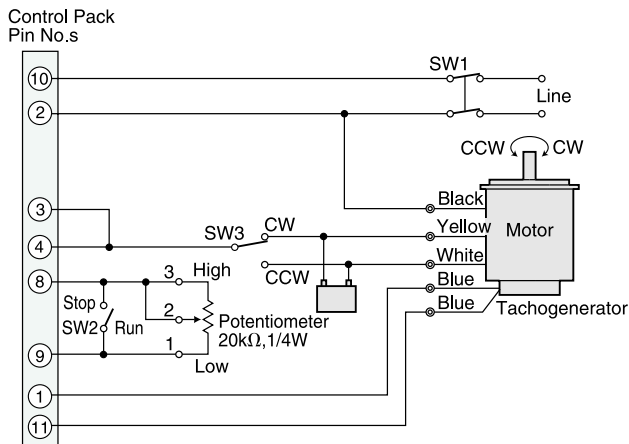

- To stop the motor for an extended period, use SW1.
- SW3 controls the direction of motor shaft rotation as viewed from the front shaft end of the motor. Change the direction of motor rotation only after bringing the motor to a stop. If an attempt is made to change the direction of rotation while the motor is rotating, the motor may ignore the reversing command or change its direction of rotation after some delay.
- To reverse direction of motor rotation, wait until the motor has stopped.
- The direction of rotation is as view from the front shaft end the motor.

| Switch No. | Specifications | Accessories |
|------------|---------------------|-------------|
| SW1, SW3 | AC125V, 5A minimum | — |
| SW2 | DC20V, 10mA minimum | — |

■ Speed Control

● Setting The Speed

The speed is set by either an external potentiometer. These values correspond to the minimum and the maximum setting of the speed potentiometer used for speed control. Motor speed can be adjusted over the range from 90 r/min to 1700 r/min at 60Hz.

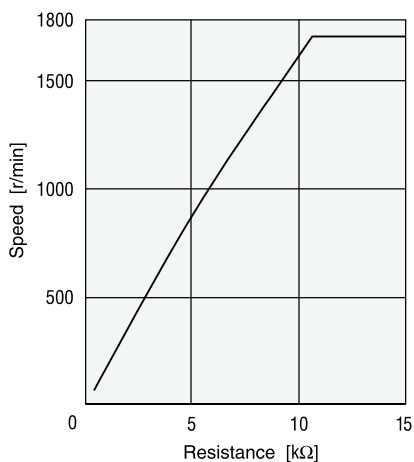

Speed Setting Resistance — Speed Characteristics

Note: The speed control inputs of the control packs must be isolated from each other. Therefore, only one control pack at a time can be controlled by a single potentiometer.

■ Dimensions Scale 1/4, Unit = inch (mm)

2IK6RGN-AUL

Weight (Mass): 1.76 lb.(0.8 kg)

2GN□KA

Weight (Mass): 0.88 lb.(0.4 kg)

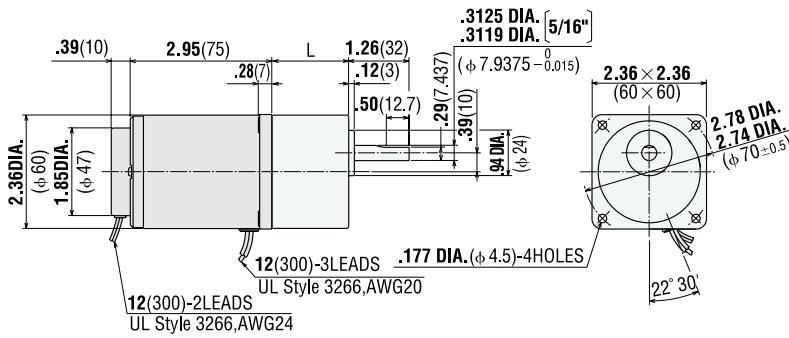

L=1.18 (30) **2GN3KA~18KA**
L=1.57 (40) **2GN25KA~180KA**

2IK6RA-AULA

Weight (Mass): 1.76 lb.(0.8 kg)

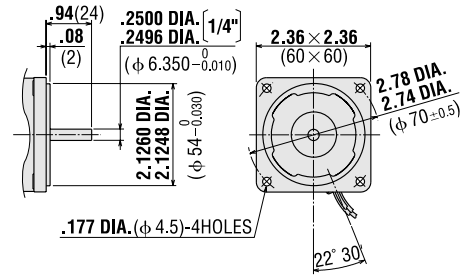

3IK15RGN-AUL

Weight (Mass): 2.65 lb.(1.2 kg)

3GN□KA

Weight (Mass): 1.21 lb.(0.55 kg)

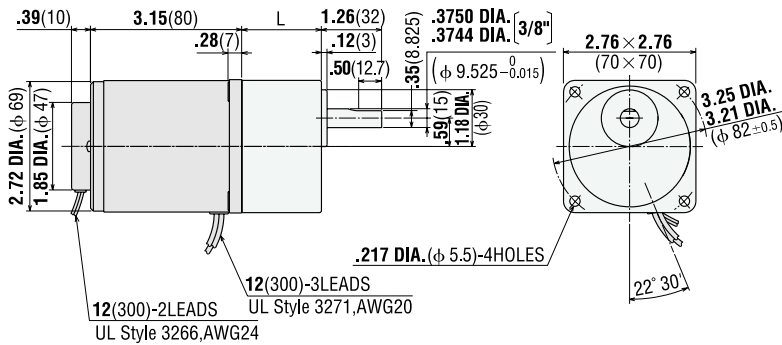

L=1.26 (32) **3GN3KA~18KA**
L=1.65 (42) **3GN25KA~180KA**

3IK15RA-AULA

Weight (Mass): 2.65 lb.(1.2 kg)

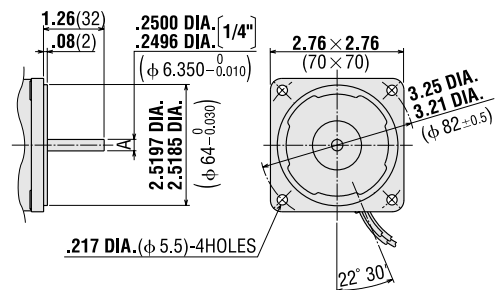

4IK22RGN-AUL

Weight (Mass): 3.53 lb.(1.6 kg)

4GN□KA

Weight (Mass): 1.43 lb.(0.65 kg)

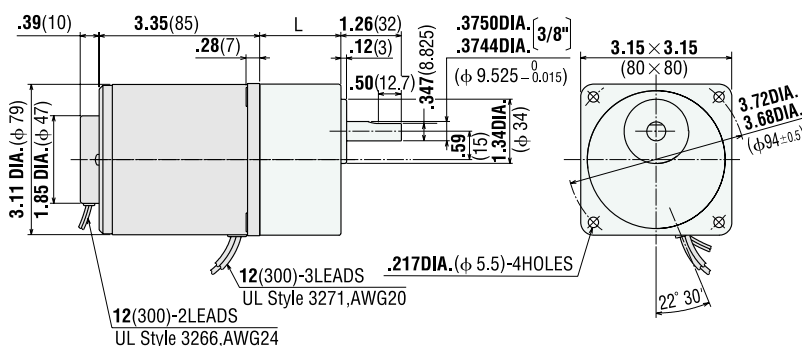

L=1.26 (32) **4GN3KA~18KA**
L=1.67 (42.5) **4GN25KA~180KA**

4IK22RA-AULA

Weight (Mass): 3.53 lb.(1.6 kg)

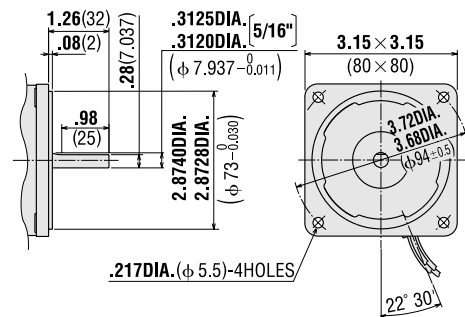

5IK40RGN-AUL

Weight (Mass): 5.73 lb.(2.6 kg)

5GN□KA

Weight (Mass): 3.3 lb.(1.5 kg)

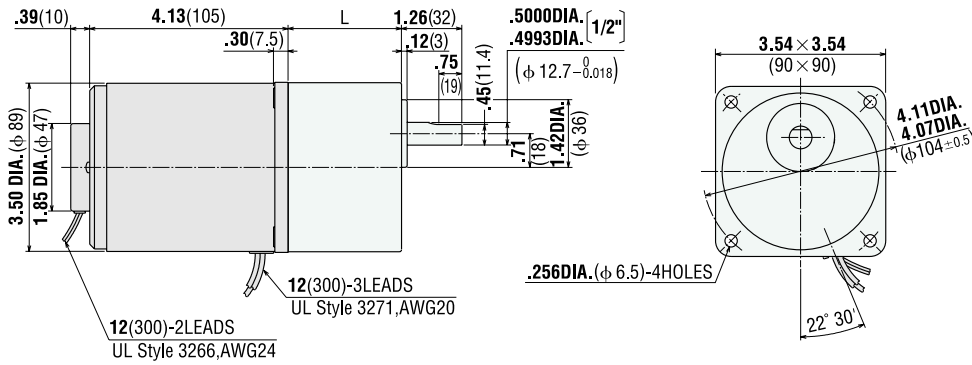

L=1.65 (42) **5GN3KA~18KA**
L=2.36 (60) **5GN25KA~180KA**

5IK40RA-AULA

Weight (Mass): 5.73 lb.(2.6 kg)

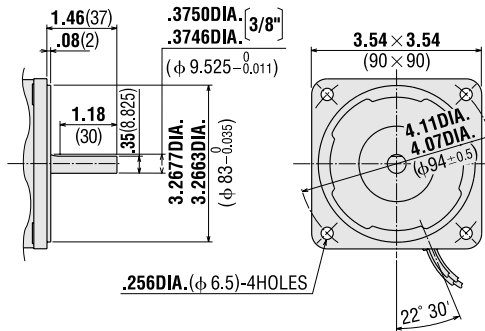

● **Capacitor** (included with the motor)

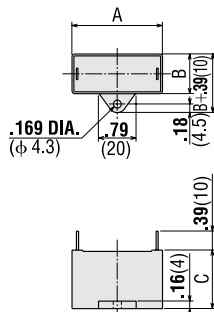

| Motor Model | Capacitor Model | Dimensions inch (mm) | | | Weight oz (g) |
|---------------------|-----------------|----------------------|--------|--------|---------------|
| | | A | B | C | |
| 2IK6RGN-AUL | CH20UL | 1.22 | .57 | .93 | 0.53 15 |
| 2IK6RA-AULA | | (31) | (14.5) | (23.5) | |
| 3IK15RGN-AUL | CH40UL | 1.46 | .71 | 1.06 | 0.88 25 |
| 3IK15RA-AULA | | (37) | (18) | (27) | |
| 4IK22RGN-AUL | CH50UL | 1.50 | .75 | 1.14 | 1.06 30 |
| 4IK22RA-AULA | | (38) | (19) | (29) | |
| 5IK40RGN-AUL | CH80UL | 1.50 | .83 | 1.22 | 1.23 35 |
| 5IK40RA-AULA | | (38) | (21) | (31) | |

Capacitor cap is provided with the capacitor.

■ **Speed Control Pack Dimensions**

Scale 1/4, Unit = inch (mm)

SS21-UL Weight (Mass): 0.33 lb.(0.15 kg)

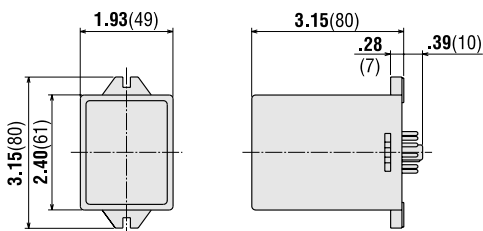

● **Potentiometer**

PAVR-20KY Scale 1/2, Unit = inch (mm)

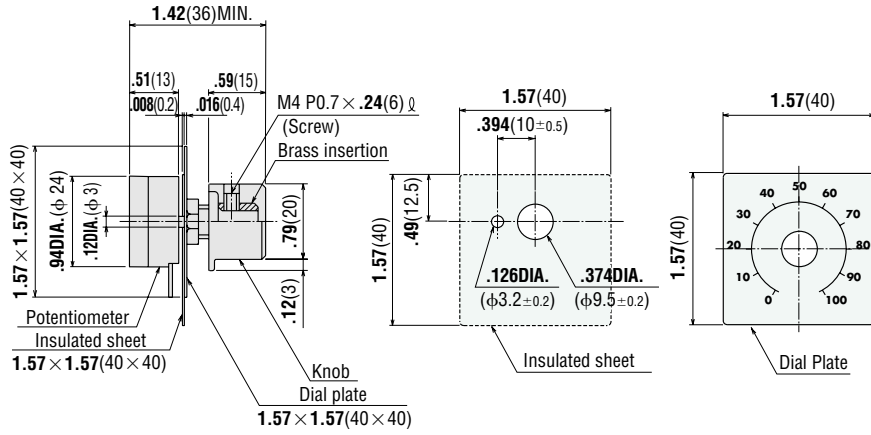

● **Socket**

EP11PF Scale 1/4, Unit = inch (mm)

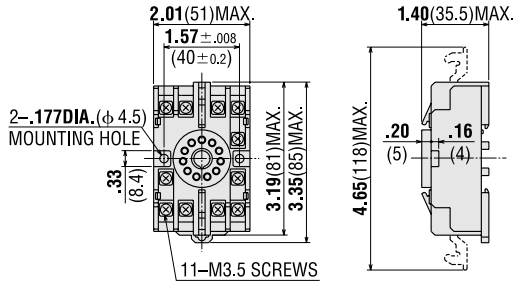

■ **Accessories (Sold separately)**

● **Speed Indicator**

To check the motor speed visually, connect a speed indicator, model **SDM496** (sold separately). See page A-269 for more detail.



SDM496 can also indicate the speed at the gearhead shaft.

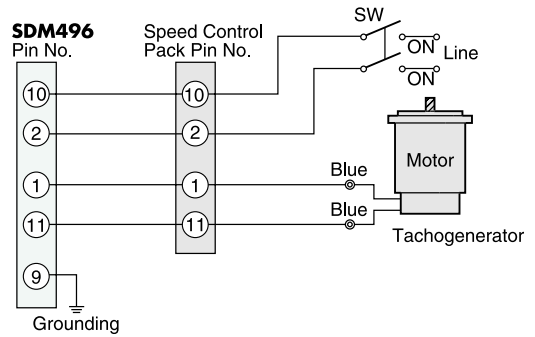

ORIENTAL MOTOR GENERAL CATALOG



Brake Motors

Types and Features of Brake MotorsA-178
 Electromagnetic Brake MotorsA-180
 Clutch and Brake MotorsA-194

Types and Features of Brake Motors

■ Overview

When using a motor as the drive force to perform uni-directional or bi-directional operation, there is often a need to stop the motor quickly or to hold the load in position while the motor is stopped.

With induction motors, it generally takes 30~40 revolutions (at motor shaft) from the time the switch is turned off until the motor actually stops. With reversible motors there is an overrun of 5~6 revolutions (at motor shaft). Use of a brake motor is recommended when the motor needs to be stopped more quickly.

Load holding applications can use an electromagnetic brake. An electromagnetic brake is activated when the power is shut off. Since electromagnetic brakes exert holding power even while the power is off, they are highly suitable for use as emergency brakes.

For applications where the motor is started and stopped more than 100 times per minute, the clutch and brake motor is the ideal choice. This motor is equipped with an electromagnetic clutch and brake mechanism, giving it powerful braking and holding force. Overrun during braking is less than a revolution. With **C•B** motors, the motor is kept running continuously, and because starts and stops are controlled by the clutch and brake, the motor is capable of excellent response.

■ Types of Brake Motors

When holding brake force is required **Electromagnetic Brake Motors**

A-180

- Single-Phase 110V/115VAC, Single-Phase 220V/230VAC, Three-phase 200V/220V/230VAC
- 6W, 15W, 25W, 40W, 60W, 90W

These motors are directly coupled to an AC electromagnetic brake which is activated when power is not applied. When the power supply is turned off, the motor comes instantaneously to a stop and holds the load. Holding brake force can be up to 69.4 oz-in (500 mN·m) (60W, 90W). Since the holding brake force works when the power supply has been turned off, these units are excellent as emergency brakes.



Suitable for high-frequency operation. **Clutch and Brake Motors**

A-194

- Single-Phase 110V/115VAC
- Output Power 40W, 60W, 90W
- Induction Motor

This compact AC motor utilizes a clutch and brake unit to permit frequent starting and stopping with an excellent response. Another important feature is its maximum holding and braking power of 208 oz-in (1500 mN·m).



■ Calculating Inertia (J)

When the electromagnetic brake motor is used, the inertia of the load greatly affects stopping time, overrun and stopping accuracy. The inertia J [oz-in²] is used in the selection of electromagnetic brake motors.

The table to the right shows the equations used to calculate J for various load shapes. When a gearhead is used to reduce speed, the J equivalent for the motor shaft is $\frac{1}{(\text{Gear Ratio})^2}$.

$$J_M = \frac{1}{i^2} J_L \text{ [oz-in}^2\text{]}$$

J_M : J equivalent at motor shaft

J_L : J of load on gearhead shaft

i : Gear ratio of gearhead

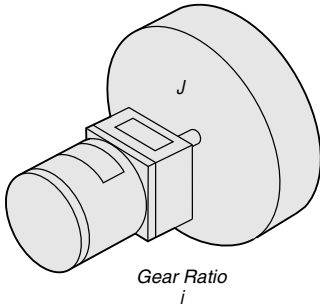

For example, if a gearhead with a gear ratio of 18:1 is used and the load inertia (J_L) is 250 oz-in², the equivalent inertia at the motor shaft is:

$$J_M = \frac{1}{18^2} \times 250 \approx 0.8 \text{ [oz-in}^2\text{]}$$

Inertia (J) for Various Load Shapes

W : Weight [oz]

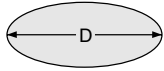
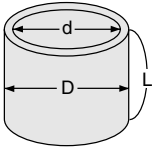
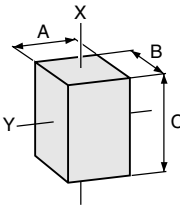
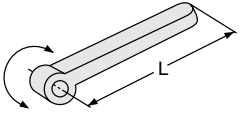
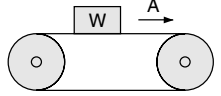
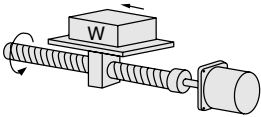
| Shape | J [oz-in ²] |
|---|--|
| Solid Disk  | Relative to center axis: $\frac{1}{8} WD^2$ |
| Annular Cylinder  | Relative to center axis: $\frac{1}{8} W(D^2 + d^2)$ |
| Square Post  | Relative to X axis: $\frac{1}{12} W(A^2 + B^2)$ Relative to Y axis: $\frac{1}{12} W(B^2 + C^2)$ |
| Straight Bar  | $\frac{1}{3} WL^2$ |
| Belt Drive (Horizontal Movement)  <p>A: Distance moved per rotation [inch]</p> | $\frac{W \cdot A^2}{4\pi^2}$ (Does not include J of pulley belt) |
| Ball Screw Drive  | $J_i + \frac{WP^2}{4\pi}$ J_i : J of ball screw [oz-in ²] P : Ball screw pitch [inch] W : Total Weight of table and work [oz] |

Electromagnetic Brake Motors

This power off, electromagnetic brake coupled to reversible motors and induction motors (three-phase type) provides output of 6W~90W (three-phase: 25W~90W). These motors are best suited for applications in which loads must be held.



■ Features

- These motors incorporate AC electromagnetic brakes which are activated when the power is shut off. When the power supply is turned off the motor stops and holds the load. Holding brake force is 4.2 oz-in (30 mN·m) ~ 69.4 oz-in (500 mN·m). These units are excellent as emergency safety brakes.

■ Structure

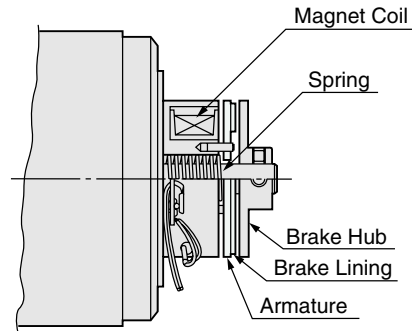

The figure above indicates an example of the structure of the electromagnetic brake motor.

The electromagnetic brake operates on the basis of a spring which presses the armature against the brake hub, stopping the motor and holding the load. When the electromagnetic brake is excited, it attracts the armature and the brake lining is pulled away from the brake hub. The motor is able to turn freely.



■ Safety Standards and CE Marking

● For -AWMU, -CWME, -SWM Type

| Standards | Certification Body | Standards File No. | CE Marking |
|--|--|---|-----------------------|
| UL1004 UL519 (6W) UL547 (15W-90W) CAN/CSA-C22.2 No.100 CAN/CSA-C22.2 No.77 | UL | E64199 (6W) E64197 (15W~90W) | Low Voltage Directive |
| EN60950 | | VDE 114919ÜG (6W) 6751ÜG (15W-90W) DEMKO 124234/DK99-00431 (Three-phase 90W) | |
| EN60034-1 EN60034-5 IEC60034-11 | Conform to EN/IEC Standards (EN/IEC certifications are scheduled) | | |

- Recognized name and certified name of each safety standards are motor model name.

● For -AMUL Type

| Standards | Certification Body | Standards File No. | CE Marking |
|--|--------------------|---|-----------------------|
| UL1004 UL519 (6W) UL547 (15W-90W) CAN/CSA-C22.2 No.100 CAN/CSA-C22.2 No.77 | UL | E64199 (6W) E64197 (15W~90W) | Low Voltage Directive |
| EN60950 | CSA | LR47296 | |
| | VDE | 5875ÜG (6W) 5872ÜG (15, 25W) 5873ÜG (40W) 5874ÜG (60, 90W) | |

- For installation condition for EN/IEC standards, see page D-2.

■ Construction

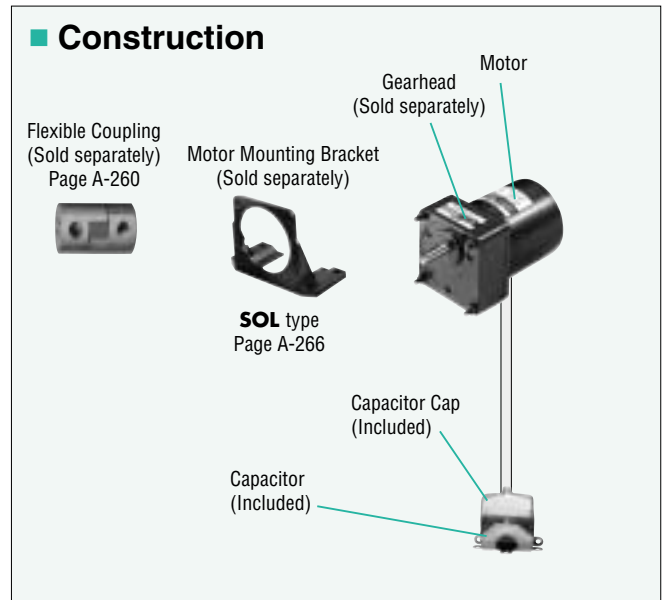

■ Product Number Code

4RK25GN - AW M U

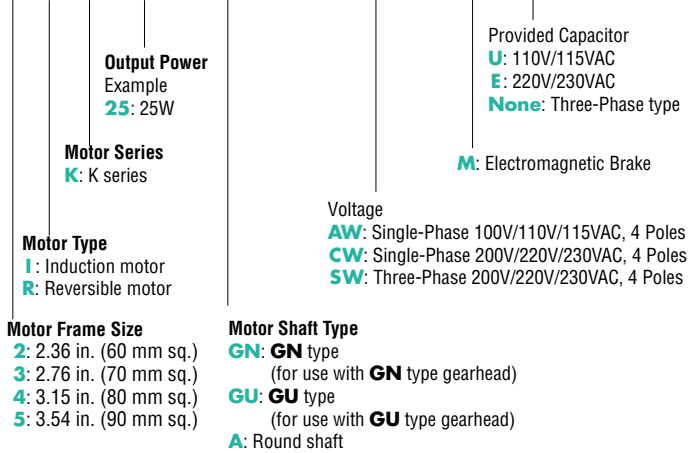

Note : The "U" and "E" at the end of the model number indicate that the unit includes a capacitor. These two letters are not listed on the motor nameplate.

● Gearhead

4 GN 50 KA

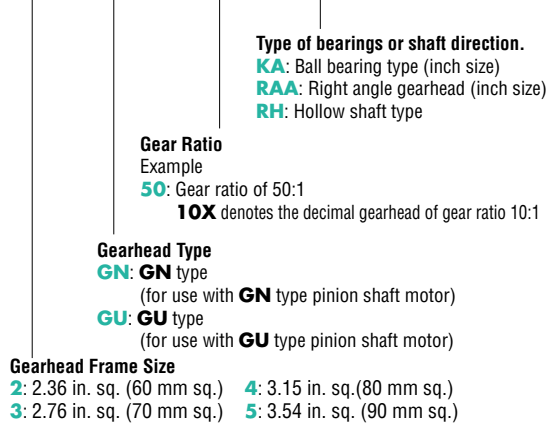

Note :

- The **GU** type includes two types of model number: box-shaped models with a "B" at the end of their model number and models with mounting flanges with nothing at the end of their model number. All other series consist of box-shaped models only and have nothing at the end of their model number.
- See page 56 for data regarding inch size gearheads shafts.

● For -AMUL Type

4RK25GN - A M UL

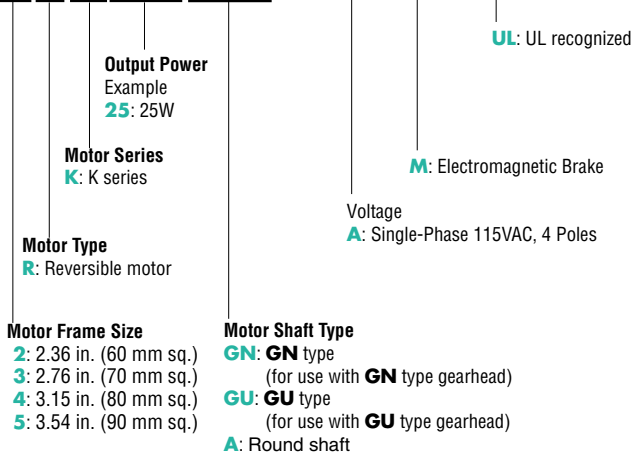

■ Motor Specifications 30 Minute Rating

| Mode | | Output Power | | Voltage | Frequency | Current | Starting Torque | Rated Torque | Rated Speed | Capacitor | | | | | | | | |
|-------------------|------------------|--------------|--------|---------|------------------|---------|-----------------|--------------|-------------|-----------|-------|------|-----|------|------|-----|------|------|
| Pinion Shaft Type | Round Shaft Type | HP | W | VAC | Hz | A | oz-in | mN-m | oz-in | mN-m | r/min | μF | | | | | | |
| Ⓜ | 2RK6GN-AWMU | 2RK6A-AWMU | 1/124 | 6 | Single-Phase 110 | 60 | 0.25 | 6.2 | 45 | 5.7 | 41 | 1450 | 3.5 | | | | | |
| | | | | | Single-Phase 115 | 60 | 0.26 | | | | | | | | | | | |
| Ⓜ | 2RK6GN-CWME | 2RK6A-CWME | 1/124 | 6 | Single-Phase 220 | 60 | 0.11 | 6.2 | 45 | 5.7 | 41 | 1450 | 0.8 | | | | | |
| | | | | | Single-Phase 230 | 50 | 0.12 | | | | | | | 6.9 | 50 | 6.8 | 49 | 1200 |
| | | | | | Single-Phase 230 | 60 | 0.12 | | | | | | | | | | | |
| Ⓜ | 2RK6GN-AMUL | 2RK6A-AMULA | 1/124 | 6 | Single-Phase 115 | 60 | 0.17 | 6.7 | 48 | 5.3 | 38 | 1550 | 2.3 | | | | | |
| Ⓜ | 3RK15GN-AWMU | 3RK15A-AWMU | 1/50 | 15 | Single-Phase 110 | 60 | 0.42 | 13.9 | 100 | 14.6 | 105 | 1450 | 6 | | | | | |
| | | | | | Single-Phase 115 | 60 | 0.41 | | | | | | | | | | | |
| Ⓜ | 3RK15GN-AMUL | 3RK15A-AMULA | 1/50 | 15 | Single-Phase 115 | 60 | 0.34 | 11.1 | 80 | 13.2 | 95 | 1550 | 4.5 | | | | | |
| Ⓜ | 4RK25GN-AWMU | 4RK25A-AWMU | 1/30 | 25 | Single-Phase 110 | 60 | 0.54 | 19.4 | 140 | 23.6 | 170 | 1450 | 8 | | | | | |
| | | | | | Single-Phase 115 | 60 | | | | | | | | | | | | |
| | | | | | Single-Phase 220 | 60 | | | | | | | | 0.28 | 19.4 | 140 | 23.6 | 170 |
| Ⓜ | 4RK25GN-CWME | 4RK25A-CWME | 1/30 | 25 | Single-Phase 230 | 50 | 0.26 | 22.2 | 160 | 28.5 | 205 | 1200 | 2 | | | | | |
| | | | | | Single-Phase 230 | 60 | 0.28 | 19.4 | 140 | 23.6 | 170 | 1450 | | | | | | |
| | | | | | Three-Phase 200 | 50 | 0.23 | 33.3 | 240 | 26.4 | 190 | 1300 | | | | | | |
| Ⓜ | 4IK25GN-SWM | 4IK25A-SWM | 1/30 | 25 | Three-Phase 200 | 60 | 0.21 | 22.2 | 160 | 22.2 | 160 | 1550 | — | | | | | |
| | | | | | Three-Phase 220 | 60 | 0.21 | 22.2 | 160 | 22.2 | 160 | 1600 | | | | | | |
| | | | | | Three-Phase 230 | 60 | 0.22 | 22.2 | 160 | 22.2 | 160 | 1600 | | | | | | |
| | | | | | Three-Phase 230 | 60 | 0.22 | 22.2 | 160 | 22.2 | 160 | 1600 | | | | | | |
| Ⓜ | 4RK25GN-AMUL | 4RK25A-AMULA | 1/30 | 25 | Single-Phase 115 | 60 | 0.54 | 17.4 | 125 | 22.2 | 160 | 1550 | 7 | | | | | |
| Ⓜ | 5RK40GN-AWMU | 5RK40A-AWMU | 1/18.5 | 40 | Single-Phase 110 | 60 | 0.81 | 36.1 | 260 | 37.5 | 270 | 1450 | 12 | | | | | |
| | | | | | Single-Phase 115 | 60 | | | | | | | | | | | | |
| Ⓜ | 5RK40GN-CWME | 5RK40A-CWME | 1/18.5 | 40 | Single-Phase 220 | 60 | 0.46 | 36.1 | 260 | 36.1 | 260 | 1500 | 3.5 | | | | | |
| | | | | | Single-Phase 230 | 50 | 0.4 | 37.5 | 270 | 43.7 | 315 | 1250 | | | | | | |
| | | | | | Single-Phase 230 | 60 | 0.46 | 36.1 | 260 | 36.1 | 260 | 1500 | | | | | | |
| Ⓜ | 5IK40GN-SWM | 5IK40A-SWM | 1/18.5 | 40 | Three-Phase 200 | 50 | 0.32 | 55.5 | 400 | 41.7 | 300 | 1300 | — | | | | | |
| | | | | | Three-Phase 200 | 60 | 0.3 | 36.1 | 260 | 36.1 | 260 | 1550 | | | | | | |
| | | | | | Three-Phase 220 | 60 | 0.3 | 36.1 | 260 | 36.1 | 260 | 1600 | | | | | | |
| | | | | | Three-Phase 230 | 60 | 0.31 | 36.1 | 260 | 36.1 | 260 | 1600 | | | | | | |
| Ⓜ | 5RK40GN-AMUL | 5RK40A-AMULA | 1/18.5 | 40 | Single-Phase 115 | 60 | 0.81 | 34.7 | 250 | 36.1 | 260 | 1550 | 12 | | | | | |
| Ⓜ | 5RK60GU-AWMU | 5RK60A-AWMU | 1/12.5 | 60 | Single-Phase 110 | 60 | 1.24 | 52.8 | 380 | 56.2 | 405 | 1450 | 20 | | | | | |
| | | | | | Single-Phase 115 | 60 | | | | | | | | | | | | |
| Ⓜ | 5RK60GU-CWME | 5RK60A-CWME | 1/12.5 | 60 | Single-Phase 220 | 60 | 0.67 | 52.8 | 380 | 56.2 | 405 | 1450 | 5 | | | | | |
| | | | | | Single-Phase 230 | 50 | 0.61 | 65.3 | 470 | 68 | 490 | 1200 | | | | | | |
| | | | | | Single-Phase 230 | 60 | 0.67 | 52.8 | 380 | 56.2 | 405 | 1450 | | | | | | |
| | | | | | Three-Phase 200 | 60 | 0.5 | 83.3 | 600 | 62.5 | 450 | 1300 | | | | | | |
| Ⓜ | 5IK60GU-SWM | 5IK60A-SWM | 1/12.5 | 60 | Three-Phase 200 | 60 | 0.43 | 69.4 | 500 | 52.8 | 380 | 1550 | — | | | | | |
| | | | | | Three-Phase 220 | 60 | 0.45 | 69.4 | 500 | 52.8 | 380 | 1600 | | | | | | |
| | | | | | Three-Phase 230 | 60 | 0.46 | 69.4 | 500 | 52.8 | 380 | 1600 | | | | | | |
| Ⓜ | 5RK60GU-AMUL | 5RK60A-AMUL | 1/12.5 | 60 | Single-Phase 115 | 60 | 1.2 | 54.2 | 390 | 52.8 | 380 | 1550 | 20 | | | | | |
| Ⓜ | 5RK90GU-AWMU | 5RK90A-AWMU | 1/8 | 90 | Single-Phase 110 | 60 | 1.81 | 81.9 | 590 | 81.2 | 585 | 1500 | 30 | | | | | |
| | | | | | Single-Phase 115 | 60 | | | | | | | | | | | | |
| Ⓜ | 5RK90GU-CWME | 5RK90A-CWME | 1/8 | 90 | Single-Phase 220 | 60 | 0.96 | 81.9 | 590 | 84 | 605 | 1450 | 7 | | | | | |
| | | | | | Single-Phase 230 | 50 | 0.82 | 83.3 | 600 | 101 | 730 | 1200 | | | | | | |
| | | | | | Single-Phase 230 | 60 | 0.96 | 81.9 | 590 | 84 | 605 | 1450 | | | | | | |
| Ⓜ | 5IK90GU-SWM | 5IK90A-SWM | 1/8 | 90 | Three-Phase 200 | 50 | 0.64 | 118 | 850 | 94.4 | 680 | 1300 | — | | | | | |
| | | | | | Three-Phase 200 | 60 | 0.59 | 97.2 | 700 | 79.2 | 570 | 1550 | | | | | | |
| | | | | | Three-Phase 220 | 60 | 0.6 | 97.2 | 700 | 79.2 | 570 | 1600 | | | | | | |
| Ⓜ | 5RK90GU-AMUL | 5RK90A-AMUL | 1/8 | 90 | Single-Phase 115 | 60 | 1.65 | 81.9 | 590 | 79.2 | 570 | 1550 | 25 | | | | | |

Ⓜ: These motors are impedance protected.

Ⓜ: These motors contain a built-in thermal protector. If a motor overheats for any reason, the thermal protector is opened and the motor stops. When the motor temperature drops, the thermal protector closes and the motor restarts. Be sure to turn the motor off before inspecting.

• The "U" and "E" at the end of the model number indicate that the unit includes a capacitor. These two letters are not listed on the motor nameplate.

When the motor is approved under various safety standards, the nameplate is adopted.

• A colored background indicates gear shaft rotation in the same direction as the motor shaft; a white background indicates rotation in the opposite direction.

■ Motor General Specifications For -AWMU, -CWME, -SWM Type

| Item | Specifications |
|----------------------------|--|
| Insulation Resistance | 100M Ω or more when 500V DC is applied between the windings and the frame after rated motor operation under normal ambient temperature and humidity. |
| Dielectric Strength | Sufficient to withstand 1.5kV at 50 and 60 Hz applied between the windings and the frame after rated motor operation under normal ambient temperature and humidity. |
| Temperature Rise | 144°F (80°C) or less measured by the resistance change method after the temperature of 30minute no load operation of motor with connecting a gearhead or equivalent heat radiation plate.* |
| Insulation Class | Class B 266°F (130°C) |
| Overheat Protection Device | 2RK type is impedance protected. Built-in thermal protector (Automatic return type) Open: 266°F±9°F (130°C±5°C) Close: 179.6°F±27°F (82°C±15°C) |
| Ambient Temperature Range | 14°F~104°F (-10°C~+40°C) Three-Phase 200V : 14°F~122°F (-10°C~+50°C) |
| Ambient Humidity | 85% Maximum (noncondensing) |
| Degree of protection | 2RK, 3RK, 4RK, 4IK, 5RK40, 5IK40 type : IP20 5RK60, 5IK60, 5RK90, 5IK90 type : IP40 |

■ Motor General Specifications For -AMUL Type

| Item | Specification |
|----------------------------|---|
| Insulation Resistance | 100M Ω or more when 500V DC is applied between the windings and the frame after rated motor operation under normal ambient temperature and humidity. |
| Dielectric Strength | Sufficient to withstand 1.5kV at 50Hz and 60Hz applied between the windings and the frame after rated motor operation under normal ambient temperature and humidity. |
| Temperature Rise | 135°F (75°C) or less measured by the resistance change method after the temperature of the coil has stabilized under normal operation at the rated voltage and frequency. |
| Insulation Class | UL · CSA Standard Class A, EN60950 Standard Class E |
| Overheat Protection Device | 2RK type is impedance protected. Built-in thermal protector (Automatic return type) Open: 248°F±9°F (120°C±5°C) Close: 170.6°F±27°F (77°C±15°C) |
| Ambient Temperature Range | 14°F~104°F (-10°C~+40°C) |
| Ambient Humidity | 85% Maximum (noncondensing) |

● Equivalent heat radiation plate (material : Aluminum)

| Type (output) | Size inch (mm) | Thickness inch (mm) |
|--------------------------------|---------------------|---------------------|
| 2RK Type (6W) | 4.53×4.53 (115×115) | 0.20 (5) |
| 3RK Type (15W) | 4.92×4.92 (125×125) | |
| 4IK, 4RK Type (25W) | 5.31×5.31 (135×135) | |
| 5IK40, 5RK40 Type (40W) | 6.50×6.50 (165×165) | |
| 5IK60, 5RK60 Type (60W) | 7.87×7.87 (200×200) | |
| 5IK90, 5RK90 Type (90W) | 7.87×7.87 (200×200) | |

■ Electromagnetic Brake Specifications

| Model | Voltage VAC | Frequency | Current | Input Holding Brake Torque | |
|---------------------|------------------|-----------|---------|----------------------------|------------|
| | | Hz | A | W | oz-in mN·m |
| 2RK6GN-AWMU | Single-Phase 110 | 60 | 0.03 | 3 | 4.2 30 |
| 2RK6A-AWMU | Single-Phase 115 | 60 | 0.03 | 3 | 4.2 30 |
| 2RK6GN-CWME | Single-Phase 220 | 60 | 0.02 | 3 | 4.2 30 |
| 2RK6A-CWME | Single-Phase 230 | 50 | 0.02 | 3 | 4.2 30 |
| | Single-Phase 230 | 60 | 0.02 | 3 | 4.2 30 |
| 2RK6GN-AMUL | Single-Phase 115 | 60 | 0.032 | 2.3 | 4.2 30 |
| 2RK6A-AMULA | Single-Phase 115 | 60 | 0.032 | 2.3 | 4.2 30 |
| 3RK15GN-AWMU | Single-Phase 110 | 60 | 0.06 | 4 | 11.1 80 |
| 3RK15A-AWMU | Single-Phase 115 | 60 | 0.06 | 4 | 11.1 80 |
| 3RK15GN-AMUL | Single-Phase 115 | 60 | 0.046 | 4.2 | 11.1 80 |
| 3RK15A-AMULA | Single-Phase 115 | 60 | 0.046 | 4.2 | 11.1 80 |
| 4RK25GN-AWMU | Single-Phase 110 | 60 | 0.08 | 5 | 13.9 100 |
| 4RK25A-AWMU | Single-Phase 115 | 60 | | 6 | 13.9 100 |
| 4RK25GN-CWME | Single-Phase 220 | 60 | 0.04 | 6 | 13.9 100 |
| 4RK25A-CWME | Single-Phase 230 | 50 | 0.05 | 7 | 13.9 100 |
| | Single-Phase 230 | 60 | 0.05 | 6 | 13.9 100 |
| | Single-Phase 200 | 50 | 0.04 | 5 | 13.9 100 |
| 4IK25GN-SWM | Single-Phase 200 | 60 | 0.04 | 5 | 13.9 100 |
| 4IK25A-SWM | Single-Phase 220 | 60 | 0.04 | 6 | 13.9 100 |
| | Single-Phase 230 | 60 | 0.04 | 6 | 13.9 100 |
| 4RK25GN-AMUL | Single-Phase 115 | 60 | 0.055 | 5.2 | 13.9 100 |
| 4RK25A-AMULA | Single-Phase 115 | 60 | 0.055 | 5.2 | 13.9 100 |
| 5RK40GN-AWMU | Single-Phase 110 | 60 | 0.08 | 6 | 27.8 200 |
| 5RK40A-AWMU | Single-Phase 115 | 60 | 0.09 | 7 | 27.8 200 |
| | Single-Phase 220 | 60 | 0.04 | 6 | 27.8 200 |
| 5RK40GN-CWME | Single-Phase 230 | 50 | 0.04 | 6 | 27.8 200 |
| 5RK40A-CWME | Single-Phase 230 | 60 | 0.04 | 6 | 27.8 200 |

| Model | Voltage VAC | Frequency | Current | Input Holding Brake Torque | |
|---------------------|------------------|-----------|---------|----------------------------|------------|
| | | Hz | A | W | oz-in mN·m |
| 5IK40GN-SWM | Single-Phase 200 | 50 | 0.04 | 5 | 27.8 200 |
| 5IK40A-SWM | Single-Phase 220 | 60 | 0.04 | 5 | 27.8 200 |
| | Single-Phase 220 | 60 | 0.04 | 6 | 27.8 200 |
| | Single-Phase 230 | 60 | 0.04 | 6 | 27.8 200 |
| 5RK40GU-AMUL | Single-Phase 115 | 60 | 0.053 | 5.7 | 27.7 200 |
| 5RK40A-AMULA | Single-Phase 115 | 60 | 0.053 | 5.7 | 27.7 200 |
| 5RK60GU-AWMU | Single-Phase 110 | 60 | 0.12 | 9 | 69.4 500 |
| 5RK60A-AWMU | Single-Phase 115 | 60 | 0.12 | 9 | 69.4 500 |
| 5RK60GU-CWME | Single-Phase 220 | 60 | 0.06 | 8 | 69.4 500 |
| 5RK60A-CWME | Single-Phase 230 | 50 | 0.06 | 9 | 69.4 500 |
| | Single-Phase 230 | 60 | 0.06 | 9 | 69.4 500 |
| | Single-Phase 200 | 50 | 0.05 | 7 | 69.4 500 |
| 5IK60GU-SWM | Single-Phase 200 | 60 | 0.05 | 7 | 69.4 500 |
| 5IK60A-SWM | Single-Phase 220 | 60 | 0.06 | 8 | 69.4 500 |
| | Single-Phase 230 | 60 | 0.06 | 9 | 69.4 500 |
| 5RK60GU-AMUL | Single-Phase 115 | 60 | 0.064 | 6.7 | 69.4 500 |
| 5RK60A-AMULA | Single-Phase 115 | 60 | 0.064 | 6.7 | 69.4 500 |
| 5RK90GU-AWMU | Single-Phase 110 | 60 | 0.12 | 9 | 69.4 500 |
| 5RK90A-AWMU | Single-Phase 115 | 60 | 0.12 | 9 | 69.4 500 |
| 5RK90GU-CWME | Single-Phase 220 | 60 | 0.06 | 8 | 69.4 500 |
| 5RK90A-CWME | Single-Phase 230 | 50 | 0.06 | 9 | 69.4 500 |
| | Single-Phase 230 | 60 | 0.06 | 9 | 69.4 500 |
| | Single-Phase 200 | 50 | 0.05 | 7 | 69.4 500 |
| 5IK90GU-SWM | Single-Phase 200 | 60 | 0.05 | 7 | 69.4 500 |
| 5IK90A-SWM | Single-Phase 220 | 60 | 0.06 | 8 | 69.4 500 |
| | Single-Phase 230 | 60 | 0.06 | 9 | 69.4 500 |
| 5RK90GU-AMUL | Single-Phase 115 | 60 | 0.064 | 6.7 | 69.4 500 |
| 5RK90A-AMUL | Single-Phase 115 | 60 | 0.064 | 6.7 | 69.4 500 |

■ Wiring Diagrams

2RK6GN-AWMU
2RK6GN-CWME
3RK15GN-AWUMU
4RK25GN-AWUMU
4RK25GN-CWME
5RK40GN-AWUMU
5RK40GN-CWME
5RK60GU-AWUMU
5RK60GU-CWME
5RK90GU-AWUMU
5RK90GU-CWME

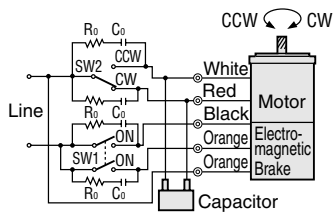

| SW No. | Specifications of Switches | | Note |
|--------------------------|--|--|----------------------------------|
| | Single-Phase 110VAC Single-Phase 115VAC | Single-Phase 220VAC Single-Phase 230VAC | |
| SW1 | 125VAC 3A Min | 250VAC 1.5A Min | Single-pole-double-throw switch |
| SW2 | Inductive | Inductive | |
| Ro, Co Surge absorber | Ro=5~200Ω Co=0.1~0.2μF 200WV | | Accessories EPCR1201-2 |

Run/Stop: SW1 operates motor and electromagnetic brake action. Motor will rotate when SW1 is switched to ON (short circuit).

When SW1 is switched to OFF (open), the motor is stopped immediately by the electromagnetic brake and holds the load.

If you wish to release the brake while the motor is stopped, apply voltage between only two brake lead wires (orange). The electromagnetic brake is released and the motor shaft can be rotated easily by hand.

Direction of Rotation: To rotate the motor in a clockwise (CW) direction, switch SW2 to CW. To rotate it in a counterclockwise (CCW) direction, switch SW2 to CCW.

Direction of motor rotation are shown when the motor is viewed from the shaft end of the motor.

4IK25GN-SWM
5IK40GN-SWM
5IK60GU-SWM
5IK90GU-SWM

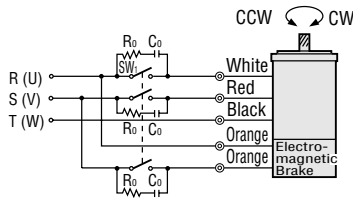

| SW No. | Specifications of Switch | Note |
|--------------------------|------------------------------------|----------------------------------|
| SW1 | 250VAC 5A Min Inductive | Single-pole-double-throw switch |
| Ro, Co Surge absorber | Ro=5~200Ω Co=0.1~0.2μF 200WV | Accessories EPCR1201-2 |

Run/Stop: SW1 operates motor and electromagnetic brake action. Motor will rotate when SW1 is switched to ON (short circuit).

When SW1 is switched to OFF (open), the motor is stopped immediately by the electromagnetic brake and holds the load.

If you wish to release the brake while the motor is stopped, apply voltage between only two brake lead wires (orange). The electromagnetic brake is released and the motor shaft can be rotated easily by hand.

Direction of Rotation: To change the rotation, change any two connections between U, V and W.

2RK6GN-AMUL
2RK6A-AMULA
3RK15GN-AMUL
3RK15A-AMULA
4RK25GN-AMUL
4RK25A-AMULA
5RK40GN-AMUL
5RK40A-AMULA

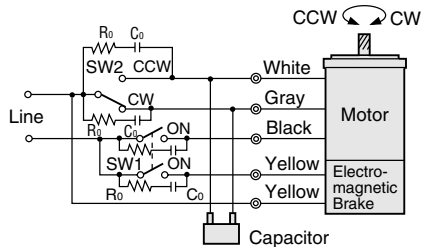

Run/Stop

SW1 operates motor and electromagnetic brake action. Motor will rotate when SW1 is switched to ON (short circuit).

When SW1 is switched to OFF (open), the motor is stopped immediately by the electromagnetic brake and holds the load.

If you wish to release the brake while the motor is stopped, apply voltage between only two brake lead wires (orange or yellow). The electromagnetic brake is released and the motor shaft can be rotated easily by hand.

Direction of Rotation
To rotate the motor in a clockwise (CW) direction, switch SW2 to CW. To rotate it in a counterclockwise (CCW) direction, switch SW2 to CCW.

Direction of Rotation

To rotate the motor in a clockwise (CW) direction, switch SW2 to CW. To rotate it in a counterclockwise (CCW) direction, switch SW2 to CCW.

Directions of motor rotation are shown when the motor is viewed from the shaft end of the motor.

| SW No. | Specifications of Switch | Note |
|--------------------------|---|----------------------------------|
| SW1 | 125VAC 3A Min (6W~40W) 125VAC 5A Min (60W, 90W) Inductive | Single-pole-double-throw switch |
| Ro, Co Surge absorber | Ro=5~200Ω Co=0.1~0.2μF 200WV | Accessories EPCR1201-2 |

5RK60GU-AMUL
5RK60A-AMUL
5RK90GU-AMUL
5RK90A-AMUL

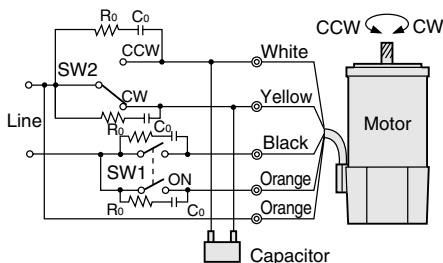

■ Variation in braking time according to connection

Connection can be simplified by using the wiring diagram shown in figure ②, rather than the normal wiring shown in figure ①.

Using the connection shown in figure ②, however, results in a 50 msec. increase in braking time over that shown in figure ①, with a corresponding increase in overrun.

The reason for this is that the electromagnetic energy of the motor continues to have an effect on the coil of the electromagnetic brake, so that the electromagnet continues to operate for 50 msec. even though the excitation has been canceled. The brake therefore takes longer to engage.

① Normal Connection

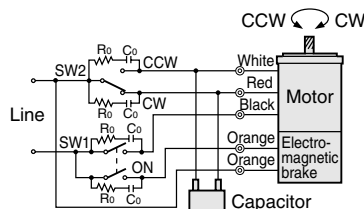

② Simplified Connection

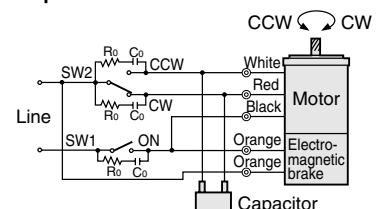

Starting and Braking Characteristics

As an example, we have calculated the motor starting time, braking time and overrun when driving an inertial load ($J_L = 1375$ oz-in²) for the motor **4RK25GN-AMUL** when combined with the gearhead **4GN30KA**.

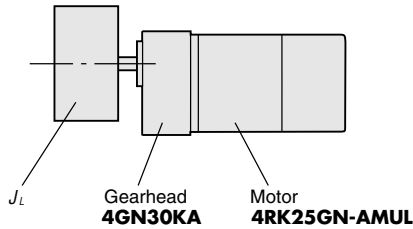

First, convert load inertia to its corresponding value at the motor shaft.

$$J_M = \frac{J_L}{i^2} = \frac{1375}{30^2} \approx 1.5 \text{ [oz-in}^2\text{]}$$

J_L : Inertia of the load [oz-in²]

J_M : Inertia at motor shaft [oz-in²]

i : Gear ratio

2RK6GN-AWMU / 2RK6GN-CWME

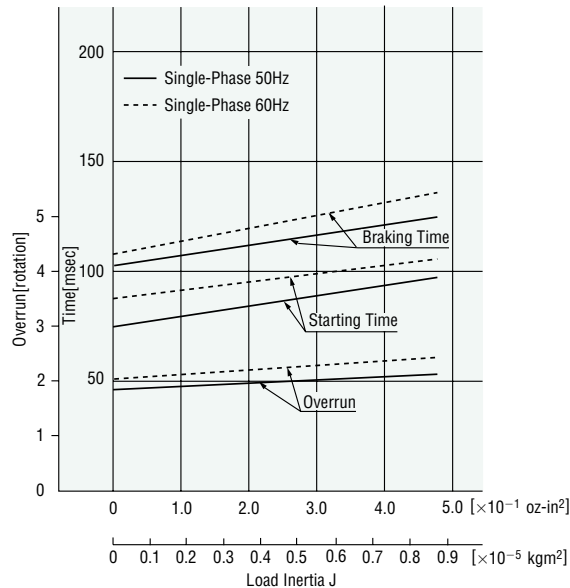

4RK25GN-AWMU / 4RK25GN-CWME

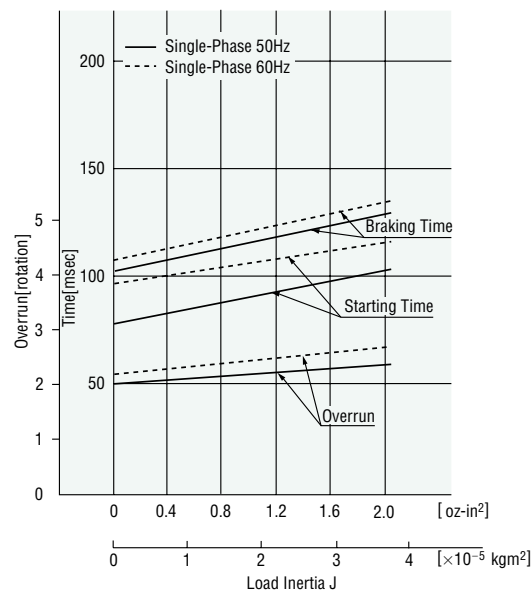

Overrun

The overrun of the motor shaft based on the graph on the next page is:

$$N_M \approx 2.6 \text{ revolutions}$$

Overrun of gearhead output shaft is:

$$N_G = \frac{N_M}{i} = \frac{2.6}{30} = 0.09 \text{ revolutions (32}^\circ\text{)}$$

Starting time and braking time

Using the graph again gives:

Starting time $t_1 \approx 110$ msec

Braking time $t_2 \approx 130$ msec

The starting time of an electromagnetic brake motor is equal to the motor starting time plus the electromagnetic brake release time. If the electromagnetic brake is left released, the motor can be started much faster. Optimum time for release of the brake is at least 10 msec. before starting up the motor.

3RK15GN-AWMU / 3RK15GN-AMUL

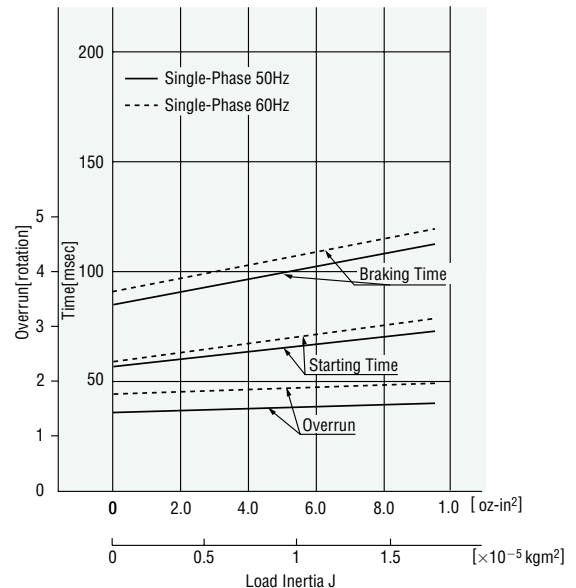

4IK25GN-SWM

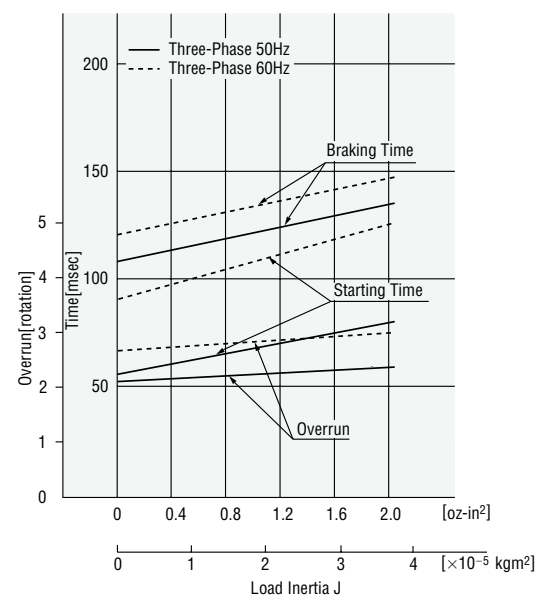

5RK40GN-AWMU / 5RK40GN-CWME
5RK40GN-AMUL

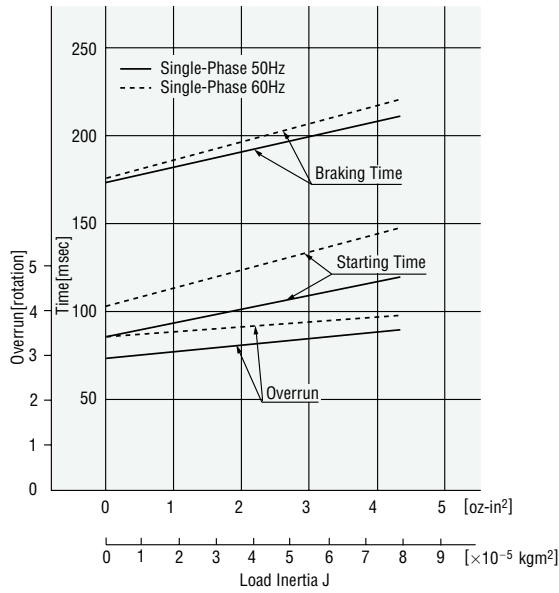

5IK40GN-SWM

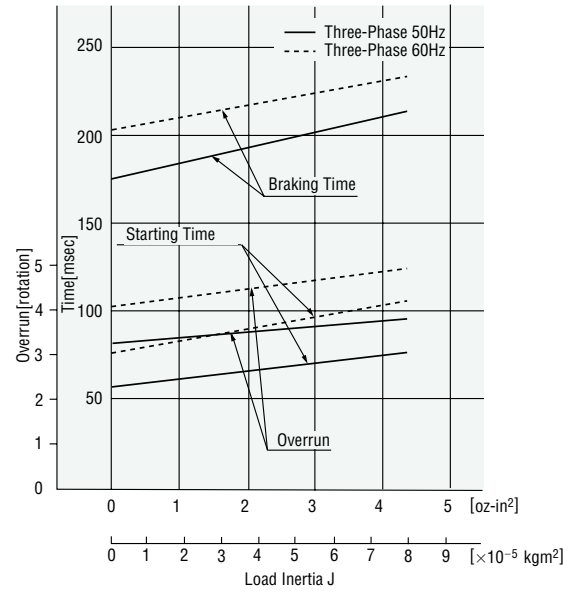

5RK60GU-AWMU / 5RK60GU-CWME
5RK60GU-AMUL

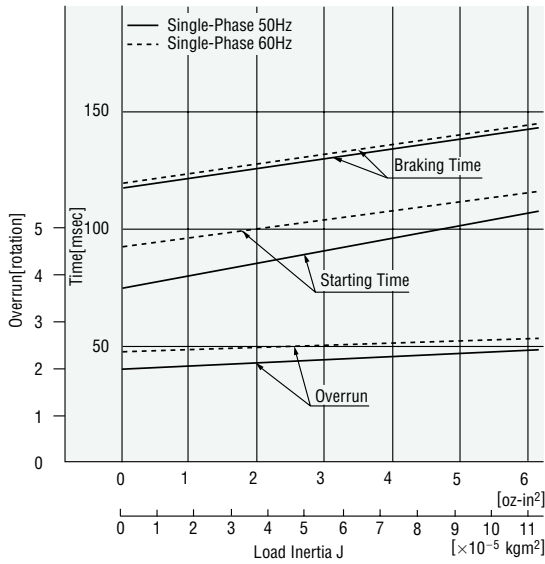

5IK60GU-SWM

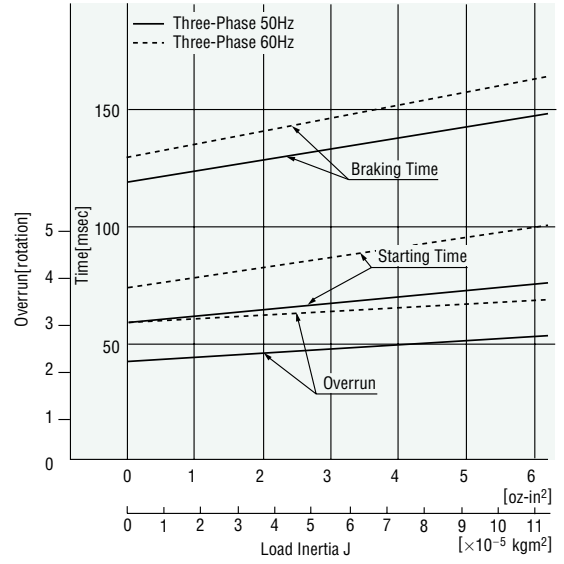

5RK90GU-AWMU / 5RK90GU-CWME
5RK90GU-AMUL

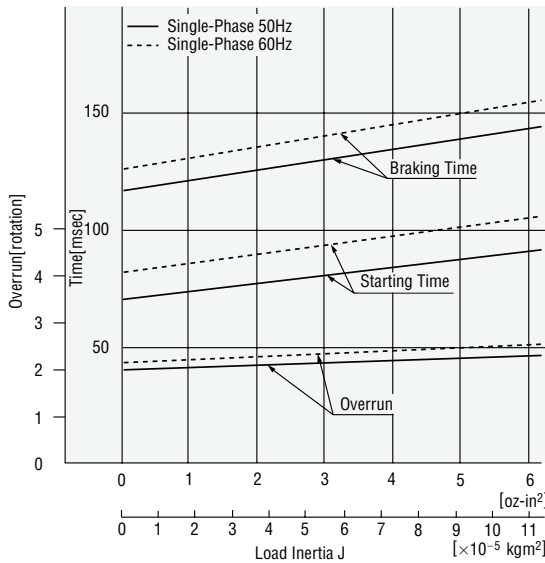

5IK90GU-SWM

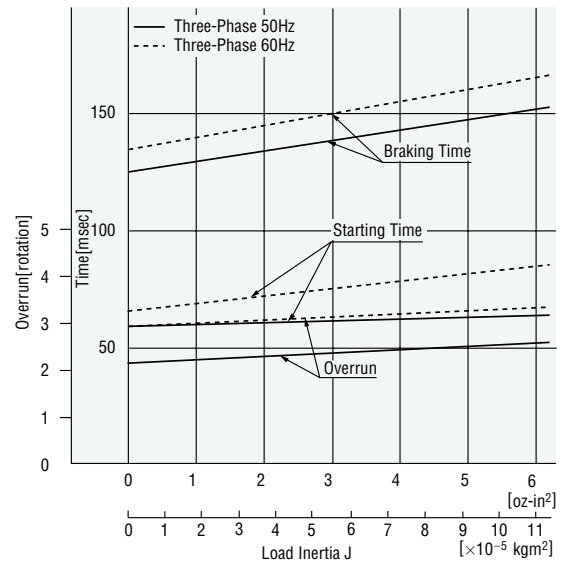

■ Dimensions Scale 1/4, Unit = inch (mm)

● Motor

2RK6GN-AWMU Weight (Mass): 2.0 lb. (0.9 kg)
2RK6GN-CWME Weight (Mass): 2.0 lb. (0.9 kg)
2RK6GN-AMUL Weight (Mass): 2.0 lb. (0.9 kg)

Gearhead

2GN□KA
 Weight (Mass): 0.88 lb. (0.4 kg)

● Round Shaft Type

2RK6A-AWMU Weight (Mass): 2.0 lb. (0.9 kg)
2RK6A-CWME Weight (Mass): 2.0 lb. (0.9 kg)
2RK6A-AMULA Weight (Mass): 2.0 lb. (0.9 kg)

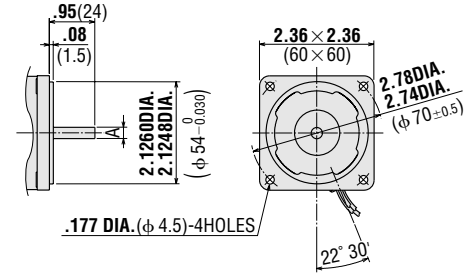
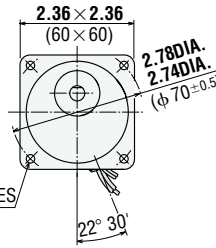
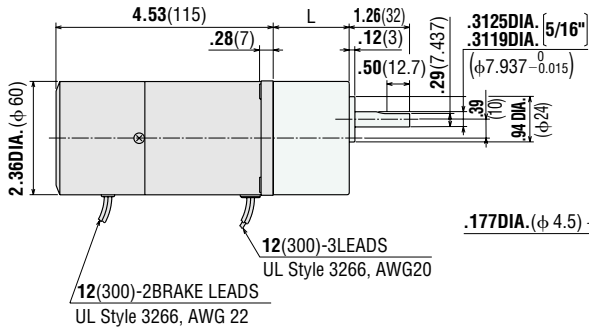

Unit = inch (mm)

| Model | A |
|--------------------|---|
| 2RK6A-AWME | .2362DIA. (φ 6 ⁰ _{-0.012}) |
| 2RK6A-CWME | .2357DIA. (φ 6 ⁰ _{-0.012}) |
| 2RK6A-AMULA | .2500DIA. [1/4"] (φ 6.35 ⁰ _{-0.010}) |
| | .2496DIA. (φ 6.35 ⁰ _{-0.010}) |

L = 1.18 (30) **2GN3KA~18KA**
 L = 1.57 (40) **2GN25KA~180KA**

● Motor

3RK15GN-AWMU Weight (Mass): 2.9 lb. (1.3 kg)
3RK15GN-AMUL Weight (Mass): 2.9 lb. (1.3 kg)

Gearhead

3GN□KA
 Weight (Mass): 1.21 lb. (0.55 kg)

● Round Shaft Type

3RK15A-AWMU Weight (Mass): 2.9 lb. (1.3 kg)
3RK15A-AMULA Weight (Mass): 2.9 lb. (1.3 kg)

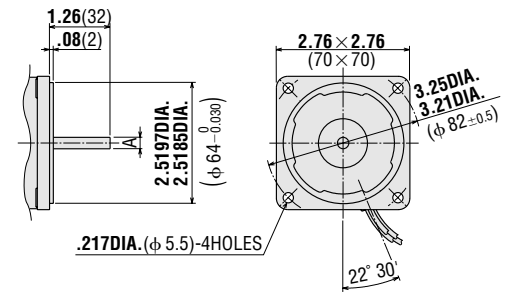
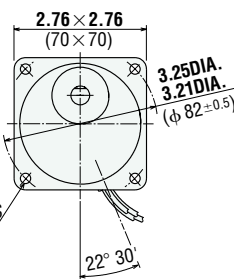
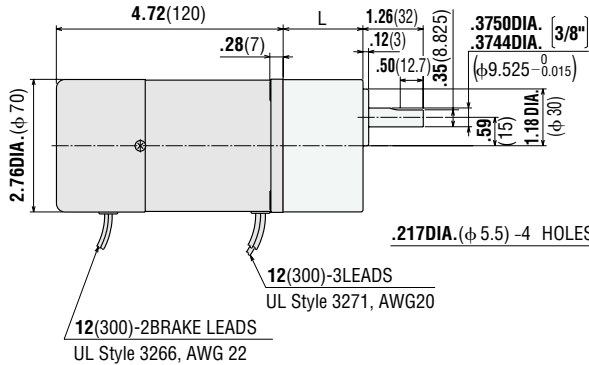

Unit = inch (mm)

| Model | A |
|---------------------|---|
| 3RK15A-AWMU | .2362DIA. (φ 6 ⁰ _{-0.012}) |
| 3RK15A-CWME | .2357DIA. (φ 6 ⁰ _{-0.012}) |
| 3RK15A-AMULA | .2500DIA. [1/4"] (φ 6.35 ⁰ _{-0.010}) |
| | .2496DIA. (φ 6.35 ⁰ _{-0.010}) |

L = 1.26 (32) **3GN3KA~18KA**
 L = 1.65 (42) **3GN25KA~180KA**

● Decimal Gearheads

2GN10XK

Weight (Mass): 0.44 lb. (0.2 kg)

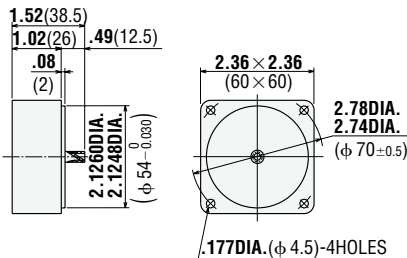

3GN10XK

Weight (Mass): 0.66 lb. (0.3 kg)

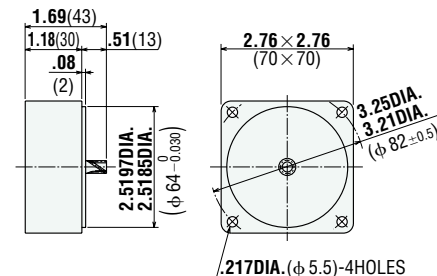

● Motor

- 4RK25GN-AWMU** Weight (Mass): 4.4 lb. (2.0 kg)
- 4RK25GN-CWME** Weight (Mass): 4.4 lb. (2.0 kg)
- 4IK25GN-SWM** Weight (Mass): 4.4 lb. (2.0 kg)
- 4RK25GN-AMUL** Weight (Mass): 4.2 lb. (1.9 kg)

Gearhead

- 4GN□KA** Weight (Mass): 1.43 lb.(0.65 kg)

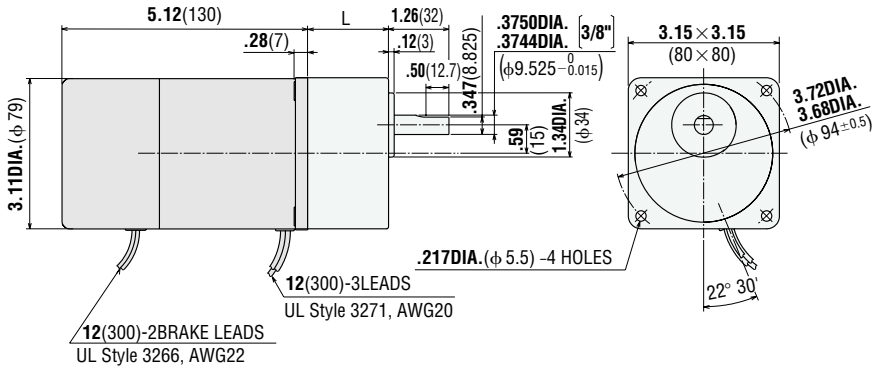

- L = 1.26 (32) **4GN3KA~18KA**
- L = 1.67 (42.5) **4GN25KA~180KA**

● Decimal Gearheads

4GN10XK

Weight (Mass): 0.88 lb. (0.4 kg)

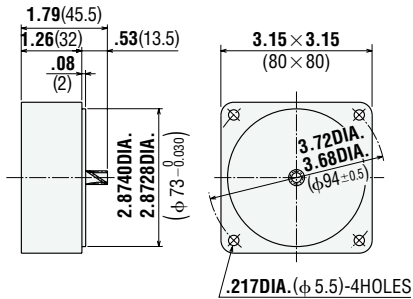

● Round Shaft Type

- 4RK25A-AWMU** Weight (Mass): 4.4 lb. (2.0 kg)
- 4RK25A-CWME** Weight (Mass): 4.4 lb. (2.0 kg)
- 4IK25A-SWM** Weight (Mass): 4.4 lb. (2.0 kg)
- 4RK25A-AMULA** Weight (Mass): 4.2 lb. (1.9 kg)

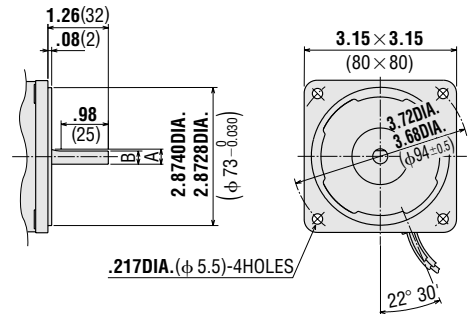

Unit = inch (mm)

| Model | A | B |
|---------------------|------------------------------------|-------------|
| 4RK25A-AWME | .3150DIA. (φ 8 -0.015) | .28 (7) |
| 4RK25A-CWME | .3144DIA. | |
| 4RK25A-SWM | | |
| 4RK25A-AMULA | .3125DIA. [5/16"] (φ 7.937 -0.011) | .28 (7.037) |
| | .3120DIA. | |

● Motor

- 5RK40GN-AWMU** Weight (Mass): 6.4 lb. (2.9 kg)
- 5RK40GN-CWME** Weight (Mass): 6.4 lb. (2.9 kg)
- 5IK40GN-SWM** Weight (Mass): 6.4 lb. (2.9 kg)
- 5RK40GN-AMUL** Weight (Mass): 6.4 lb. (2.9 kg)

Gearhead

- 5GN□KA**
- Weight (Mass): 3.3 lb. (1.5 kg)

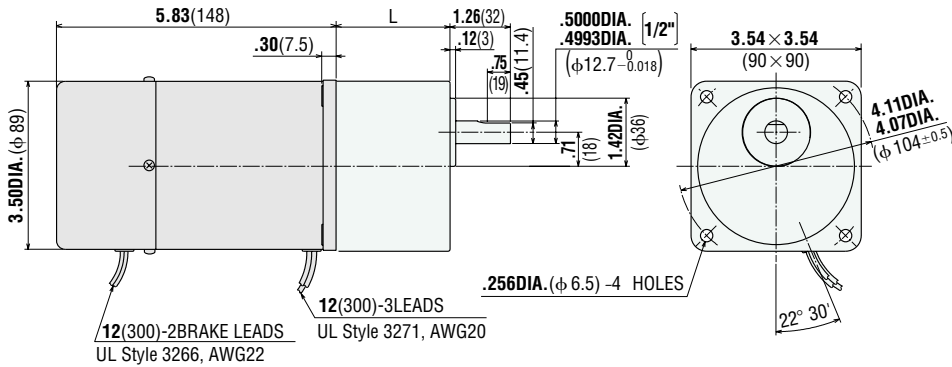

- L = 1.65 (42) **5GN3KA~18KA**
- L = 2.36 (60) **5GN25KA~180KA**

5GN10XK

Weight (Mass): 1.32 lb. (0.6 kg)

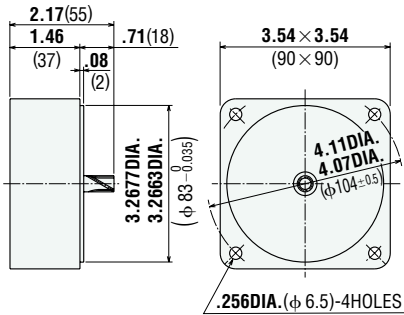

● Round Shaft Type

- 5RK40A-AWMU** Weight (Mass): 6.4 lb. (2.9 kg)
- 5RK40A-CWME** Weight (Mass): 6.4 lb. (2.9 kg)
- 5IK40A-SWM** Weight (Mass): 6.4 lb. (2.9 kg)
- 5RK40A-AMULA** Weight (Mass): 6.4 lb. (2.9 kg)

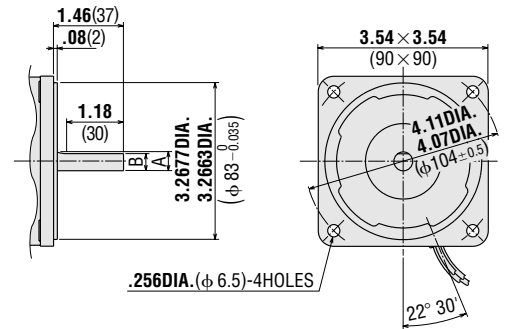

Unit = inch (mm)

| Model | A | B |
|---------------------|-----------------------------|-------------|
| 5RK40A-AWME | .3937DIA. (φ 10 - 0.011) | .35 (9) |
| 5RK40A-CWME | .3933DIA. (φ 10 - 0.011) | .35 (9) |
| 5IK40A-SWM | .3750DIA. (φ 9.525 - 0.011) | .35 (8.825) |
| 5RK40A-AMULA | .3746DIA. (φ 9.525 - 0.011) | .35 (8.825) |

● Motor

5RK60GU-AWMU Weight (Mass): 7.5 lb. (3.4 kg)
5RK60GU-CWME Weight (Mass): 7.5 lb. (3.4 kg)
5IK60GU-SWM Weight (Mass): 7.5 lb. (3.4 kg)
5RK60GU-AMUL Weight (Mass): 7.5 lb. (3.4 kg)

Gearhead

5GU□KA
 Weight (Mass): 3.3 lb. (1.5 kg)

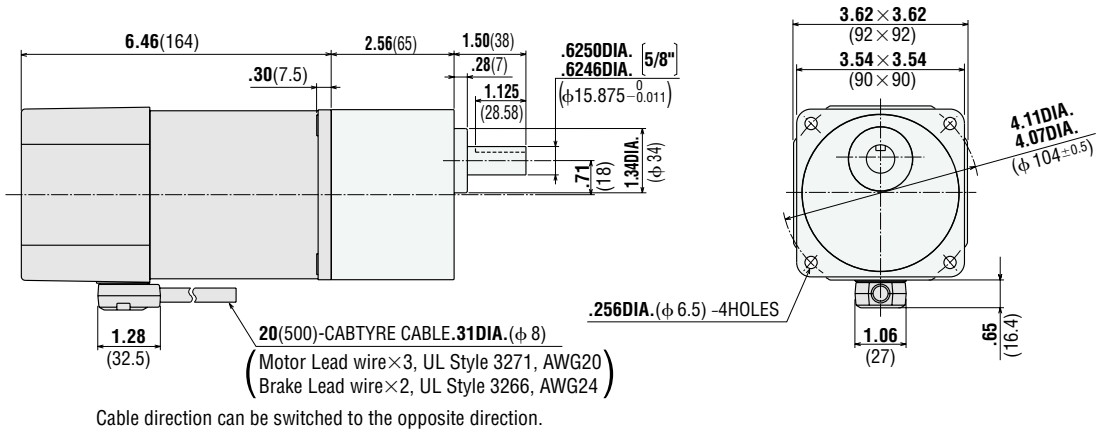

● Key and Key Slot

The key is provided with the gearhead.

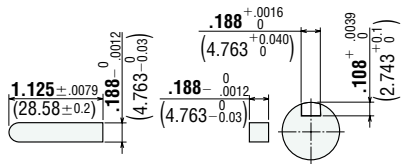

● Round Shaft Type

5RK60A-AWMU Weight (Mass): 7.5 lb. (3.4 kg)
5RK60A-CWME Weight (Mass): 7.5 lb. (3.4 kg)
5IK60A-SWM Weight (Mass): 7.5 lb. (3.4 kg)
5RK60A-AMUL Weight (Mass): 7.5 lb. (3.4 kg)

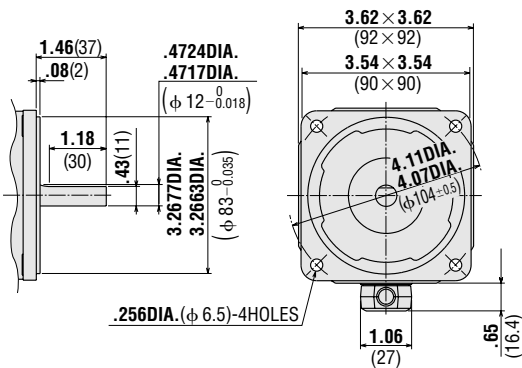

● Decimal Gearheads

5GU10XKB

Weight (Mass): 1.32 lb. (0.6 kg)

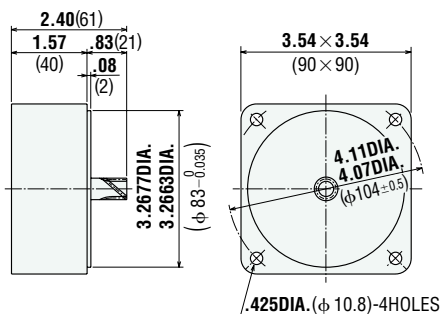

● Motor

5RK90GU-AWMU Weight (Mass): 8.6 lb. (3.9 kg)
5RK90GU-CWME Weight (Mass): 8.6 lb. (3.9 kg)
5IK90GU-SWM Weight (Mass): 8.6 lb. (3.9 kg)
5RK90GU-AMUL Weight (Mass): 8.6 lb. (3.9 kg)

Gearhead

5GU□KA
 Weight (Mass): 3.3 lb. (1.5 kg)

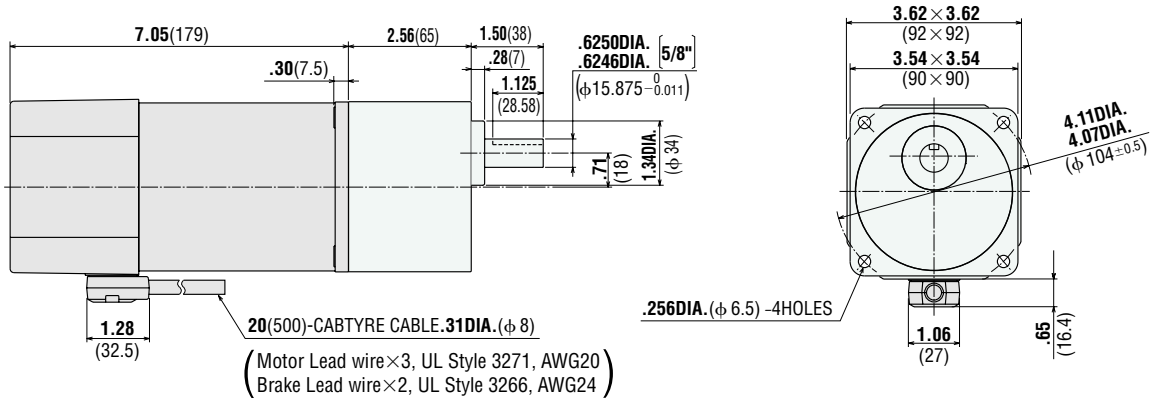

Cable direction can be switched to the opposite direction.

● Key and Key Slot

(provided with the gearhead.)

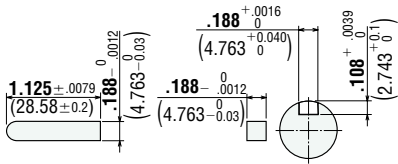

● Round Shaft Type

5RK90A-AWMU Weight (Mass): 8.6 lb.(3.9 kg)
5RK90A-CWME Weight (Mass): 8.6 lb.(3.9 kg)
5IK90A-SWM Weight (Mass): 8.6 lb.(3.9 kg)
5RK90A-AMUL Weight (Mass): 8.6 lb.(3.9 kg)

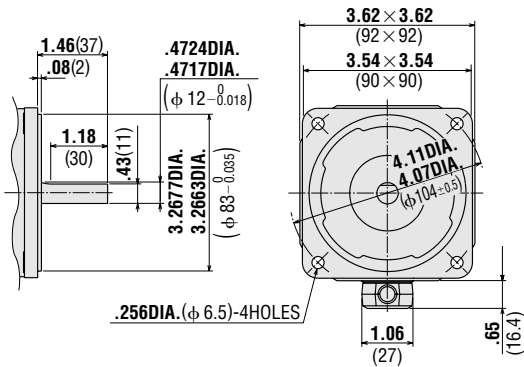

● Decimal Gearheads

5GU10XKB

Weight (Mass): 1.32 lb. (0.6 kg)

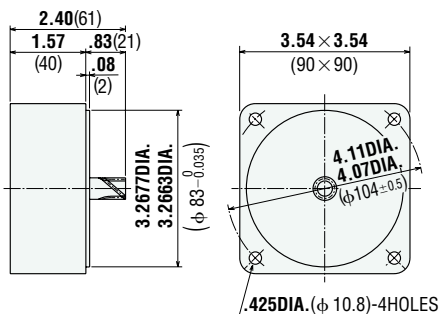

● **Capacitor** (included with the motor)

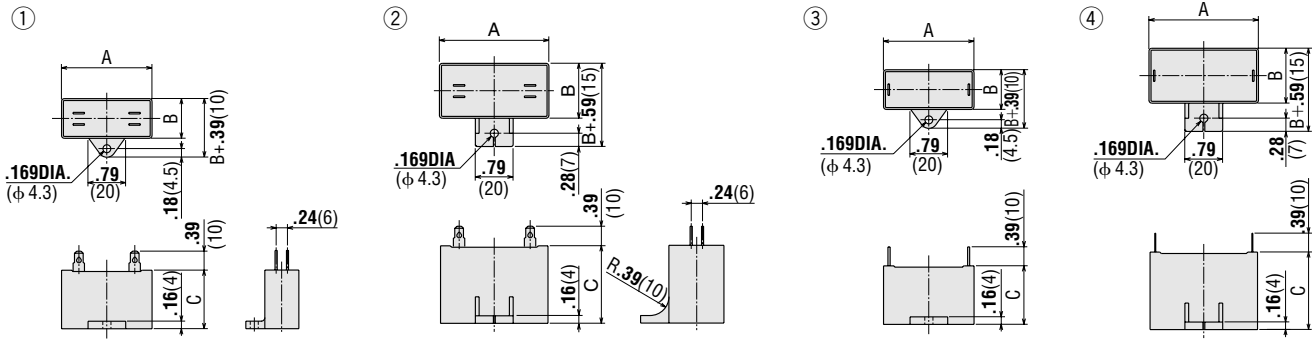

| Motor Model | | Capacitor | Dimensions inch (mm) | | | Weight | | No. |
|----------------------|---------------------|------------|----------------------|------------|------------|--------|-----|-----|
| Pinion Shaft Type | Round Shaft Type | Model | A | B | C | oz. | (g) | |
| 2RK6GN-AWUMU | 2RK6A-AWUMU | CH35FAUL | 1.22 (31) | .67 (17) | 1.06 (27) | 0.88 | 25 | ① |
| 2RK6GN-CWME | 2RK6A-CWME | CH08BFAUL | 1.22 (31) | .67 (17) | 1.06 (27) | 0.88 | 25 | ① |
| 2RK6GN-AMUL | 2RK6A-AMULA | CH23UL | 1.22 (31) | .57 (14.5) | .93 (23.5) | 0.63 | 18 | ③ |
| 3RK15GN-AWUMU | 3RK15A-AWUMU | CH60CFAUL | 1.50 (38) | .83 (21) | 1.22 (31) | 1.4 | 40 | ① |
| 3RK15GN-AMUL | 3RK15A-AMULA | CH45UL | 1.46 (37) | .71 (18) | 1.06 (27) | 0.99 | 28 | ③ |
| 4RK25GN-AWUMU | 4RK25A-AWUMU | CH80CFAUL | 1.89 (48) | .75 (19) | 1.14 (29) | 1.4 | 40 | ① |
| 4RK25GN-CWME | 4RK25A-CWME | CH20BFAUL | 1.89 (48) | .75 (19) | 1.14 (29) | 1 | 35 | ① |
| 4RK25GN-AMUL | 4RK25A-AMULA | CH70UL | 1.50 (38) | .83 (21) | 1.22 (31) | 1.3 | 37 | ③ |
| 5RK40GN-AWUMU | 5RK40A-AWUMU | CH120CFAUL | 2.28 (58) | .83 (21) | 1.22 (31) | 1.8 | 50 | ① |
| 5RK40GN-CWME | 5RK40A-CWME | CH35BFAUL | 2.28 (58) | .87 (22) | 1.38 (35) | 1.9 | 55 | ① |
| 5RK40GN-AMUL | 5RK40A-AMULA | CH120UL | 1.89 (48) | .83 (21) | 1.22 (31) | 1.6 | 45 | ③ |
| 5RK60GU-AWUMU | 5RK60A-AWUMU | CH200CFAUL | 2.28 (58) | 1.14 (29) | 1.61 (41) | 3.4 | 95 | ② |
| 5RK60GU-CWME | 5RK60A-CWME | CH50BFAUL | 2.28 (58) | 1.14 (29) | 1.61 (41) | 3.0 | 85 | ② |
| 5RK60GU-AMUL | 5RK60A-AMULA | CH200UL | 2.28 (58) | .93 (23.5) | 1.46 (37) | 2.3 | 65 | ④ |
| 5RK90GU-AWUMU | 5RK90A-AWUMU | CH300CFAUL | 2.28 (58) | 1.38 (35) | 1.97 (50) | 4.9 | 140 | ② |
| 5RK90GU-CWME | 5RK90A-CWME | CH70BFAUL | 2.28 (58) | 1.38 (35) | 1.97 (50) | 4.6 | 130 | ② |
| 5RK90GU-AMUL | 5RK90A-AMUL | CH250UL | 2.28 (58) | 1.14 (29) | 1.61 (41) | 3.2 | 90 | ④ |

■ **Right-Angle Gearheads (Sold Separately)**

The right-angle gearhead provides an output shaft that is at a right angle to the motor's output shaft. See page [A-216] for specifications and other information.

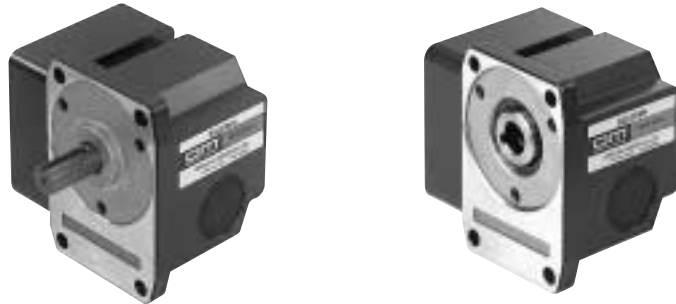

■ **Accessories (Sold Separately)**

● **Motor Mounting Brackets**

Optional die-cast aluminum mounting brackets are available. They can be used to install motors without gearheads. See page[A-266] for the dimensions.



● **Flexible Coupling**

Optional clamp-type couplings are available. See page[A-260] for dimensions.



Clutch and Brake Motors

C·B Motors

This compact precision motor is equipped with an internal clutch and brake for use with a gearhead. The combination makes it the ideal motor for uses involving frequent START/STOP operation, positioning, indexing, jogging and incremental feeding.



Gearhead shown in the photograph is sold separately.



Product Number Code

CB I 5 40 - 7 0 1W U

U: With capacitor for 110V/115V

1W: Single-Phase 110V/115 V

Clutch Brake Type
O: Excitation type

Motor Shaft Type
7: GC- type pinion shaft
8: GCH- type pinion shaft

Output Power
40: 40W
60: 60W
90: 90W

Motor Frame Size
5: 3.54 in.sq. (90mm sq.)

Motor Type
I: Induction motor

Series: Clutch and Brake Motor

Note : The "U" at the end of the part number indicate that the unit includes a capacitor. This letter is not listed on the motor nameplate.

Features

● Suitable for high-frequency operation

The high-frequency and high-response clutch and brake enables frequent starting and stopping.

● Compact and easy to handle

The compact design simplifies handling and enables the drive unit of the machine to be mounted into a small area.

● Highly reliable gearhead employed

GC- type and GCH- type gearheads are specifically designed for C·B motors and boast excellent impact resistance, greater strength and high reliability.

● Quick response time

The C·B motor is designed so that it runs continuously. This gives the advantage of a quicker response time and a higher torque in order to move the load.

The output shaft is controlled through the use of the clutch and brake mechanism. The load is stopped by disengaging the clutch and applying the brake. The motor is always affected by the rotor inertia. However, with a clutch and brake unit, the load is not affected by the rotor inertia.

For these reasons, C·B motors boast superior response over other AC standard motors, starting and stopping in considerably less time.

To meet high-frequency, starting and stopping applications, Oriental Motor uses an induction motor for continuous duty. An induction motor is best suited for uni-directional movements. The C·B motor is not suitable for frequent bi-directional starting and stopping motion.

Construction

Flexible Coupling
(Sold separately)
Page A-260



Gearhead
(Sold separately)

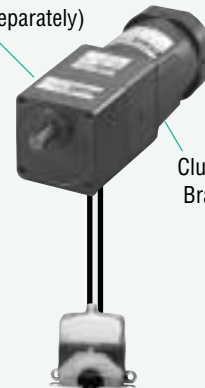

Clutch and
Brake Motor

Capacitor and capacitor cap.
(Included)

Product Lines

To select the appropriate **C-B** motor, consult the output power characteristics on page A-198.



| Model Frame Size | Output Power | | Voltage VAC | Model | Motor Model | Gearhead Model |
|----------------------------|--------------|----|----------------------|---------------------|----------------|---|
| | HP | W | | | | |
| 3.54 in.sq. (90 mm sq.) | 1/18.5 | 40 | Single-Phase 100/115 | CBI540-701WU | 5IK40GN-AW-CB1 | 5GC □ KA (Sold separately) |
| | 1/12.5 | 60 | Single-Phase 100/115 | CBI560-801WU | 5IK60GU-AW-CB1 | 5GCH □ KA (Sold separately) |
| | 1/8 | 90 | Single-Phase 100/115 | CBI590-801WU | 5IK90GU-AW-CB1 | |

Note:

- The **GC-** and **GCH-** type gearheads are designed specifically for use with the **C-B** motor. Other type gearheads may not be connected.
- The motors contain a built-in thermal protector. When a motor overheats for any reason, the thermal protector is opened and the motor stops. When the motor temperature drops, the thermal protector closes and the motor restarts. Be sure to turn the motor off before inspecting.
- The clutch and brake units is not sold separately from the motor.
- The "**U**" at the end of the part number indicate that the unit includes a capacitor. This letter is not listed on the motor nameplate.

General Motor Specifications

(After rated motor operation under normal ambient temperature and humidity.)

| Item | Specifications |
|---------------------------|--|
| Insulation Resistance | 100MΩ or more when 500V DC is applied between the windings and the frame. |
| Dielectric Strength | Sufficient to withstand 1.5kV at 50 and 60Hz applied between the windings and the frame. |
| Temperature Rise | 144°F (80°C) or less measured by the resistance change method after rated motor operation with a gearhead. |
| Insulation Class | Class B 266°F(130°C) |
| Overheat Protection | All models have built-in thermal protectors (Automatic return type) Operating temperature, open: 266°F±41°F (130°C±5°C) close: 179.6°F±59°F (82°C±15°C) |
| Ambient Temperature Range | 14°F~104°F (-10°C~+40°C) |
| Ambient Humidity | 85% maximum (noncondensing) |

Clutch/Brake Specifications

| Model Frame Size | Clutch / Brake | Holding Brake Torque | | Voltage VDC | Input W (at 68°F (20°C)) | Cycle Rates time/minute |
|----------------------------|----------------|----------------------|------|-------------|--------------------------|-------------------------|
| | | oz-in | mN·m | | | |
| 3.54 in.sq. (90 mm sq.) | Clutch | 208 | 1500 | 24 | 8.4 | 100 |
| | Brake | 208 | 1500 | 24 | 6.2 | |

Safety Standards and CE Marking (Motor only)

| Standards | Certification Body | Standards File No. | CE Marking |
|--|--|--------------------|------------------------|
| UL1004 UL547 CAN/CSA-C22.2 No.100 CAN/CSA-C22.2 No.77 | UL | E64197 | Low Voltage Directives |
| EN60950 | VDE | 6751ÜG | |
| EN60034-1 EN60034-5 IEC60034-11 | Conform to EN/IEC Standards. (EN/IEC certifications are scheduled.) | | |

- For installation conditions for EN/IEC standards, see Page D-2.
- Motors are recognized by UL and certified by VDE. The clutch and brake unit is not UL recognized. Recognized name and certified name are motor model name.

■ Structure and Operations of C-B Motor



The photograph above shows the structure of the clutch and brake unit. When no 24V DC is applied to either the clutch coil or brake coil, the output shaft can be rotated by hand.

●Run

When DC 24V is applied to the clutch coil, the armature of the clutch coil is drawn against the clutch plate, transmitting motor rotation to the output shaft.

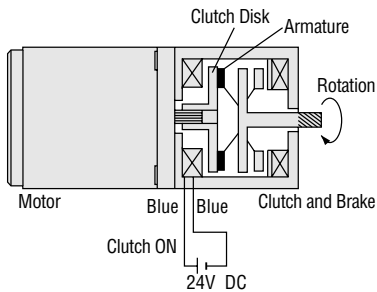

●Stop, Load Holding

By removing the DC 24V from the clutch coil, and, after a certain time lag, applying DC 24V to the brake coil, the output shaft will come to a stop. During braking output shaft is released from the motor shaft, so the shaft may be stopped without being influenced by motor inertia. The motor continues to rotate.

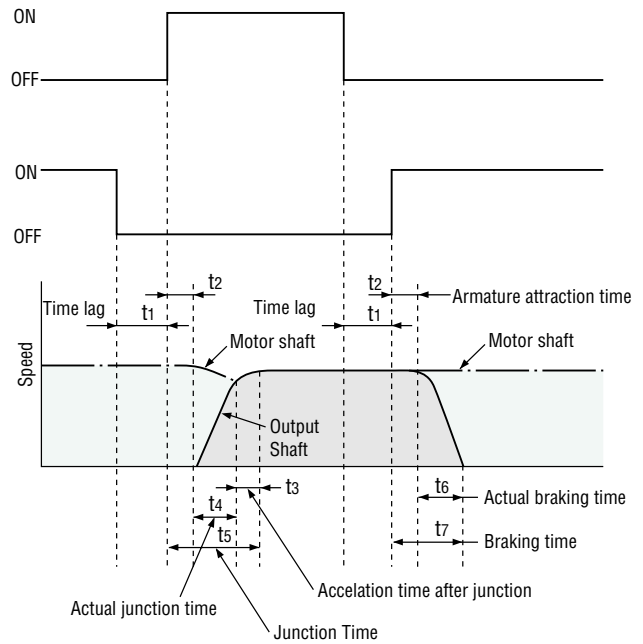
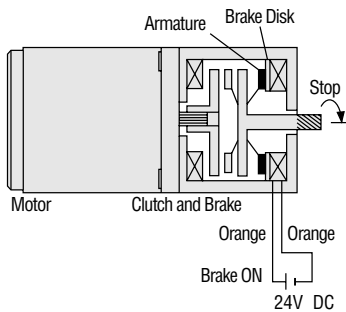

The figure above shows the relationship between the action of the motor shaft and output shaft and the state of excitation of the clutch and brake coils.

●Operation

When operation is shifted from holding the load to moving the load, there is a lag of 20 msec. between the time the brake is released and the time voltage is applied to the clutch. This is to prevent the clutch and brake from engaging at the same time. The time required for the clutch/brake output shaft to reach a constant speed after voltage is applied to the clutch is called the junction time (t_5) and is calculated by adding the following elements:

① Armature attraction time t_2

The time from application of voltage to the clutch coil until contact of the armature with the clutch plate.

② Actual junction time t_4

The time required after the armature comes in contact with the clutch for the clutch/brake output shaft, accelerated by dynamic friction torque, to engage completely with the motor shaft.

③ Acceleration time after junction t_3

The time needed to accelerate back to the required speed if load is applied suddenly to the motor during actual junction time above, causing a temporary drop in speed.

● Braking

When operation is shifted from rotation to stopping or holding of a load, a time lag of about 20 msec. is necessary after the clutch is disengaged before voltage is applied to the brake coil.

The time required after applying voltage to the brake for the clutch/brake output shaft to actually stop is called the braking time (t_7), and is obtained by adding the following elements:

① Armature attraction time t_2

The time from the application of voltage to the clutch coil until contact of the armature with the brake plate.

② Actual braking time t_6

The time from the moment the armature comes in contact with the brake plate until the moment the output shaft comes to a complete stop.

The following graphs indicate examples of junction and braking characteristics.

Junction Characteristics **CBI590-801WU**

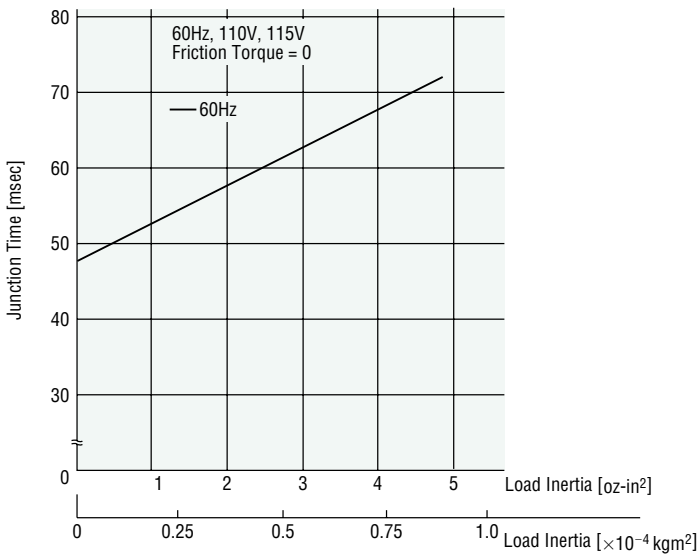

Braking Characteristics **CBI590-801WU**

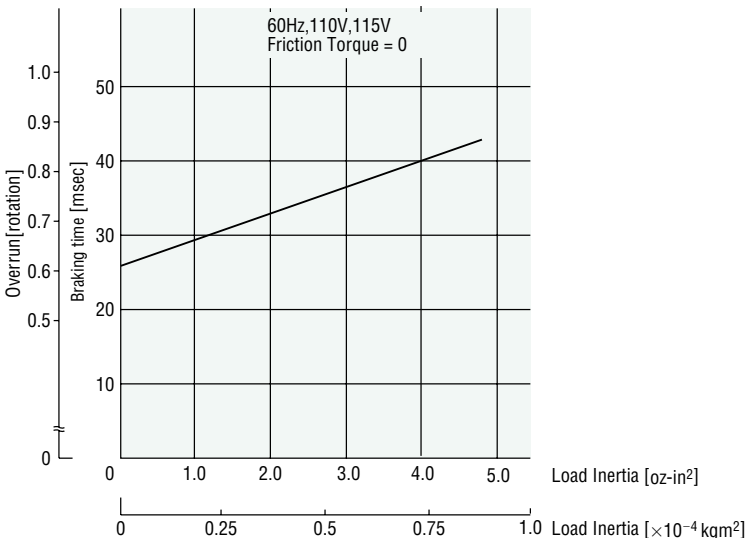

■ GC- and GCH- Type Gearhead for C-B Motors

The **GC-** and **GCH-** type gearheads have been specially designed for use with the **C-B** motor. Although they look much the same as the **GN-** and **GU-** type gearheads, their gearing specifications differ, making them incompatible. Never attempt to connect **GC-** or **GCH-** type gearheads to **GN-** or **GU-** type gearing motors, or to combine **GN-** or **GU-** type gearheads with a **C-B** motor:

Permissible overhung load and permissible thrust load for **GC-** and **GCH-** type gearheads may not exceed the limits given in the table below.

unit = lb (N)

| Model | Gear Ratio | Permissible Overhung Load | | Permissible Thrust Load |
|-------------------------|---------------|-------------------------------|-------------------------------|-------------------------|
| | | 0.4 in. (10mm) from shaft end | 0.8 in. (20mm) from shaft end | |
| 5GC □ KA | 3.6~18 | 55.1(250) | 77.2(350) | 22.0(100) |
| | 30~180 | 66.1(300) | 99.2(450) | |
| 5GCH □ KA | 3.6~9 | 88.2(400) | 110(500) | 33.1(150) |
| | 15~18 | 99.2(450) | 132(600) | |
| | 30~180 | 110(500) | 154(700) | |

● Enter the gear ratio in the box (□) within the model number.

■ Note

- When using **C-B** motors, a DC 24V power supply for the clutch and brake is required in addition to the motor power supply.
- Transformer capacity on the DC power supply should be at least 1.3 times the rated power consumption of the clutch and brake. (See page A-195.)
- Do not try to activate clutch and brake simultaneously. When shifting from clutch to brake or vice versa, leave a time lag of at least 20 msec.

■ Output Power Characteristics

The most appropriate **C-B** motor type may be determined by load torque and load inertia requirements of the motor and gearhead using the output selection charts below.

The curves represent the relationship between load torque and load inertia for a minimum of two million starts and stops. The motor should be operated inside the limits of the load torque load inertia curves given.

Find the clutch and brake motor best suited for your application as follows:

- ① Determine the maximum load torque required at the gearhead output shaft.
- ② Calculate the reflected load inertia effective at the gearhead output shaft.
- ③ Plot the values found in ① and ② into the graph of the applicable speed. The motor model whose characteristic curve is the closest and above the point you entered is the most suitable motor for your purpose.

● Speed at Output Shaft: 500r/min Gear ratio 3.6:1 at 60 Hz

[$\times 10^{-4} \text{kgm}^2$] [lb-in²]

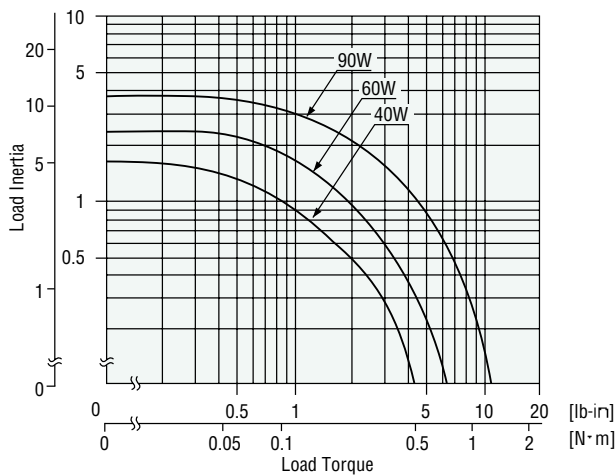

● Speed at Output Shaft: 200r/min Gear ratio 9:1 at 60 Hz

[$\times 10^{-4} \text{kgm}^2$] [lb-in²]

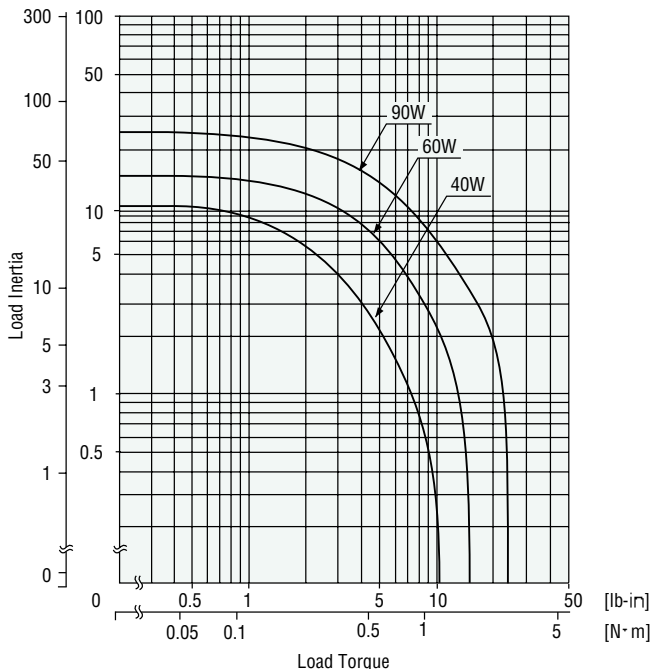

Selection Example

- Required Speed: 300r/min
- Load Torque: 2 lb-in
- Load Inertia: 3 lb-in²

As an example, the value corresponding to these operating requirements have been marked in the application graph for 300r/min.

- The speed indicated is calculated by dividing the motor synchronous speed (1800r/min at 60Hz) by the speed reduction ratio. Note that depending on the load, the actual speed may be 2~20% lower than indicated in the graph.

● Speed at Output Shaft: 300r/min Gear ratio 6:1 at 60 Hz

[$\times 10^{-4} \text{kgm}^2$] [lb-in²]

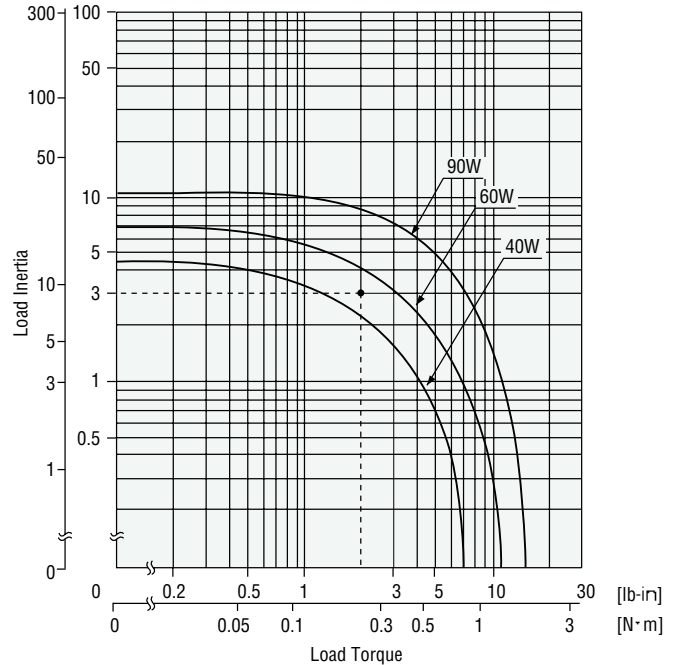

● Speed at Output Shaft: 120r/min Gear ratio 15:1 at 60 Hz

[$\times 10^{-4} \text{kgm}^2$] [lb-in²]

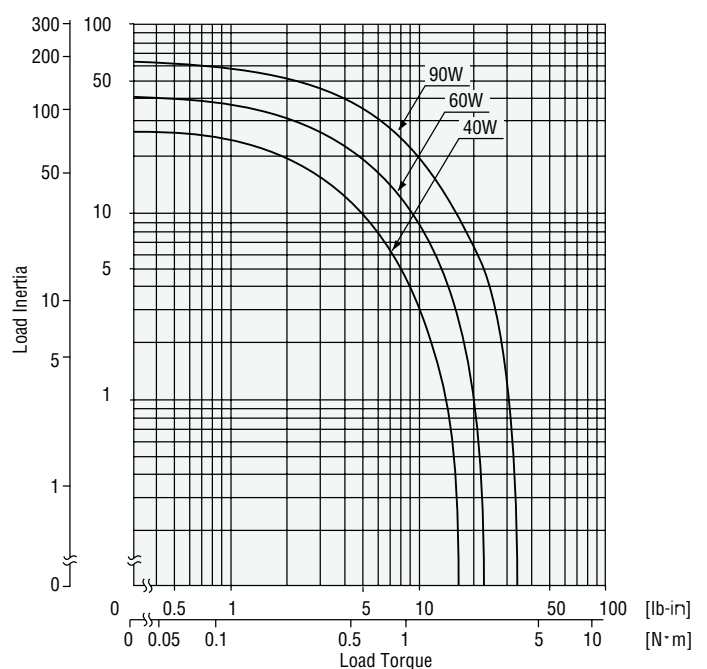

● Speed at Output Shaft: 100r/min
Gear ratio 18:1 at 60 Hz

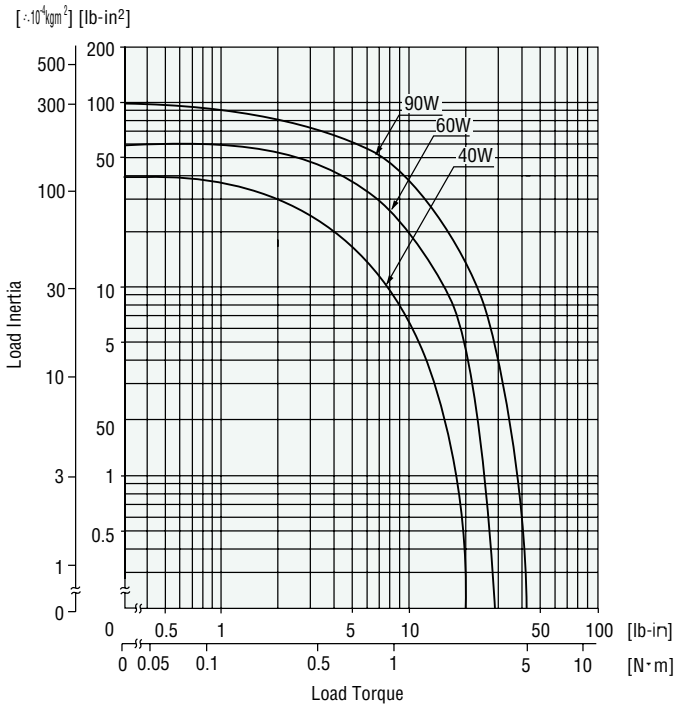

● Speed at Output Shaft: 60r/min
Gear ratio 30:1 at 60 Hz

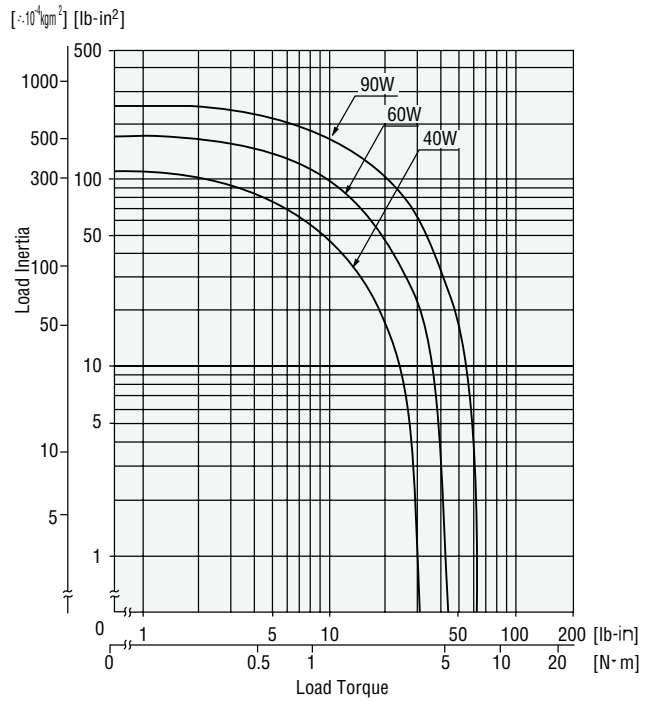

● Speed at Output Shaft: 50r/min
Gear ratio 36:1 at 60 Hz

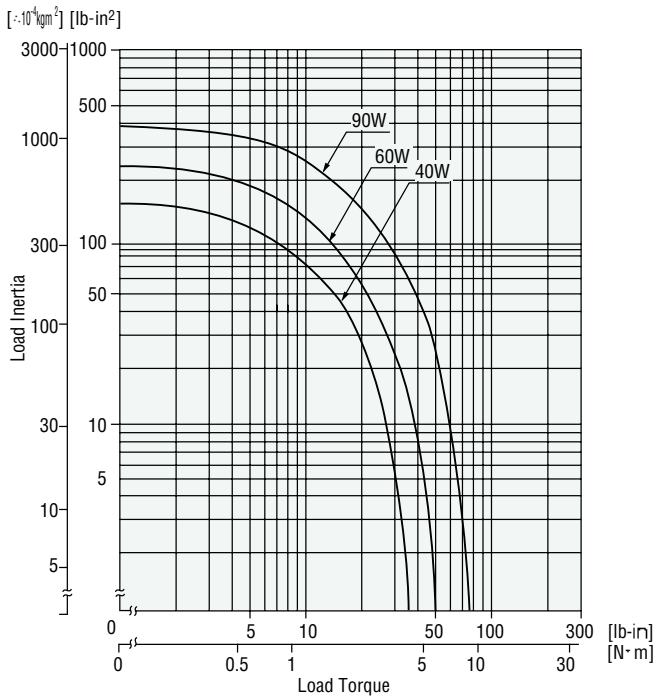

● Speed at Output Shaft: 30r/min or slower
Gear ratio 60:1 or greater at 60 Hz

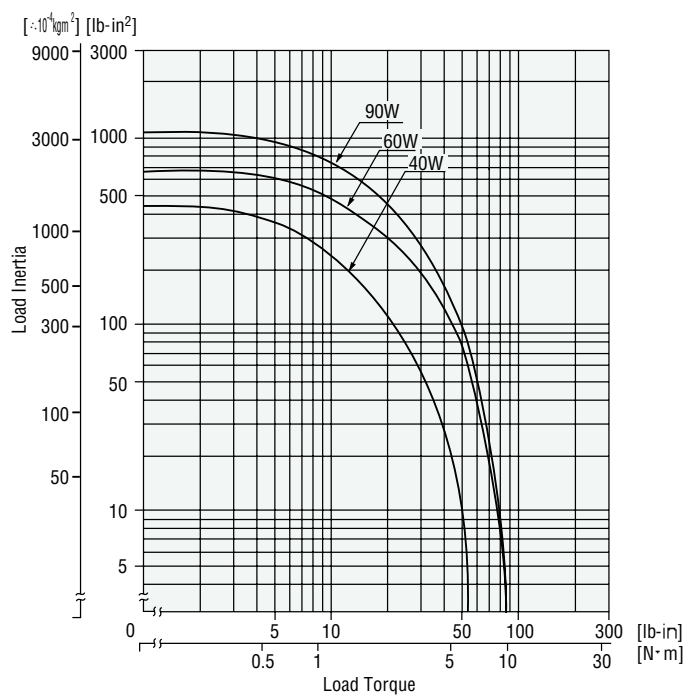

Note: When using a **C.B** motor at an output shaft speed of less than 30r/min (when using with gearheads of speed reduction ratios greater than 60:1 at 60Hz), use the output selection chart entitled "30r/min or slower."

C·B Motors

40W(1/18.5HP) • **60**W(1/12.5HP) • **90**W(1/8HP)



Motor Specifications-Continuous Rating

The gearhead is sold separately. Always use **GC-**, **GCH-** type gearhead with **C·B** unit.



| Model | Output Power | | Voltage V | Frequency Hz | Current A | Rated Speed r/min | Capacitor μ F |
|---------------------|--------------|----|-------------------|-----------------|--------------|----------------------|------------------|
| | HP | W | | | | | |
| CBI540-701WU | 1/18.5 | 40 | Single-Phase 110V | 60 | 0.68 | 1500 | 9.0 |
| | | | Single-Phase 115V | | 0.67 | | |
| CBI560-801WU | 1/12.5 | 60 | Single-Phase 110V | 60 | 1.09 | 1450 | 18.0 |
| | | | Single-Phase 115V | | 1.10 | | |
| CBI590-801WU | 1/8 | 90 | Single-Phase 110V | 60 | 1.45 | 1500 | 20.0 |
| | | | Single-Phase 115V | | 1.44 | | |

Speed Range

| Gear Ratio | 3.6 | 6 | 9 | 15 | 18 | 30 | 36 | 60 | 90 | 120 | 180 |
|------------|-----|-----|-----|-----|-----|----|----|----|----|-----|-----|
| 60Hz | 500 | 300 | 200 | 120 | 100 | 60 | 50 | 30 | 20 | 15 | 10 |

The speed is calculated by dividing the motor's synchronous speed (60 Hz: 1800 r/min) by the gear ratio. The actual loaded speed is 2 ~ 20% less than the displayed value, depending on the amount of the load.

Wiring Diagrams

The direction of motor rotation is as viewed from the shaft end of the motor.

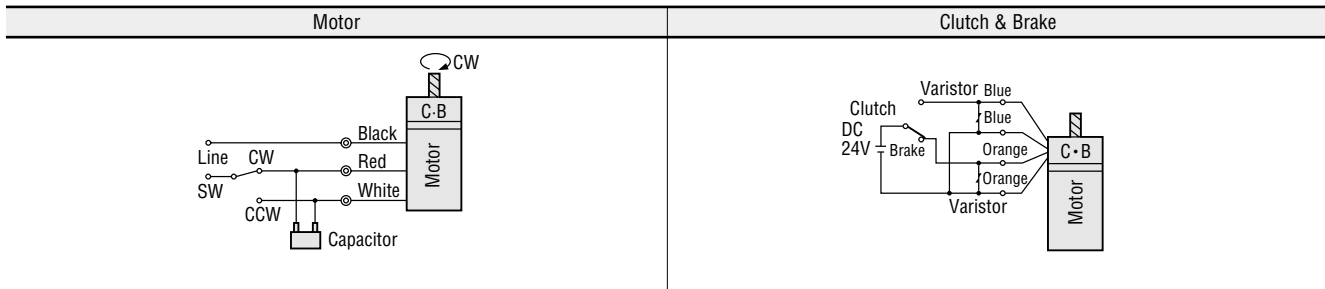

Change the direction of motor rotation only after bringing the motor to a stop.

If an attempt is made to change the direction of rotation while the motor is rotating, the motor may not reverse or it may change its direction of rotation after some delay.

Note: The surge absorber circuit is included with the **C·B** motor. Clutch and brake coil lead wires are non-polar.

Type of Gearhead

| Motor Type | Gearhead Model | Gear Ratio |
|-------------------------|----------------|-----------------------|
| CBI540- | 5GC□KA | 3.6, 6, 9, 15, 18, 30 |
| CBI560-, CBI590- | 5GCH□KA | 36, 60, 90, 120, 180 |

Enter the gear ratio in the box (□) within the gearhead model.

■ Dimensions Scale 1/4, Unit = inch (mm)

● Motor **CBI540-701WU** Weight (Mass): 8.4 lb. (3.8 kg)

● Gearhead **5GC□KA** Weight (Mass): 3.3 lb. (1.5 kg)

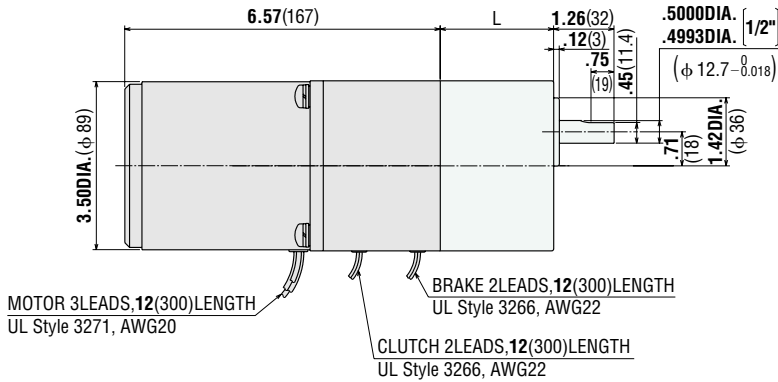

L = 1.65(42) **5GC3.6KA~18KA**

L = 2.36(60) **5GC30KA~180KA**

● Motor **CBI560-801WU** Weight (Mass): 8.8 lb. (4.0 kg)

● Gearhead **5GCH□KA** Weight (Mass): 3.3 lb. (1.5 kg)

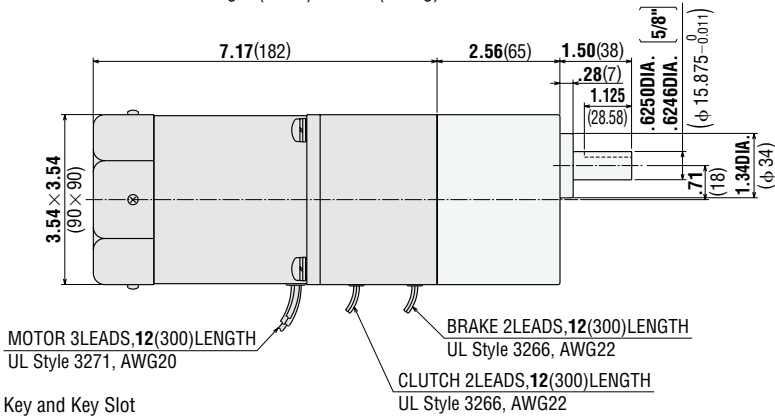

● Key and Key Slot

The key is provided with the **5GCH□KA**

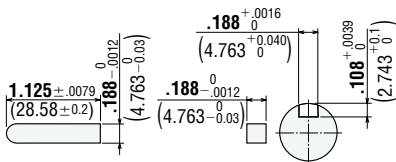

● Motor **CBI590-801WU** Weight (Mass): 9.9 lb. (4.5kg)

● Gearhead **5GCH□KA** Weight (Mass): 3.3 lb.(1.5 kg)

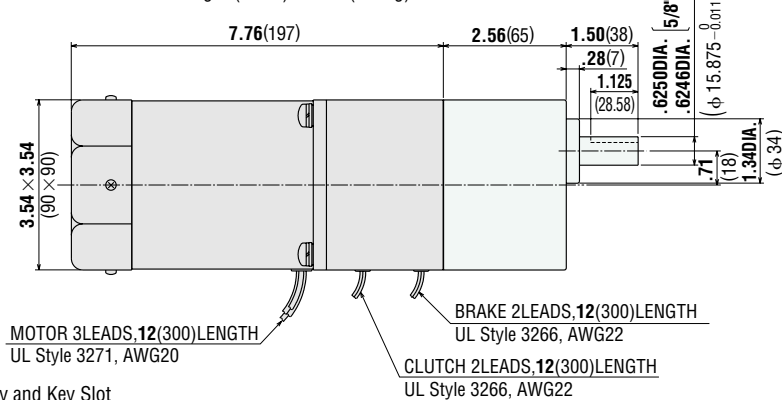

● Key and Key Slot

The key is provided with the **5GCH□KA**

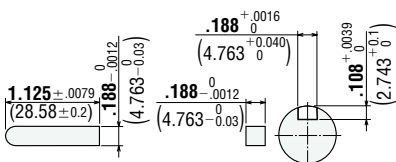

GEARHEAD CASE:

4-.256DIA. (φ 6.5)

CLUTCH-BRAKE CASE:

4-M6 P1.0

.91(23)DEEP

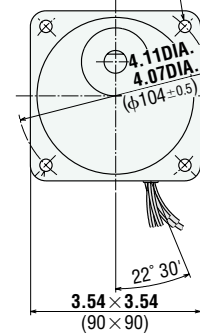

GEARHEAD CASE:

4-.256DIA. (φ 6.5)

CLUTCH-BRAKE CASE:

4-M6 P1.0

.91(23)DEEP

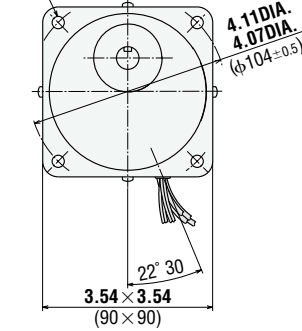

GEARHEAD CASE:

4-.256DIA. (φ 6.5)

CLUTCH-BRAKE CASE:

4-M6 P1.0

.91(23)DEEP

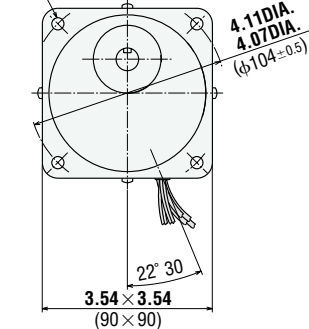

● **Capacitor** (included with the C-B motor) Unit = **inch** (mm)

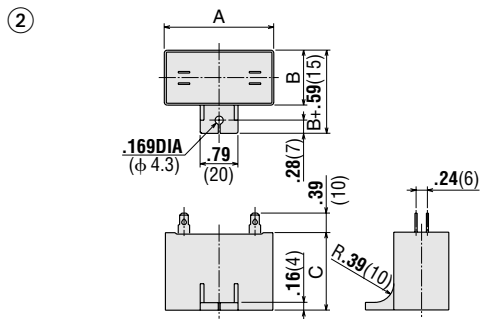
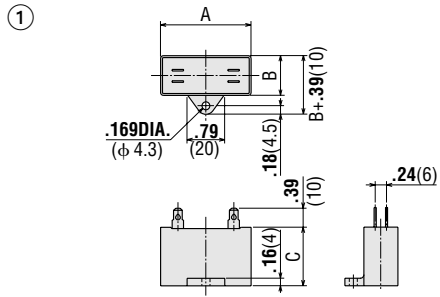

| Motor Model | Capacitor Model | Dimensions inch(mm) | | | Weight oz (g) | No. |
|---------------------|-----------------|---------------------|----------------|--------------|---------------|-----|
| | | A | B | C | | |
| CB1540-701WU | CH90CFAUL | 1.89 (48) | 0.83 (21) | 1.22 (31) | 1.41(40) | ① |
| CB1560-801WU | CH180CFAUL | 2.28 (58) | 0.93 (23.5) | 1.46 (37) | 2.47(70) | ② |
| CB1590-801WU | CH200CFAUL | 2.28 (58) | 1.14 (29) | 1.61 (41) | 3.35(95) | ② |

Capacitor cap is provided with the capacitor.

ORIENTAL MOTOR CATALOG



Washdown Motors

| | |
|---------------------------------------|-------|
| Features and Product Number Code..... | A-204 |
| Specifications | A-206 |
| Wiring Diagrams | A-209 |
| Dimensions..... | A-209 |

WASHDOWN MOTORS

FPW Series

The **FPW Series** motors are splashproof, dust-resistant geared induction motors which conform to the IEC standard IP65. They can be used where they are periodically splashed or washed with water. These washdown induction motors, which are ideal for devices whose movement is in one direction, are available in 25W, 40W, 60W and 90W models.



Product Number Code

FPW 4 25 A - 15 U

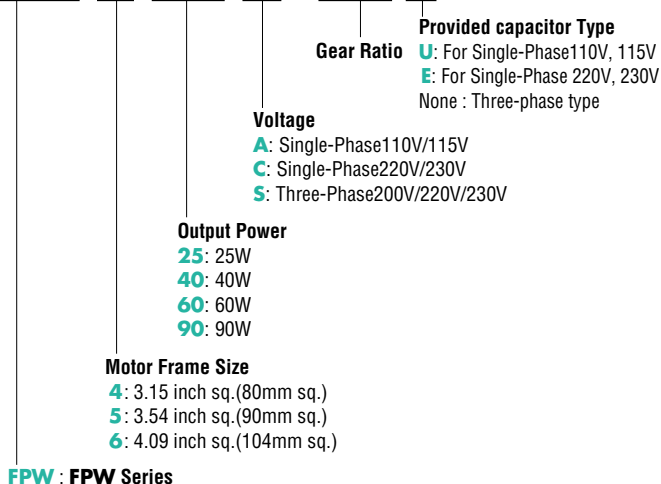

The "U" and "E" at the end of the model name (ordering name) indicate that the unit includes a capacitor. These two letters are not inscribed on the motor nameplate.

Features

● **Dust-resistant, Splashproof Geared Motors**
 Both the motor and gearhead are constructed to be splashproof. They are delivered together in a single unit as a geared motor in order to ensure a proper seal.

● **Special Construction for Splashproof and Dust-resistant Performance**

The construction provides dependable resistance against dust and water by using a specially constructed cable outlet, oil seals on the output shaft, an O-ring in the case/gearhead junction and no external screws.

A special coating and a stainless steel (SUS303 type) shaft provides better anticorrosion protection against both fresh and salt water. The paint is also water repellent.

IP65: The letters "IP" stand for "Ingress Protection" and are followed by two numerical digits which indicate degrees of protection against solid objects and moisture. They are part of the IEC and DIN standards.

FPW series IP65 protection are UL recognized (UL File No.E166348).

A grade of IP65 indicates total dust resistance (the highest grade for protection against contact and intrusion of foreign matter is a "6"), and protection against water jets from all directions (a "5"). This means the structure can be used even when the motor is splashed with water from any direction by a nozzle.

Testing Conditions : A nozzle with an internal diameter of 6.3 mm was used to douse the test specimen from all directions with water at a pressure of 30 kPa and flow of 12.5 l/min for three minutes at a distance of 3 meters. No abnormalities were found.

● **Superb anti-corrosion properties**

High corrosion resistance achieved through special paint coating and stainless shaft.

Precautions

- Cannot be used under water.
- Connect the ground wire to the ground.

Safety Standards and CE Marking

| Standards | Certification Body | Standard File No. | CE Marking |
|---------------------|--------------------|-------------------|-------------|
| UL1004 | | | |
| UL2111 | UL | E 64197 | Low Voltage |
| CAN/CSA-C22.2No.100 | | | Directives |
| CAN/CSA-C22.2No.77 | | | |

■ Designed and Constructed for Dust-and Water-Resistance

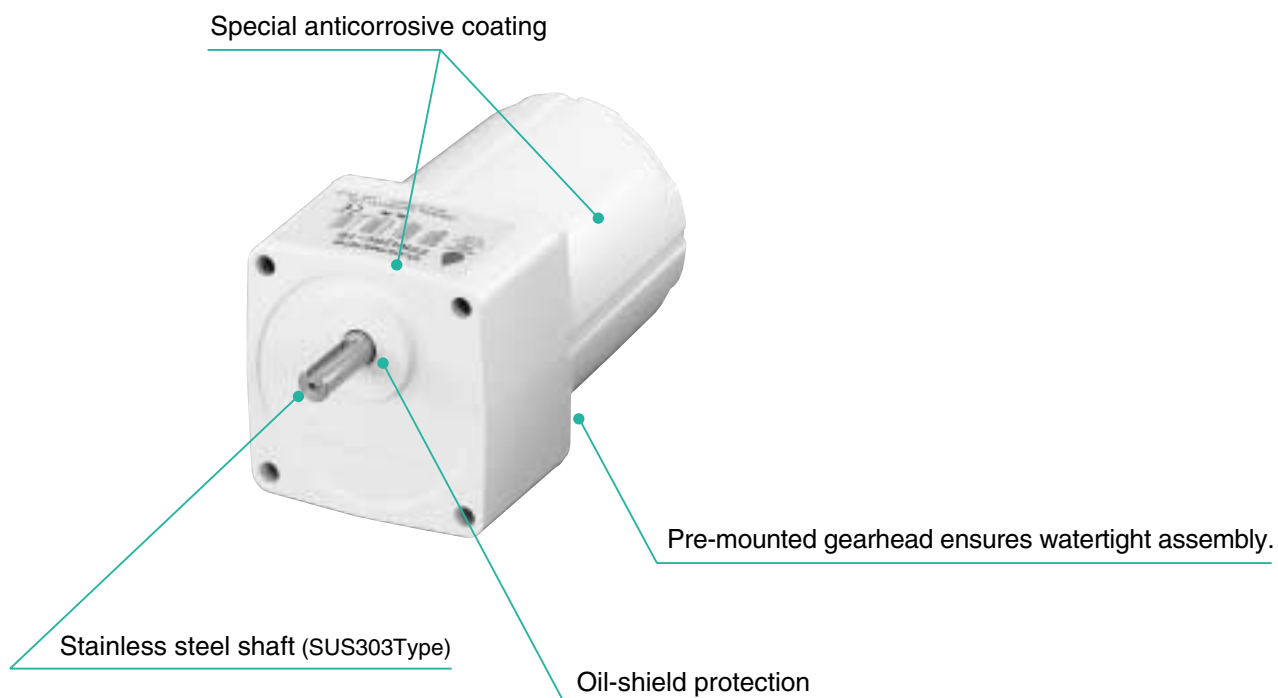

■ Construction



■ Types

| Output Power | Voltage | Model |
|--------------|----------------------------|-------------------|
| 25W | Single-Phase 110V/115V | FPW425A-□U |
| | Single-Phase 220V/230V | FPW425C-□E |
| | Three-Phase 200V/220V/230V | FPW425S-□ |

| Output Power | Voltage | Model |
|--------------|----------------------------|-------------------|
| 40W | Single-Phase 110V/115V | FPW540A-□U |
| | Single-Phase 220V/230V | FPW540C-□E |
| | Three-Phase 200V/220V/230V | FPW540S-□ |

| Output Power | Voltage | Model |
|--------------|----------------------------|-------------------|
| 60W | Single-Phase 110V/115V | FPW560A-□U |
| | Single-Phase 220V/230V | FPW560C-□E |
| | Three-Phase 200V/220V/230V | FPW560S-□ |

| Output Power | Voltage | Model |
|--------------|----------------------------|-------------------|
| 90W | Single-Phase 110V/115V | FPW690A-□U |
| | Single-Phase 220V/230V | FPW690C-□E |
| | Three-Phase 200V/220V/230V | FPW690S-□ |

● Enter the gear ratio in the box (□) within the model number. Eleven gear ratios are available.

■ General Specifications

| Item | Specifications |
|---------------------------|---|
| Insulation Resistance | 100MΩ or more when 500V DC is applied between the windings and the frame under normal ambient temperature and humidity. |
| Dielectric Strength | Sufficient to withstand 1.5kV at 50Hz and 60Hz applied between the windings and the frame under normal ambient temperature and humidity. |
| Temperature Rise | 144°F (80°C) or less measured by the resistance change method after the temperature of the coil has stabilized under normal operation at the rated voltage and frequency. |
| Insulation Class | Class B (266°F [130°C]) |
| Overheat Protection | Built-in thermal protector (Automatic return type) Operating temperature, open :266°F±9°F (130°C±5°C) close : 179.6°F±27°F (82°C±15°C) |
| Ambient Temperature Range | 14°F~104°F(-10°C~+40°C), [Three-Phase 200V : 14°F-122°F(-10°~+50°C)] |
| Degree protection | IP65 |

- Since these are special splashproof, dust-resistant, geared motors, the motor and gear sections cannot be disassembled.
- The capacitors for the motors are neither dustproof nor waterproof.

■ Permissible Overhung Load-Permissible Thrust Load

Unit=lb(N)

| Model | Gear Ratio | 3.6 | 6 | 9 | 15 | 18 | 30 | 36 | 60 | 90 | 120 | 180 | |
|-------------|---------------------------|-------------------------|---|---|----------|----|-----------|----------|----|----|-----|-----|--|
| | | Permissible Thrust Load | | | | | | | | | | | |
| FPW425 type | | 11(50) | | | | | | | | | | | |
| | Permissible Overhung Load | 22(100) | | | | | 44(200) | | | | | | |
| FPW540 type | | 22(100) | | | | | | | | | | | |
| | Permissible Overhung Load | 55(250) | | | | | 66(300) | | | | | | |
| FPW560 type | | 33(150) | | | | | | | | | | | |
| | Permissible Overhung Load | 88(400) | | | 99(450) | | | 110(500) | | | | | |
| FPW690 type | | 44(200) | | | | | | | | | | | |
| | Permissible Overhung Load | 121(550) | | | 143(650) | | | | | | | | |
| | | 176(800) | | | | | 220(1000) | | | | | | |

- The condition of the distance from shaft end on Permissible Overhung Load;
The upper section=0.394 inch (10mm)
The lower section=0.787 inch (20mm)

■ Permissible Inertial Load (J)

Unit=Upper Values:lb-in²/Lower values:×10⁻⁴kgm²

| Model | Gear Ratio | 3.6 | 6 | 9 | 15 | 18 | 30 | 36 | 60 | 90 | 120 | 180 |
|-------------|------------|------|------|------|------|------|-----|------|------|------|------|------|
| FPW425 type | | 1.3 | 3.6 | 8.1 | 22.5 | 32.4 | 90 | 130 | 250 | 250 | 250 | 250 |
| | | 4.02 | 11.2 | 25.1 | 69.8 | 100 | 279 | 402 | 775 | 775 | 775 | 775 |
| FPW540 type | | 3.24 | 9 | 20.3 | 56.3 | 81 | 225 | 324 | 625 | 625 | 625 | 625 |
| | | 9.72 | 27 | 60.8 | 169 | 243 | 675 | 972 | 1875 | 1875 | 1875 | 1875 |
| FPW560 type | | 5.05 | 14 | 31.6 | 87.8 | 126 | 351 | 505 | 975 | 975 | 975 | 975 |
| | | 14.3 | 39.6 | 89.1 | 248 | 356 | 990 | 1426 | 2750 | 2750 | 2750 | 2750 |
| FPW690 type | | 5.05 | 14 | 31.6 | 87.8 | 126 | 351 | 505 | 975 | 975 | 975 | 975 |
| | | 14.3 | 39.6 | 89.1 | 248 | 356 | 990 | 1426 | 2750 | 2750 | 2750 | 2750 |

■ Specifications-Continuous Rating

| Model | Output Power | | Voltage V | Frequency Hz | Current A | Starting Torque | | Rated Torque | | Rated Speed r/min | Capacitor μ F |
|---------------|--------------|----|------------------|-----------------|--------------|-----------------|------|--------------|------|----------------------|----------------------|
| | HP | W | | | | oz-in | mN•n | oz-in | mN•n | | |
| ⓉP FPW425A-□U | 1/30 | 25 | Single-phase 110 | 60 | 0.46 | 16.7 | 120 | 23.6 | 170 | 1450 | 6.5 |
| | | | Single-phase 115 | 60 | 0.46 | 16.7 | 120 | 23.6 | 170 | 1450 | 6.5 |
| ⓉP FPW425C-□E | 1/30 | 25 | Single-phase 220 | 60 | 0.22 | 16.7 | 120 | 23.6 | 170 | 1450 | 1.5 |
| | | | Single-phase 230 | 50 | 0.24 | 16.7 | 120 | 28.5 | 205 | 1200 | 1.5 |
| | | | Single-phase 230 | 60 | 0.22 | 16.7 | 120 | 23.6 | 170 | 1450 | 1.5 |
| ⓉP FPW425S-□ | 1/30 | 25 | Three-phase 200 | 50 | 0.23 | 33.3 | 240 | 26.4 | 190 | 1300 | — |
| | | | Three-phase 200 | 60 | 0.21 | 22.2 | 160 | 22.2 | 160 | 1550 | — |
| | | | Three-phase 220 | 60 | 0.21 | 22.2 | 160 | 22.2 | 160 | 1600 | — |
| | | | Three-phase 230 | 60 | 0.22 | 22.2 | 160 | 22.2 | 160 | 1600 | — |
| ⓉP FPW540A-□U | 1/18.5 | 40 | Single-phase 110 | 60 | 0.68 | 27.8 | 200 | 36.1 | 260 | 1500 | 9 |
| | | | Single-phase 115 | 60 | 0.67 | 27.8 | 200 | 36.1 | 260 | 1500 | 9 |
| ⓉP FPW540C-□E | 1/18.5 | 40 | Single-phase 220 | 60 | 0.35 | 27.8 | 200 | 36.1 | 260 | 1500 | 2.3 |
| | | | Single-phase 230 | 50 | 0.39 | 27.8 | 200 | 41.7 | 300 | 1300 | 2.3 |
| | | | Single-phase 230 | 60 | 0.34 | 27.8 | 200 | 36.1 | 260 | 1500 | 2.3 |
| ⓉP FPW540S-□ | 1/18.5 | 40 | Three-phase 200 | 50 | 0.32 | 55.5 | 400 | 41.7 | 300 | 1300 | — |
| | | | Three-phase 200 | 60 | 0.30 | 36.1 | 260 | 36.1 | 260 | 1550 | — |
| | | | Three-phase 220 | 60 | 0.30 | 36.1 | 260 | 36.1 | 260 | 1600 | — |
| | | | Three-phase 230 | 60 | 0.31 | 36.1 | 260 | 36.1 | 260 | 1600 | — |
| ⓉP FPW560A-□U | 1/12.5 | 60 | Single-phase 110 | 60 | 1.04 | 41.7 | 300 | 56.2 | 405 | 1450 | 12 |
| | | | Single-phase 115 | 60 | 1.02 | 41.7 | 300 | 56.2 | 405 | 1450 | 12 |
| ⓉP FPW560C-□E | 1/12.5 | 60 | Single-phase 220 | 60 | 0.48 | 41.7 | 300 | 56.2 | 405 | 1450 | 3 |
| | 1/13.5 | 55 | Single-phase 230 | 50 | 0.51 | 41.7 | 300 | 59.7 | 430 | 1250 | 3 |
| | 1/12.5 | 60 | Single-phase 230 | 60 | 0.47 | 41.7 | 300 | 56.2 | 405 | 1450 | 3 |
| ⓉP FPW560S-□ | 1/12.5 | 60 | Three-phase 200 | 50 | 0.48 | 83.3 | 600 | 62.5 | 450 | 1300 | — |
| | | | Three-phase 200 | 60 | 0.43 | 69.4 | 500 | 52.8 | 380 | 1550 | — |
| | | | Three-phase 220 | 60 | 0.44 | 69.4 | 500 | 52.8 | 380 | 1600 | — |
| | | | Three-phase 230 | 60 | 0.45 | 69.4 | 500 | 52.8 | 380 | 1600 | — |
| ⓉP FPW690A-□U | 1/8 | 90 | Single-phase 110 | 60 | 1.54 | 55.5 | 400 | 81.2 | 585 | 1500 | 18 |
| | | | Single-phase 115 | 60 | 1.51 | 55.5 | 400 | 81.2 | 585 | 1500 | 18 |
| ⓉP FPW690C-□E | 1/8 | 90 | Single-phase 220 | 60 | 0.68 | 55.5 | 400 | 84.0 | 605 | 1450 | 4 |
| | | | Single-phase 230 | 50 | 0.69 | 55.5 | 400 | 97.2 | 700 | 1250 | 4 |
| | | | Single-phase 230 | 60 | 0.66 | 55.5 | 400 | 84.0 | 605 | 1450 | 4 |
| ⓉP FPW690S-□ | 1/8 | 90 | Three-phase 200 | 50 | 0.54 | 97.2 | 700 | 94.4 | 680 | 1300 | — |
| | | | Three-phase 200 | 60 | 0.51 | 97.2 | 700 | 79.2 | 570 | 1550 | — |
| | | | Three-phase 220 | 60 | 0.50 | 97.2 | 700 | 79.2 | 570 | 1600 | — |
| | | | Three-phase 230 | 60 | 0.49 | 97.2 | 700 | 79.2 | 570 | 1600 | — |

ⓉP : The motors contain built-in thermal protectors. If a motor overheats for any reason, the thermal protector is opened and the motor stops. When the motor temperature drops, the thermal protector closes and the motor restarts. Be sure to turn the motor off before inspecting.

● Enter the gear ratio in the box □ within the model number. There are 11 ratios available, ranging from 3.6 to 180.

The "U" and "E" at the end of the model name (ordering name) indicate that the unit includes a capacitor. These two letters are not inscribed on the motor nameplate.

■ Gearmotor-Torque Table

● Single-phase 115V / 230V 60Hz, Three-phase 230V 60Hz

Unit=Upper value : lb-in
Lower value : N•m

| Model | Speed r/min | 500 | 300 | 200 | 120 | 100 | 60 | 50 | 30 | 20 | 15 | 10 |
|------------|-----------------|------------|------|------|------|------|-------|-------|-------|-------|-------|-------|
| | | Gear Ratio | | | | | | | | | | |
| FPW425A-□U | Rated Torque | 4.3 | 7.2 | 10.4 | 18.3 | 21.7 | 32.2 | 39.1 | 58.3 | 69.6 | 69.6 | 69.6 |
| | | 0.5 | 0.83 | 1.2 | 2.1 | 2.5 | 3.7 | 4.5 | 6.7 | 8 | 8 | 8 |
| FPW425C-□E | Starting Torque | 3.0 | 5.0 | 7.6 | 13 | 14.8 | 22.6 | 27.8 | 41.7 | 61.7 | 69.6 | 69.6 |
| | | 0.35 | 0.58 | 0.87 | 1.5 | 1.7 | 2.6 | 3.2 | 4.8 | 7.1 | 8 | 8 |
| FPW425S-□ | Rated Torque | 4.1 | 6.8 | 10.4 | 16.5 | 20 | 30.4 | 36.5 | 54.8 | 69.6 | 69.6 | 69.6 |
| | Starting Torque | 0.47 | 0.78 | 1.2 | 1.9 | 2.3 | 3.5 | 4.2 | 6.3 | 8 | 8 | 8 |
| FPW540A-□U | Rated Torque | 6.6 | 11.3 | 16.5 | 27.8 | 33 | 49.6 | 59.1 | 87 | 87 | 87 | 87 |
| | | 0.76 | 1.3 | 1.9 | 3.2 | 3.8 | 5.7 | 6.8 | 10 | 10 | 10 | 10 |
| FPW540C-□E | Starting Torque | 5.0 | 8.4 | 13 | 20.9 | 25.2 | 38.3 | 46.1 | 68.7 | 87 | 87 | 87 |
| | | 0.58 | 0.97 | 1.5 | 2.4 | 2.9 | 4.4 | 5.3 | 7.9 | 10 | 10 | 10 |
| FPW540S-□ | Rated Torque | 6.6 | 11.3 | 16.5 | 27.8 | 33 | 49.6 | 59.1 | 87 | 87 | 87 | 87 |
| | Starting Torque | 0.76 | 1.3 | 1.9 | 3.2 | 3.8 | 5.7 | 6.8 | 10 | 10 | 10 | 10 |
| FPW560A-□U | Rated Torque | 10.4 | 17.4 | 26.1 | 38.3 | 46.1 | 69.6 | 83.5 | 130.4 | 130.4 | 130.4 | 130.4 |
| | | 1.2 | 2.0 | 3.0 | 4.4 | 5.3 | 8.0 | 9.6 | 15 | 15 | 15 | 15 |
| FPW560C-□E | Starting Torque | 7.6 | 13 | 19.1 | 28.7 | 34 | 51.3 | 61.7 | 103.5 | 130.4 | 130.4 | 130.4 |
| | | 0.87 | 1.5 | 2.2 | 3.3 | 3.9 | 5.9 | 7.1 | 11.9 | 15 | 15 | 15 |
| FPW560S-□ | Rated Torque | 9.6 | 15.7 | 24.3 | 36.5 | 43.5 | 65.2 | 78.3 | 130.4 | 130.4 | 130.4 | 130.4 |
| | Starting Torque | 1.1 | 1.8 | 2.8 | 4.2 | 5 | 7.5 | 9.0 | 15 | 15 | 15 | 15 |
| FPW690A-□U | Rated Torque | 14.8 | 24.3 | 37.4 | 55.5 | 67 | 111.3 | 133.9 | 201.7 | 260.9 | 260.9 | 260.9 |
| | | 1.7 | 2.8 | 4.3 | 6.4 | 7.7 | 12.8 | 15.4 | 23.2 | 30 | 30 | 30 |
| FPW690C-□E | Starting Torque | 10.4 | 16.5 | 25.2 | 38.3 | 46.1 | 76.5 | 91.3 | 137.4 | 207 | 260.9 | 260.9 |
| | | 1.2 | 1.9 | 2.9 | 4.4 | 5.3 | 8.8 | 10.5 | 15.8 | 23.8 | 30 | 30 |
| FPW690S-□ | Rated Torque | 15.7 | 25.2 | 38.3 | 57.4 | 68.7 | 114.8 | 138.3 | 208.7 | 260.9 | 260.9 | 260.9 |
| | | 1.8 | 2.9 | 4.4 | 6.6 | 7.9 | 13.2 | 15.9 | 24 | 30 | 30 | 30 |
| FPW690C-□E | Starting Torque | 10.4 | 16.5 | 25.2 | 38.3 | 46.1 | 76.5 | 91.3 | 137.4 | 207 | 260.9 | 260.9 |
| | | 1.2 | 1.9 | 2.9 | 4.4 | 5.3 | 8.8 | 10.5 | 15.8 | 23.8 | 30 | 30 |
| FPW690S-□ | Rated Torque | 14.8 | 24.3 | 36.5 | 53.9 | 65.2 | 108.7 | 130.4 | 196.5 | 260.9 | 260.9 | 260.9 |
| | Starting Torque | 1.7 | 2.8 | 4.2 | 6.2 | 7.5 | 12.5 | 15 | 22.6 | 30 | 30 | 30 |

● Enter the gear ratio in the box (□) within the model number.

● The speed is calculated by dividing the motor's synchronous speed (60 Hz : 1800 r/min) by the gear ratio.
The actual speed is 2~20% less than the displayed value, depending on the size of the load.

● Single-phase 230V 50Hz

Unit=Upper value : lb-in
Lower value : N•m

| Model | Speed r/min | 417 | 250 | 167 | 100 | 83 | 50 | 42 | 25 | 17 | 12.5 | 8.3 |
|------------|-----------------|------------|------|------|------|------|------|------|-------|-------|-------|-------|
| | | Gear Ratio | | | | | | | | | | |
| FPW425C-□E | Rated Torque | 5.2 | 8.7 | 13 | 21.7 | 26.1 | 39.1 | 47 | 69.6 | 69.6 | 69.6 | 69.6 |
| | | 0.6 | 1 | 1.5 | 2.5 | 3.0 | 4.5 | 5.4 | 8 | 8 | 8 | 8 |
| FPW540C-□E | Starting Torque | 3.0 | 5.0 | 7.6 | 13 | 14.8 | 22.6 | 27.8 | 41.7 | 61.7 | 69.6 | 69.6 |
| | | 0.35 | 0.58 | 0.87 | 1.5 | 1.7 | 2.6 | 3.2 | 4.8 | 7.1 | 8 | 8 |
| FPW560C-□E | Rated Torque | 7.6 | 13 | 19.1 | 31.3 | 38.3 | 57.4 | 68.7 | 87 | 87 | 87 | 87 |
| | | 0.87 | 1.5 | 2.2 | 3.6 | 4.4 | 6.6 | 7.9 | 10 | 10 | 10 | 10 |
| FPW690C-□E | Starting Torque | 5.0 | 8.4 | 13 | 20.9 | 25.2 | 38.3 | 46.1 | 68.7 | 87 | 87 | 87 |
| | | 0.58 | 0.97 | 1.5 | 2.4 | 2.9 | 4.4 | 5.3 | 7.9 | 10 | 10 | 10 |
| FPW690C-□E | Rated Torque | 11.3 | 18.3 | 27 | 40.9 | 49.6 | 73.9 | 88.7 | 130.4 | 130.4 | 130.4 | 130.4 |
| | | 1.3 | 2.1 | 3.1 | 4.7 | 5.7 | 8.5 | 10.2 | 15 | 15 | 15 | 15 |
| FPW690C-□E | Starting Torque | 7.6 | 13 | 19.1 | 28.7 | 33.9 | 51.3 | 61.7 | 103.5 | 130.4 | 130.4 | 130.4 |
| | | 0.87 | 1.5 | 2.2 | 3.3 | 3.9 | 5.9 | 7.1 | 11.9 | 15 | 15 | 15 |
| FPW690C-□E | Rated Torque | 17.4 | 29.6 | 44.3 | 67 | 80 | 133 | 160 | 240.9 | 260.9 | 260.9 | 260.9 |
| | | 2.0 | 3.4 | 5.1 | 7.7 | 9.2 | 15.3 | 18.4 | 27.7 | 30 | 30 | 30 |
| FPW690C-□E | Starting Torque | 10.4 | 16.5 | 25.2 | 38.3 | 46.1 | 76.5 | 91.3 | 137.4 | 207 | 260.9 | 260.9 |
| | | 1.2 | 1.9 | 2.9 | 4.4 | 5.3 | 8.8 | 10.5 | 15.8 | 23.8 | 30 | 30 |

● Enter the gear ratio in the box within (□) the model number.

● The speed is calculated by dividing the motor's synchronous speed (50 Hz : 1500 r/min) by the gear ratio.
The actual speed is 2~20% less than the displayed value, depending on the size of the load.

Wiring Diagrams

Direction of rotation shown is for the motor shaft rotation as seen from the motor shaft side.

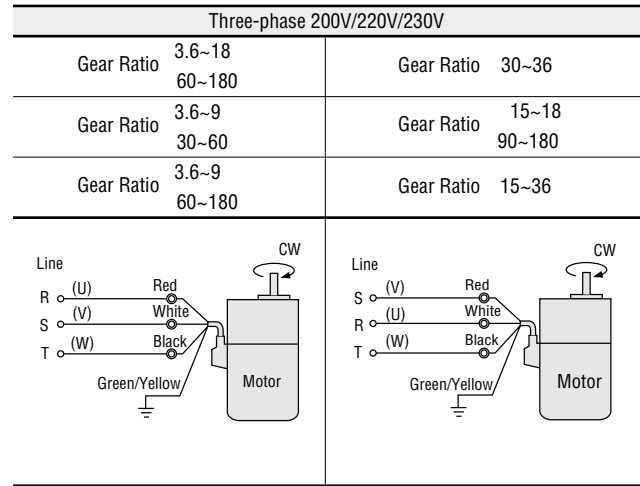
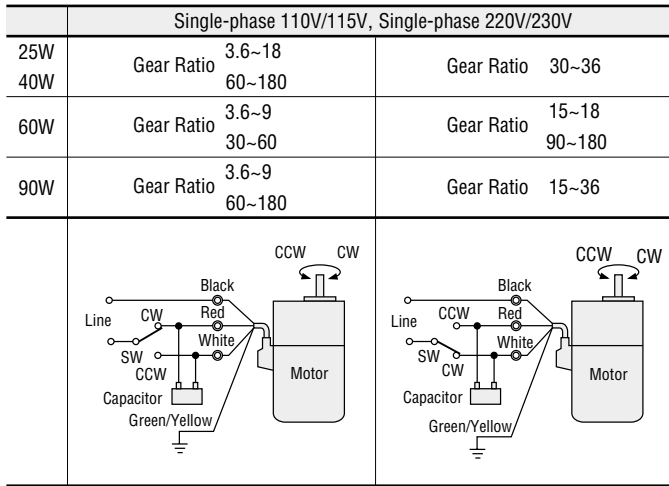

To rotate the motor in a clockwise (CW) direction, flip switch SW to CW.
To rotate it in a counterclockwise (CCW) direction, flip switch SW to CCW.

To change the rotation, change any two connections between U, V and W.

Note : Change the direction of motor rotation only after bringing the motor to a stop. If an attempt is made to change the direction of rotation while the motor is rotating, the motor may ignore the reversing command or change its direction of rotation after some delay.
For added safety, it is advisable to use a ground fault interrupt circuit (GFI) in situations where the motor is likely to get wet during operation.

Wiring precautions

The terminals of the cabtyre cable are not waterproofed.

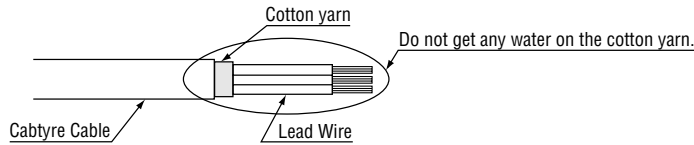

Dimensions

Scale 1/4, Unit = inch (mm)

FPW425A-□U
FPW425C-□E
FPW425S-□

Weight (Mass) : 6.6 lb. (3.0kg)

Key and Key Slot (Scale 1/2)

(The key is provided with motor.)
For 25W, 40W type

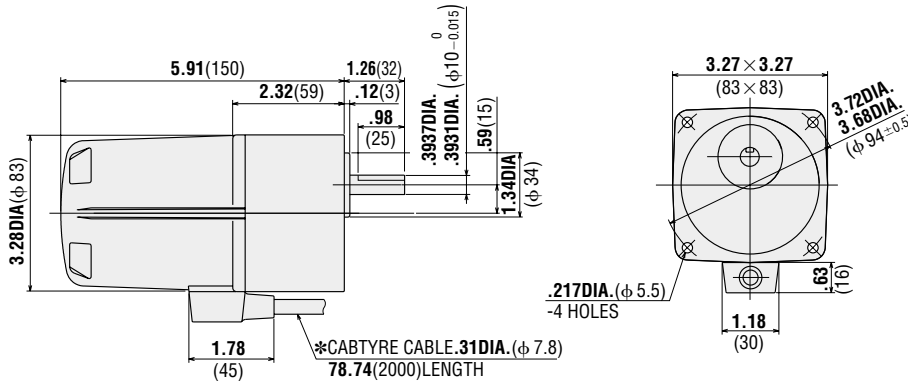

* Cable cores
Motor Lead wire × 3 UL Style 3266, AWG20
Ground Lead wire × 1 UL Style 3266, AWG18

FPW540A-□U
FPW540C-□E
FPW540S-□

Weigh (Mass): 8.8lb.(4.0kg)

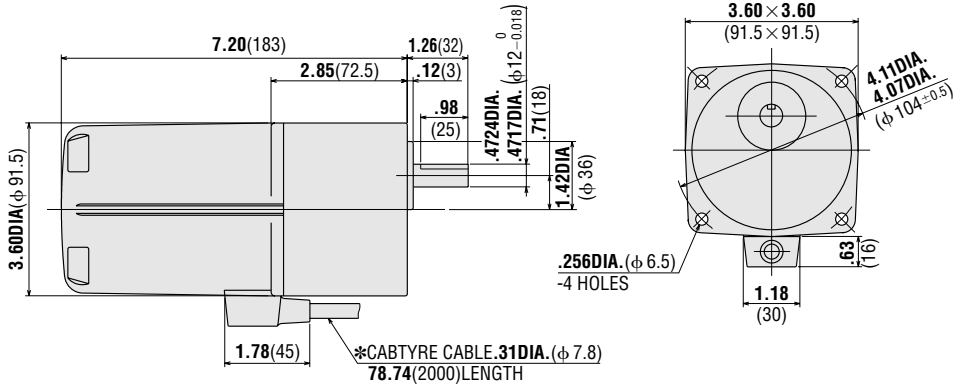

* Cable cores
 Motor Lead wire × 3 UL Style 3266, AWG20
 Ground Lead wire × 1 UL Style 3266, AWG18

FPW560A-□U
FPW560C-□E
FPW560S-□

Weigh (Mass): 11lb.(5.0kg)

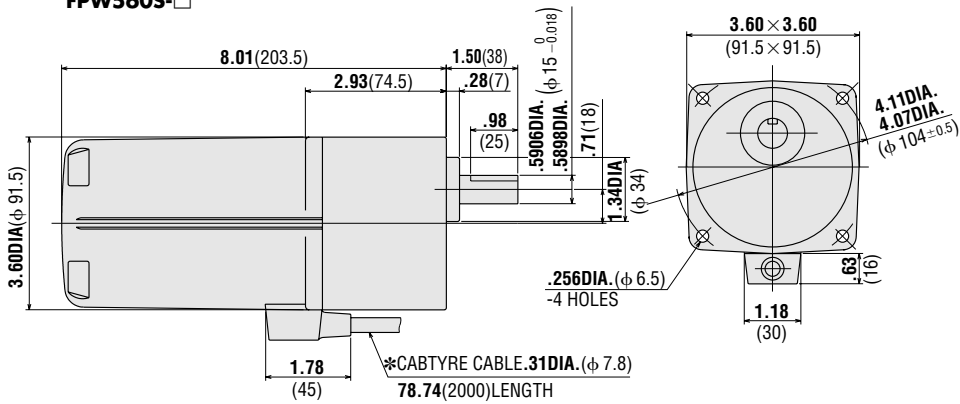

* Cable cores
 Motor Lead wire × 3 UL Style 3266, AWG20
 Ground Lead wire × 1 UL Style 3266, AWG18

● Key and Key Slot (Scale 1/2)
 (The key is provided with motor.)
 For 60W

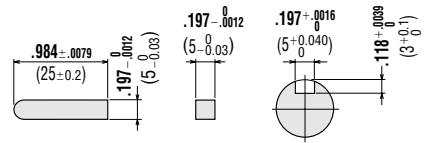

FPW690A-□U
FPW690C-□E
FPW690S-□

Weigh (Mass): 16.5lb.(7.5kg)

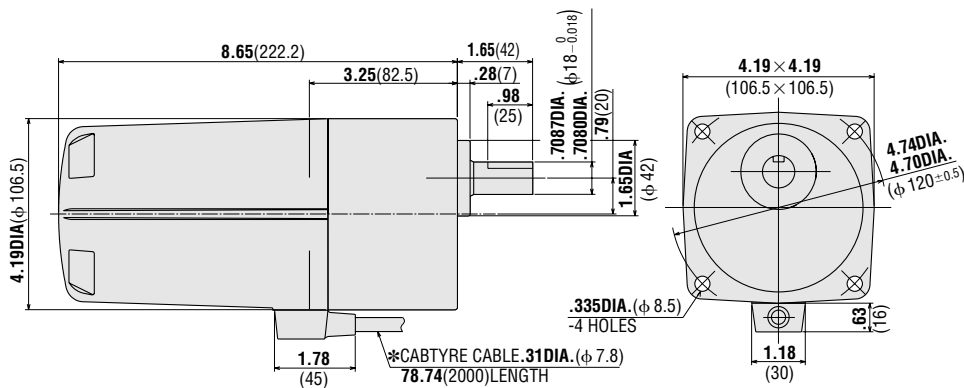

* Cable cores
 Motor Lead wire × 3 UL Style 3266, AWG20
 Ground Lead wire × 1 UL Style 3266, AWG18

● Key and Key Slot (Scale 1/2)
 (The key is provided with motor.)
 For 90W

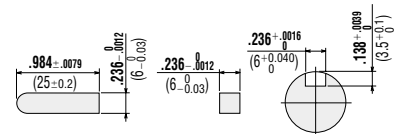

● **Capacitor** (included with the motor)

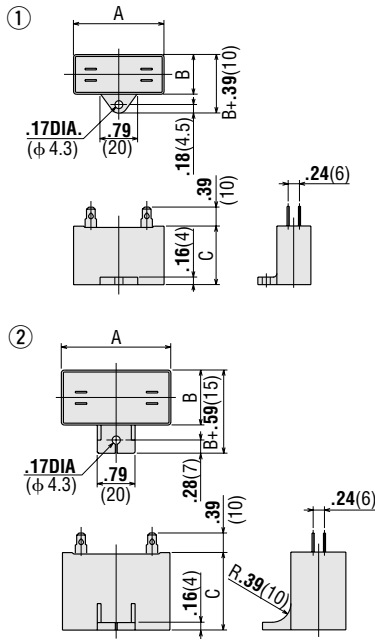

Unit=inch(mm)

| Model | Capacitor Model | A | B | C | Mass (ozg) | No. |
|-------------------|-----------------|-----------|------------|-----------|------------|-----|
| FPW425A-□U | CH65CFAUL | 1.50 (38) | .83 (21) | 1.22 (31) | 1.23 (35) | ① |
| FPW425C-□E | CH15BFAUL | 1.50 (38) | .83 (21) | 1.22 (31) | 1.23 (35) | |
| FPW540A-□U | CH90CFAUL | 1.89 (48) | .83 (21) | 1.22 (31) | 1.41 (40) | ① |
| FPW540C-□E | CH23BFAUL | 1.89 (48) | .83 (21) | 1.22 (31) | 1.41 (40) | |
| FPW560A-□U | CH120CFAUL | 2.28 (58) | .83 (21) | 1.22 (31) | 1.76 (50) | ① |
| FPW560C-□E | CH30BFAUL | 2.28 (58) | .83 (21) | 1.22 (31) | 1.76 (50) | |
| FPW690A-□U | CH180CFAUL | 2.28 (58) | .93 (23.5) | 1.46 (37) | 2.47 (70) | ② |
| FPW690C-□E | CH40BFAUL | 2.28 (58) | .93 (23.5) | 1.46 (37) | 2.47 (70) | |

* Capacitor cap is provided with the capacitor.

● **Screws** (material: stainless steel)

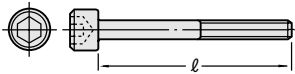

| | l | Size of Screws |
|--------------------|------------------|----------------|
| FPW425 Type | 3.15 inch(80mm) | M5 P0.8 |
| FPW540 Type | 3.54 inch(90mm) | M6 P1.0 |
| FPW560 Type | 3.54 inch(90mm) | M6 P1.0 |
| FPW690 Type | 3.94 inch(100mm) | M8 P1.25 |

4 washes and 4 hexagonal nuts are provided with the screws.

■ **Accessories (sold separately)**

● **Power Relay Box and Extension cables**

A power relay box and a water-resistant extension cable are available. See page [A-272] for more information.



- Power relay box **TB4-0608**
- Extension cable **CC05AC43P** (4cores, 5m)
CC10AC43P (4cores, 10m)

ORIENTAL MOTOR GENERAL CATALOG



Gearheads

Features and Types.....A-214
Right Angle Gearheads.....A-216

Features and Types of Gearheads

Oriental Motor gearheads are specially designed for easy and direct attachment to our AC motors that have a pinion shaft. The gearhead reduces the motor speed which increases the torque. A large number of gear ratios are available for many applications.

● Parallel Shaft Type



● Right Angle Type

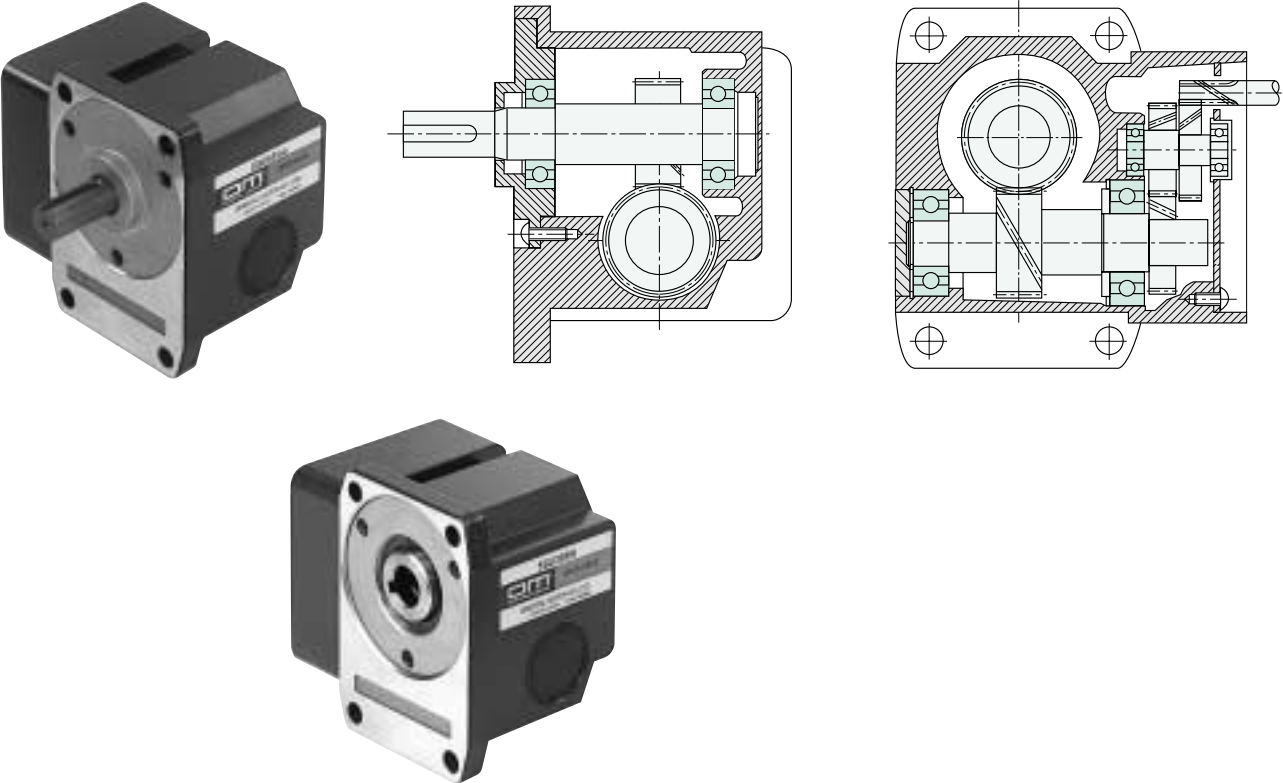

■ Parallel Shaft Type Gearheads

| Application | Gearhead Model | Gear Ratios | Decimal Gearheads |
|---------------------------------------|---|--------------------------|-------------------|
| Light Load | 2GB□KA | 3~360 23 ratios | 2GB10XK |
| | 4GB□KA | 3~360 23 ratios | 4GB10XK |
| Normal Load | 0GN□KA | 3~180 20 ratios | — |
| | 2GN□KA | 3~180 20 ratios | 2GN10XK |
| | 3GN□KA | 3~180 20 ratios | 3GN10XK |
| | 4GN□KA | 3~180 20 ratios | 4GN10XK |
| | 5GN□KA | 3~180 20 ratios | 5GN10XK |
| Heavy Load | 5GU□KA | 3~180 20 ratios | 5GU10XKB |
| | BH6G2-□ | 3.6~180 11 ratios | — |
| Brake Motor (Clutch & Brake Motor) | 5GC□KA | 3.6~180 11 ratios | — |
| | 5GCH□KA | | |
| High Speed (FBLII Series) | FBL575AW, CW, SW-□ (combination type) | 5~200 8 ratios | — |
| | FBL5120AW, CW, SW-□ (combination type) | | |

- Enter the gear ratio in the box(□) within the model number.
- Specifications for gearheads with motors can be found on the individual motor's page.
- See Gearhead Selection on page A-19 for more information on the gear ratios.
- Gearheads in this catalog are shown with inch-sized output-shafts. Metric-sized output shafts are also available. Contact your local sales office or distributor for more information.

■ Right-Angle Type Gearheads

| Gear Frame Size | Type of shaft | Gearhead Model | Gear Ratios | Maximum Permissible Torque |
|-----------------------------|---------------|----------------|-------------------|----------------------------|
| 3.15in. sq. for 25W | Hollow shaft | 4GNRH | 3.6~180 11 ratios | 69 lb-in 8 N•m |
| | Solid shaft | 4GN□RAA | 3.6~180 11 ratios | |
| 3.54in. sq. for 40W | Hollow shaft | 5GN□RH | 3.6~180 11 ratios | 87 lb-in 10 N•m |
| | Solid shaft | 5GN□RAA | 3~180 20 ratios | |
| 3.54in. sq. for 60W and 90W | Hollow shaft | 5GU□RH | 3.6~180 11 ratios | 174 lb-in 20 N•m |
| | Solid shaft | 5GU□RAA | 3~180 20 ratios | |

- Enter the gear ratio in the box(□) within the model name.
- Features and specifications for right angle gearheads are shown on page A-216.
- Gearheads in this catalog are shown with inch-sized output-shafts. Metric-sized output shafts are also available. Contact your local sales office or distributor for more information.

Right-Angle Gearheads

Right-Angle gearheads are flange-mounted gearheads that use worm gears and special helical gears. They allow motors to be installed at right angles to the axis of equipment such as belt conveyors. They are available in hollow shaft **RH** and solid shaft **RA** models and are ideal for keeping equipment compact.



■ Features

- Right angle gearheads with mounting sizes of 3.15 inch square (for 25W) or 3.54 inch square (for 40 W) are available for the **GN** pinion mounting sizes of 3.54 inch (for 60 or 90 W) are available for the **GU** pinion. They can be connected to all Oriental Motor AC motors with the exception of clutch and brake and **FPW** washdown motors.
- The output shaft is perpendicular to the motor shaft, so the motor can be installed perpendicular to the axis being driven.
- Eleven gear ratios are available from 3.6:1 to 180:1. The optimum gear ratio can be selected just as with ordinary gearheads. The maximum permissible torques are also the same as for ordinary gearheads.
- Hollow shaft gearheads allow additional space savings and simpler mechanism designs since they do not require couplings for mounting. Usually, hollow shaft gearheads are locked with a torque arm when mounted so the gearhead does not rotate from the reactive force of the load. When mounted with a torque arm, no centering is needed, so it is faster to mount the gearhead on the device.

■ Product Number Code

5 GU 18 R AA

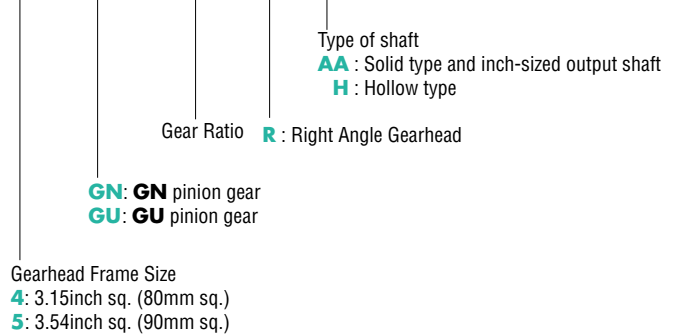

■ Types

| Type of shaft | Gearhead Model |
|---------------|--|
| | 4GN3.6RH~4GN180RH |
| Hollow shaft | 5GN3.6RH~5GN180RH 5GU3.6RH~5GU180RH |
| | 4GN3.6RAA~4GN180RAA |
| Solid shaft | 5GN3RAA~5GN180RAA 5GU3RAA~5GU180RAA |

Specifications

| Gearhead Model | Gear Ratio | Maximum Permissible Torque lb-in (N · m) | Permissible Overhung Load | | Permissible Thrust Load | |
|----------------|----------------|---|---------------------------|---------------------|-------------------------|--------|
| | | | 0.4" from shaft end | 0.8" from shaft end | lb (N) | lb (N) |
| 4GN□RH | 3.6~180 | 69 (8) | 55 (250)* | 44 (220)* | 22 (100) | |
| 5GN□RH | 3.6~180 | 87 (10) | 77 (350)* | 68 (310)* | 44 (200) | |
| 5GU□RH | 3.6~180 | 174 (20) | 123 (560)* | 110 (500)* | 55 (250) | |
| 4GN□RAA | 3.6~18 | 69 (8) | 22 (100) | 33 (150) | 22 (100) | |
| | 30~180 | | 44 (200) | 66 (300) | | |
| 5GN□RAA | 3~18 | 87 (10) | 55 (250) | 77 (350) | 44 (200) | |
| | 25~180 | | 66 (300) | 99 (450) | | |
| | 3~9 | | 88 (400) | 110 (500) | | |
| 5GU□RAA | 12.5~25 | 174 (20) | 99 (450) | 132 (600) | 55 (250) | |
| | 30~180 | | 110 (500) | 154 (700) | | |

* Overhung load values for hollowshaft models are distances from the flange mounting surface.

● Enter the gear ratio in the box(□) within the model name.

● **Caution:** Unlike most worm gear mechanisms, the right-angle gear does not have self-locking capabilities.

Calculating permissible overhung load for hollowshaft models

When the end of the shaft being driven is supported as in the figure below, calculate the permissible overhung load using the following equations.
(This mechanism is the most demanding in terms of overhung load.)

● 4GN□RH

$$\text{Permissible overhung load } W \text{ [lb]} = \frac{2.34}{2.34 + L_p} \times 65 \text{ [lb]}^*$$

* 65 (lb) : Permissible overhung load at flange mounting surface

● 5GN□RH

$$\text{Permissible overhung load } W \text{ [lb]} = \frac{2.76}{2.76 + L_p} \times 88 \text{ [lb]}^*$$

* 88 (lb) : Permissible overhung load at flange mounting surface

● 5GU□RH

$$\text{Permissible overhung load } W \text{ [lb]} = \frac{2.70}{2.70 + L_p} \times 142 \text{ [lb]}^*$$

* 142 (lb) : Permissible overhung load at flange mounting surface

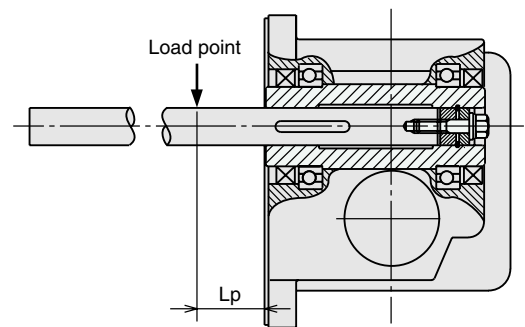

Lp [inch] : Distance from flange mounting surface to overhung load point

Gearhead Efficiency

The permissible torques shown on the following page cover most motor combinations. For motor combinations not covered, use the efficiency value in the table below for your calculations.

When making a selection, remember that the transfer efficiency at startup is lower than at the rated speed.

| Gear Ratio | | 3.6 | 6 | 9 | 15 | 18 | 30 | 36 | 60 | 90 | 120 | 180 |
|----------------|---------|-----|----|-----|-----|----|----|----|-----|-----|-----|-----|
| Gearhead Model | Rating | 40% | | 50% | | | | | 60% | | | |
| | Startup | 40% | | 50% | | | | | 54% | | | |
| 5GN□RH | Rating | 50% | | | 68% | | | | | 60% | | |
| | Startup | 50% | | | 60% | | | | | 54% | | |
| 5GU□RH | Rating | 50% | | | 68% | | | | 60% | | 50% | |
| | Startup | 50% | | | 60% | | | | 54% | | 45% | |
| 4GN□RAA | Rating | | 50 | | | | | | 60% | | | |
| | Startup | | 50 | | | | | | 54% | | | |

| Gear Ratio | | 3 | 3.6 | 5 | 6 | 7.5 | 9 | 12.5 | 15 | 18 | 25 | 30 | 36 | 50 | 60 | 75 | 90 | 100 | 120 | 150 | 180 |
|----------------|---------|---|-----|---|---|-----|---|------|----|----|----|----|----|----|-----|----|----|-----|-----|-----|-----|
| Gearhead Model | Rating | | | | | 68% | | | | | | | | | 60% | | | | | | |
| | Startup | | | | | 60% | | | | | | | | | 54% | | | | | | |
| 5GN□RAA | Rating | | | | | 68% | | | | | | | | | 60% | | | | | 50% | |
| | Startup | | | | | 60% | | | | | | | | | 54% | | | | | 45% | |

■ Gearmotor — Torque Table

- The speed is calculated by dividing the motor's synchronous speed (60Hz: 1800 r/min) by the gear ratio. The actual speed is 2 ~ 20% less than the listed value, depending on the size of the load.
- The efficiency of the gear assembly at startup is lower than the rating, so output torque is lower.
- All output shafts rotate opposite to the direction of motor shaft rotation.

Induction Motors

Hollow shaft (All output shafts rotate opposite to the direction of motor shaft rotation.)

Unit = Upper values:lb-in/Lower values:N·m

| Model | Speed r/min | 500 | 300 | 200 | 120 | 100 | 60 | 50 | 30 | 20 | 15 | 10 |
|---------------------------------------|-------------|------------|----------|----------|-----------|-----------|-----------|-----------|-----------|-----------|------------|------------|
| | Gear Ratio | 3.6 | 6 | 9 | 15 | 18 | 30 | 36 | 60 | 90 | 120 | 180 |
| 4IK25GN-AWU / 4GN□RH | Rating | 2.1 | 3.5 | 6.6 | 13 | 16 | 27 | 32 | 53 | 69 | 69 | 69 |
| | Startup | 0.24 | 0.41 | 0.77 | 1.5 | 1.8 | 3.1 | 3.7 | 6.1 | 8 | 8 | 8 |
| 5IK40GN-AWU / 5GN□RH | Rating | 1.5 | 2.5 | 4.7 | 8.5 | 10 | 17 | 20 | 34 | 51 | 68 | 69 |
| | Startup | 0.17 | 0.29 | 0.54 | 0.97 | 1.2 | 1.9 | 2.3 | 3.9 | 5.8 | 7.8 | 8 |
| 5IK60GU-AWU / 5GU□RH | Rating | 4.1 | 6.8 | 14 | 23 | 28 | 41 | 49 | 81 | 87 | 87 | 87 |
| | Startup | 0.47 | 0.78 | 1.6 | 2.7 | 3.2 | 4.7 | 5.6 | 9.4 | 10 | 10 | 10 |
| 5IK90GU-AWU / 5GU□RH | Rating | 3.1 | 5.2 | 9.4 | 16 | 19 | 28 | 34 | 56 | 84 | 87 | 87 |
| | Startup | 0.36 | 0.6 | 1.1 | 1.8 | 2.2 | 3.2 | 3.9 | 6.5 | 9.7 | 10 | 10 |
| 5IK60GU-AWU / 5GU□RH | Rating | 6.3 | 11 | 21 | 36 | 43 | 63 | 76 | 126 | 174 | 174 | 174 |
| | Startup | 0.73 | 1.2 | 2.5 | 4.1 | 5 | 7.3 | 8.7 | 15 | 20 | 20 | 20 |
| 5IK90GU-AWU / 5GU□RH | Rating | 5 | 8.3 | 15 | 25 | 30 | 45 | 54 | 90 | 135 | 150 | 174 |
| | Startup | 0.58 | 0.96 | 1.7 | 2.9 | 3.5 | 5.2 | 6.2 | 10 | 16 | 17 | 20 |
| 5IK90GU-AWU / 5GU□RH | Rating | 9.1 | 15 | 31 | 52 | 62 | 91 | 110 | 174 | 174 | 174 | 174 |
| | Startup | 1.1 | 1.8 | 3.6 | 6 | 7.2 | 11 | 13 | 20 | 20 | 20 | 20 |
| 5IK90GU-AWU / 5GU□RH | Rating | 7 | 12 | 21 | 35 | 42 | 63 | 76 | 127 | 174 | 174 | 174 |
| | Startup | 0.81 | 1.4 | 2.4 | 4.1 | 4.9 | 7.3 | 8.7 | 15 | 20 | 20 | 20 |

Solid shaft (All output shafts rotate opposite to the direction of motor shaft rotation.)

Unit = Upper values:lb-in/Lower values:N·m

| Model | Speed r/min | 500 | 300 | 200 | 120 | 100 | 60 | 50 | 30 | 20 | 15 | 10 |
|--|-------------|------------|----------|----------|-----------|-----------|-----------|-----------|-----------|-----------|------------|------------|
| | Gear Ratio | 3.6 | 6 | 9 | 15 | 18 | 30 | 36 | 60 | 90 | 120 | 180 |
| 4IK25GN-AWU / 4GN□RAA | Rating | 2.7 | 4.4 | 6.6 | 13 | 16 | 27 | 32 | 53 | 69 | 69 | 69 |
| | Startup | 0.31 | 0.51 | 0.77 | 1.5 | 1.8 | 3.1 | 3.7 | 6.1 | 8 | 8 | 8 |
| 4IK25GN-AWU / 4GN□RAA | Rating | 1.9 | 3.1 | 4.7 | 8.5 | 10 | 17 | 20 | 34 | 51 | 68 | 69 |
| | Startup | 0.22 | 0.36 | 0.54 | 0.97 | 1.2 | 1.9 | 2.3 | 3.9 | 5.8 | 7.8 | 8 |

Unit = Upper values : lb-in/Lower values : N·m

| Model | Speed r/min | 600 | 500 | 360 | 300 | 240 | 200 | 144 | 120 | 100 | 72 | 60 | 50 | 36 | 30 | 24 | 20 | 18 | 15 | 12 | 10 | |
|--|-------------|----------|------------|----------|----------|------------|----------|-------------|-----------|-----------|-----------|-----------|-----------|-----------|-----------|-----------|-----------|------------|------------|------------|------------|-----|
| | Gear Ratio | 3 | 3.6 | 5 | 6 | 7.5 | 9 | 12.5 | 15 | 18 | 25 | 30 | 36 | 50 | 60 | 75 | 90 | 100 | 120 | 150 | 180 | |
| 5IK40GN-AWU / 5GN□RAA | Rating | 4.6 | 5.5 | 7.7 | 9.2 | 12 | 14 | 19 | 23 | 28 | 34 | 41 | 49 | 68 | 81 | 87 | 87 | 87 | 87 | 87 | 87 | 87 |
| | Startup | 0.53 | 0.64 | 0.88 | 1.1 | 1.3 | 1.6 | 2.2 | 2.7 | 3.2 | 3.9 | 4.7 | 5.6 | 7.8 | 9.4 | 10 | 10 | 10 | 10 | 10 | 10 | 10 |
| 5IK40GN-AWU / 5GN□RAA | Rating | 3.1 | 3.8 | 5.2 | 6.3 | 7.8 | 9.4 | 13 | 16 | 19 | 23 | 28 | 34 | 47 | 56 | 70 | 84 | 87 | 87 | 87 | 87 | 87 |
| | Startup | 0.36 | 0.43 | 0.6 | 0.72 | 0.9 | 1.1 | 1.5 | 1.8 | 2.2 | 2.7 | 3.2 | 3.9 | 5.4 | 6.5 | 8.1 | 9.7 | 10 | 10 | 10 | 10 | 10 |
| 5IK60GU-AWU / 5GU□RAA | Rating | 7.2 | 8.6 | 12 | 14 | 18 | 21 | 30 | 36 | 43 | 60 | 63 | 76 | 105 | 126 | 158 | 174 | 174 | 174 | 174 | 174 | 174 |
| | Startup | 0.83 | 0.99 | 1.4 | 1.7 | 2.1 | 2.5 | 3.4 | 4.1 | 5 | 6.9 | 7.3 | 8.7 | 12 | 15 | 18 | 20 | 20 | 20 | 20 | 20 | 20 |
| 5IK60GU-AWU / 5GU□RAA | Rating | 5 | 6 | 8.3 | 10 | 12 | 15 | 21 | 25 | 30 | 42 | 45 | 54 | 75 | 90 | 112 | 135 | 150 | 150 | 174 | 174 | 174 |
| | Startup | 0.58 | 0.69 | 0.96 | 1.2 | 1.4 | 1.7 | 2.4 | 2.9 | 3.5 | 4.8 | 5.2 | 6.2 | 8.6 | 10 | 13 | 16 | 17 | 17 | 20 | 20 | 20 |
| 5IK90GU-AWU / 5GU□RAA | Rating | 10 | 12 | 17 | 21 | 26 | 31 | 43 | 52 | 62 | 86 | 91 | 110 | 152 | 174 | 174 | 174 | 174 | 174 | 174 | 174 | 174 |
| | Startup | 1.2 | 1.4 | 2 | 2.4 | 3 | 3.6 | 5 | 6 | 7.2 | 9.9 | 11 | 13 | 18 | 20 | 20 | 20 | 20 | 20 | 20 | 20 | 20 |
| 5IK90GU-AWU / 5GU□RAA | Rating | 7 | 8.4 | 12 | 14 | 18 | 21 | 29 | 35 | 42 | 59 | 63 | 76 | 105 | 127 | 158 | 174 | 174 | 174 | 174 | 174 | 174 |
| | Startup | 0.81 | 0.97 | 1.4 | 1.6 | 2 | 2.4 | 3.4 | 4.1 | 4.9 | 6.8 | 7.3 | 8.7 | 12 | 15 | 18 | 20 | 20 | 20 | 20 | 20 | 20 |

Reversible Motors

Hollow shaft (All output shafts rotate opposite to the direction of motor shaft rotation.)

Unit = Upper values:lb-in/Lower values:N·m

| Model | Speed r/min | 500 | 300 | 200 | 120 | 100 | 60 | 50 | 30 | 20 | 15 | 10 |
|---------------------------------------|-------------|------------|----------|----------|-----------|-----------|-----------|-----------|-----------|-----------|------------|------------|
| | Gear Ratio | 3.6 | 6 | 9 | 15 | 18 | 30 | 36 | 60 | 90 | 120 | 180 |
| 4RK25GN-AWU / 4GN□RH | Rating | 2.1 | 3.5 | 6.6 | 13 | 16 | 27 | 32 | 53 | 69 | 69 | 69 |
| | Startup | 0.24 | 0.41 | 0.77 | 1.5 | 1.8 | 3.1 | 3.7 | 6.1 | 8 | 8 | 8 |
| 4RK25GN-AWU / 4GN□RH | Rating | 1.7 | 2.9 | 5.5 | 9.8 | 12 | 20 | 24 | 39 | 59 | 69 | 69 |
| | Startup | 0.2 | 0.34 | 0.63 | 1.1 | 1.4 | 2.3 | 2.7 | 4.5 | 6.8 | 8 | 8 |
| 5RK40GN-AWU / 5GN□RH | Rating | 4.2 | 7 | 14 | 24 | 29 | 42 | 51 | 84 | 87 | 87 | 87 |
| | Startup | 0.49 | 0.81 | 1.7 | 2.8 | 3.3 | 4.9 | 5.8 | 9.7 | 10 | 10 | 10 |
| 5RK40GN-AWU / 5GN□RH | Rating | 4.1 | 6.8 | 12 | 20 | 24 | 37 | 44 | 73 | 87 | 87 | 87 |
| | Startup | 0.47 | 0.78 | 1.4 | 2.3 | 2.8 | 4.2 | 5.1 | 8.4 | 10 | 10 | 10 |
| 5RK60GU-AWU / 5GU□RH | Rating | 6.3 | 11 | 21 | 36 | 43 | 63 | 76 | 126 | 174 | 174 | 174 |
| | Startup | 0.73 | 1.2 | 2.5 | 4.1 | 5 | 7.3 | 8.7 | 15 | 20 | 20 | 20 |
| 5RK60GU-AWU / 5GU□RH | Rating | 5.9 | 9.9 | 18 | 30 | 36 | 53 | 64 | 107 | 160 | 174 | 174 |
| | Startup | 0.68 | 1.1 | 2.1 | 3.4 | 4.1 | 6.2 | 7.4 | 12 | 18 | 20 | 20 |
| 5RK90GU-AWU / 5GU□RH | Rating | 9.1 | 15 | 31 | 52 | 62 | 91 | 110 | 174 | 174 | 174 | 174 |
| | Startup | 1.1 | 1.8 | 3.6 | 6 | 7.2 | 11 | 13 | 20 | 20 | 20 | 20 |
| 5RK90GU-AWU / 5GU□RH | Rating | 7 | 12 | 21 | 35 | 42 | 63 | 76 | 127 | 174 | 174 | 174 |
| | Startup | 0.81 | 1.4 | 2.4 | 4.1 | 4.9 | 7.3 | 8.7 | 15 | 20 | 20 | 20 |

Solid shaft (All output shafts rotate opposite to the direction of motor shaft rotation.)

Unit = Upper values:lb-in/Lower values:N-m

| Model | Speed r/min | 500 | 300 | 200 | 120 | 100 | 60 | 50 | 30 | 20 | 15 | 10 |
|--|-------------|-------------|-------------|-------------|------------|-----------|-----------|-----------|-----------|-----------|------------|------------|
| | Gear Ratio | 3.6 | 6 | 9 | 15 | 18 | 30 | 36 | 60 | 90 | 120 | 180 |
| 4RK25GN-AWU / 4GN□RAA | Rating | 2.7 0.31 | 4.4 0.51 | 6.6 0.77 | 13 1.5 | 16 1.8 | 27 3.1 | 32 3.7 | 53 6.1 | 69 8 | 69 8 | 69 8 |
| | Startup | 2.2 0.25 | 3.6 0.42 | 5.5 0.63 | 9.8 1.1 | 12 1.4 | 20 2.3 | 24 2.7 | 39 4.5 | 59 6.8 | 70 8 | 69 8 |

Unit = Upper values : lb-in/Lower values : N-m

| Model | Speed r/min | 600 | 500 | 360 | 300 | 240 | 200 | 144 | 120 | 100 | 72 | 60 | 50 | 36 | 30 | 24 | 20 | 18 | 15 | 12 | 10 | |
|--|-------------|-------------|-------------|-------------|-------------|------------|-----------|-------------|-----------|-----------|-----------|-----------|------------|-----------|-----------|-----------|-----------|------------|------------|------------|------------|-----------|
| | Gear Ratio | 3 | 3.6 | 5 | 6 | 7.5 | 9 | 12.5 | 15 | 18 | 25 | 30 | 36 | 50 | 60 | 75 | 90 | 100 | 120 | 150 | 180 | |
| 5RK40GN-AWU / 5GN□RAA | Rating | 4.8 0.55 | 5.7 0.66 | 8 0.92 | 9.6 1.1 | 12 1.4 | 14 1.7 | 20 2.3 | 24 2.8 | 29 3.3 | 35 4.1 | 42 4.9 | 51 5.8 | 70 8.1 | 84 9.7 | 87 10 | 87 10 | 87 10 | 87 10 | 87 10 | 87 10 | 87 10 |
| | Startup | 4.1 0.47 | 4.9 0.56 | 6.8 0.78 | 8.1 0.94 | 10 1.2 | 12 1.4 | 17 2 | 20 2.3 | 24 2.8 | 30 3.5 | 37 4.2 | 44 5.1 | 61 7 | 73 8.4 | 87 10 | 87 10 | 87 10 | 87 10 | 87 10 | 87 10 | 87 10 |
| 5RK60GU-AWU / 5GU□RAA | Rating | 7.2 0.83 | 8.6 0.99 | 12 1.4 | 14 1.7 | 18 2.1 | 21 2.5 | 30 3.4 | 43 4.1 | 60 5 | 63 6.9 | 76 7.3 | 105 8.7 | 126 12 | 158 15 | 174 18 | 174 20 | 174 20 | 174 20 | 174 20 | 174 20 | 174 20 |
| | Startup | 5.9 0.68 | 7.1 0.82 | 9.9 1.1 | 12 1.4 | 15 1.7 | 18 2.1 | 25 2.9 | 30 3.4 | 36 4.1 | 50 5.7 | 53 6.2 | 64 7.4 | 89 10 | 107 12 | 134 15 | 160 18 | 174 20 | 174 20 | 174 20 | 174 20 | 174 20 |
| 5RK90GU-AWU / 5GU□RAA | Rating | 10 1.2 | 12 1.4 | 17 2 | 21 2.4 | 26 3 | 31 3.6 | 43 5 | 62 6 | 86 7.2 | 91 9.9 | 110 11 | 138 13 | 152 18 | 174 20 | 174 20 | 174 20 | 174 20 | 174 20 | 174 20 | 174 20 | 174 20 |
| | Startup | 9.2 1.1 | 11 1.3 | 15 1.8 | 18 2.1 | 23 2.7 | 28 3.2 | 38 4.4 | 46 5.3 | 55 6.4 | 77 8.9 | 83 9.6 | 100 11 | 138 16 | 166 19 | 174 20 | 174 20 | 174 20 | 174 20 | 174 20 | 174 20 | 174 20 |

Electromagnetic Brake Motors

Hollow shaft (All output shafts rotate opposite to the direction of motor shaft rotation.)

Unit = Upper values:lb-in/Lower values:N-m

| Model | Speed r/min | 500 | 300 | 200 | 120 | 100 | 60 | 50 | 30 | 20 | 15 | 10 |
|--|-------------|-------------|-------------|-------------|------------|-----------|-----------|-----------|-----------|-----------|------------|------------|
| | Gear Ratio | 3.6 | 6 | 9 | 15 | 18 | 30 | 36 | 60 | 90 | 120 | 180 |
| 4RK25GN-AWMU / 4GN□RH | Rating | 2.1 0.24 | 3.5 0.41 | 6.6 0.77 | 13 1.5 | 16 1.8 | 27 3.1 | 32 3.7 | 53 6.1 | 69 8 | 69 8 | 69 8 |
| | Startup | 1.7 0.2 | 2.5 0.34 | 5.5 0.63 | 9.8 1.1 | 12 1.4 | 20 2.3 | 24 2.7 | 39 4.5 | 59 6.8 | 69 8 | 69 8 |
| 5RK40GN-AWMU / 5GN□RH | Rating | 4.2 0.49 | 7 0.81 | 14 1.7 | 24 2.8 | 29 3.3 | 42 4.9 | 51 5.8 | 84 9.7 | 87 10 | 87 10 | 87 10 |
| | Startup | 4.1 0.47 | 6.8 0.78 | 12 1.4 | 20 2.3 | 24 2.8 | 37 4.2 | 44 5.1 | 73 8.4 | 87 10 | 87 10 | 87 10 |
| 5RK60GU-AWMU / 5GU□RH | Rating | 6.3 0.73 | 11 1.2 | 21 2.5 | 36 4.1 | 43 5 | 63 7.3 | 76 8.7 | 126 15 | 174 20 | 174 20 | 174 20 |
| | Startup | 5.9 0.68 | 9.9 1.1 | 18 2.1 | 30 3.4 | 36 4.1 | 53 6.2 | 64 7.4 | 107 12 | 160 18 | 174 20 | 174 20 |
| 5RK90GU-AWMU / 5GU□RH | Rating | 9.1 1.1 | 15 1.8 | 31 3.6 | 52 6 | 62 7.2 | 91 11 | 110 13 | 174 20 | 174 20 | 174 20 | 174 20 |
| | Startup | 9.2 1.1 | 15 1.8 | 28 3.2 | 46 5.3 | 55 6.4 | 83 9.6 | 100 11 | 166 19 | 174 20 | 174 20 | 174 20 |

Solid shaft (All output shafts rotate opposite to the direction of motor shaft rotation.)

Unit = Upper values:lb-in/Lower values:N-m

| Model | Speed r/min | 500 | 300 | 200 | 120 | 100 | 60 | 50 | 30 | 20 | 15 | 10 |
|---|-------------|-------------|-------------|-------------|------------|-----------|-----------|-----------|-----------|-----------|------------|------------|
| | Gear Ratio | 3.6 | 6 | 9 | 15 | 18 | 30 | 36 | 60 | 90 | 120 | 180 |
| 4RK25GN-AWMU / 4GN□RAA | Rating | 2.7 0.31 | 4.4 0.51 | 6.6 0.77 | 13 1.5 | 16 1.8 | 27 3.1 | 32 3.7 | 53 6.1 | 69 8 | 69 8 | 69 8 |
| | Startup | 2.2 0.25 | 3.6 0.42 | 5.5 0.63 | 9.8 1.1 | 12 1.4 | 20 2.3 | 24 2.7 | 39 4.5 | 59 6.8 | 69 8 | 69 8 |

Unit = Upper values : lb-in/Lower values : N-m

| Model | Speed r/min | 600 | 500 | 360 | 300 | 240 | 200 | 144 | 120 | 100 | 72 | 60 | 50 | 36 | 30 | 24 | 20 | 18 | 15 | 12 | 10 | |
|---|-------------|-------------|-------------|-------------|-------------|------------|-----------|-------------|-----------|-----------|-----------|-----------|------------|-----------|-----------|-----------|-----------|------------|------------|------------|------------|-----------|
| | Gear Ratio | 3 | 3.6 | 5 | 6 | 7.5 | 9 | 12.5 | 15 | 18 | 25 | 30 | 36 | 50 | 60 | 75 | 90 | 100 | 120 | 150 | 180 | |
| 5RK40GN-AWMU / 5GN□RAA | Rating | 4.8 0.55 | 5.7 0.66 | 8 0.92 | 9.6 1.1 | 12 1.4 | 14 1.7 | 20 2.3 | 24 2.8 | 29 3.3 | 35 4.1 | 42 4.9 | 51 5.8 | 70 8.1 | 84 9.7 | 87 10 | 87 10 | 87 10 | 87 10 | 87 10 | 87 10 | 87 10 |
| | Startup | 4.1 0.47 | 4.9 0.56 | 6.8 0.78 | 8.1 0.94 | 10 1.2 | 12 1.4 | 17 2 | 20 2.3 | 24 2.8 | 30 3.5 | 37 4.2 | 44 5.1 | 61 7 | 73 8.4 | 87 10 | 87 10 | 87 10 | 87 10 | 87 10 | 87 10 | 87 10 |
| 5RK60GU-AWMU / 5GU□RAA | Rating | 7.2 0.83 | 8.6 0.99 | 12 1.4 | 14 1.7 | 18 2.1 | 21 2.5 | 30 3.4 | 43 4.1 | 60 5 | 63 6.9 | 76 7.3 | 105 8.7 | 126 12 | 158 15 | 174 18 | 174 20 | 174 20 | 174 20 | 174 20 | 174 20 | 174 20 |
| | Startup | 5.9 0.68 | 7.1 0.82 | 9.9 1.1 | 12 1.4 | 15 1.7 | 18 2.1 | 25 2.9 | 30 3.4 | 36 4.1 | 50 5.7 | 53 6.2 | 64 7.4 | 89 10 | 107 12 | 134 15 | 160 18 | 174 20 | 174 20 | 174 20 | 174 20 | 174 20 |
| 5RK90GU-AWMU / 5GU□RAA | Rating | 10 1.2 | 12 1.4 | 17 2 | 21 2.4 | 26 3 | 31 3.6 | 43 5 | 62 6 | 86 7.2 | 91 9.9 | 110 11 | 138 13 | 152 18 | 174 20 | 174 20 | 174 20 | 174 20 | 174 20 | 174 20 | 174 20 | 174 20 |
| | Startup | 9.2 1.1 | 11 1.3 | 15 1.8 | 18 2.1 | 23 2.7 | 28 3.2 | 38 4.4 | 46 5.3 | 55 6.4 | 77 8.9 | 83 9.6 | 100 11 | 138 16 | 166 19 | 174 20 | 174 20 | 174 20 | 174 20 | 174 20 | 174 20 | 174 20 |

Speed Control Motors **US Series**

Hollow shaft (All output shafts rotate opposite to the direction of motor shaft rotation.)

Unit = Upper values:lb-in/Lower values:N-m

| Model \ Gear Ratio | | 3.6 | 6 | 9 | 15 | 18 | 30 | 36 | 60 | 90 | 120 | 180 |
|-------------------------------|-----------|---------------|-------------|-------------|-------------|-------------|------------|------------|-----------|-----------|-----------|-----------|
| US425-401U / 4GN□RH | 1200r/min | 2.5 0.29 | 4.2 0.48 | 7.8 0.9 | 16 1.8 | 19 2.2 | 31 3.6 | 38 4.3 | 63 7.2 | 69 8 | 69 8 | 69 8 |
| | 90r/min | 0.62 0.072 | 1 0.12 | 1.9 0.23 | 3.9 0.45 | 4.7 0.54 | 7.8 0.9 | 9.3 1.1 | 16 1.8 | 23 2.7 | 31 3.6 | 47 5.4 |
| | Startup | 1.3 0.15 | 2.2 0.25 | 4.1 0.47 | 7.4 0.85 | 8.9 1 | 15 1.7 | 18 2 | 30 3.4 | 44 5.1 | 59 6.8 | 69 8 |
| US540-401U / 5GN□RH | 1200r/min | 4.1 0.47 | 6.8 0.78 | 14 1.6 | 23 2.7 | 28 3.2 | 41 4.7 | 49 5.6 | 81 9.4 | 87 10 | 87 10 | 87 10 |
| | 90r/min | 1.1 0.13 | 1.8 0.21 | 3.7 0.43 | 6.2 0.71 | 7.4 0.86 | 11 1.3 | 13 1.5 | 22 2.5 | 33 3.8 | 44 5 | 65 7.6 |
| | Startup | 2.8 0.32 | 4.7 0.54 | 8.4 0.97 | 14 1.6 | 17 1.9 | 25 2.9 | 30 3.5 | 51 5.8 | 76 8.7 | 87 10 | 87 10 |
| US560-501U / 5GU□RH | 1200r/min | 7.7 0.88 | 13 1.5 | 26 3 | 43 5 | 52 6 | 77 8.8 | 92 11 | 153 18 | 174 20 | 174 20 | 174 20 |
| | 90r/min | 3.1 0.36 | 5.2 0.6 | 11 1.2 | 18 2 | 21 2.4 | 31 3.6 | 38 4.3 | 63 7.2 | 94 11 | 104 12 | 156 18 |
| | Startup | 4.5 0.51 | 7.4 0.86 | 13 1.5 | 22 2.6 | 27 3.1 | 40 4.6 | 48 5.5 | 80 9.2 | 120 14 | 134 15 | 174 20 |
| US590-501U / 5GU□RH | 1200r/min | 11 1.3 | 19 2.2 | 39 4.5 | 65 7.4 | 78 8.9 | 114 13 | 137 16 | 174 20 | 174 20 | 174 20 | 174 20 |
| | 90r/min | 3.1 0.36 | 5.2 0.6 | 11 1.2 | 18 2 | 21 2.4 | 31 3.6 | 38 4.3 | 63 7.2 | 94 11 | 104 12 | 156 18 |
| | Startup | 6.3 0.73 | 11 1.2 | 19 2.2 | 32 3.6 | 38 4.4 | 57 6.6 | 68 7.9 | 114 13 | 171 20 | 174 20 | 174 20 |

Solid shaft (All output shafts rotate opposite to the direction of motor shaft rotation.)

Unit = Upper values:lb-in/Lower values:N-m

| Model \ Gear Ratio | | 3.6 | 6 | 9 | 15 | 18 | 30 | 36 | 60 | 90 | 120 | 180 |
|--------------------------------|-----------|--------------|-------------|-------------|-------------|-------------|------------|------------|-----------|-----------|-----------|-----------|
| US425-401U / 4GN□RAA | 1200r/min | 3.1 0.36 | 5.2 0.6 | 7.8 0.9 | 16 1.8 | 19 2.2 | 31 3.6 | 38 4.3 | 63 7.2 | 69 8 | 69 8 | 69 8 |
| | 90r/min | 0.78 0.09 | 1.3 0.15 | 1.9 0.23 | 3.9 0.45 | 4.7 0.54 | 7.8 0.9 | 9.3 1.1 | 16 1.8 | 23 2.7 | 31 3.6 | 47 5.4 |
| | Startup | 1.6 0.19 | 2.7 0.32 | 4.1 0.47 | 7.4 0.85 | 8.9 1 | 15 1.7 | 18 2 | 30 3.4 | 44 5.1 | 59 6.8 | 69 8 |

Unit = Upper values : lb-in/Lower values : N-m

| Model \ Gear Ratio | | 3 | 3.6 | 5 | 6 | 7.5 | 9 | 12.5 | 15 | 18 | 25 | 30 | 36 | 50 | 60 | 75 | 90 | 100 | 120 | 150 | 180 |
|--------------------------------|-----------|-------------|-------------|-------------|-------------|-------------|-------------|------------|-------------|-------------|------------|-----------|-----------|-----------|-----------|-----------|-----------|-----------|-----------|-----------|-----------|
| US540-401U / 5GN□RAA | 1200r/min | 4.6 0.53 | 5.5 0.64 | 7.7 0.88 | 9.2 1.1 | 12 1.3 | 14 1.6 | 19 2.2 | 23 2.7 | 28 3.2 | 34 3.9 | 41 4.7 | 49 5.6 | 68 7.8 | 81 9.4 | 87 10 | 87 10 | 87 10 | 87 10 | 87 10 | 87 10 |
| | 90r/min | 1.2 0.14 | 1.5 0.17 | 2.1 0.24 | 2.5 0.29 | 3.1 0.36 | 3.7 0.43 | 5.2 0.6 | 6.2 0.71 | 7.4 0.86 | 9.1 1.1 | 11 1.3 | 13 1.5 | 18 2.1 | 22 2.5 | 27 3.2 | 33 3.8 | 36 4.2 | 44 5 | 55 6.3 | 65 7.6 |
| | Startup | 2.8 0.32 | 3.4 0.39 | 4.7 0.54 | 5.6 0.65 | 7 0.81 | 8.4 0.97 | 12 1.4 | 14 1.6 | 17 1.9 | 21 2.4 | 25 2.9 | 30 3.5 | 36 4.3 | 42 4.9 | 51 5.8 | 63 7.3 | 76 8.7 | 84 9.7 | 87 10 | 87 10 |
| US560-501U / 5GU□RAA | 1200r/min | 8.7 1 | 10 1.2 | 14 1.7 | 17 2 | 22 2.5 | 26 3 | 36 4.2 | 43 5 | 52 6 | 72 8.3 | 77 8.8 | 92 11 | 128 15 | 153 18 | 174 20 | 174 20 | 174 20 | 174 20 | 174 20 | 174 20 |
| | 90r/min | 3.5 0.41 | 4.3 0.49 | 5.9 0.68 | 7.1 0.82 | 8.9 1 | 11 1.2 | 15 1.7 | 18 2 | 21 2.4 | 30 3.4 | 31 3.6 | 38 4.3 | 52 6 | 63 7.2 | 78 9 | 94 11 | 104 12 | 104 12 | 130 15 | 156 18 |
| | Startup | 4.5 0.51 | 5.3 0.62 | 7.4 0.86 | 8.9 1 | 11 1.3 | 13 1.5 | 19 2.1 | 22 2.6 | 27 3.1 | 37 4.3 | 40 4.6 | 48 5.5 | 67 7.7 | 80 9.2 | 100 12 | 120 14 | 134 15 | 134 15 | 167 19 | 174 20 |
| US590-501U / 5GU□RAA | 1200r/min | 13 1.5 | 16 1.8 | 22 2.5 | 26 3 | 32 3.7 | 39 4.5 | 54 6.2 | 65 7.4 | 78 8.9 | 108 12 | 114 13 | 137 16 | 174 20 | 174 20 | 174 20 | 174 20 | 174 20 | 174 20 | 174 20 | 174 20 |
| | 90r/min | 3.5 0.41 | 4.3 0.49 | 5.9 0.68 | 7.1 0.82 | 8.9 1 | 11 1.2 | 15 1.7 | 18 2 | 21 2.4 | 30 3.4 | 31 3.6 | 38 4.3 | 52 6 | 63 7.2 | 78 9 | 94 11 | 104 12 | 104 12 | 130 15 | 156 18 |
| | Startup | 6.3 0.73 | 7.6 0.87 | 11 1.2 | 13 1.5 | 16 1.8 | 19 2.2 | 26 3 | 32 3.6 | 38 4.4 | 53 6.1 | 57 6.6 | 68 7.9 | 95 11 | 114 13 | 142 16 | 171 20 | 174 20 | 174 20 | 174 20 | 174 20 |

Speed Control Motors **SC Series Induction Type**

Hollow shaft (All output shafts rotate opposite to the direction of motor shaft rotation.)

Unit = Upper values:lb-in/Lower values:N-m

| Model \ Gear Ratio | | 3.6 | 6 | 9 | 15 | 18 | 30 | 36 | 60 | 90 | 120 | 180 |
|---------------------------------------|-----------|---------------|-------------|-------------|-------------|-------------|-------------|-------------|-----------|-----------|-----------|-----------|
| SC425-401WU / 4GN□RH | 1200r/min | 2 0.23 | 3.3 0.38 | 6.2 0.72 | 12 1.4 | 15 1.7 | 25 2.9 | 30 3.5 | 50 5.8 | 69 8 | 69 8 | 69 8 |
| | 90r/min | 0.54 0.062 | 0.9 0.1 | 1.7 0.19 | 3.4 0.39 | 4.1 0.46 | 6.8 0.77 | 8.1 0.93 | 14 1.5 | 20 2.3 | 27 3.1 | 41 4.6 |
| | Startup | 1.3 0.14 | 2.1 0.24 | 3.9 0.45 | 7 0.81 | 8.4 0.97 | 14 1.6 | 17 1.9 | 28 3.2 | 42 4.9 | 56 6.5 | 69 8 |
| SC540-401WU / 5GN□RH | 1200r/min | 5 0.58 | 8.3 0.96 | 17 2 | 28 3.3 | 34 3.9 | 50 5.8 | 60 6.9 | 87 10 | 87 10 | 87 10 | 87 10 |
| | 90r/min | 0.96 0.099 | 1.4 0.17 | 2.9 0.34 | 4.8 0.56 | 5.8 0.67 | 8.6 0.99 | 10 1.2 | 17 2 | 26 3 | 34 4 | 51 5.9 |
| | Startup | 2.7 0.31 | 4.4 0.51 | 8 0.92 | 13 1.5 | 16 1.8 | 24 2.8 | 29 3.3 | 48 5.5 | 72 8.3 | 87 10 | 87 10 |
| SC560-501WU / 5GU□RH | 1200r/min | 6.1 0.7 | 10 1.2 | 21 2.4 | 35 4 | 41 4.8 | 61 7 | 73 8.4 | 122 14 | 174 20 | 174 20 | 174 20 |
| | 90r/min | 1.5 0.17 | 2.5 0.29 | 5 0.58 | 8.4 0.97 | 10 1.2 | 15 1.7 | 18 2.1 | 30 3.4 | 45 5.1 | 50 5.7 | 74 8.6 |
| | Startup | 5.5 0.63 | 9.1 1.1 | 16 1.9 | 27 3.2 | 33 3.8 | 49 5.7 | 59 6.8 | 98 11 | 148 17 | 164 19 | 174 20 |

Solid shaft (All output shafts rotate opposite to the direction of motor shaft rotation.)

Unit = Upper values:lb-in/Lower values:N-m

| Model \ Gear Ratio | | 3.6 | 6 | 9 | 15 | 18 | 30 | 36 | 60 | 90 | 120 | 180 |
|--|-----------|---------------|-------------|-------------|-------------|-------------|-------------|-------------|-----------|-----------|-----------|-----------|
| SC425-401WU / 4GN□RAA | 1200r/min | 2.5 0.29 | 4.2 0.48 | 6.2 0.72 | 12 1.4 | 15 1.7 | 25 2.9 | 30 3.5 | 50 5.8 | 69 8 | 69 8 | 69 8 |
| | 90r/min | 0.68 0.077 | 1.1 0.13 | 1.7 0.19 | 3.4 0.39 | 4.1 0.46 | 6.8 0.77 | 8.1 0.93 | 14 1.5 | 20 2.3 | 27 3.1 | 41 4.6 |
| | Startup | 1.6 0.18 | 2.6 0.3 | 3.9 0.45 | 7 0.81 | 8.4 0.97 | 14 1.6 | 17 1.9 | 28 3.2 | 42 4.9 | 56 6.5 | 69 8 |

Unit = Upper values : lb-in/Lower values : N-m

| Model \ Gear Ratio | | 3 | 3.6 | 5 | 6 | 7.5 | 9 | 12.5 | 15 | 18 | 25 | 30 | 36 | 50 | 60 | 75 | 90 | 100 | 120 | 150 | 180 |
|--|-----------|--------------|-------------|-------------|-------------|-------------|-------------|-----------|-------------|-------------|-------------|-------------|-----------|-----------|-----------|-----------|-----------|-----------|-----------|-----------|-----------|
| SC540-401WU / 5GN□RAA | 1200r/min | 5.7 0.65 | 6.8 0.78 | 9.4 1.1 | 11 1.3 | 14 1.6 | 17 2 | 24 2.7 | 28 3.3 | 34 3.9 | 42 4.8 | 50 5.8 | 60 6.9 | 83 9.6 | 87 10 | 87 10 | 87 10 | 87 10 | 87 10 | 87 10 | 87 10 |
| | 90r/min | 0.97 0.11 | 1.2 0.13 | 1.6 0.19 | 1.9 0.22 | 2.4 0.28 | 2.9 0.34 | 4 0.47 | 4.8 0.56 | 5.8 0.67 | 7.1 0.83 | 8.6 0.99 | 10 1.2 | 14 1.7 | 17 2 | 21 2.5 | 26 3 | 29 3.3 | 34 4 | 43 5 | 51 5.9 |
| | Startup | 2.7 0.31 | 3.2 0.37 | 4.4 0.51 | 5.3 0.61 | 6.6 0.77 | 8 0.92 | 11 1.3 | 13 1.5 | 16 1.8 | 20 2.3 | 24 2.8 | 29 3.3 | 40 4.6 | 48 5.5 | 60 6.9 | 72 8.3 | 80 9.2 | 87 10 | 87 10 | 87 10 |
| SC560-501WU / 5GU□RAA | 1200r/min | 6.9 0.8 | 8.3 0.95 | 12 1.3 | 14 1.6 | 17 2 | 21 2.4 | 29 3.3 | 35 4 | 41 4.8 | 58 6.6 | 61 7 | 73 8.4 | 102 12 | 122 14 | 152 18 | 174 20 | 174 20 | 174 20 | 174 20 | 174 20 |
| | 90r/min | 1.7 0.19 | 2 0.23 | 2.8 0.32 | 3.4 0.39 | 4.2 0.48 | 5 0.58 | 7 0.81 | 8.4 0.97 | 10 1.2 | 14 1.6 | 15 1.7 | 18 2.1 | 25 2.9 | 30 3.4 | 37 4.3 | 45 5.1 | 50 5.7 | 50 5.7 | 62 7.1 | 74 8.6 |
| | Startup | 5.5 0.63 | 6.6 0.76 | 9.1 1.1 | 11 1.3 | 14 1.6 | 16 1.9 | 23 2.6 | 27 3.2 | 33 3.8 | 46 5.3 | 49 5.7 | 59 6.8 | 82 9.5 | 98 11 | 123 14 | 148 17 | 164 19 | 164 19 | 174 20 | 174 20 |

Speed Control Motors SC Series Reversible Type

Hollow shaft (All output shafts rotate opposite to the direction of motor shaft rotation.)

Unit = Upper values:lb-in/Lower values:N-m

| Model \ Gear Ratio | | 3.6 | 6 | 9 | 15 | 18 | 30 | 36 | 60 | 90 | 120 | 180 |
|---------------------------------|-----------|-------------|-------------|-------------|-------------|------------|-----------|-----------|-----------|-----------|-----------|-----------|
| SC425-41 1WU / 4GN□RH | 1200r/min | 2.6 0.3 | 4.3 0.49 | 8 0.92 | 16 1.8 | 19 2.2 | 32 3.7 | 38 4.4 | 64 7.4 | 69 8 | 69 8 | 69 8 |
| | 90r/min | 1.2 0.14 | 2 0.23 | 3.7 0.43 | 7.4 0.86 | 8.9 1 | 15 1.7 | 18 2.1 | 30 3.4 | 45 5.1 | 59 6.8 | 69 8 |
| | Startup | 1.4 0.16 | 2.3 0.26 | 4.3 0.5 | 7.7 0.89 | 9.3 1.1 | 15 1.8 | 19 2.1 | 31 3.6 | 46 5.3 | 62 7.1 | 69 8 |
| SC540-41 1WU / 5GN□RH | 1200r/min | 5 0.58 | 8.3 0.96 | 17 2 | 28 3.3 | 34 3.9 | 50 5.8 | 60 6.9 | 87 10 | 87 10 | 87 10 | 87 10 |
| | 90r/min | 2 0.23 | 3.4 0.39 | 6.9 0.8 | 12 1.3 | 14 1.6 | 20 2.3 | 24 2.8 | 41 4.7 | 61 7 | 81 9.4 | 87 10 |
| | Startup | 3.3 0.38 | 5.5 0.63 | 9.9 1.1 | 16 1.9 | 20 2.3 | 30 3.4 | 35 4.1 | 59 6.8 | 87 10 | 87 10 | 87 10 |
| SC560-51 1WU / 5GU□RH | 1200r/min | 6.2 0.72 | 10 1.2 | 21 2.4 | 35 4.1 | 42 4.9 | 62 7.2 | 75 8.6 | 125 14 | 174 20 | 174 20 | 174 20 |
| | 90r/min | 1.9 0.22 | 3.1 0.36 | 6.4 0.73 | 11 1.2 | 13 1.5 | 19 2.2 | 23 2.6 | 38 4.3 | 56 6.5 | 63 7.2 | 94 11 |
| | Startup | 5.6 0.65 | 9.4 1.1 | 17 1.9 | 28 3.2 | 34 3.9 | 51 5.8 | 61 7 | 101 12 | 152 17 | 169 19 | 174 20 |

Solid shaft (All output shafts rotate opposite to the direction of motor shaft rotation.)

Unit = Upper values:lb-in/Lower values:N-m

| Model \ Gear Ratio | | 3.6 | 6 | 9 | 15 | 18 | 30 | 36 | 60 | 90 | 120 | 180 |
|----------------------------------|-----------|-------------|-------------|-------------|-------------|-------------|-----------|-----------|-----------|-----------|-----------|---------|
| SC425-41 1WU / 4GN□RAA | 1200r/min | 3.2 0.37 | 5.3 0.62 | 8 0.92 | 16 1.8 | 19 2.2 | 32 3.7 | 38 4.4 | 64 7.4 | 69 8 | 69 8 | 69 8 |
| | 90r/min | 1.5 0.17 | 2.5 0.29 | 3.7 0.43 | 7.4 0.86 | 8.9 1 | 15 1.7 | 18 2.1 | 30 3.4 | 45 5.1 | 59 6.8 | 69 8 |
| | Startup | 1.7 0.2 | 2.9 0.33 | 4.3 0.5 | 7 0.81 | 8.4 0.97 | 14 1.6 | 17 1.9 | 28 3.2 | 42 4.9 | 56 6.5 | 69 8 |

Unit = Upper values : lb-in/Lower values : N-m

| Model \ Gear Ratio | | 3 | 3.6 | 5 | 6 | 7.5 | 9 | 12.5 | 15 | 18 | 25 | 30 | 36 | 50 | 60 | 75 | 90 | 100 | 120 | 150 | 180 |
|----------------------------------|-----------|-------------|-------------|-------------|-------------|-------------|-------------|------------|-----------|-----------|-----------|-----------|-----------|-----------|-----------|-----------|-----------|-----------|-----------|-----------|-----------|
| SC540-41 1WU / 5GN□RAA | 1200r/min | 5.7 0.65 | 6.8 0.78 | 9.4 1.1 | 11 1.3 | 14 1.6 | 17 2 | 24 2.7 | 28 3.3 | 34 3.9 | 42 4.8 | 50 5.8 | 60 6.9 | 83 9.6 | 87 10 | 87 10 | 87 10 | 87 10 | 87 10 | 87 10 | 87 10 |
| | 90r/min | 2.3 0.27 | 2.8 0.32 | 3.8 0.44 | 4.6 0.53 | 5.8 0.66 | 6.9 0.8 | 9.6 1.1 | 12 1.3 | 14 1.6 | 17 2 | 20 2.3 | 24 2.8 | 34 3.9 | 41 4.7 | 51 5.9 | 61 7 | 68 7.8 | 81 9.4 | 87 10 | 87 10 |
| | Startup | 3.3 0.38 | 3.9 0.45 | 5.5 0.63 | 6.6 0.76 | 8.2 0.95 | 9.9 1.1 | 14 1.6 | 16 1.9 | 20 2.3 | 25 2.8 | 30 3.4 | 35 4.1 | 49 5.7 | 59 6.8 | 74 8.5 | 87 10 | 87 10 | 87 10 | 87 10 | 87 10 |
| SC560-51 1WU / 5GU□RAA | 1200r/min | 7.1 0.82 | 8.5 0.98 | 12 1.4 | 14 1.6 | 18 2 | 21 2.4 | 29 3.4 | 35 4.1 | 42 4.9 | 59 6.8 | 62 7.2 | 75 8.6 | 104 12 | 125 14 | 156 18 | 174 20 | 174 20 | 174 20 | 174 20 | 174 20 |
| | 90r/min | 2.1 0.24 | 2.6 0.29 | 3.5 0.41 | 4.3 0.49 | 5.3 0.61 | 6.4 0.73 | 8.9 1 | 11 1.2 | 13 1.5 | 18 2 | 19 2.2 | 23 2.6 | 31 3.6 | 38 4.3 | 47 5.4 | 56 6.5 | 63 7.2 | 72 7.2 | 78 9 | 94 11 |
| | Startup | 5.6 0.65 | 6.8 0.78 | 9.4 1.1 | 11 1.3 | 14 1.6 | 17 1.9 | 23 2.7 | 28 3.2 | 34 3.9 | 47 5.4 | 51 5.8 | 61 7 | 84 9.7 | 101 12 | 127 15 | 152 17 | 169 19 | 169 19 | 174 20 | 174 20 |

■ Dimensions Scale 1/4, Unit=inch (mm)

● **4GN** □RH Weight: 3.5 lb. (1.6 kg)

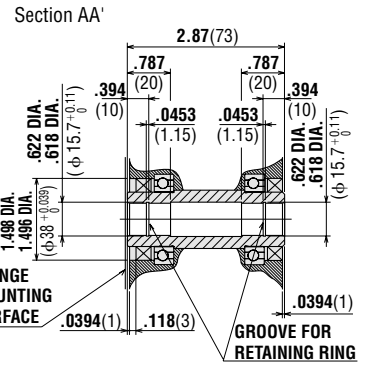
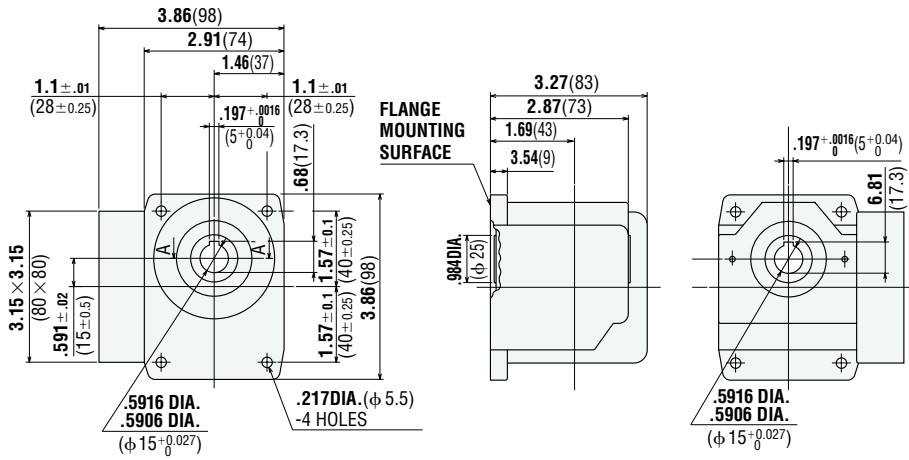

● **Key** Scale 1/2, Unit=inch (mm)

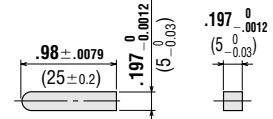

● **5GN** □RH Weight : 4.4 lb. (2.0 kg)

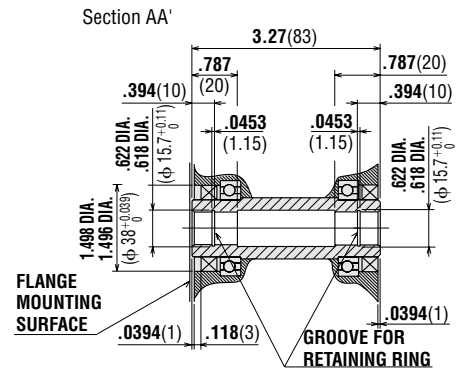
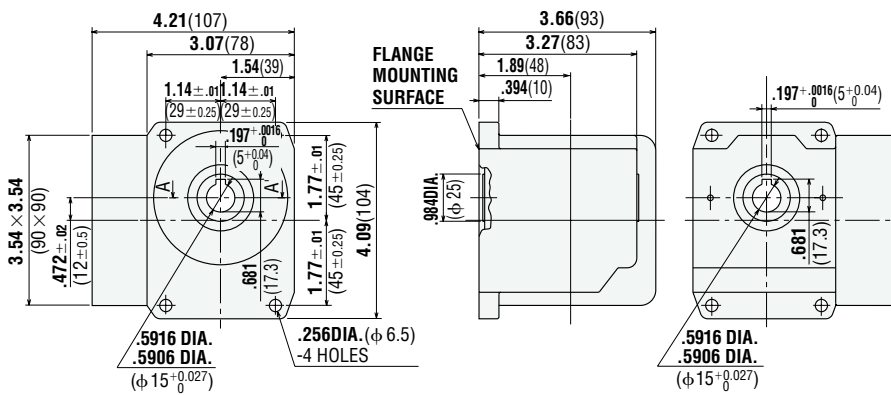

● **Key** Scale 1/2, Unit=inch (mm)

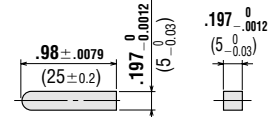

● **5GU** □RH Weight : 5.5 lb. (2.5 kg)

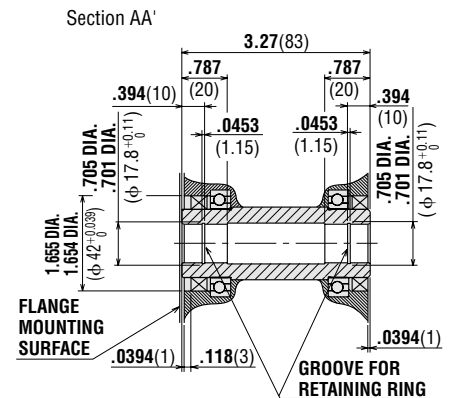
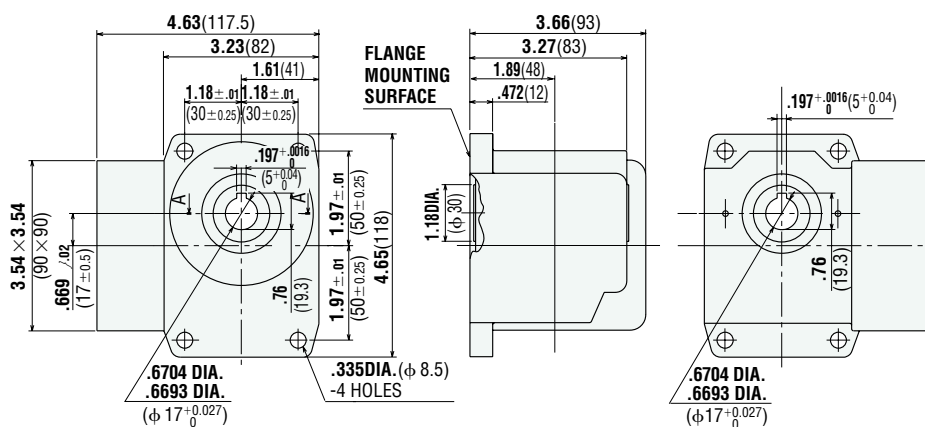

● **Key** Scale 1/2, Unit=inch (mm)

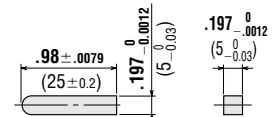

● **4GN** □ **RAA** Weight : 3.5lb. (1.6kg)

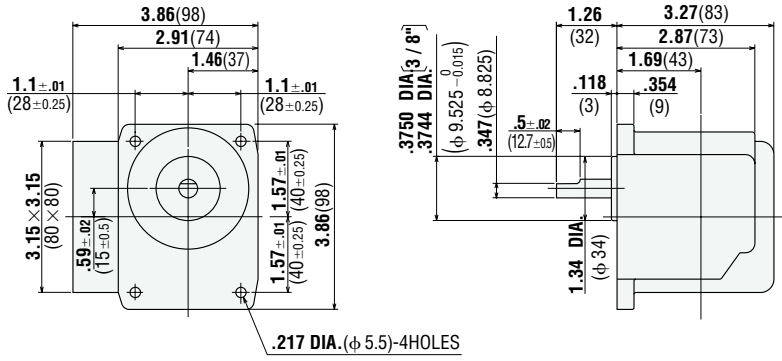

● **5GN** □ **RAA** Weight : 4.4lb. (2.0kg)

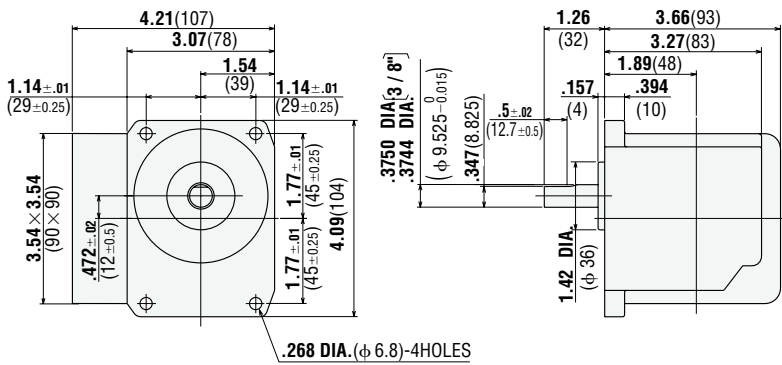

● **5GU** □ **RAA** Weight : 5.5lb. (2.5kg)

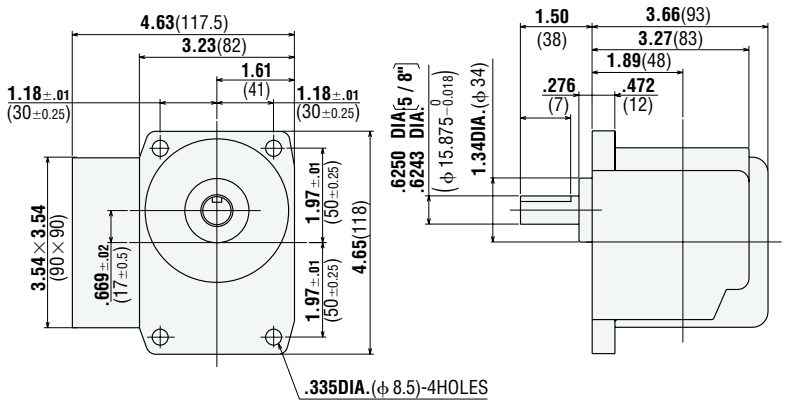

● **Key and Key Slot** Scale 1/2, Unit = inch (mm)

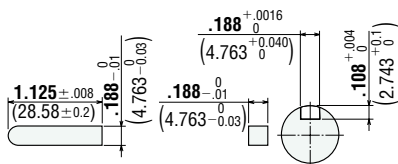

● Dimensions of gearhead mount

Allow at least 0.31inch (8mm) for the thickness of the mounting plate and use screws of appropriate length.

● Cross Section Unit = inch (mm)

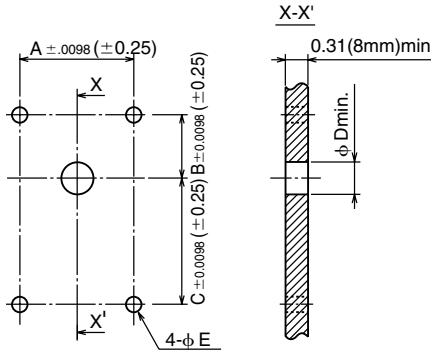

| Unit = inch (mm) | | | | | | |
|------------------|-------------------------|-----------|-----------|-----------|-----------------------|------------------------|
| Type | Model | A | B | C | ϕ D | ϕ E |
| Hollow shaft | 4GN □ RH | 2.20 (56) | 0.98 (25) | 2.17 (55) | 0.59DIA. (ϕ 15) | 0.22DIA. (ϕ 5.5) |
| | 5GN □ RH | 2.28 (58) | 1.30 (33) | 2.24 (57) | 0.59DIA. (ϕ 15) | 0.26DIA. (ϕ 6.5) |
| | 5GU □ RH | 2.36 (60) | 1.30 (33) | 2.64 (67) | 0.67DIA. (ϕ 17) | 0.33DIA. (ϕ 8.5) |
| Solid shaft | 4GN □ RAA | 2.20 (56) | 0.98 (25) | 2.17 (55) | 1.38DIA. (ϕ 35) | 0.22DIA. (ϕ 5.5) |
| | 5GN □ RAA | 2.28 (58) | 1.30 (33) | 2.24 (57) | 1.46DIA. (ϕ 37) | 0.27DIA. (ϕ 6.8) |
| | 5GU □ RAA | 2.36 (60) | 1.30 (33) | 2.64 (67) | 1.38DIA. (ϕ 35) | 0.33DIA. (ϕ 8.5) |

Enter the gear ratio in the box(□) within the model name.

● Example of Mounting the Load

The diagrams below show how to mount loads depending on the shape of the shaft. Use the key provided with the product by fastening it to the shaft. Apply a coating of molybdenum disulfide or similar grease to the inner diameter of the load shaft to prevent binding. Recommended load shaft dimensions are shown below.

| Unit = inch (mm) | | |
|------------------------|---|---|
| Model | Inner diameter of hollow-shaft | Recommended load shaft diameter |
| 4GN □ RH | 0.5906DIA. $^{+0.0011}_0$ (ϕ 15 $^{+0.027}_0$) | 0.5906DIA. $^{0}_{-0.0007}$ (ϕ 15 $^{0}_{-0.018}$) |
| 5GN □ RH | 0.5906DIA. $^{+0.0011}_0$ (ϕ 15 $^{+0.027}_0$) | 0.5906DIA. $^{0}_{-0.0007}$ (ϕ 15 $^{0}_{-0.018}$) |
| 5GU □ RH | 0.6693DIA. $^{+0.0011}_0$ (ϕ 17 $^{+0.027}_0$) | 0.6693DIA. $^{0}_{-0.0007}$ (ϕ 17 $^{0}_{-0.018}$) |

Enter the gear ratio in the box(□) within the model name.

Stepped-down shafts

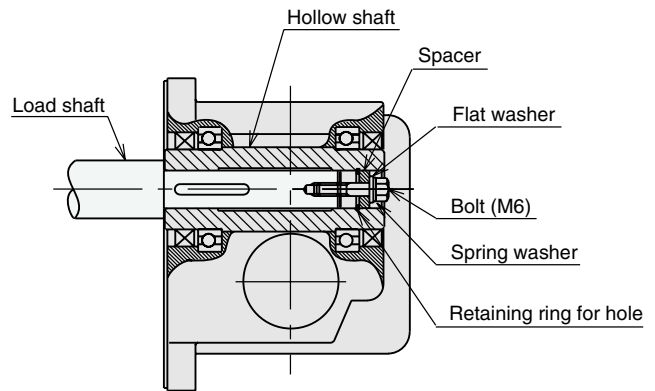

Straight load shafts

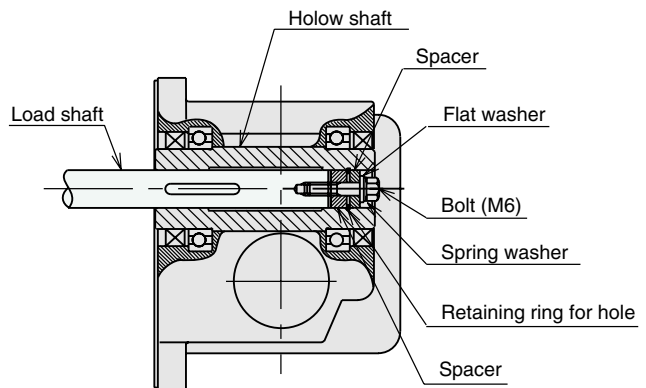

Note: If the bolt extends out more than 0.157inch (4mm) from the end of the hollow shaft, no safety cover can be installed. (**RH** model hollow shaft gearheads include safety covers.)

ORIENTAL MOTOR GENERAL CATALOG



Linear Heads

FeaturesA-228
 General Specifications.....A-232
 Product SpecificationsA-233

Linear Heads



(Motors are sold separately.)

■ Features

Linear heads are linear motion rack-and-pinion units for use with our standard AC motors.

- Depending on the type of motor coupled directly to the linear head, various types of movements are possible.
- A wide range of products are available.
- Motors for direct coupling to the linear heads are sold separately.
- Decimal gearheads which reduce the basic speed by 10:1 are available.

■ Product Number Code

4 L B 45 N -3

Stroke Length (1~7)

Example 3: 11.81 inch (300mm)

Type of Gear

N: GN type (for use with GN type pinion shaft motor)

U: GU type (for use with GU type pinion shaft motor)

Speed Indication: Indicating theoretical rack speed. This speed is calculated using the synchronous speed of the motor used (1800r/min). See the products' specifications for available code.

Direction of Rack Travel

F: Vertical stroke type (Rack travels vertically to mounting face)

B: Horizontal stroke type (Rack travels horizontally to mounting face)

L: Linear Head

Frame size

0: 1.67inch sq. (42mm sq.)

2: 2.36inch sq. (60mm sq.)

4: 3.15inch sq. (80mm sq.)

5: 3.54inch sq. (90mm sq.)

■ Example Applications

L-line provides a linear drive mechanism in the form of a unit. It can be used in a variety of applications, as shown in the figures, for simpler mechanism design and easier wiring.

1. Pressing operation

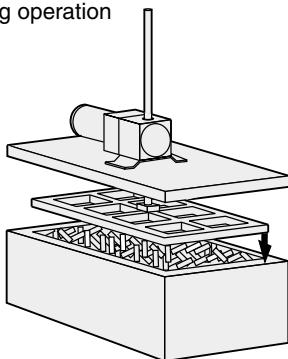

2. Reversing operation

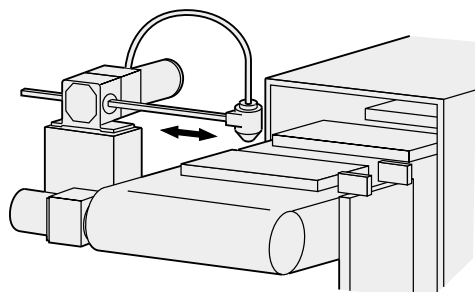

3. Traveling operation

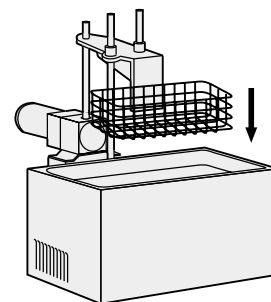

Construction

The linear heads use reduction gears to reduce motor speed and increase motor torque, while the rack-and-pinion converts rotational motion into linear motion. The rack-and-pinion mechanism is a reliable and low cost method for converting rotational motion into linear motion.

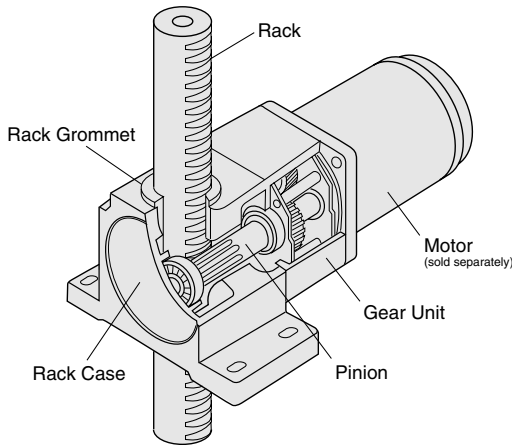

The direction of rack movement is determined by the direction of motor rotation.

When the rack reaches either end, it is necessary to reverse the direction of rack movement by changing the direction of motor rotation. Since the product does not have an automatic stop/reverse mechanism, it is necessary to attach limit switches or sensors to change the motor rotation.

Motor Unit

The ideal way to change the direction of rack movement instantaneously is to use a reversible motor.

Rack

Solid-drawn S45C steel is gear-cut and given a nitride finish to reduce sliding friction and provide rust-resistance.

Rack Grommet

The rack is supported by two grommets made by an oilless metal.

If the end of the rack should advance into the rack case and the rack is supported by only one grommet, it might cause the mechanism to malfunction. The rack movement should always be reversed before the edge of the rack reaches the rack grommet.

System Composition

Linear Heads

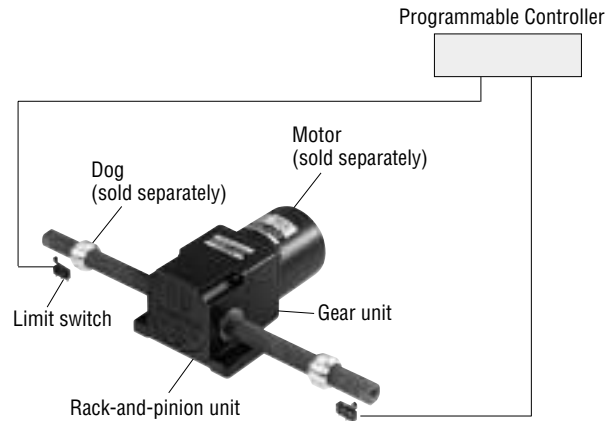

The linear heads come with a rack-and-pinion unit and a reduction gear unit. Motors and dogs are sold separately. Linear heads may be combined with any standard AC motors. Any limit switches available on the market can be used. Three rack speeds are available for a given frame size, by changing on the speed reduction ratio. The rack movement is controlled using a brake pack, programmable controller or relays.

Rack Play

The rack of the linear head is supported at two places by oilless metal grommets in the rack case. Because the rack passes through the inside of the grommets, a slight gap has been left between the grommet and the rack. Therefore, the rack is subject to play as shown in the figure below.

| | |
|------------------|-------------------------|
| Direction A or B | 0.079 inch (2mm) max. |
| Direction C | 0.020 inch (0.5mm) max. |

Play in directions A and B has been measured at a point from the case surface. Since the rack is round-shaped, play in the D direction is large. The rack play indicates an initial value which will increase during operation. If the rack play becomes problem, install an external guide.

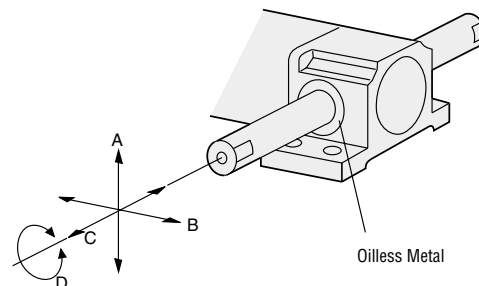

■ "Characteristics" of Linear Motors and Linear Heads

Rack moving speed, thrust force and holding force are important factors to consider when selecting linear motors or linear heads.

● Rack moving speed

The rack speed for the linear motor is given in the table of specifications for each product. Rack speed is expressed as "basic speed".

The basic speed is calculated on the basis of the synchronous speed of the motor (i.e. 1800r/min at 60Hz). In actuality, however, the speed of the motor varies with the load.

The basic speed of a linear head can be calculated from the motor speed, by using the following equation.

$$V = N_s \times \frac{1}{60} \times \frac{1}{i} \times \pi D_p$$

V : Rack moving speed [inch/sec.]

N_s : Speed of motor used [r/min]

i : Ratio of gear unit on the linear head (see table below)

D_p : Pinion pitch circumference [inch] (see table below)

● Thrust force

In linear heads, the following equation is used to calculate the thrust force from the torque generated by the motor used.

$$W = T_m \times i \times \eta_1 \times \frac{2}{D_p} \times \eta_2$$

W : Thrust force [lb.]

T_m : Torque of motor used [lb.]

i : Ratio of gear unit on the linear head (see table below)

η_1 : Transmission efficiency as determined by the gear ratio (see table below)

D_p : Pinion pitch circumference [inch] (see table below)

η_2 : Transmission efficiency of rack and pinion (=0.9)

| Linear Head Model | Gear Ratio i | Transmission efficiency η_1 | Pinion Pitch Diameter D_p inch.(mm) |
|----------------------|-------------------|-------------------------------------|--|
| 0LB (F) 20N-□ | 30 | 0.66 | 0.295 (7.5) |
| 0LB (F) 10N-□ | 50 | 0.66 | |
| 0LB (F) 5N-□ | 100 | 0.59 | |
| 2LB (F) 50N-□ | 17.68 | 0.73 | 0.472 (12) |
| 2LB (F) 25N-□ | 35.36 | 0.66 | |
| 2LB (F) 10N-□ | 86.91 | 0.59 | |
| 4LB (F) 45N-□ | 36 | 0.73 | 0.837 (21.25) |
| 4LB (F) 20N-□ | 75 | 0.66 | |
| 4LB (F) 10N-□ | 150 | 0.66 | |
| 5LB (F) 45N-□ | 36 | 0.66 | 0.945 (24) |
| 5LB (F) 20N-□ | 90 | 0.59 | |
| 5LB (F) 10N-□ | 180 | 0.59 | |
| 5LB (F) 45U-□ | 36 | 0.66 | 0.945 (24) |
| 5LB (F) 20U-□ | 90 | 0.59 | |
| 5LB (F) 10U-□ | 180 | 0.59 | |

The value of the load is determined using the equation assumes that the rack is moving horizontally. If it is moving vertically, subtract the mass of the rack from the value contained in the characteristics table.

● Holding torque

The following equation is used to calculate the holding force of the linear head when connected to a motor.

$$F_B = T_B \times i \times \frac{2}{D_p}$$

F_B : Holding force [lb.]

T_B : Holding torque of motor used [lb.]

i : Ratio of gear unit on the linear head (see table above)

D_p : Pinion pitch circumference [inch] (see table above)

The holding force is the value when operating the rack in a horizontal direction. The holding load that can be driven when operating the mechanism vertically is the maximum thrust force less the rack weight.

■ Operation

● Controlling motion of rack

Linearheads are essentially alike in that the rack is moved through the control of a motor.

Blocking the operation at the end of the rack in order to stop the motor will not only apply an excessive torque to the gears, but will also result in an inertial shock, reducing the life of the gears substantially. Take special care never to stop the motor in this way.

● Use at less than the maximum permissible thrust force

The thrust force of linear heads varies with the basic speed (determined by the gear ratio of the gearhead), with thrust force becoming larger at lower speeds (greater gear ratio). This increase in thrust force is limited, by the mechanical strength of gears or shaft. Permissible thrust force is determined by taking into consideration the motor torque and the mechanical strength of the shafts and gears, then adding a safety margin. If a load greater than this value is applied, or rack movement is locked for a long time, it is likely to result in damage to the rack-and-pinion or gear unit.

● Maintain overhung load within permissible level

The amount of overhung load that can be applied to the rack is determined by the total load on the rack bearing. Operate rack at loads within the limits given in the following table.

unit=lb. (kg)

| Rack Stroke inch. (mm) | 2L type | 4L type | 5L-N type 5L-U type |
|---------------------------|------------|-----------|------------------------|
| 3.9 (100) | 12.1 (5.5) | 26.4 (12) | 28.6 (13) |
| 7.9 (200) | 8.8 (4) | 19.8 (9) | 22 (10) |
| 11.8 (300) | 6.6 (3) | 15.4 (7) | 17.6 (8) |
| 15.7 (400) | 5.5 (2.5) | 13.2 (6) | 13.2 (6) |
| 19.7 (500) | 4.4 (2) | 11 (5) | 11 (5) |
| 23.6 (600) | — | 8.8 (4) | 11 (5) |
| 27.6 (700) | — | 8.8 (4) | 8.8 (4) |

The table shows the cases in which the entire rack stroke can be used. When the actual usable range is shorter than the rack stroke, a load up to the permissible value for that length stroke can be applied.

● Rack Lubrication

Some sort of lubricating agent is necessary to prevent friction when the rack passes through the rack grommet. The surface of the rack and any gears that mesh with the pinion should always be kept lubricated. In our products, since the rack case is filled with a lubrication agent, there is no need to lubricate the rack case. However, ensure that the surface of the rack or gear teeth do not become dry, as operating in this condition will shorten the product's life.

● Use an electromagnetic brake motor for vertical operation

Operation using vertical motion, such as in elevators, often requires that the load be held in position at mid-stroke. For such applications, a model equipped with an electromagnetic brake, which offers high holding power, is recommended. The electromagnetic brake motor has the strongest holding power of all standard AC motors.

These electromagnetic brakes are power off brakes that are engaged in the event of a power failure.

Glossary

● Installation of the load to the end of the rack

When connecting the load using the tapped hole on the end of the rack, so that a rotational force is not applied to the rack. Hold the rack with a wrench while tightening the screw.

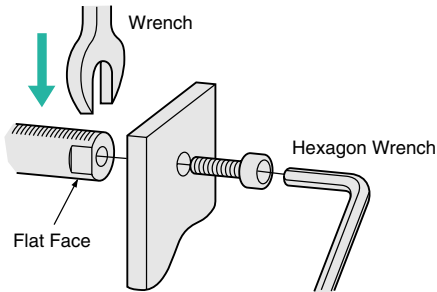

● Connecting Linear Heads

As the figure below shows, a linear head is connected to a motor using the recessed areas on each unit as guides. Gently slide the linear head from side to side without forcing the pinion shaft against the plate on the linear head or against the gear itself.

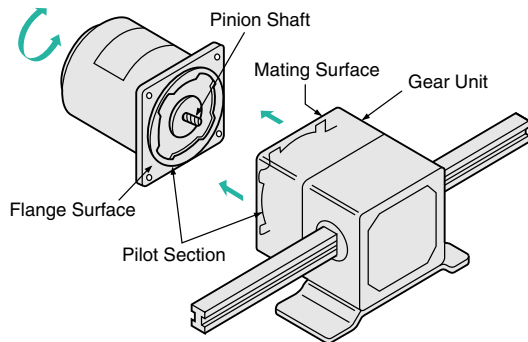

● Note:

Attempting to put a motor and linear head together by force can result in damage to the linear head.

Linear Heads

● Permissible Thrust Force

This is the maximum thrust force that can be used when the motor is operating. For example, if there is a thrust force of 154lb. (70kg), objects up to a weight of 154lb. (70kg) can be lifted.

● Holding Force

This is the force required to hold the rack at the position where it has stopped. If the mechanism is being used for vertical movement, this force must be able to hold a load fastened to the end of the rack to prevent it from falling.

● Basic Speed

This is the rack speed that is given as the basis for the selection of linear heads. The values indicated are calculated on the basis of the synchronous speed (i.e. 1800r/min at 60Hz) of the motor. However, the actual speed of the motor fluctuates according to the size of the load and can range from 2% to 20% less than the basic speed.

● Stroke

This is the distance that the rack can move. The full length of the rack is this distance plus the width of the rack case.

● Maximum Overhung Load

This is the load that can be applied to the rack in a direction perpendicular to the rack axis. If a load is applied continuously to the end of the rack, then the weight of that load will be applied to the rack as an overhung load.

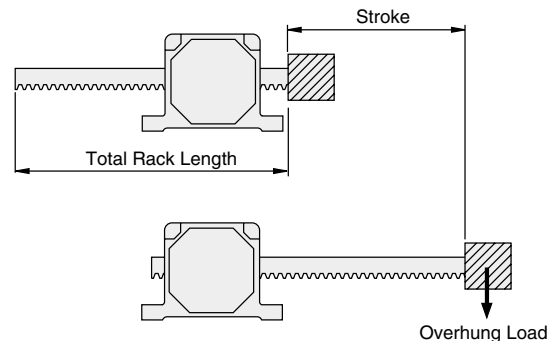

● Dog

The function of dogs is to trip limit switches and sensors. Dogs are attached to the rack to set the position where the rack should stop.

● Rack

A gearcut rod is made of S45C or equivalent grade of steel. Racks for linear motors are specially designed and machined, and have special cross sections; those for linear heads have round cross sections.

■ Specifications

| Type of Linear Head | Basic Speed | | Max. Permissible Thrust Force | | Stroke Length in. (mm) | Page |
|---------------------|-------------|------|-------------------------------|-----|---|-------|
| | in./s | mm/s | lbs. | kg | | |
| 0L type | 0.94 | 24 | 8.4 | 3.8 | 3.9, 7.9 (100, 200) | A-233 |
| | 0.47 | 12 | 14 | 6.3 | | |
| | 0.24 | 6 | 22 | 10 | | |
| 2L type | 2.4 | 60 | 19 | 8.7 | 3.9, 7.9, 11.8, 15.7, 19.7 (100, 200, 300, 400, 500) | A-234 |
| | 1.2 | 30 | 33 | 15 | | |
| | 0.47 | 12 | 44 | 20 | | |
| 4L type | 2.1 | 54 | 68 | 31 | 3.9, 7.9, 11.8, 15.7, 19.7, 23.6, 27.6 (100, 200, 300, 400, 500, 600, 700) | A-238 |
| | 0.94 | 24 | 128 | 58 | | |
| | 0.47 | 12 | 154 | 70 | | |
| 5L-N type | 2.1 | 54 | 229 | 104 | 3.9, 7.9, 11.8, 15.7, 19.7, 23.6, 27.6 (100, 200, 300, 400, 500, 600, 700) | A-243 |
| | 0.94 | 24 | 308 | 140 | | |
| | 0.47 | 12 | 308 | 140 | | |
| 5L-U type | 2.1 | 54 | 229 | 104 | 3.9, 7.9, 11.8, 15.7, 19.7, 23.6, 27.6 (100, 200, 300, 400, 500, 600, 700) | A-248 |
| | 0.94 | 24 | 308 | 140 | | |
| | 0.47 | 12 | 308 | 104 | | |

- Basic speed is based on the synchronous speed (1800r/min at 60Hz). The actual speed varies with the load or power supply frequency.
- The permissible thrust force is determined by the strength of the linear head. Just as when connecting a gearhead to the motor, increasing the gear ratio generates greater thrust force, but the motor should always be operated below the maximum permissible thrust force.
- The thrust force is the value when operating the rack in a horizontal direction.
- The thrust force given is for when combined with a reversible motor.

■ Applications and Recommended Motor Combinations

| Application | Applicable Motor | 0L type | 2L type | 4L type | 5L-N type | 5L-U type |
|----------------------|------------------------------|-------------------|---|---|---|--|
| Constant Speed | Reversible Motors | ORK1GN-AUL | 2RK6GN-AW(T)U 2RK6GN-CW(T)E 2RK6GN-AUL | 4RK25GN-AW(T)U 4RK25GN-CW(T)E 4RK25GN-AUL | 5RK40GN-AW(T)U 5RK40GN-CW(T)E 5RK40GN-AUL | 5RK60GU-AW(T)U 5RK60GU-CW(T)E 5RK60GU-AUL 5RK90GU-AW(T)U 5RK90GU-CW(T)E 5RK90GU-AUL |
| | Synchronous Motors | — | 2SK4GN-AUL | 4SK15GN-AUL | 5SK25GN-AUL | — |
| Position Holding | Electromagnetic Brake Motors | — | 2RK6GN-AWMU 2RK6GN-CWME 2RK6GN-AMUL | 4RK25GN-AWMU 4RK25GN-CWME 4IK25GN-SWM 4RK25GN-AMUL | 5RK40GN-AWMU 5RK40GN-CWME 5IK40GN-SWM 5RK40GN-AMUL | 5RK60GU-AWMU 5RK60GU-CWME 5IK60GU-SWM 5RK60GU-AMUL 5RK90GU-AWMU 5RK90GU-CWME 5IK90GU-SWM 5RK90GU-AMUL |
| Thrust Linear Motion | Torque Motors | — | — | 4TK10GN-AUL | 5TK20GN-AUL | — |

- The torque motor does not have a built-in friction brake. Be sure that the torque motor has no holding brake force even when stopping during vertical operations. When operating a torque motor at high-speed, ensure that the rack does not hit an object and stop, since this can add excessive torque to the linear head and subject it to inertial shock which can significantly shorten its life.

OL type Linear Head

Max. Thrust Force

22lb.(10kg)



Specifications

| Basic Speed | Model | Rack Stroke |
|-------------------|--|--------------------------------------|
| 0.24in/s (6mm/s) | OLB5N-1, OLB5N-2 OLF5N-1, OLF5N-2 | 3.9 inch (100mm) 7.9 inch (200mm) |
| 0.47in/s (12mm/s) | OLB10N-1, OLB10N-2 OLF10N-1, OLF10N-2 | |
| 0.94in/s (24mm/s) | OLB20N-1, OLB20N-2 OLF20N-1, OLF20N-2 | |

- Basic speed figures are based on synchronous speed. The actual speed varies with the load or frequency of the power source.
- The box (□) represents the code for stroke length.

Direction of Rack Movement

The direction of rack movement is determined by the direction of motor rotation.

| Model | Motor Rotation | |
|-----------------|----------------|-------|
| | CW | CCW |
| OLB10N-□ | Right | Left |
| OLB20N-□ | Right | Left |
| OLF10N-□ | Up | Down |
| OLF20N-□ | Up | Down |
| OLB5N-□ | Left | Right |
| OLF5N-□ | Down | Up |

- Trip dogs and limit switches are necessary to stop or reverse the rack movement.
- Direction of rack movement is as viewed from the front side of the linear head.

Dimensions

Scale 1/4, Unit = inch (mm)

B type (horizontal)

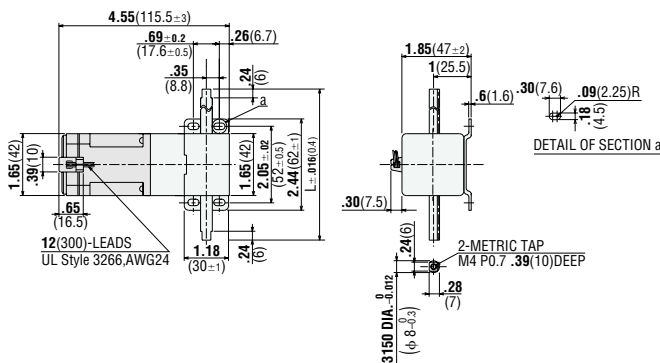

F type (vertical)

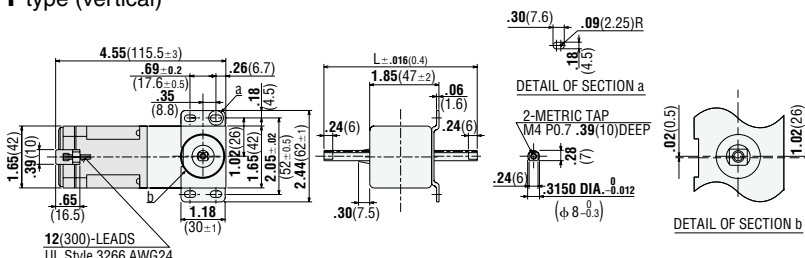

Max. Permissible Overhung Load

| Stroke | Max. Permissible Overhung Load |
|------------------|--------------------------------|
| 3.9 inch (100mm) | 2.6lb. (1.2kg) |
| 7.9 inch (200mm) | 1.8lb. (0.8kg) |

Motor Combination

| Motor type | Motor Model | Page |
|------------------|-------------------|------|
| Reversible Motor | ORK1GN-AUL | A-78 |

- Overrun
- Overrun is the value when operating the rack in a horizontal direction.

| Model | Overrun inch (mm) |
|-----------------|-------------------|
| OL□5N-□ | 0.06 (1.4) |
| OL□10N-□ | 0.11 (2.8) |
| OL□20N-□ | 0.19 (4.7) |

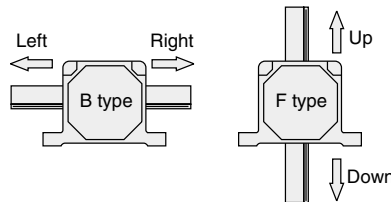

Weight, Stroke Length and Rack Length

| Model | Stroke inch (mm) | Total Length L inch (mm) | Weight(Mass) lb. (kg) | Rack Weight(Mass) lb. (kg) |
|----------------|------------------|--------------------------|-----------------------|----------------------------|
| OLB□N-1 | 3.9 (100) | 6.31 (160.2) | 1.23 (0.56) | 0.11 (0.05) |
| OLF□N-1 | 3.9 (100) | 6.31 (160.2) | 1.23 (0.56) | 0.11 (0.05) |
| OLB□N-2 | 7.9 (200) | 10.26 (260.7) | 1.32 (0.60) | 0.20 (0.09) |
| OLF□N-2 | 7.9 (200) | 10.26 (260.7) | 1.32 (0.60) | 0.20 (0.09) |

2L type Linear Head

Max. Thrust Force

44lb.(20kg)

■ Max. Thrust Force

44 lb. (20 kg). Thrust force varies with basic speed and the motor combined.



■ Specifications

| Basic Speed | Model | Rack Stroke inch (mm) |
|---------------------|------------------|-----------------------|
| 0.47 in/s (12 mm/s) | 2LB10N -□ | 3.9 (100) |
| | 2LF10N -□ | |
| 1.2 in/s (30 mm/s) | 2LB25N -□ | 7.9 (200) |
| | 2LF25N -□ | |
| 2.4 in/s (60 mm/s) | 2LB50N -□ | 15.7 (400) |
| | 2LF50N -□ | |

- Basic speed figures are based on synchronous speed. (60Hz : 1800r/min) The actual speed varies with the load or frequency of the power source.
- The box (□) represents the code for stroke length.

■ Max. Permissible Overhung Load

| Stroke inch (mm) | Max. Permissible Overhung Load lb. (kg) |
|---------------------|--|
| 3.9 (100) | 12.1 (5.5) |
| 7.9 (200) | 8.8 (4) |
| 11.8 (300) | 6.6 (3) |
| 15.7 (400) | 5.5 (2.5) |
| 19.7 (500) | 4.4 (2) |

■ Motor Combination

| Motor type | Motor Model | Page |
|-----------------------------|----------------------|-------|
| Reversible Motor | 2RK6GN-AW(T)U | A-82 |
| | 2RK6GN-CW(T)E | |
| Electromagnetic Brake Motor | 2RK6GN-AWMU | A-182 |
| | 2RK6GN-CWME | |

■ Models

| Rack Stroke inch (mm) | Basic Speed | | |
|--------------------------|-------------------|------------------|------------------|
| | 0.47in/s (12mm/s) | 1.2in/s (30mm/s) | 2.4in/s (60mm/s) |
| 3.9(100) | 2LB10N-1 | 2LB25N-1 | 2LB50N-1 |
| | 2LF10N-1 | 2LF25N-1 | 2LF50N-1 |
| 7.9(200) | 2LB10N-2 | 2LB25N-2 | 2LB50N-2 |
| | 2LF10N-2 | 2LF25N-2 | 2LF50N-2 |
| 11.8(300) | 2LB10N-3 | 2LB25N-3 | 2LB50N-3 |
| | 2LF10N-3 | 2LF25N-3 | 2LF50N-3 |
| 15.7(400) | 2LB10N-4 | 2LB25N-4 | 2LB50N-4 |
| | 2LF10N-4 | 2LF25N-4 | 2LF50N-4 |
| 19.7(500) | 2LB10N-5 | 2LB25N-5 | 2LB50N-5 |
| | 2LF10N-5 | 2LF25N-5 | 2LF50N-5 |

- Longer mounting screws are required if a decimal gearhead is used.

■ Performance Examples with Several Motor Combinations

● Overrun Unit = inch (mm)

| Linear Head | Motor | | |
|-------------|------------|------------|------------|
| | 2LB10N-□ | 2LB25N-□ | 2LB50N-□ |
| 2RK6GN-AWU | 0.10 (2.6) | 0.25 (6.4) | 0.51 (13) |
| 2RK6GN-AWMU | 0.05 (1.3) | 0.13 (3.2) | 0.25 (6.4) |

Overrun at motor shaft is estimated to be 6 revolutions for reversible motors and 3 revolutions for electromagnetic brake motors.

- The maximum thrust load that can be driven when operating the mechanism vertically is the maximum thrust force less the rack weight.
- When operating the mechanism horizontally using a guide or similar device to bear the load, ensure that the load weight is less than the maximum thrust force.

■ Direction of Rack Movement

The direction of rack movement is determined by the direction of motor rotation.

| Model | Motor Rotation | |
|----------|----------------|-------|
| | CW | CCW |
| 2LB10N-□ | Right | Left |
| 2LB50N-□ | Right | Left |
| 2LF10N-□ | Down | Up |
| 2LF50N-□ | Down | Up |
| 2LB25N-□ | Left | Right |
| 2LF25N-□ | Up | Down |

- Direction of rack movement is as viewed from the front side of the linear head.
- A dog mounted on the rack (optional) and limit switch are required to stop or reverse a rack. Dogs are available as optional accessories. Use dogs for stop and reverse operation.

■ Accessories (sold separately)

● Dog

A dog should be mounted on the rack to stop or reverse a rack. For details, see page A-273



● Dimensions Unit = inch (mm)

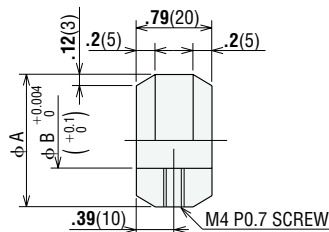

| | Model | A inch (mm) | B inch (mm) |
|-------------------------|--------------|-------------|-------------|
| For 2L type Linear Head | LXD2C | 0.94 (24) | 0.54 (13.8) |

● Reversible Motor (2RK6GN-AWU)

| Item | Model | | |
|----------------------------|-----------|-----------|------------|
| | 2LB10N-□ | 2LB25N-□ | 2LB50N-□ |
| Max. Thrust Force lb. (kg) | 44 (20) | 30.8 (14) | 17.4 (7.9) |
| Holding Force lb. (N) | 15.8 (72) | 6.4 (29) | 3.1 (14) |

- Holding force is provided by the built-in friction brake of the reversible motor. The values given in the table vary depending on the temperature and the time of operation, and thus should only be used as reference.

● Electromagnetic Brake Motor (2RK6GN-AWMU)

| Item | Model | | |
|----------------------------|----------|------------|------------|
| | 2LB10N-□ | 2LB25N-□ | 2LB50N-□ |
| Max. Thrust Force lb. (kg) | 44 (20) | 30.8 (14) | 17.4 (7.9) |
| Holding Force lb. (N) | 44 (200) | 37.4 (170) | 19.4 (88) |

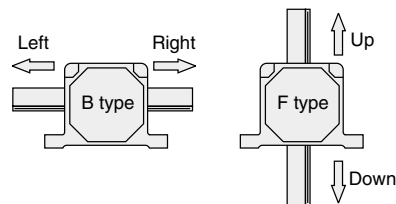

● Rack Cover

Rack covers for rack protection and dustproofing are available. For details, see Page A-256.



■ Dimensions Scale 1/4, Unit = inch (mm)

2LB type (horizontal)

2LB□N-□/2RK6GN-AWU
2RK6GN-CWE
2RK6GN-AUL

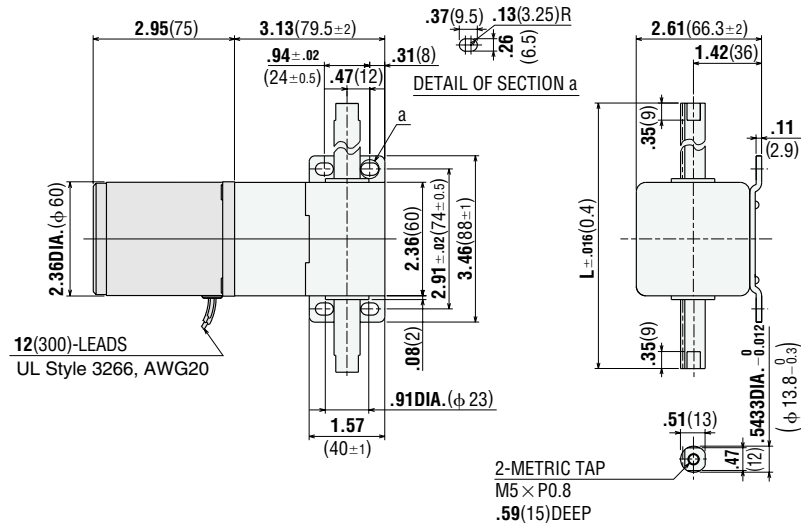

2LB□N-□/2RK6GN-AWTU
2RK6GN-CWTE

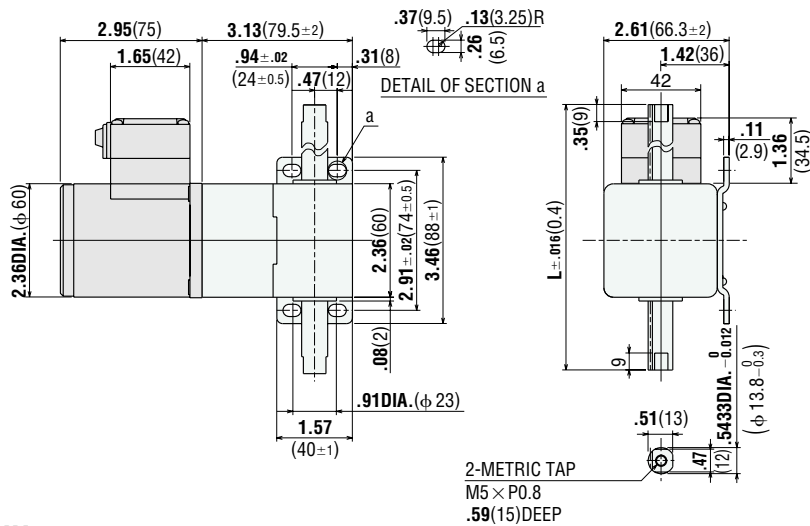

2LB□N-□/2RK6GN-AWMU
2RK6GN-CWME
2RK6GN-AMUL

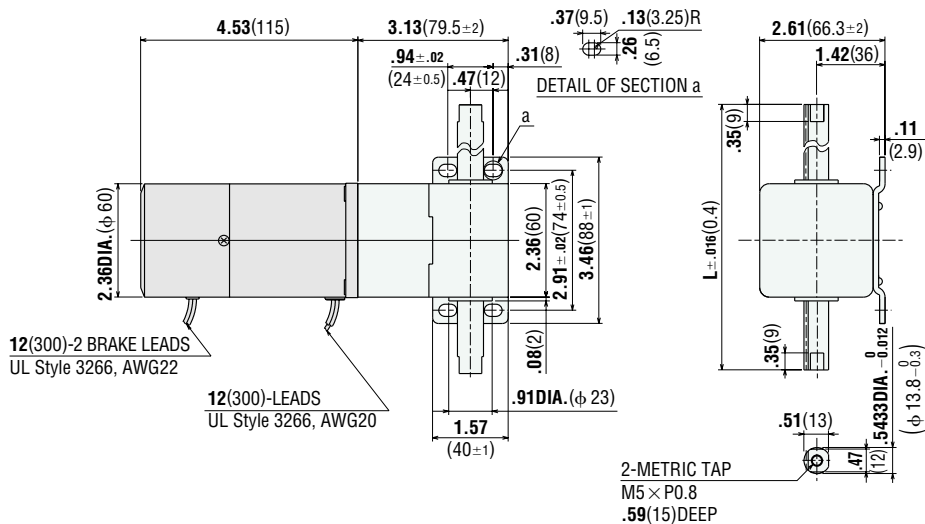

2LF type (vertical)

2LF□N-□/2RK6GN-AWU
2RK6GN-CWE
2RK6GN-AUL

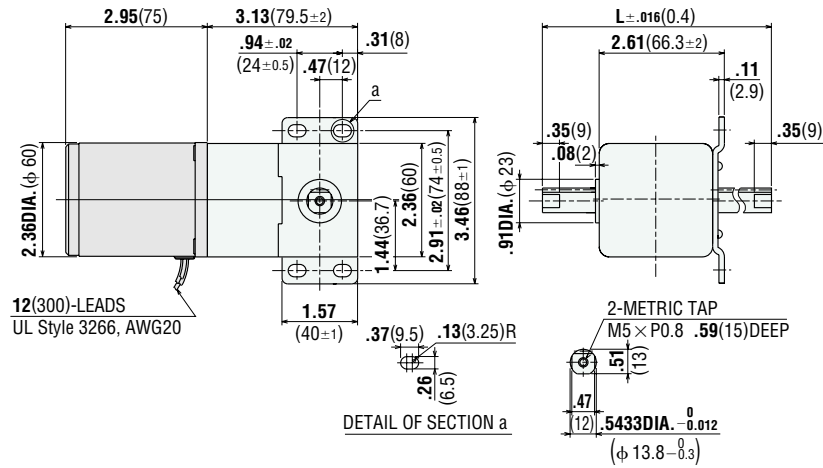

2LF□N-□/2RK6GN-AWTU
2RK6GN-CWTE

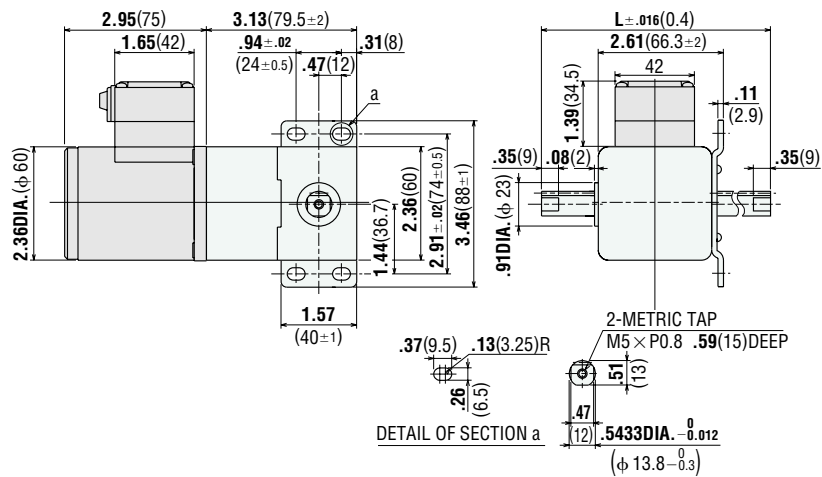

2LF□N-□/2RK6GN-AWMU
2RK6GN-CWME
2RK6GN-AMUL

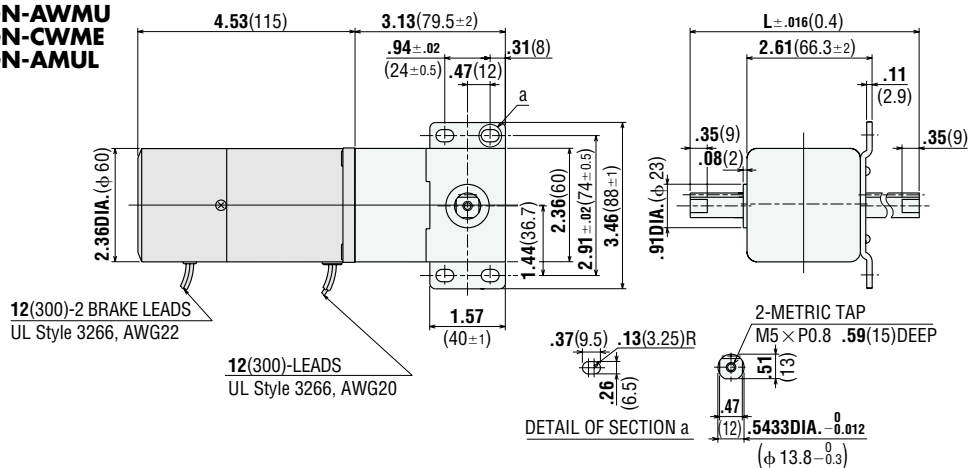

● Weight, Stroke Length and Rack Length

| Model | Stroke | Total Length L | Weight (Mass) | Rack Weight (Mass) |
|------------------|------------|----------------|---------------|--------------------|
| | inch (mm) | inch (mm) | lb. (kg) | lb. (kg) |
| 2LB□N-1, 2LF□N-1 | 3.9 (100) | 6.93 (175.9) | 1.98 (0.9) | 0.44 (0.2) |
| 2LB□N-2, 2LF□N-2 | 7.9 (200) | 10.89 (276.5) | 2.20 (1.0) | 0.66 (0.3) |
| 2LB□N-3, 2LF□N-3 | 11.8 (300) | 14.84 (377.0) | 2.42 (1.1) | 0.88 (0.4) |
| 2LB□N-4, 2LF□N-4 | 15.7 (400) | 18.80 (477.5) | 2.64 (1.2) | 1.10 (0.5) |
| 2LB□N-5, 2LF□N-5 | 19.7 (500) | 22.76 (578.0) | 2.86 (1.3) | 1.32 (0.6) |

4L type Linear Head

Max. Thrust Force

154lb.(70kg)

■ Max. Thrust Force

154lb. (70 kg). Thrust force varies with basic speed and the motor combined.



■ Specifications

| Basic Speed | Model | Rack Stroke inch (mm) |
|---------------------|---|-----------------------|
| 0.47 in/s (12 mm/s) | 4LB10N- <input type="checkbox"/> | 3.9 (100) |
| | 4LF10N- <input type="checkbox"/> | 7.9 (200) |
| 1.2 in/s (30 mm/s) | 4LB20N- <input type="checkbox"/> | 11.8 (300) |
| | 4LF20N- <input type="checkbox"/> | 15.7 (400) |
| 2.4 in/s (60 mm/s) | 4LB45N- <input type="checkbox"/> | 19.7 (500) |
| | 4LF45N- <input type="checkbox"/> | 23.6 (600) |
| | | 27.6 (700) |

- Basic speed figures are based on synchronous speed (60Hz : 1800r/min). The actual speed varies with the load or frequency of the power source.
- The box represents the code for stroke length.

■ Max. Permissible Overhung Load

| Stroke inch (mm) | Max. Permissible Overhung Load lb. (kg) |
|------------------|---|
| 3.9 (100) | 26.4 (12) |
| 7.9 (200) | 19.8 (9) |
| 11.8 (300) | 15.4 (7) |
| 15.7 (400) | 13.2 (6) |
| 19.7 (500) | 11.0 (5) |
| 23.6 (600) | 8.8 (4) |
| 27.6 (700) | 8.8 (4) |

■ Motor Combination

| Motor type | Motor Model | Page |
|-----------------------------|-----------------------|-------|
| Reversible Motor | 4RK25GN-AW(T)U | A-90 |
| | 4RK25GN-CW(T)E | |
| | 4RK25GN-AWMU | |
| Electromagnetic Brake Motor | 4RK25GN-CWME | A-182 |
| | 4IK25GN-SWM | |
| Torque Motor | 4TK10GN-AUL | A-108 |

■ Models

| Rack Stroke inch (mm) | Basic Speed | | |
|-----------------------|-------------------|------------------|------------------|
| | 0.47in/s (12mm/s) | 1.2in/s (30mm/s) | 2.4in/s (60mm/s) |
| 3.9 (100) | 4LB10N-1 | 4LB20N-1 | 4LB45N-1 |
| | 4LF10N-1 | 4LF20N-1 | 4LF45N-1 |
| 7.9 (200) | 4LB10N-2 | 4LB20N-2 | 4LB45N-2 |
| | 4LF10N-2 | 4LF20N-2 | 4LF45N-2 |
| 11.8 (300) | 4LB10N-3 | 4LB20N-3 | 4LB45N-3 |
| | 4LF10N-3 | 4LF20N-3 | 4LF45N-3 |
| 15.7 (400) | 4LB10N-4 | 4LB20N-4 | 4LB45N-4 |
| | 4LF10N-4 | 4LF20N-4 | 4LF45N-4 |
| 19.7 (500) | 4LB10N-5 | 4LB20N-5 | 4LB45N-5 |
| | 4LF10N-5 | 4LF20N-5 | 4LF45N-5 |
| 23.6 (600) | 4LB10N-6 | 4LB20N-6 | 4LB45N-6 |
| | 4LF10N-6 | 4LF20N-6 | 4LF45N-6 |
| 27.6 (700) | 4LB10N-7 | 4LB20N-7 | 4LB45N-7 |
| | 4LF10N-7 | 4LF20N-7 | 4LF45N-7 |

Performance Examples with Several Motor Combinations

● Overrun Unit = inch (mm)

| Linear Head | 4LB10N-□ | 4LB20N-□ | 4LB45N-□ |
|--------------|------------|------------|------------|
| Motor | 4LF10N-□ | 4LF20N-□ | 4LF45N-□ |
| 4RK25GN-AWU | 0.11 (2.7) | 0.21 (5.4) | 0.43 (11) |
| 4RK25GN-AWMU | 0.05 (1.3) | 0.11 (2.7) | 0.22 (5.6) |

Overrun at motor shaft is estimated to be 6 revolutions for reversible motors and 3 revolutions for electromagnetic brake motor.

- The maximum thrust load that can be driven when operating the mechanism vertically is the maximum thrust force less the rack weight.
- When operating the mechanism horizontally using a guide or similar device to bear the load, ensure that the load weight is less than the maximum thrust force.

Direction of Rack Movement

The direction of rack movement is determined by the direction of motor rotation.

| Model | Motor Rotation | |
|----------|----------------|-------|
| | CW | CCW |
| 4LB10N-□ | Left | Right |
| 4LB20N-□ | Left | Right |
| 4LF10N-□ | Up | Down |
| 4LF20N-□ | Up | Down |
| 4LB45N-□ | Right | Left |
| 4LF45N-□ | Down | Up |

- Direction of rack movement is as viewed from the front side of the linear head.
- A dog mounted on the rack (optional) and limit switch are required to stop or reverse a rack. Dogs are available as optional accessories. Use dogs for stop and reverse operation.

Accessories (sold separately)

● Dog

A dog should be mounted on the rack to stop or reverse a rack. For details, see page A-273



● Dimensions Unit = inch. (mm)

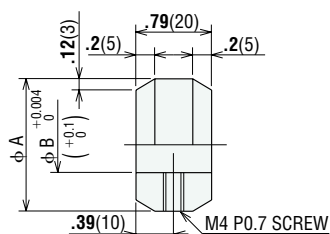

| Model | A inch (mm) | B inch (mm) |
|-------------------------|------------------------|-------------|
| For 4L type Linear Head | LXD4C 1.18 (30) | 0.78 (19.8) |

● Reversible Motor (4RK25GN-AWU)

| Model | 4LB10N-□ | 4LB20N-□ | 4LB45N-□ |
|----------------------------|------------|------------|-----------|
| Item | 4LF10N-□ | 4LF20N-□ | 4LF45N-□ |
| Max. Thrust Force lb. (kg) | 154 (70) | 128 (58) | 68.2 (31) |
| Holding Force lb. (N) | 46.2 (210) | 22.0 (100) | 11.0 (50) |

● Electromagnetic Brake Motor (4RK25GN-AWMU)

| Model | 4LB10N-□ | 4LB20N-□ | 4LB45N-□ |
|----------------------------|-----------|-----------|------------|
| Item | 4LF10N-□ | 4LF20N-□ | 4LF45N-□ |
| Max. Thrust Force lb. (kg) | 154 (70) | 128 (58) | 68.2 (31) |
| Holding Force lb. (N) | 154 (700) | 154 (700) | 72.6 (330) |

- Holding force is provided by the built-in friction brake of the reversible motor. The values given in the table vary depending on the temperature and the time of operation, and thus should only be used as reference.
- The maximum thrust load that can be driven when operating the mechanism vertically is the maximum thrust force less the rack weight.
- When operating the mechanism horizontally using a guide or similar device to bear the load, ensure that the load weight is less than the maximum thrust force.

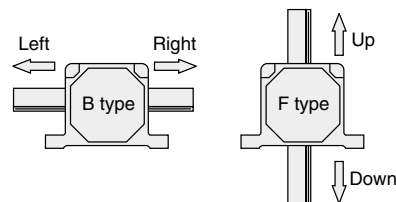

● Rack Cover

Rack covers for rack protection and dustproofing are available. For details, see Page A-256



■ **Dimensions** Scale 1/4, Unit = inch (mm)

4LB type (horizontal)

4LB□N-□/4RK25GN-AWU
4RK25GN-CWE
4RK25GN-AUL

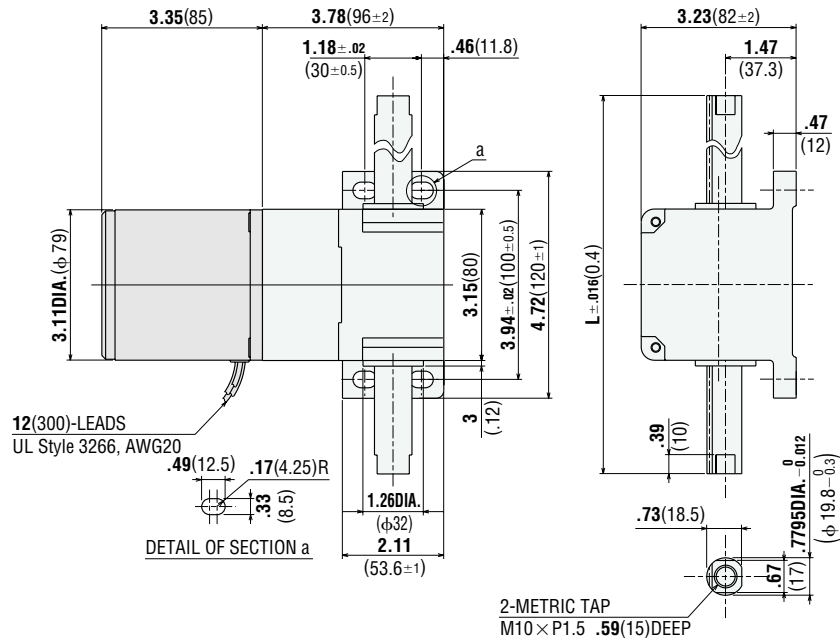

4LB□N-□/4RK25GN-AWTU
4RK25GN-CWTE

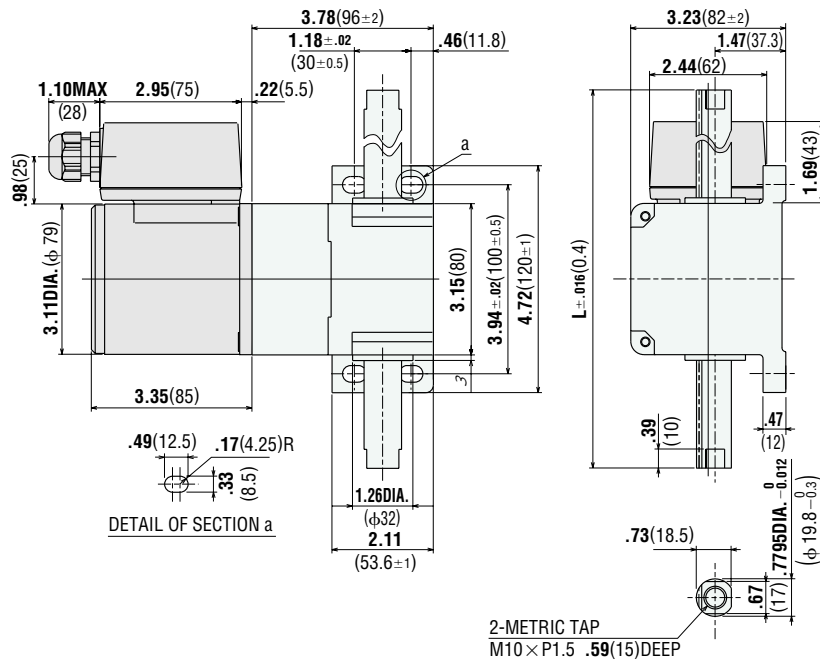

4LB□N-□/4RK25GN-AWMU
4RK25GN-CWME
4IK25GN-SWM
4RK25GN-AMUL

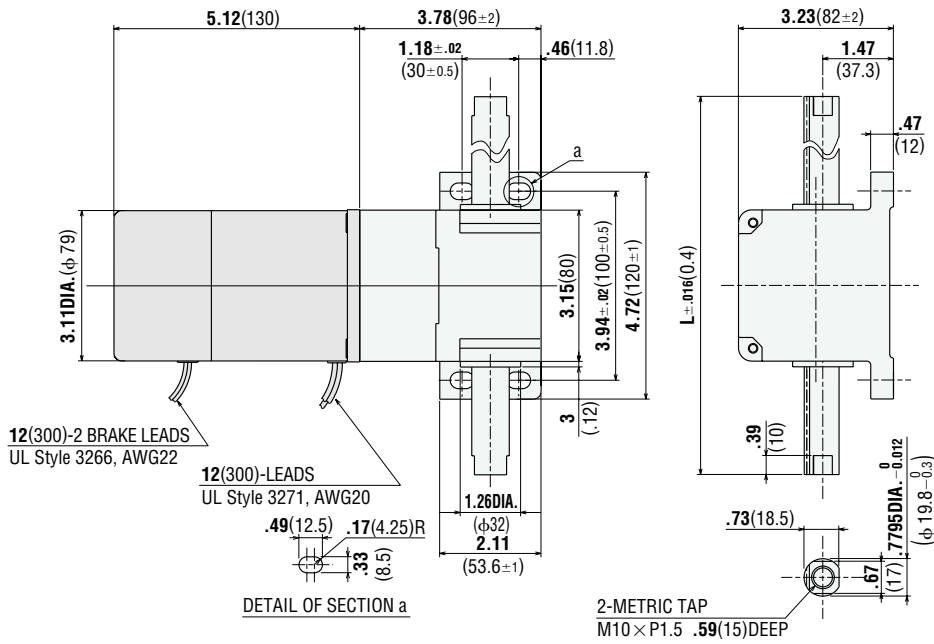

4LF type (vertical)

4LF□N-□/4RK25GN-AWU
4RK25GN-CWE
4RK25GN-AUL

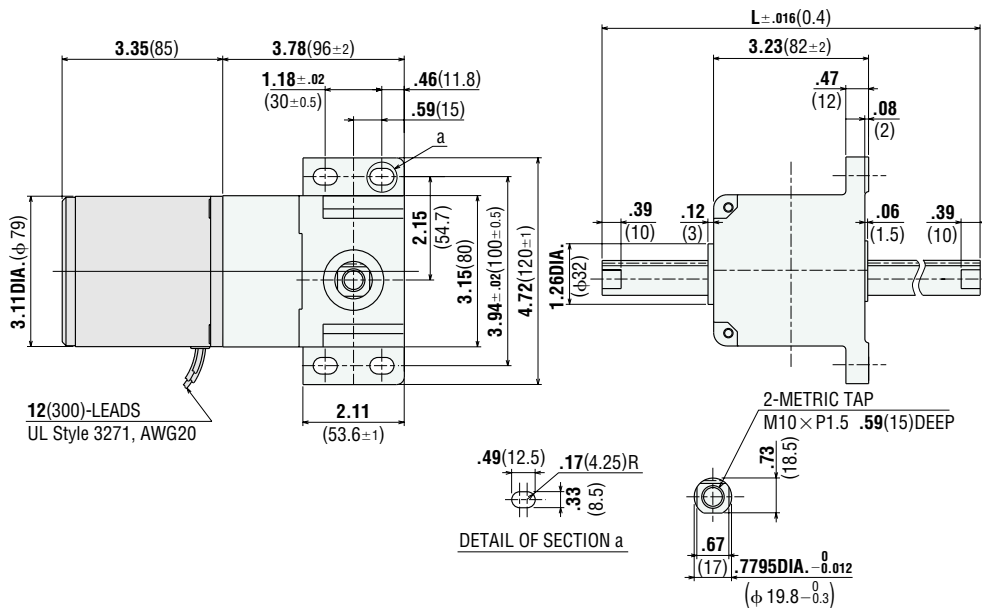

**4LF□N-□/4RK25GN-AWTU
4RK25GN-CWTE**

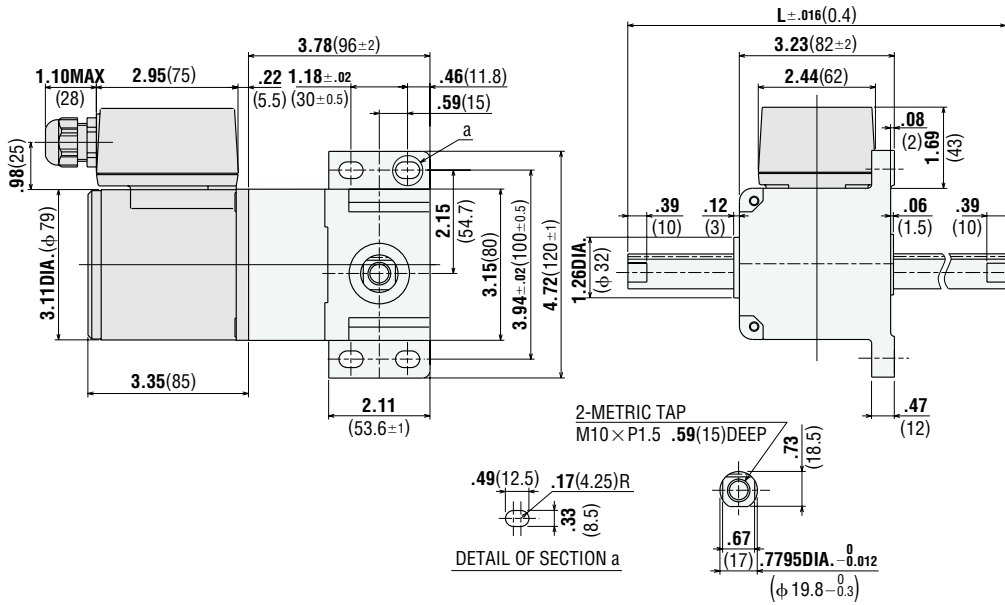

**4LF□N-□/4RK25GN-AWMU
4RK25GN-CWME
4IK25GN-SWM
4RK25GN-AMUL**

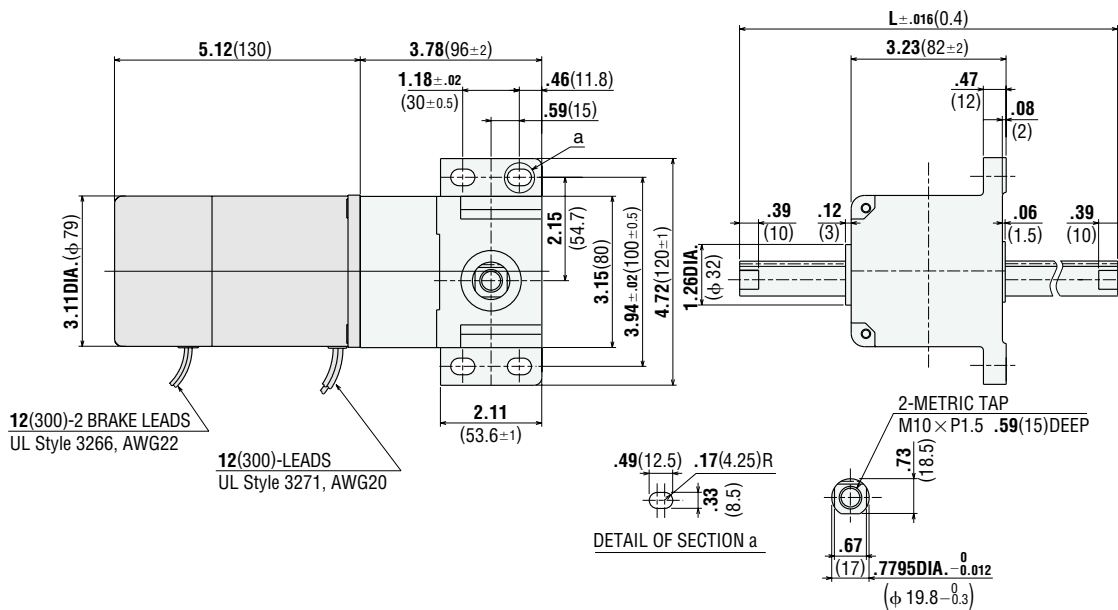

● **Weight, Stroke Length and Rack Length**

| Model | Stroke | Total Length L | Weight (Mass) | |
|-------------------------|------------|----------------|---------------|------------|
| | inch (mm) | | inch (mm) | lb. (kg) |
| 4LB□N-1, 4LF□N-1 | 3.9 (100) | 7.89 (200.4) | 3.52 (1.6) | 0.88 (0.4) |
| 4LB□N-2, 4LF□N-2 | 7.9 (200) | 11.91 (302.5) | 3.96 (1.8) | 1.54 (0.7) |
| 4LB□N-3, 4LF□N-3 | 11.8 (300) | 15.78 (400.7) | 4.40 (2.0) | 1.98 (0.9) |
| 4LB□N-4, 4LF□N-4 | 15.7 (400) | 19.80 (502.8) | 4.84 (2.2) | 2.42 (1.1) |
| 4LB□N-5, 4LF□N-5 | 19.7 (500) | 23.66 (601.0) | 5.28 (2.4) | 2.86 (1.3) |
| 4LB□N-6, 4LF□N-6 | 23.6 (600) | 27.68 (703.1) | 5.72 (2.6) | 3.52 (1.6) |
| 4LB□N-7, 4LF□N-7 | 27.6 (700) | 31.55 (801.3) | 6.16 (2.8) | 3.96 (1.8) |

5L-N type Linear Head

Max. Thrust Force

198lb.(90kg)

■ Max. Thrust Force

198lb. (90kg) Thrust force varies with basic speed and the motor combined.



■ Specifications

| Basic Speed | Model | Rack Stroke inch (mm) |
|-------------------|------------------|-----------------------|
| 0.47 in/s(12mm/s) | 5LB10N -□ | 3.9 (100) |
| | 5LB10N -□ | 7.9 (200) |
| 1.2 in/s(30mm/s) | 5LB20N -□ | 11.8 (300) |
| | 5LB20N -□ | 15.7 (400) |
| | 5LB20N -□ | 19.7 (500) |
| 2.4 in/s(60mm/s) | 5LB45N -□ | 23.6 (600) |
| | 5LB45N -□ | 27.6 (700) |

●Basic speed figures are based on synchronous speed(60Hz : 1800r/min). The actual speed varies with the load or frequency of the power source.

●The box (□) represents the code for stroke length.

■ Max. Permissible Overhung Load

| Rack Stroke inch (mm) | Max. Permissible Overhung Load lb. (kg) |
|-----------------------|---|
| 3.9 (100) | 28.6 (13) |
| 7.9 (200) | 22.0 (10) |
| 11.8 (300) | 17.6 (8) |
| 15.7 (400) | 13.2 (6) |
| 19.7 (500) | 11.0 (5) |
| 23.6 (600) | 11.0 (5) |
| 27.6 (700) | 8.8 (4) |

■ Motor Combination

| Motor type | Motor Model | Page |
|-----------------------------|-----------------------|-------|
| Reversible Motor | 5RK40GN-AW(T)U | A-93 |
| | 5RK40GN-CW(T)E | |
| Electromagnetic Brake Motor | 5RK40GN-AWMU | A-182 |
| | 5RK40GN-CWME | |
| | 5IK40GN-SWM | |
| Torque Motors | 5TK20GN-AUL | A-108 |

■ Models

| Rack Stroke inch (mm) | Basic Speed | | |
|-----------------------|-------------------|------------------|------------------|
| | 0.47in/s (12mm/s) | 1.2in/s (30mm/s) | 2.4in/s (60mm/s) |
| 3.9 (100) | 5LB10N-1 | 5LB20N-1 | 5LB45N-1 |
| | 5LF10N-1 | 5LF20N-1 | 5LF45N-1 |
| 7.9 (200) | 5LB10N-2 | 5LB20N-2 | 5LB45N-2 |
| | 5LF10N-2 | 5LF20N-2 | 5LF45N-2 |
| 11.8 (300) | 5LB10N-3 | 5LB20N-3 | 5LB45N-3 |
| | 5LF10N-3 | 5LF20N-3 | 5LF45N-3 |
| 15.7 (400) | 5LB10N-4 | 5LB20N-4 | 5LB45N-4 |
| | 5LF10N-4 | 5LF20N-4 | 5LF45N-4 |
| 19.7 (500) | 5LB10N-5 | 5LB20N-5 | 5LB45N-5 |
| | 5LF10N-5 | 5LF20N-5 | 5LF45N-5 |
| 23.6 (600) | 5LB10N-6 | 5LB20N-6 | 5LB45N-6 |
| | 5LF10N-6 | 5LF20N-6 | 5LF45N-6 |
| 27.6 (700) | 5LB10N-7 | 5LB20N-7 | 5LB45N-7 |
| | 5LF10N-7 | 5LF20N-7 | 5LF45N-7 |

●Longer mounting screws are required if a decimal gearhead is used.

■ Performance Examples with Several Motor Combinations

● Overrun Unit = inch (mm)

| Motor | Linear Head | | |
|---------------|-------------|------------|------------|
| | 5LB10N-□ | 5LB20N-□ | 5LB45N-□ |
| 5SRK40GN-AWU | 0.10 (2.6) | 0.20 (5.1) | 0.51 (13) |
| 5SRK40GN-AWMU | 0.05 (1.3) | 0.10 (2.6) | 0.25 (6.3) |

Overrun at motor shaft is estimated to be 6 revolutions for reversible motors and 3 revolutions for electromagnetic brake motors.

- The maximum thrust load that can be driven when operating the mechanism vertically is the maximum thrust force less the rack weight.
- When operating the mechanism horizontally using a guide or similar device to bear the load, ensure that the load weight is less than the maximum thrust force.

■ Direction of Rack Movement

The direction of rack movement is determined by the direction of motor rotation.

| Model | Motor Rotation | |
|----------|----------------|-------|
| | CW | CCW |
| 5LB10N-□ | Right | Left |
| 5LB20N-□ | | |
| 5LF10N-□ | Up | Down |
| 5LF20N-□ | | |
| 5LB45N-□ | Left | Right |
| 5LF45N-□ | Down | Up |

- Direction of rack movement is as viewed from the front side of the linear head.
- A dog mounted on the rack (optional) and limit switch are required to stop or reverse a rack. Dogs are available as optional accessories. Use dogs for stop and reverse operation.

■ Accessories (sold separately)

● Dog

A dog should be mounted on the rack to stop or reverse a rack. For details, see page A-273.



● Dimensions Unit = inch (mm)

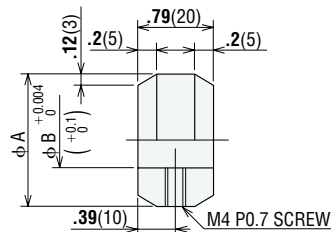

| Model | A inch (mm) | B inch (mm) |
|-------------------------|-------------|-------------|
| For 5L type Linear Head | | |
| LXD5C | 1.38 (35) | 0.98 (24.8) |

● Reversible Motor (5SRK40GN-AWU)

| Item | Model | | |
|-------------------------------|------------|-----------|------------|
| | 5LB10N-□ | 5LB20N-□ | 5LB45N-□ |
| Max. Thrust Force lb. (kg) | 198 (90) | 198 (90) | 112.2 (51) |
| | 5LF10N-□ | 5LF20N-□ | 5LF45N-□ |
| Holding Force lb. (N) | 1320 (600) | 660 (300) | 264 (120) |

● Electromagnetic Brake Motor (5SRK40GN-AWMU)

| Item | Model | | |
|-------------------------------|------------|------------|------------|
| | 5LB10N-□ | 5LB20N-□ | 5LB45N-□ |
| Max. Thrust Force lb. (kg) | 198 (90) | 198 (90) | 112.2 (51) |
| | 5LF10N-□ | 5LF20N-□ | 5LF45N-□ |
| Holding Force lb. (N) | 1980 (900) | 1980 (900) | 1122 (510) |

- Holding force is provided by the built-in friction brake of the reversible motor. The values given in the table vary depending on the temperature and the time of operation, and thus should only be used as reference.
- The maximum thrust load that can be driven when operating the mechanism vertically is the maximum thrust force less the rack weight.
- When operating the mechanism horizontally using a guide or similar device to bear the load, ensure that the load weight is less than the maximum thrust force.

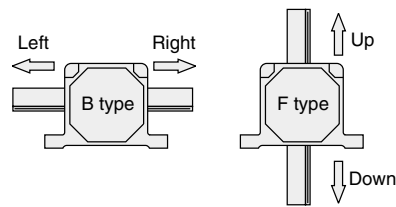

● Rack Cover

Rack covers for rack protection and dustproofing are available. For details, see Page A-256.



■ Dimensions Scale 1/4, Unit = inch (mm)

5LB type (horizontal)

5LB□N-□/5RK40GN-AWU
5RK40GN-CWE
5RK40GN-AUL

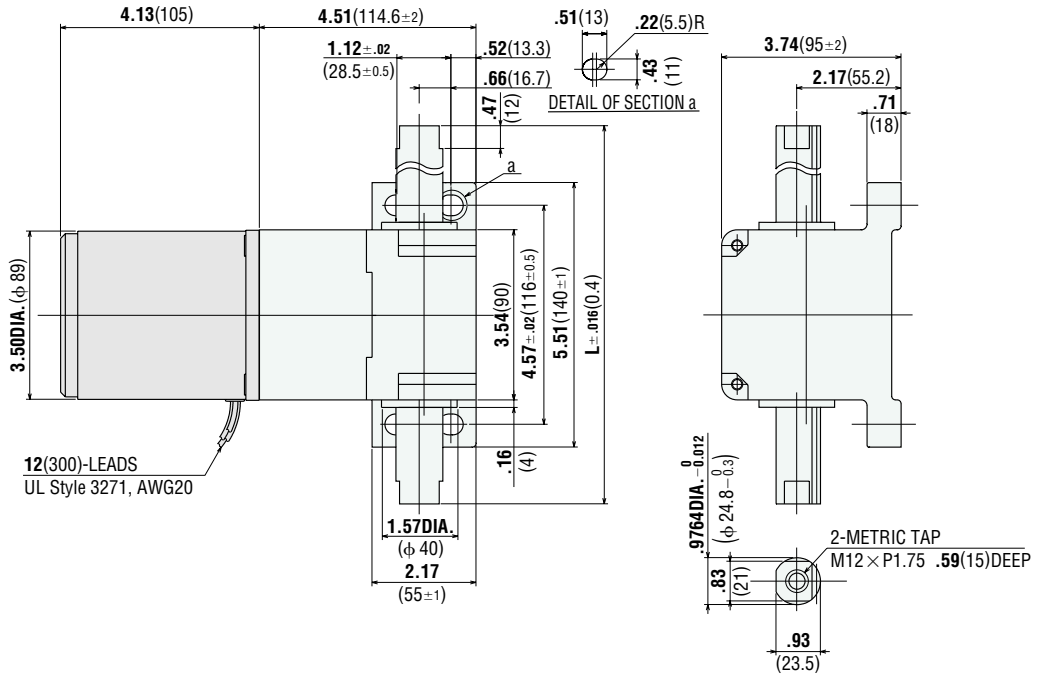

5LB□N-□/5RK40GN-AWTU
5RK40GN-CWTE

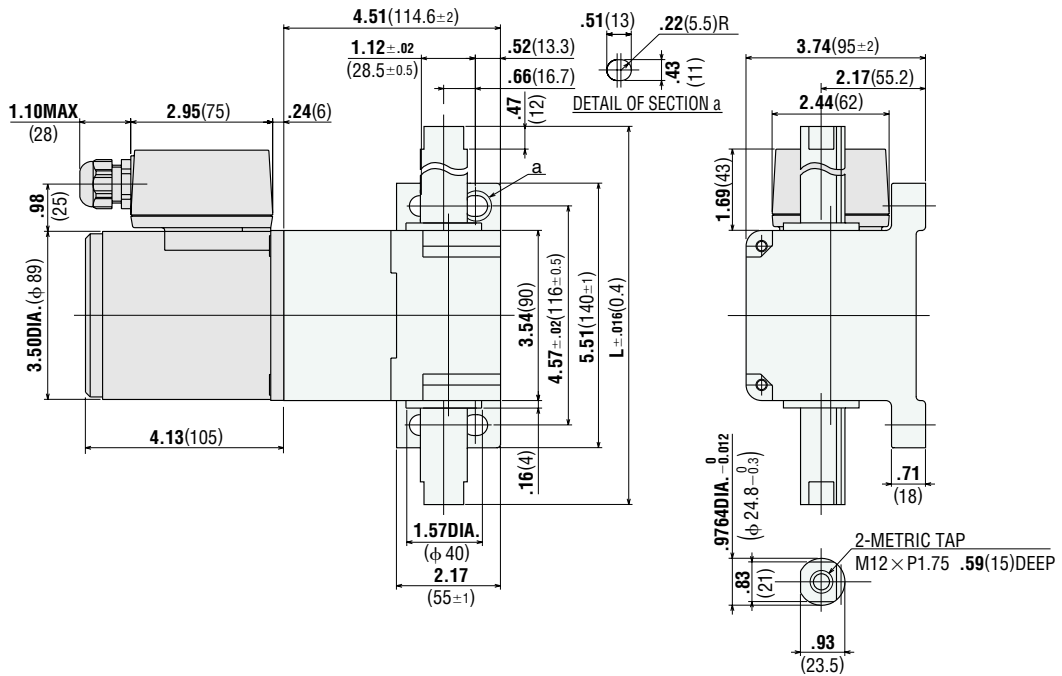

5LB□N-□/5RK40GN-AWMU
5RK40GN-CWME
5IK40GN-SWM
5RK40GN-AMUL

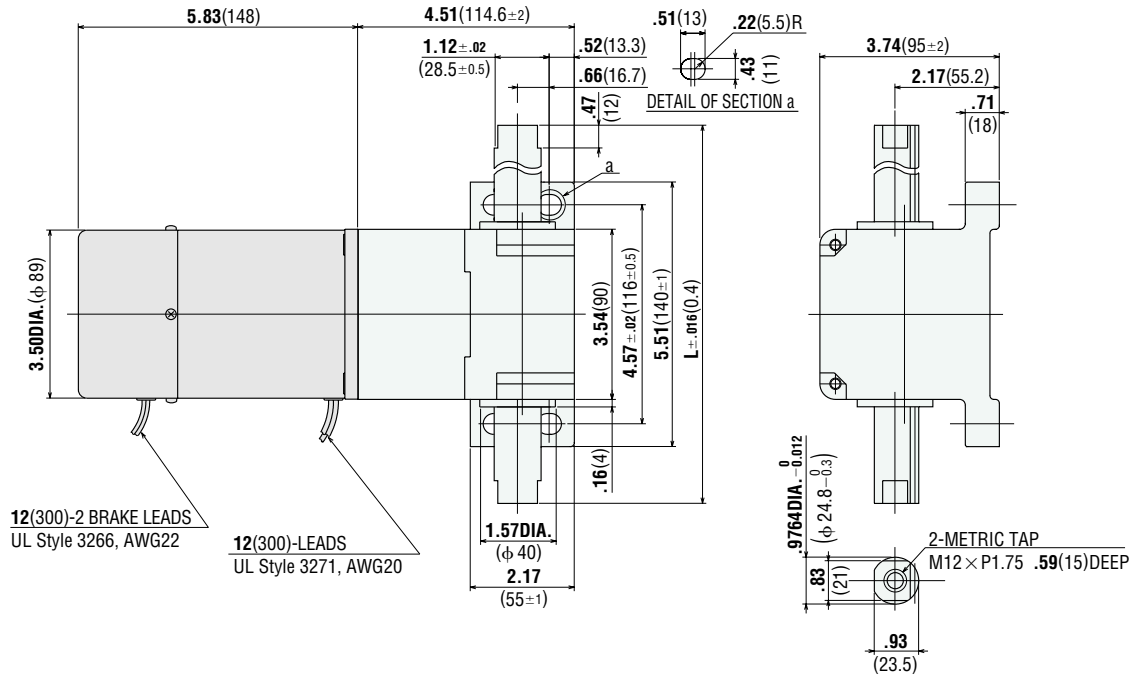

5LF type (vertical)

5LF□N-□/5RK40GN-AWU
5RK40GN-CWE
5RK40GN-AUL

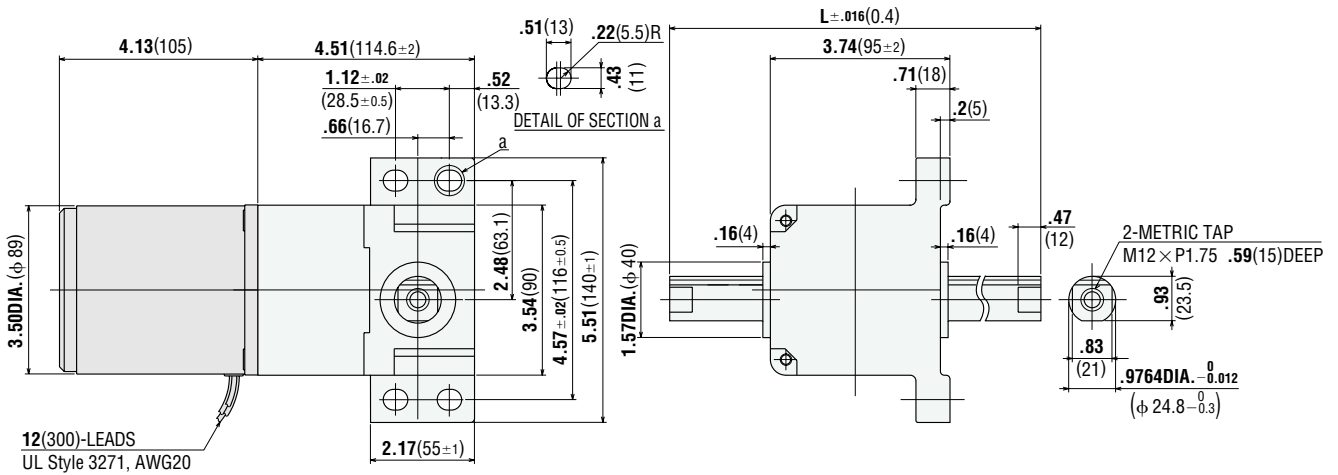

5LF□N-□/5RK40GN-AWTU
5RK40GN-CWTE

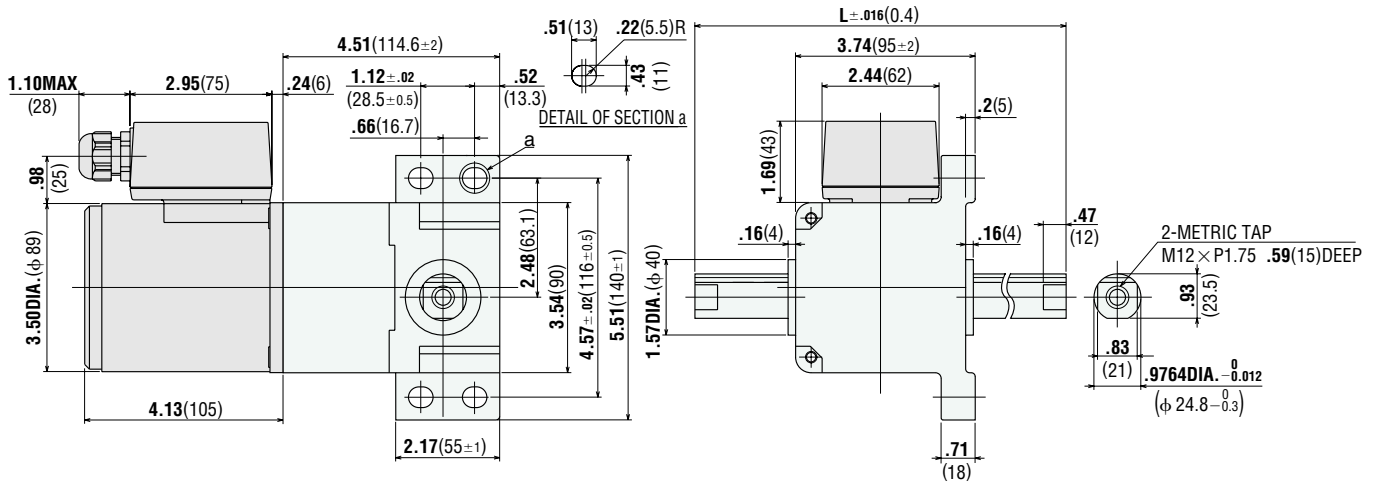

5LF□N-□/5RK40GN-AWMU
5RK40GN-CWME
5IK40GN-SWM
5RK40GN-AMUL

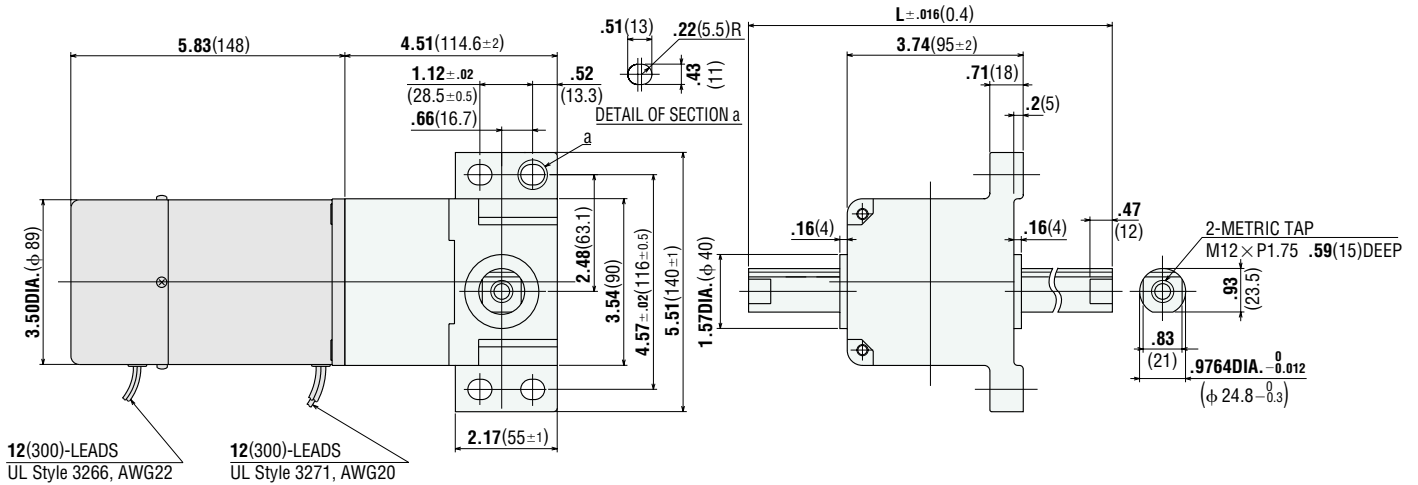

● **Weight, Stroke Length and Rack Length**

| Model | Rack Stroke inch (mm) | Rack Length L inch (mm) | Weight (Mass) lb. (kg) | Rack Weight (Mass) lb. (kg) |
|-------------------------|--------------------------|----------------------------|---------------------------|--------------------------------|
| 5LB□N-1, 5LF□N-1 | 3.9 (100) | 10.14 (257.6) | 6.38 (2.9) | 1.98 (0.9) |
| 5LB□N-2, 5LF□N-2 | 7.9 (200) | 14.10 (358.1) | 7.04 (3.2) | 2.64 (1.2) |
| 5LB□N-3, 5LF□N-3 | 11.8 (300) | 18.06 (458.6) | 7.92 (3.6) | 3.52 (1.6) |
| 5LB□N-4, 5LF□N-4 | 15.7 (400) | 22.02 (559.2) | 8.58 (3.9) | 4.18 (1.9) |
| 5LB□N-5, 5LF□N-5 | 19.7 (500) | 25.97 (659.7) | 9.46 (4.3) | 5.06 (2.3) |
| 5LB□N-6, 5LF□N-6 | 23.6 (600) | 29.93 (760.3) | 10.34 (4.7) | 5.94 (2.7) |
| 5LB□N-7, 5LF□N-7 | 27.6 (700) | 33.89 (860.8) | 11.0 (5.0) | 6.6 (3.0) |

5L-U type Linear Head

Max. Thrust Force

308lb.(140kg)

■ Max. Thrust Force

308 lb. (140 kg). Thrust force varies with basic speed and the motor combined.



■ Specifications

| Basic Speed | Model | Rack Stroke inch (mm) |
|---------------------|----------|-----------------------|
| 0.47 in/s (12 mm/s) | 5LB10U-□ | 3.9 (100) |
| | 5LF10U-□ | 7.9 (200) |
| | | 11.8 (300) |
| 0.94 in/s (24mm/s) | 5LB20U-□ | 15.7 (400) |
| | 5LF20U-□ | 19.7 (500) |
| 2.4 in/s (60 mm/s) | 5LB45U-□ | 23.6 (600) |
| | 5LF45U-□ | 27.6 (700) |

●Basic speed figures are based on synchronous speed (60Hz : 1800r/min). The actual speed varies with the load or frequency of the power source.

●The box (□) represents the code for stroke length.

■ Max. Permissible Overhung Load

| Stroke inch (mm) | Max. Permissible Overhung Load | |
|---------------------|--------------------------------|------|
| | lb. | (kg) |
| 3.9 (100) | 28.6 | (13) |
| 7.9 (200) | 22.0 | (10) |
| 11.8 (300) | 17.6 | (8) |
| 15.7 (400) | 13.2 | (6) |
| 19.7 (500) | 11.0 | (5) |
| 23.6 (600) | 11.0 | (5) |
| 27.6 (700) | 8.8 | (4) |

■ Motor Combination

| Motor type | Motor Model | Page |
|-----------------------------|----------------|-------|
| Reversible Motor | 5RK60GU-AW(T)U | A-96 |
| | 5RK60GU-CW(T)E | |
| | 5RK90GU-AW(T)U | A-99 |
| | 5RK90GU-CW(T)E | |
| Electromagnetic Brake Motor | 5RK60GU-AWMU | A-182 |
| | 5RK60GU-CWME | |
| | 5IK60GU-SWM | |
| | 5RK90GU-AWMU | A-182 |
| | 5RK90GU-CWME | |
| | 5IK90GU-SWM | |

■ Models

| Rack Stroke inch (mm) | Basic Speed | | |
|--------------------------|-------------------|-------------------|------------------|
| | 0.47in/s (12mm/s) | 0.94in/s (24mm/s) | 2.4in/s (60mm/s) |
| 3.9 (100) | 5LB10U-1 | 5LB20U-1 | 5LB45U-1 |
| | 5LF10U-1 | 5LF20U-1 | 5LF45U-1 |
| 7.9 (200) | 5LB10U-2 | 5LB20U-2 | 5LB45U-2 |
| | 5LF10U-2 | 5LF20U-2 | 5LF45U-2 |
| 11.8 (300) | 5LB10U-3 | 5LB20U-3 | 5LB45U-3 |
| | 5LF10U-3 | 5LF20U-3 | 5LF45U-3 |
| 15.7 (400) | 5LB10U-4 | 5LB20U-4 | 5LB45U-4 |
| | 5LF10U-4 | 5LF20U-4 | 5LF45U-4 |
| 19.7 (500) | 5LB10U-5 | 5LB20U-5 | 5LB45U-5 |
| | 5LF10U-5 | 5LF20U-5 | 5LF45U-5 |
| 23.6 (600) | 5LB10U-6 | 5LB20U-6 | 5LB45U-6 |
| | 5LF10U-6 | 5LF20U-6 | 5LF45U-6 |
| 27.6 (700) | 5LB10U-7 | 5LB20U-7 | 5LB45U-7 |
| | 5LF10U-7 | 5LF20U-7 | 5LF45U-7 |

●Longer mounting screws are required if a decimal gearhead is used.

■ Performance Example with Several Motor Combinations

● Reversible Motors

| Model | 5LB10U-□ 5LF10U-□ | | 5LB20U-□ 5LF20U-□ | | 5LB45U-□ 5LF45U-□ | |
|--------------------|-------------------------------|--------------------------|-------------------------------|--------------------------|-------------------------------|--------------------------|
| | Max. Thrust Force lb. (kg) | Holding Force lb. (N) | Max. Thrust Force lb. (kg) | Holding Force lb. (N) | Max. Thrust Force lb. (kg) | Holding Force lb. (N) |
| 5RK60GU-AWU | 308 (140) | 132 (600) | 308 (140) | 66 (300) | 147 (67) | 26.4 (120) |
| 5RK90GU-AWU | 308 (140) | 132 (600) | 308 (140) | 66 (300) | 229 (104) | 26.4 (120) |

●Holding force is provided by the built-in friction brake of the reversible motor. The values given in the table vary depending on the temperature and the time of operation, and thus should only be used as reference.

● Electromagnetic Brake Motors

| Model | 5LB10U-□ 5LF10U-□ | | 5LB20U-□ 5LF20U-□ | | 5LB45U-□ 5LF45U-□ | |
|---------------------|-------------------------------|--------------------------|-------------------------------|--------------------------|-------------------------------|--------------------------|
| | Max. Thrust Force lb. (kg) | Holding Force lb. (N) | Max. Thrust Force lb. (kg) | Holding Force lb. (N) | Max. Thrust Force lb. (kg) | Holding Force lb. (N) |
| 5RK60GU-AWMU | 308 (140) | 308 (1400) | 308 (140) | 308 (1400) | 147 (67) | 147 (670) |
| 5RK90GU-AWMU | 308 (140) | 308 (1400) | 308 (140) | 308 (1400) | 229 (104) | 229 (1040) |

- The maximum thrust load that can be driven when operating the mechanism vertically is the maximum thrust force less the rack weight.
- When operating the mechanism horizontally using a guide or similar device to bear the load, ensure that the load weight is less than the maximum thrust force.

● Overrun Unit = inch (mm)

| Motor | Linear Head | | |
|--|----------------------|----------------------|----------------------|
| | 5LB10U-□ 5LF10U-□ | 5LB20U-□ 5LF20U-□ | 5LB45U-□ 5LF45U-□ |
| 5RK60GU-AWU 5RK90GU-AWU | 0.10 (2.6) | 0.20 (5.1) | 0.51 (13) |
| 5RK60GU-AWMU 5RK90GU-AWMU | 0.05 (1.3) | 0.10 (2.6) | 0.25 (6.3) |

Overrun at motor shaft is estimated to be 6 revolutions for reversible motors and 3 revolutions for electromagnetic brake motors.

- The maximum thrust load that can be driven when operating the mechanism vertically is the maximum thrust force less the rack weight.
- When operating the mechanism horizontally using a guide or similar device to bear the load, ensure that the load weight is less than the maximum thrust force.

■ Direction of Rack Movement

The direction of rack movement is determined by the direction of motor rotation.

| Model | Motor Rotation | |
|------------------------------------|----------------|-------|
| | CW | CCW |
| 5LB10U-□ 5LB20U-□ | Left | Right |
| 5LF10U-□ 5LF20U-□ | Down | Up |
| 5LB45U-□ 5LF45U-□ | Right | Left |
| | Up | Down |

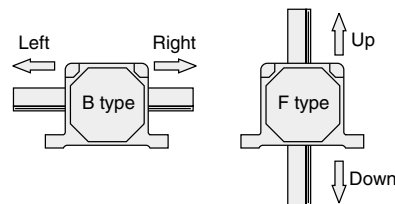

- Direction of rack movement is as viewed from the front side of the linear head.
- A dog mounted on the rack (optional) and limit switch are required to stop or reverse a rack. Dogs are available as optional accessories. Use dogs for stop and reverse operation.□

■ Accessories (sold separately)

● Dog

A dog should be mounted on the rack to stop or reverse a rack. For details, see page A-273



●Dimensions Unit = inch (mm)

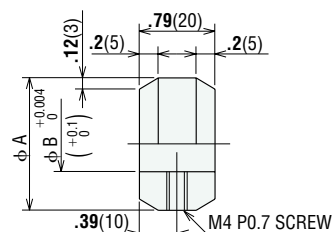

| Model | A inch (mm) | B inch (mm) |
|--|-------------|-------------|
| For 5L type Linear Head LXD5C | 1.38 (35) | 0.98 (24.8) |

● Rack Cover

Rack covers for rack protection and dustproofing are available. For details, see Page A-256



■ **Dimensions** Scale 1/4, Unit = inch (mm)

5LB type (horizontal)

5LB□U-□/5RK60GU-AWU
5RK60GU-CWE
5RK60GU-AFUL

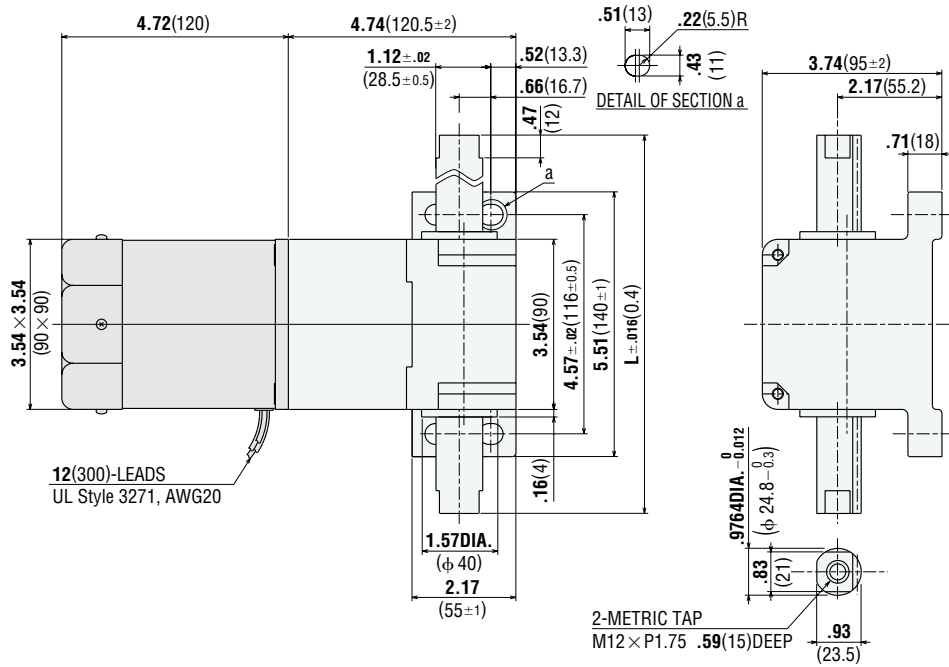

5LB□U-□/5RK60GU-AWTU
5RK60GU-CWTE

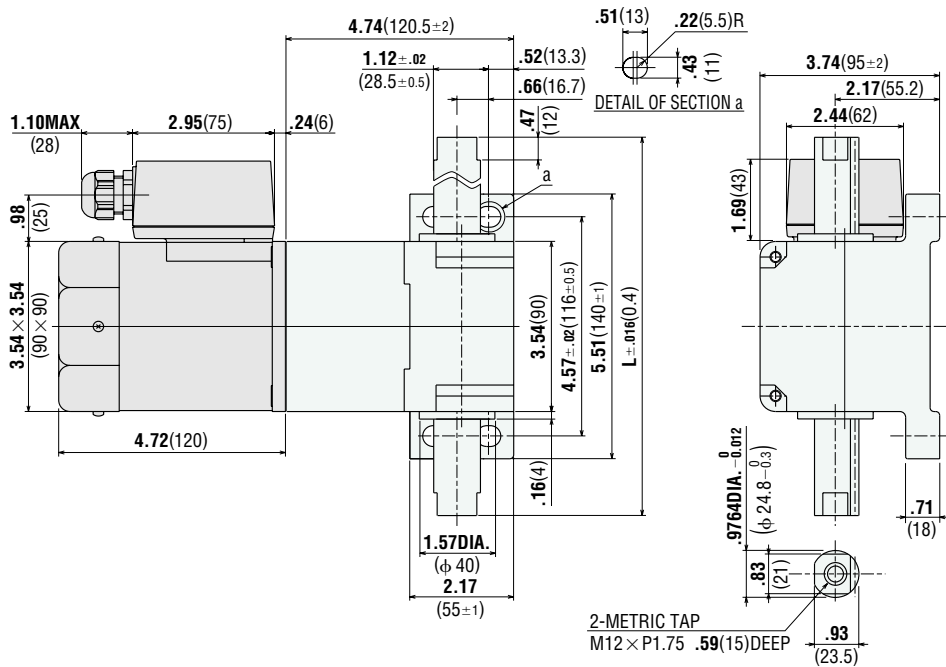

5LB□U-□/5RK60GU-AWMU
5RK60GU-CWME
5IK60GU-SWM
5RK60GU-AMUL

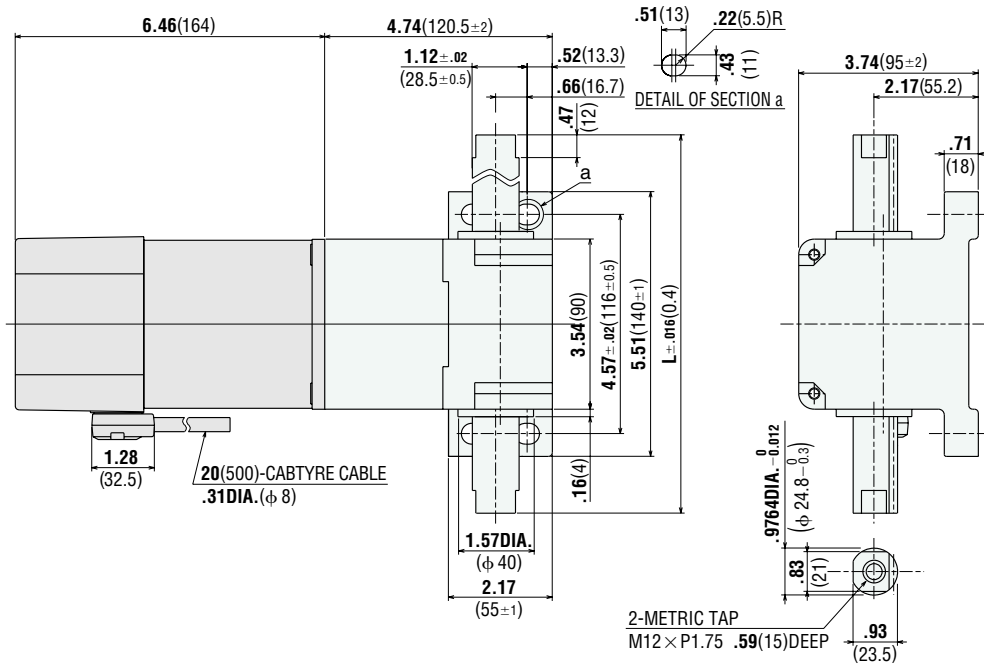

5LB□U-□/5RK90GU-AWU
5RK90GU-CWE
5RK90GU-AFUL

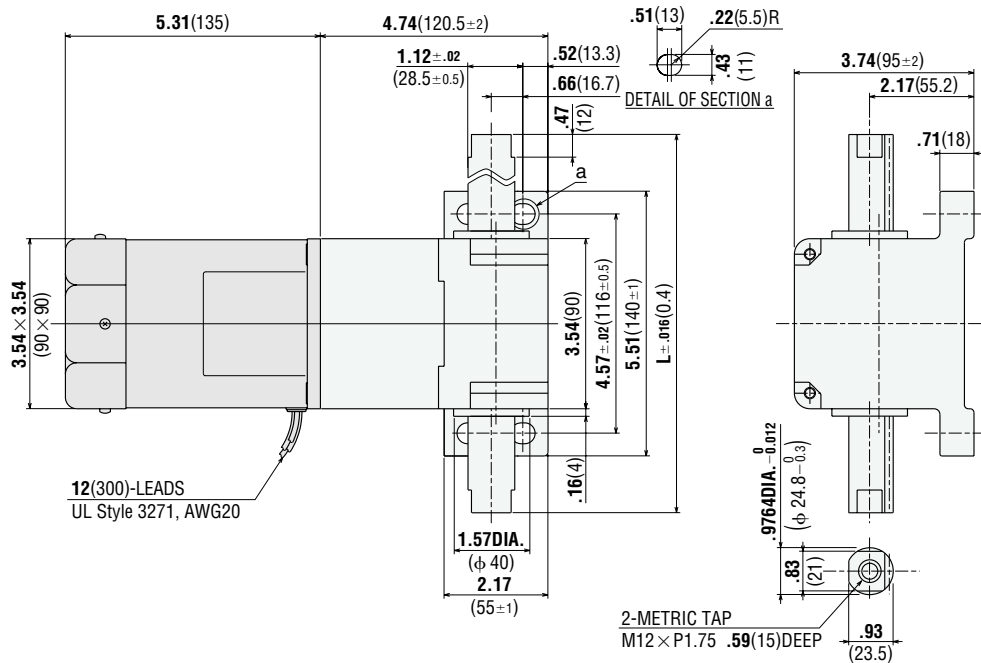

5LB□U-□/5RK90GU-AWTU
5RK90GU-CWTE

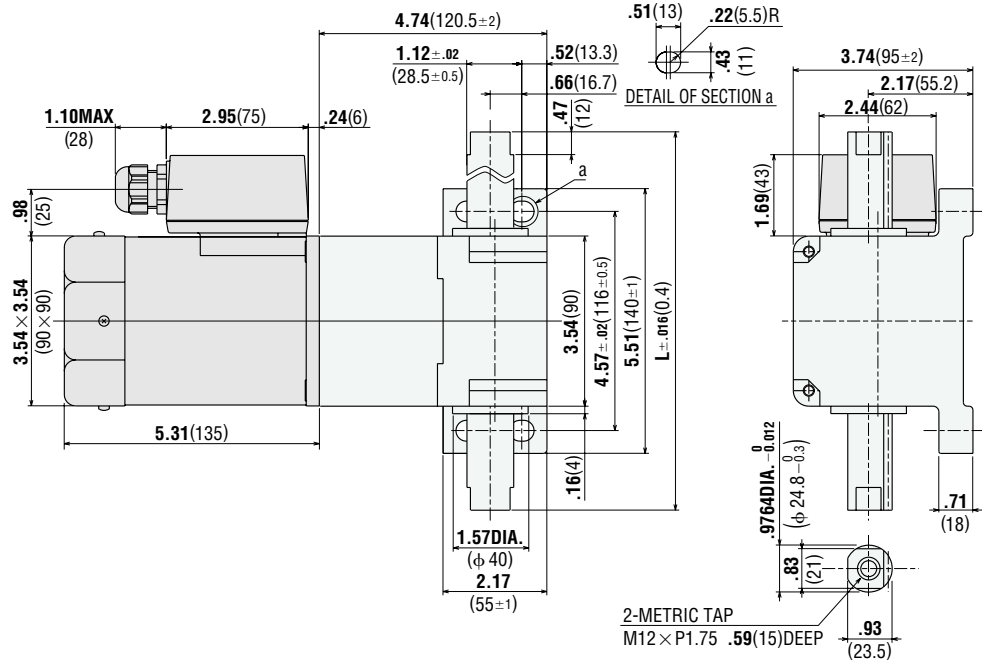

5LB□U-□/5RK90GU-AWMU
5RK90GU-CWME
5IK90GU-SWM
5RK90GU-AMUL

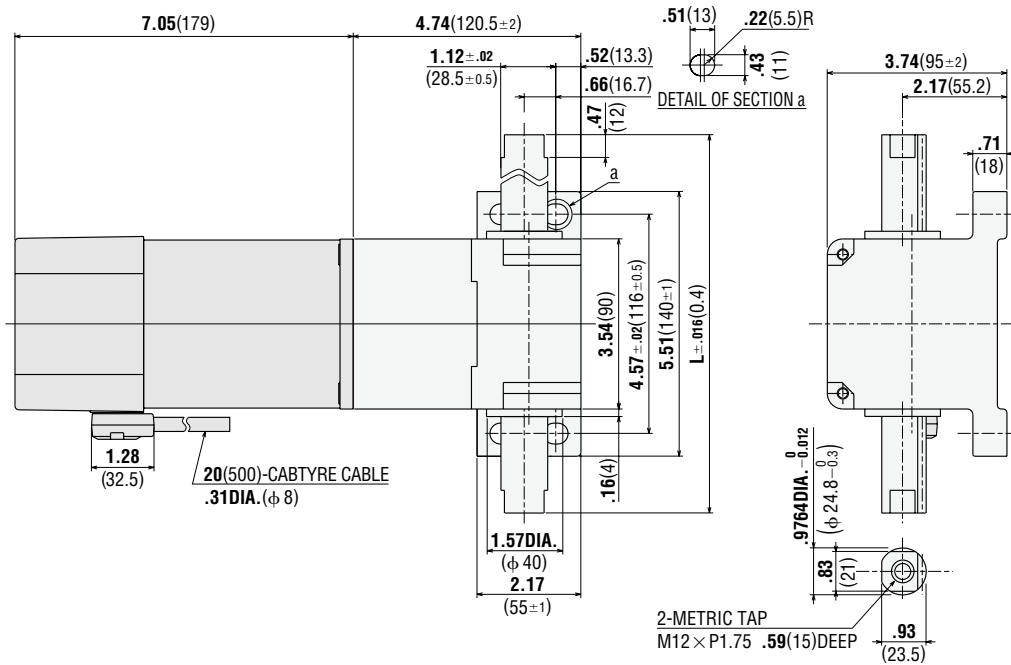

● **Weight, Stroke Length and Rack Length**

| Model | Stroke inch (mm) | Total Length L inch (mm) | Weight (Mass) lb. (kg) | Rack Weight (Mass) lb. (kg) |
|-------------------------|---------------------|-----------------------------|---------------------------|--------------------------------|
| 5LB□U-1, 5LF□U-1 | 3.9 (100) | 10.14 (257.6) | 7.04 (3.2) | 1.98 (0.9) |
| 5LB□U-2, 5LF□U-2 | 7.9 (200) | 14.10 (358.1) | 7.92 (3.6) | 2.64 (1.2) |
| 5LB□U-3, 5LF□U-3 | 11.8 (300) | 18.06 (458.6) | 8.58 (3.9) | 3.52 (1.6) |
| 5LB□U-4, 5LF□U-4 | 15.7 (400) | 22.02 (559.2) | 9.46 (4.3) | 4.18 (1.9) |
| 5LB□U-5, 5LF□U-5 | 19.7 (500) | 25.97 (659.7) | 10.12 (4.6) | 5.06 (2.3) |
| 5LB□U-6, 5LF□U-6 | 23.6 (600) | 29.93 (760.3) | 11.0 (5.0) | 5.94 (2.7) |
| 5LB□U-7, 5LF□U-7 | 27.6 (700) | 33.89 (860.8) | 11.88 (5.4) | 6.6 (3.0) |

5LF type (vertical)

5LF□U-□/5RK60GU-AWU
5RK60GU-CWE
5RK60GU-AFUL

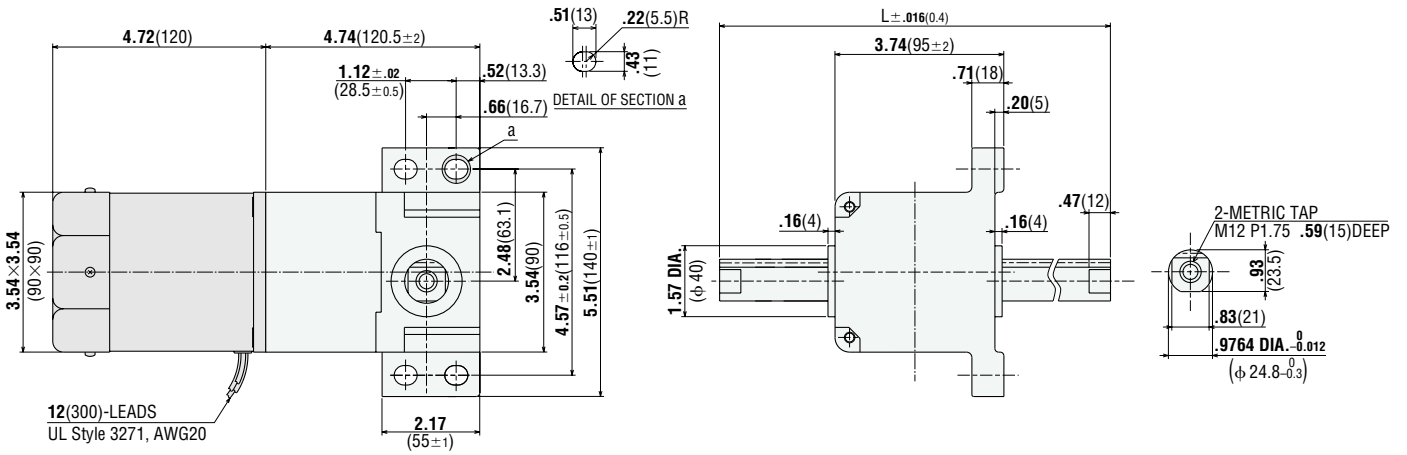

5LF□U-□/5RK60GU-AWTU
5RK60GU-CWTE

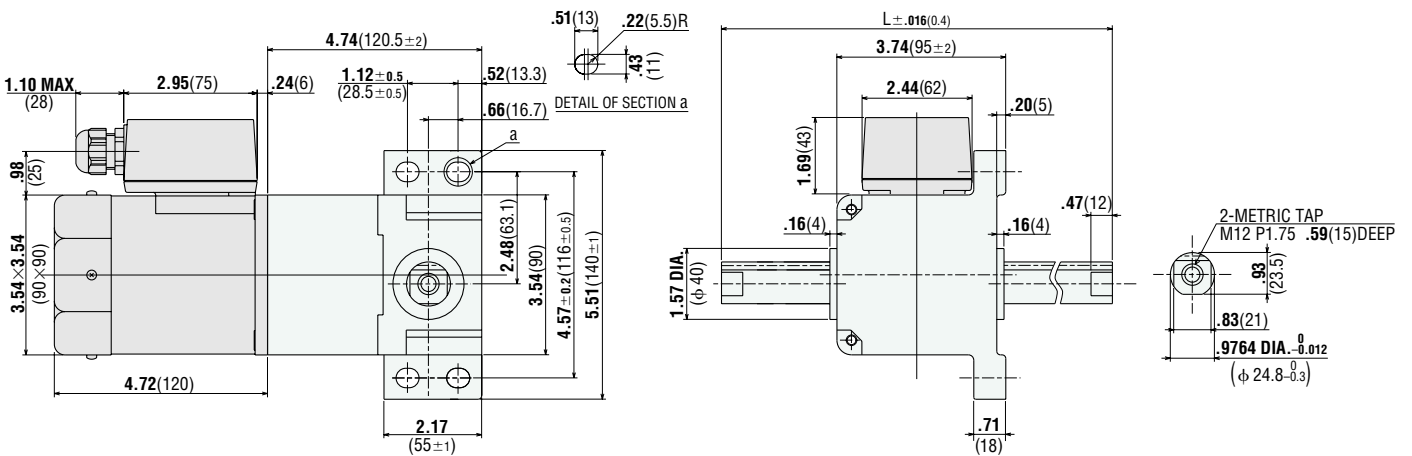

5LF□U-□/5RK60GU-AWMU
5RK60GU-CWME
5IK60GU-SWM
5RK60GU-AMUL

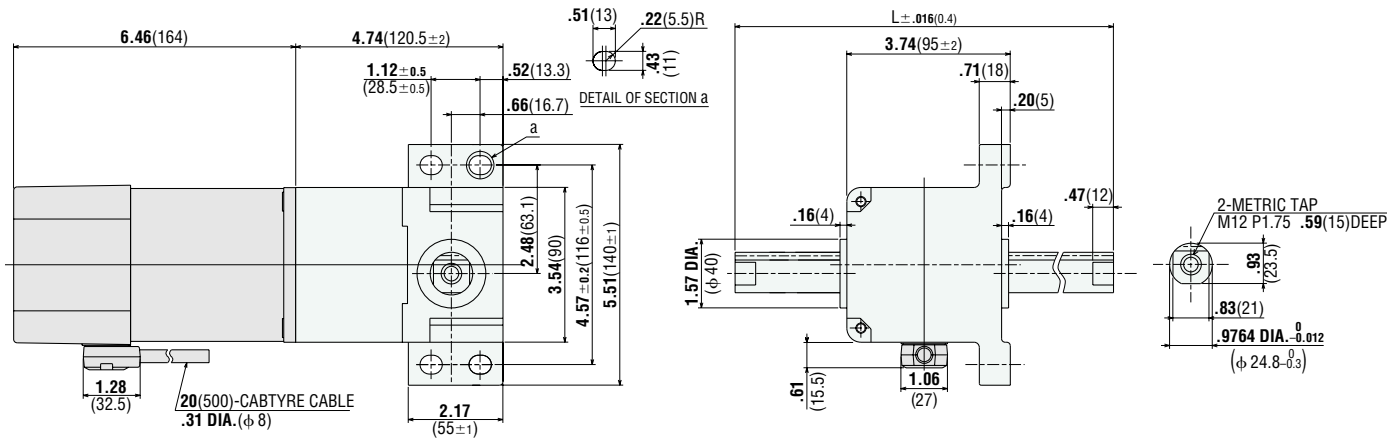

5LF□U-□/5RK90GU-AWU
5RK90GU-CWE
5RK90GU-AFUL

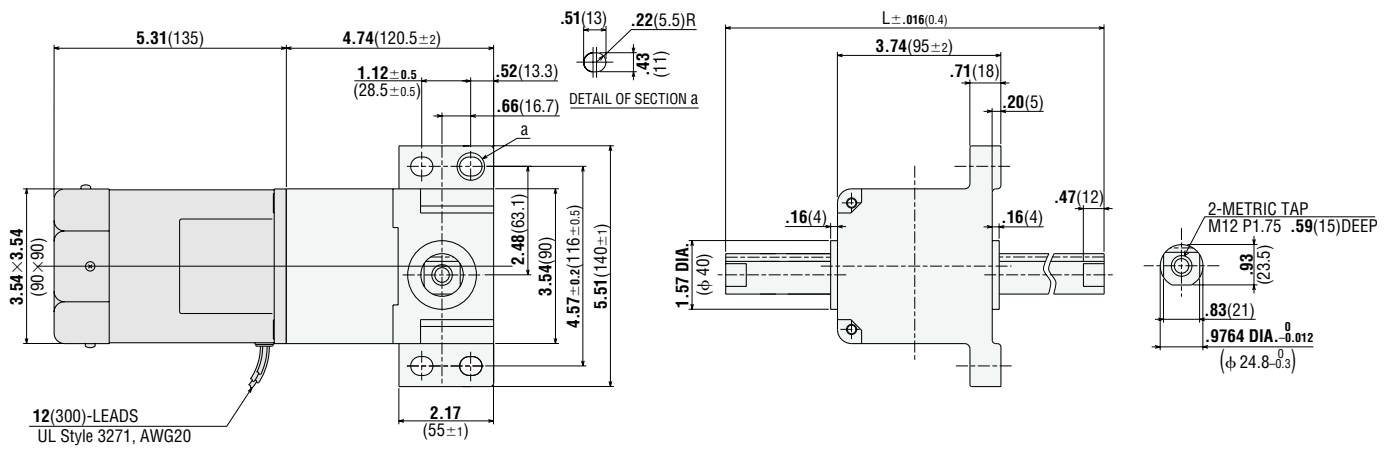

**5LF□U-□/5RK90GU-AWTU
5RK90GU-CWTE**

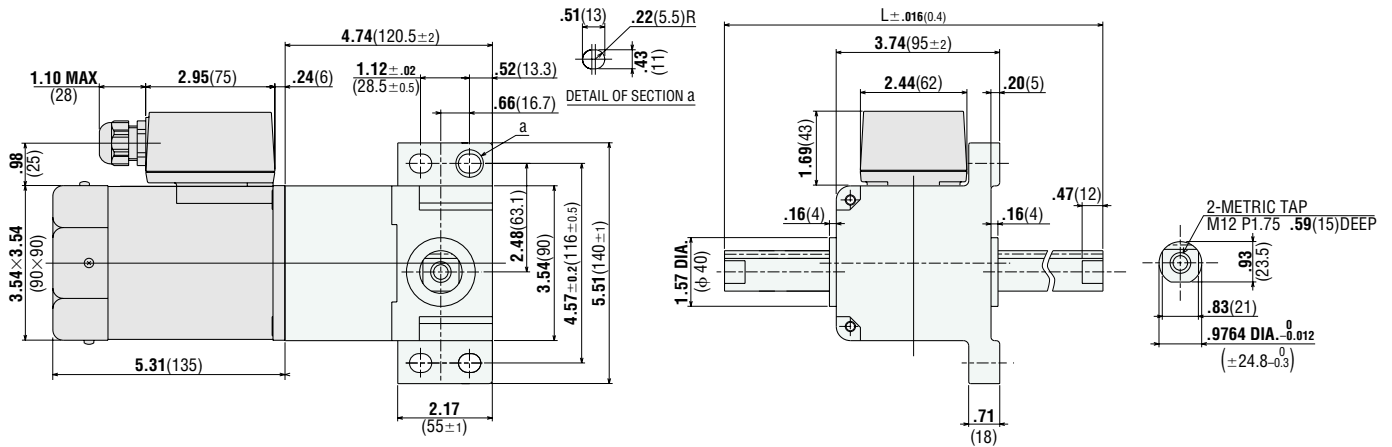

**5LF□U-□/5RK90GU-AWMU
5RK90GU-CWME
5IK90GU-SWM
5RK90GU-AMUL**

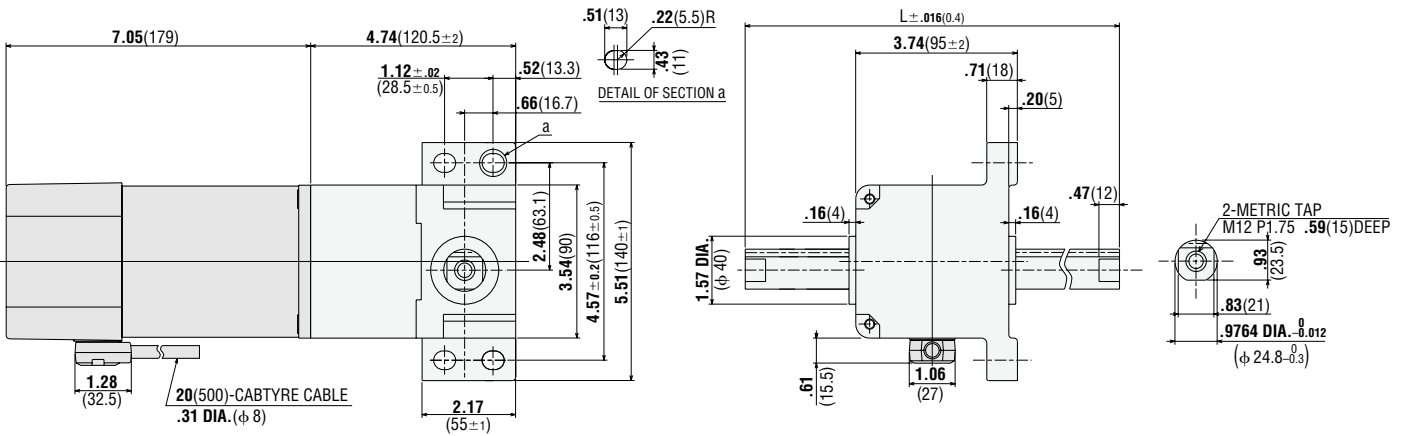

● **Weight, Stroke Length and Rack Length**

| Model | Stroke | Total Length L | Weight (Mass) | Rack Weight (Mass) |
|--------------------------|------------|----------------|---------------|--------------------|
| | inch (mm) | inch (mm) | lb. (kg) | lb. (kg) |
| 5LB□U-1, 5LF□U-1 | 3.9 (100) | 10.14 (257.6) | 7.04 (3.2) | 1.98 (0.9) |
| 5LB□U-2, 5LF□U-2 | 7.9 (200) | 14.10 (358.1) | 7.92 (3.6) | 2.64 (1.2) |
| 5LB□U-3, 5LFv□U-3 | 11.8 (300) | 18.06 (458.6) | 8.58 (3.9) | 3.52 (1.6) |
| 5LB□U-4, 5LF□U-4 | 15.7 (400) | 22.02 (559.2) | 9.46 (4.3) | 4.18 (1.9) |
| 5LB□U-5, 5LF□U-5 | 19.7 (500) | 25.97 (659.7) | 10.12 (4.6) | 5.06 (2.3) |
| 5LB□U-6, 5LF□U-6 | 23.6 (600) | 29.93 (760.3) | 11.0 (5.0) | 5.94 (2.7) |
| 5LB□U-7, 5LF□U-7 | 27.6 (700) | 33.89 (860.8) | 11.88 (5.4) | 6.6 (3.0) |

■ Rack cover for linear head

This is for dustproofing the linear head rack section. After passing the rack cover over the rack, you can use the accessory installation fittings to easily install the rack cover. When using rack covers installed on both sides, please purchase the stand-alone rack cover together with this rack cover.



F type
(Vertical Stroke type)



B type
(Horizontal Stroke type)

F type

● **Dimensions** Unit = inch (mm)

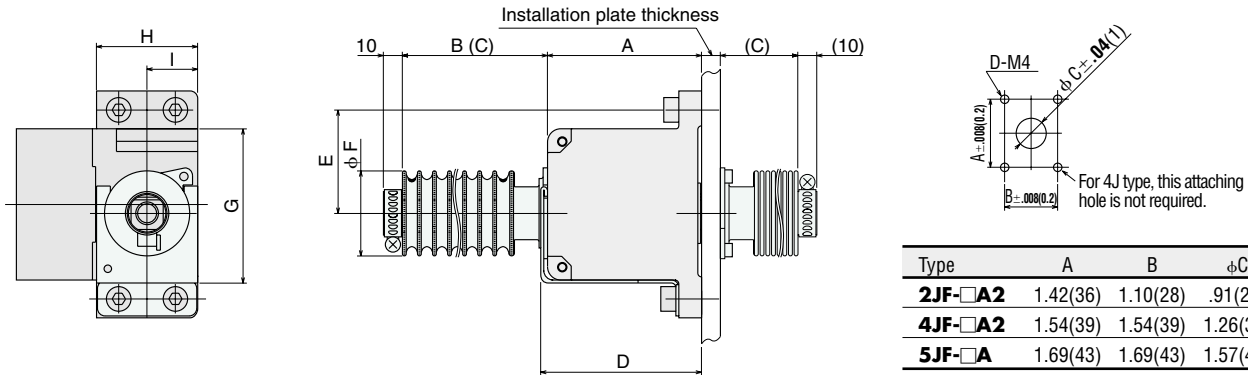

| Type | A | B | ϕC | D |
|----------------|----------|----------|----------|---|
| 2JF-□A2 | 1.42(36) | 1.10(28) | .91(23) | 4 |
| 4JF-□A2 | 1.54(39) | 1.54(39) | 1.26(32) | 3 |
| 5JF-□A | 1.69(43) | 1.69(43) | 1.57(40) | 4 |

Material

Rack cover: Nylon

Installation fittings: SPCC

Accessories: Installation fittings, stainless steel band

Note:

- When a rack cover is installed, the effective rack stroke is shortened. Refer to the table below for the operable stroke.
- The installation fittings are fastened together with the main unit using the screws (sold separately) : **2JF** type: M6; **4JF** type: M8; **5JF** type: M10
- When installing the linear head fixed side rack cover, drill installation holes in the linear head installation plate using the diagram on the right for reference, then fasten with screws at the rack cover flange. Screws must be purchased separately.

Unit = inch (mm)

| Model | Applicable Linear Head | A | For single side rack cover | | For both sides rack covers* | | D | E | F | G | H (Fitting width) | I |
|----------------|------------------------|----------------|----------------------------|-----------------|-----------------------------|-----------------|----------------|----------------|--------------|----------------|-------------------------|----------------|
| | | | B | Operable stroke | (C) | Operable stroke | | | | | | |
| 2JF-1A2 | 2LF□N-1 | 2.61 (66.3) | .98~3.94 (25~100) | 2.95 (75) | .98~2.52 (25~64) | 1.54 (39) | 2.76 (70) | 1.47 (37.3) | 1.65 (42) | 2.41 (61.2) | 1.57 (40) | .79 (20) |
| 2JF-2A2 | 2LF□N-2 | | 1.57~7.87 (40~200) | 6.3 (160) | 1.57~5.51 (40~140) | 3.94 (100) | | | | | | |
| 2JF-3A2 | 2LF□N-3 | | 2.36~11.81 (60~300) | 9.45 (240) | 2.36~8.66 (60~220) | 6.3 (160) | | | | | | |
| 4JF-1A2 | 4LF□N-1 | 3.23 (82) | 1.57~3.94 (40~100) | 2.36 (60) | 1.57~1.89 (40~48) | .31 (8) | 3.38 (85.9) | 2.15 (54.7) | 1.77 (45) | 3.21 (81.6) | 2.11 (53.6) | 1.06 (26.8) |
| 4JF-2A2 | 4LF□N-2 | | 2.17~7.87 (55~200) | 5.71 (145) | 2.17~5.31 (55~135) | 3.15 (80) | | | | | | |
| 4JF-3A2 | 4LF□N-3 | | 2.36~11.81 (60~300) | 9.45 (240) | 2.36~8.98 (60~228) | 6.61 (168) | | | | | | |
| 4JF-4A2 | 4LF□N-4 | | 3.15~15.75 (80~400) | 12.6 (320) | 3.15~12.30 (80~310) | 9.06 (230) | | | | | | |
| 4JF-5A2 | 4LF□N-5 | | 3.94~19.69 (100~500) | 15.75 (400) | 3.94~15.31 (100~389) | 11.38 (289) | | | | | | |
| 5JF-1A | 5LF□N(U)-1 | 3.74 (95) | .98~3.94 (25~100) | 2.95 (75) | 1.26~3.94 (32~100) | 2.68 (68) | 3.9 (99.1) | 2.48 (63.1) | 1.77 (45) | 3.61 (91.6) | 2.13 (54) | 1.18 (30) |
| 5JF-2A | 5LF□N(U)-2 | | 1.57~7.87 (40~200) | 6.3 (160) | 1.57~7.60 (40~193) | 6.02 (153) | | | | | | |
| 5JF-3A | 5LF□N(U)-3 | | 2.36~11.81 (60~300) | 9.45 (240) | 2.36~10.75 (60~273) | 8.39 (213) | | | | | | |
| 5JF-4A | 5LF□N(U)-4 | | 3.15~15.75 (80~400) | 12.6 (320) | 3.15~13.94 (80~354) | 10.79 (274) | | | | | | |
| 5JF-5A | 5LF□N(U)-5 | | 3.94~19.69 (100~500) | 15.75 (400) | 3.94~17.09 (100~434) | 13.15 (334) | | | | | | |

* When rack covers are used on both sides, the "operable stroke" and "C" are values when a 0.39inch (10mm) thick installation is used.

B type

● Dimensions Unit = inch (mm)

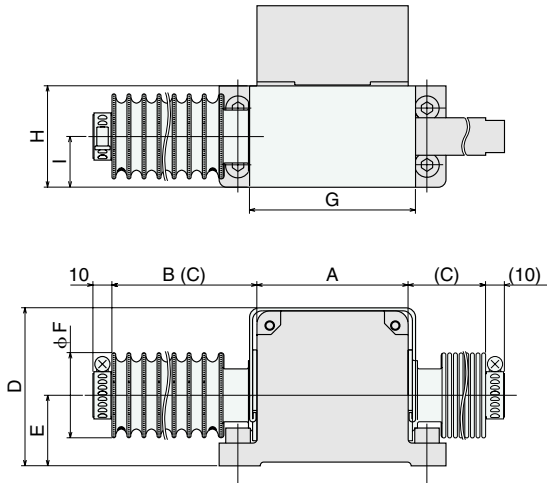

Material
 Rack cover: Nylon
 Installation fittings: SPCC
 Accessories: Installation fittings, Plugs,
 stainless steel band

Notes:
 When rack covers are installed on both sides of the rack a supplemental rack cover must also be purchased.

Unit = inch (mm)

| Model | Applicable Linear Head | A | For single side rack cover | | For both sides rack covers* | | D | E | F | G | H (Fitting width) | I |
|----------------|------------------------|--------------|----------------------------|-----------------|-----------------------------|-----------------|----------------|----------------|--------------|----------------|-------------------------|----------------|
| | | | B | Operable stroke | (C) | Operable stroke | | | | | | |
| 2JB-1A2 | 2LB□N-1 | 2.36 (66) | .98~3.94 (25~100) | 2.95 (75) | .98~2.76 (25~70) | 1.77 (45) | 2.66 (67.5) | 1.42 (36) | 1.65 (42) | 2.67 (67.9) | 1.57 (40) | .79 (20) |
| 2JB-2A2 | 2LB□N-2 | | 1.57~7.87 (40~200) | 6.3 (160) | 1.57~4.57 (40~116) | 2.99 (76) | | | | | | |
| 2JB-3A2 | 2LB□N-3 | | 2.36~11.81 (60~300) | 9.45 (240) | 2.36~9.33 (60~237) | 6.97 (177) | | | | | | |
| 4JB-1A2 | 4LB□N-1 | 3.15 (80) | 1.57~3.94 (40~100) | 2.36 (60) | 1.57~2.36 (40~60) | .79 (20) | 3.29 (83.6) | 1.47 (37.3) | 1.77 (45) | 3.46 (87.8) | 2.11 (53.6) | 1.06 (26.8) |
| 4JB-2A2 | 4LB□N-2 | | 2.17~7.87 (55~200) | 5.71 (145) | 2.17~5.79 (55~147) | 3.62 (92) | | | | | | |
| 4JB-3A2 | 4LB□N-3 | | 2.36~11.81 (60~300) | 9.45 (240) | 2.36~9.45 (60~240) | 7.09 (180) | | | | | | |
| 4JB-4A2 | 4LB□N-4 | | 3.15~15.75 (80~400) | 12.6 (320) | 3.15~12.68 (80~322) | 9.53 (242) | | | | | | |
| 4JB-5A2 | 4LB□N-5 | | 3.94~19.69 (100~500) | 15.75 (400) | 3.94~15.79 (100~401) | 11.85 (301) | | | | | | |
| 5JB-1A | 5LB□N(U)-1 | 3.54 (90) | .98~3.94 (25~100) | 2.95 (75) | 1.85~3.94 (47~100) | 2.05 (52) | 3.8 (96.6) | 2.17 (55.2) | 1.77 (45) | 3.89 (98.7) | 2.13 (54) | 1.18 (30) |
| 5JB-2A | 5LB□N(U)-2 | | 1.57~7.87 (40~200) | 6.3 (160) | 1.89~7.87 (40~200) | 5.94 (151) | | | | | | |
| 5JB-3A | 5LB□N(U)-3 | | 2.36~11.81 (60~300) | 9.45 (240) | 2.36~11.34 (60~288) | 8.98 (228) | | | | | | |
| 5JB-4A | 5LB□N(U)-4 | | 3.15~15.75 (80~400) | 12.6 (320) | 3.15~14.53 (80~369) | 11.38 (289) | | | | | | |
| 5JB-5A | 5LB□N(U)-5 | | 3.94~19.69 (100~500) | 15.75 (400) | 3.94~17.68 (100~449) | 13.74 (349) | | | | | | |

* When rack covers are used on both sides, the "operable stroke" and "C" are values when a 0.39inch (10mm) thick installation is used.

■ Supplemental rack cover

When rack covers are installed on both sides of the rack, a supplemental rack cover must also be purchased.

● Rack Cover Dimensions Unit = inch (mm)

For **2L** type

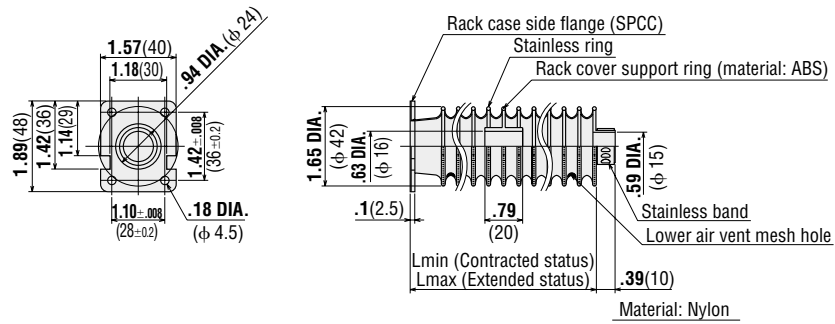

| Model | L max (Extended status) | L min (Contracted status) | Number of support rings | Compression Ratio | Weight (Mass) lb. (kg) |
|---------------|----------------------------|------------------------------|-------------------------|-------------------|---------------------------|
| 2J-1A2 | 3.94 (100) | .98 (25) | 0 | 1/4 | 0.099 (0.045) |
| 2J-2A2 | 7.87 (200) | 1.57 (40) | 1 | 1/5 | 0.132 (0.060) |
| 2J-3A2 | 11.81 (300) | 2.36 (60) | 1 | 1/5 | 0.154 (0.070) |

For **4L** type

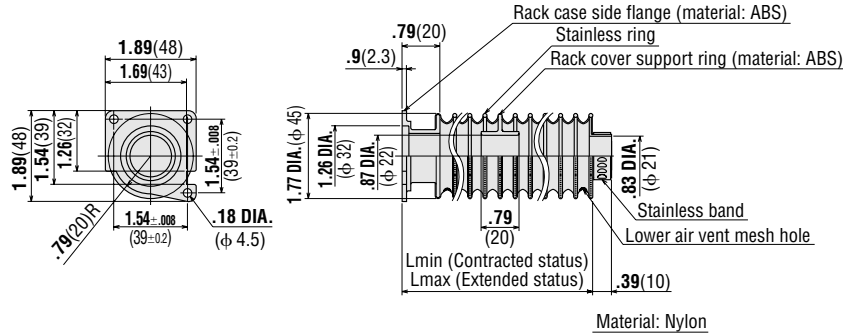

| Model | L max (Extended status) | L min (Contracted status) | Number of support rings | Compression Ratio | Weight (Mass) lb. (kg) |
|---------------|----------------------------|------------------------------|-------------------------|-------------------|---------------------------|
| 4J-1A2 | 3.94 (100) | 1.57 (40) | 0 | 1/2.5 | 0.066 (0.030) |
| 4J-2A2 | 7.87 (200) | 2.17 (55) | 1 | 1/3.6 | 0.099 (0.045) |
| 4J-3A2 | 11.81 (300) | 2.36 (60) | 1 | 1/5 | 0.121 (0.055) |
| 4J-4A2 | 15.75 (400) | 3.15 (80) | 2 | 1/5 | 0.154 (0.070) |
| 4J-5A2 | 19.69 (500) | 3.94 (100) | 3 | 1/5 | 0.198 (0.090) |

For **5L** type

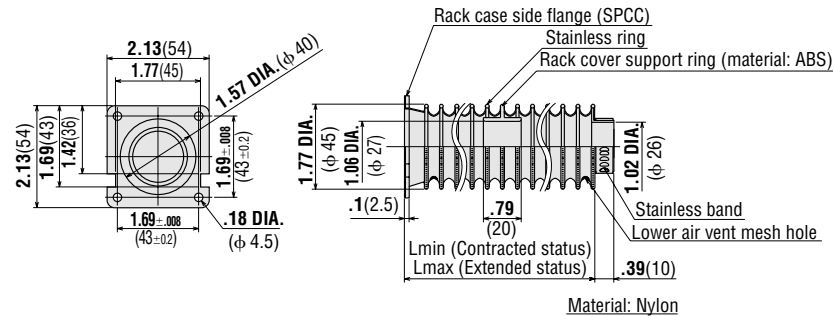

| Model | L max (Extended status) | L min (Contracted status) | Number of support rings | Compression Ratio | Weight (Mass) lb. (kg) |
|--------------|----------------------------|------------------------------|-------------------------|-------------------|---------------------------|
| 5J-1A | 3.94 (100) | .98 (25) | 0 | 1/4 | 0.110 (0.050) |
| 5J-2A | 7.87 (200) | 1.57 (40) | 1 | 1/5 | 0.154 (0.070) |
| 5J-3A | 11.81 (300) | 2.36 (60) | 1 | 1/5 | 0.176 (0.080) |
| 5J-4A | 15.75 (400) | 3.15 (80) | 2 | 1/5 | 0.209 (0.095) |
| 5J-5A | 19.69 (500) | 3.94 (100) | 3 | 1/5 | 0.253 (0.115) |

ORIENTAL MOTOR GENERAL CATALOG



Accessories

| | |
|---|-------|
| Flexible Couplings | A-260 |
| Motor Mounting Brackets | A-266 |
| External Speed Indicators | A-269 |
| External Speed Potentiometers | A-269 |
| Extension Cables | A-270 |
| Mounting Bracket for DIN Rail | A-271 |
| CR Circuit for Surge Suppression | A-272 |
| Power Relay Box | A-272 |
| Extension Cables for Splashproof Motors | A-272 |
| Dog | A-273 |

Induction Motors

Reversible Motors

Synchronous Motors

Torque Motors

FBL II

HBL

SC

US

Component

Magnetic Brake

Clutch & Brake

Washdown Motors

Gearheads

Linear Heads

Accessories

Speed Control Motors

Brake Motors

■ FLEXIBLE COUPLING

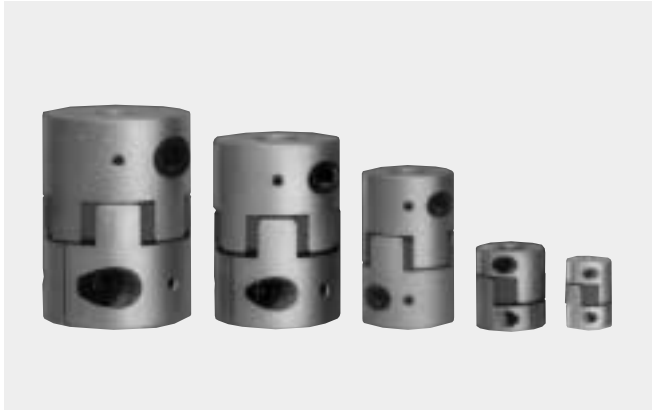

Features

- Couplings come with shaft holes and have standardized combinations for different diameter shaft holes.
- Characteristics are the same for clockwise and counterclockwise.
- Oil-resistant and electrically insulated.
- Aluminum alloy construction.
- The shaft being driven is not damaged, since shafts are joined by clamping.
- Easy installation to a separated hub and sleeve design.

● Selecting a Flexible Coupling

Once you have decided on a motor and the shaft diameter of the equipment to be connected to it, select the proper flexible coupling to use. Oriental Motor's flexible couplings are available in external diameter sizes that provide the strength required for the motor torque.

Example **MCL 30 F06 F06**
 Inner Diameter d1 Inner Diameter d2

When the motor is a **4GN□KA** (shaft outer diameter of .375inch) and the shaft diameter of the equipment to be connected to the motor is .375inch, use an **MCL30F06F06**.

● Product Number Code

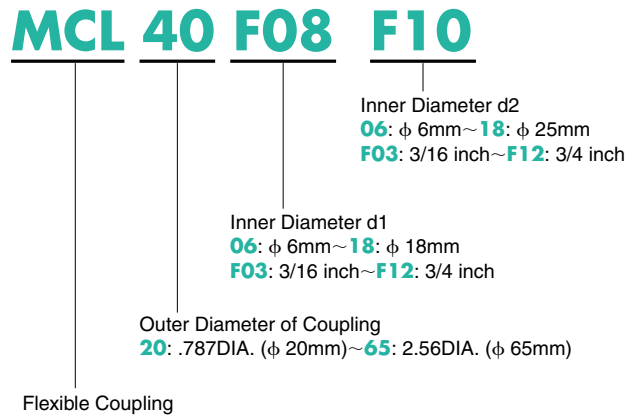

| Coupling Type | Shaft Diameter | | Gearhead Model* | | Connected Device Shaft Diameter | | | | | | | |
|---------------|----------------|--------|-----------------|--|-----------------------------------|---------------------|----------------------|---------------------|---------------------|----------------------|----------------------|--|
| | inch | mm. | Regular Load | Shock Load | F03 | F04 | F05 | F06 | F08 | F10 | F12 | |
| | | | | | 3/16inch φ4.763mm | 1/4inch φ6.350mm | 5/16inch φ7.938mm | 3/8inch φ9.525mm | 1/2inch φ12.70mm | 5/8inch φ15.875mm | 3/4inch φ19.050mm | |
| MCL20 | F03 | 3/16 | 4.763 | OGN□KA | OGN□KA | ○ | ○ | ○ | ○ | | | |
| | 06 | 0.236 | 6 | | | ○ | ○ | ○ | ○ | | | |
| | F04 | 1/4 | 6.350 | 2GB□KA | 2GB□KA | ○ | ○ | ○ | ○ | | | |
| | F05 | 5/16 | 7.938 | 2GN□KA | | ○ | ○ | ○ | ○ | | | |
| | 08 | 0.315 | 8 | | | | ○ | ○ | ○ | | | |
| MCL30 | F05 | 5/16 | 7.938 | 4GB□KA | 2GN□KA, 4GB□KA | | ○ | ○ | ○ | ○ | | |
| | 08 | 0.315 | 8 | | | | ○ | ○ | ○ | ○ | | |
| | F06 | 3/8 | 9.525 | 3GN□KA, 4GN□KA, 5GN□RAA | 3GN□KA | | | ○ | ○ | ○ | | |
| | 10 | 0.394 | 10 | FPW425_□ | | | | ○ | ○ | ○ | | |
| | 12 | 0.472 | 12 | FPW540_□ | | | | ○ | ○ | ○ | | |
| | F08 | 1/2 | 12.70 | 5GN□KA | | | | ○ | ○ | | | |
| MCL40 | F06 | 3/8 | 9.525 | | 4GN□KA, 5GN□RAA | | | | ○ | ○ | | |
| | 10 | 0.394 | 10 | | FPW425_□ | | | ○ | ○ | ○ | | |
| | 12 | 0.472 | 12 | | FPW540_□ | | | ○ | ○ | ○ | | |
| | F08 | 1/2 | 12.70 | | 5GN□KA, 5GC□KA | | | | ○ | ○ | | |
| | 14 | 0.551 | 14 | | | | | ○ | ○ | ○ | | |
| | 15 | 0.591 | 15 | FPW560_□ | | | | | | ○ | | |
| | F10 | 5/8 | 15.875 | 5GU□KA, 5GU□RAA | | | | | | ○ | | |
| MCL55 | 15 | 0.591 | 15 | | FPW560_□ | | | | | ○ | ○ | |
| | F10 | 5/8 | 15.875 | | 5GU□KA, 5GU□RAA, 5GC□KA | | | | | ○ | ○ | |
| | 18 | 0.7087 | 18 | FBL575, 5120_□, HBL560, 5100N_□ FPW690_□, BHI62_□ | FBL575, 5120_□ HBL560, 5100N_□ | | | | | ○ | ○ | |
| MCL65 | 15 | 0.591 | 15 | | | | | | | ○ | ○ | |
| | 18 | 0.7087 | 18 | | FPW690_□, BHI62_□ | | | | | ○ | ○ | |

* It is also available for round shaft motors.

● Mounting on a shaft

The **MCL** Couplings are clamp type for mounting the flexible coupling to the shaft.

Clamp Type

Clamp type couplings use the binding force of the screw to compress the axis hole diameter and thereby fasten the coupling to the shaft. This does not damage the shaft and is easy to mount and remove. The following table shows the screw tightening torque.

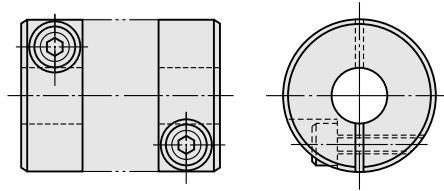

| Type | | *MCL20 | MCL30 | MCL40 | MCL55 | MCL65 |
|--------------------------------------|-------|--------|-------|-------|-------|-------|
| Tightening Torque | lb-in | 8.7 | 21.7 | 104 | 217 | 434 |
| | (N·m) | (1) | (2.5) | (12) | (25) | (50) |
| Tightening Torque of key press screw | lb-in | 6.1 | 14.8 | 14.8 | 14.8 | 34.7 |
| | (N·m) | (0.7) | (1.7) | (1.7) | (1.7) | (4) |

*MCL20 type uses a set screw.

■ Alignment Adjustment

Flexible couplings tolerate misalignment of the axis center and transfer rotational angle and torque, but produce vibration when the permissible value for misalignment is exceeded. This can dramatically shorten the coupling's service life.

Misalignment of the axis center includes eccentricity (parallel error of both centers), declination (angular error of both centers) and end play (shaft movement in the axial direction). To keep misalignment to within the permissible value, always check and adjust the alignment. To increase the service life of the coupling, we recommend keeping misalignment to below 1/3 of the permissible value.

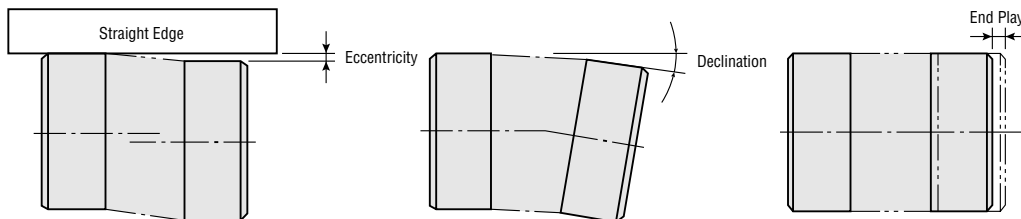

NOTE:

- Misalignment or excessive torque beyond the permissible values will deform the coupling and shorten its service life.
- If you hear a strange metallic noise from the coupling while it is running, stop the motor immediately and check for misalignment, shaft interference, loose screws, or the like.
- When load fluctuates substantially, paint adhesive over the screws or switch to a larger coupling diameter. This helps prevent coupling screws from coming loose.
- When using couplings that have no key grooves, as on the **MCL20**, **MCL30**, **MCL40** and **MCL55** fasten clamping screws before fastening set screws.
- Only use the screws specified by Oriental Motor. Other screws may damage the couplings.
- Using couplings at speeds beyond their maximum rated speed can damage couplings and harm other equipment. Never operate beyond the maximum rated speed.
- Do not bring fingers or hands into contact with an operating coupling as injury may result. Always use protective covers to prevent accidents. Also, install safety systems that stop coupling as soon as the protective cover is opened.
- Always be sure the power is off during installation. Should the drive unit accidentally start running, injury can occur by being drawn into the device. Always check that the device's main power supply is off before performing installation work.

● Specifications

| Model | Dimensions | | | | Average Torque lb.in (N.m) | Mass oz (kg) | Moment of Inertia lb-in ² (kg-m ²) | Permissible Eccentricity inch (mm) | Permissible Declination degrees | Permissible End Play inch (mm) | | | | | | | |
|--------------------|-----------------------------------|------------------------|-------------------------------------|-------------------------------------|----------------------------------|-------------------------------------|--|---|---------------------------------------|---|---------------|---------------|-------------------|------------------------------------|--|--|--|
| | Outer Diameter inch (mm) | Length inch (mm) | Bore Diameter d1 inch (mm) | Bore Diameter d2 inch (mm) | | | | | | | | | | | | | |
| MCL20F03F03 | 0.787 (φ20) | 1.14 (29) | .1875 (4.763) | .1875 (4.763) | 43 (5) | 0.671 (19×10 ⁻³) | 3.4×10 ⁻³ (1.0×10 ⁻⁶) | 5.9×10 ⁻³ 0.15 | | +0.0315 0 (+0.8 0) | | | | | | | |
| MCL20F03F04 | | | | .250 (6.35) | | | | | | | | | | | | | |
| MCL20F03F05 | | | | .3125 (7.938) | | | | | | | | | | | | | |
| MCL2006F03 | | | .2362 (6) | | | | | | | | .1875 (4.763) | | | | | | |
| MCL2006F04 | | | | | | | | | | | .250 (6.35) | | | | | | |
| MCL2006F05 | | | | | | | | | | | .3125 (7.938) | | | | | | |
| MCL20F04F04 | | | | | | | | | | | .250 (6.35) | | | | | | |
| MCL20F04F05 | | | | | | | | | | | .3125 (7.938) | | | | | | |
| MCL20F05F05 | | | | | | | | | | | .3125 (7.938) | | | | | | |
| MCL2008F04 | | | | | | | | | | | .250 (6.35) | | | | | | |
| MCL2008F05 | | | | | | | | | | | .3125 (7.938) | | | | | | |
| MCL30F04F05 | | | 1.18 (φ30) | 1.71 (43.5) | | | | | | | .250 (6.35) | .3125 (7.938) | 107 (12.5) | 2.33 (66×10 ⁻³) | 28.4×10 ⁻³ (8.3×10 ⁻⁶) | | |
| MCL30F05F05 | .3125 (7.938) | | | | | | | | | | | | | | | | |
| MCL30F05F06 | .3750 (9.525) | | | | | | | | | | | | | | | | |
| MCL3008F06 | .3150 (8) | | | | .3750 (9.525) | | | | | | | | | | | | |
| MCL30F06F06 | | | | | .3750 (9.525) | | | | | | | | | | | | |
| MCL30F06F08 | | | | | .500 (12.7) | | | | | | | | | | | | |
| MCL3010F05 | | | | | .3125 (7.938) | | | | | | | | | | | | |
| MCL3010F06 | | | | | .3750 (9.525) | | | | | | | | | | | | |
| MCL3010F08 | | | | | .500 (12.7) | | | | | | | | | | | | |
| MCL3012F06 | | | | | .3750 (9.525) | | | | | | | | | | | | |
| MCL3012F08 | | | | | .500 (12.7) | | | | | | | | | | | | |
| MCL30F08F08 | | | | | .500 (12.7) | .500 (12.7) | | | | | | | | | | | |
| MCL40F05F06 | | | .3125 (7.938) | | | | | | | | | | | | | | |
| MCL40F06F06 | | | .3750 (9.525) | | | | | | | | | | | | | | |
| MCL40F06F08 | | | | | .500 (12.7) | | | | | | | | | | | | |
| MCL4010F05 | | | | | .3125 (7.938) | | | | | | | | | | | | |
| MCL4010F06 | | | | | .3750 (9.525) | | | | | | | | | | | | |
| MCL4010F08 | | | | | .500 (12.7) | | | | | | | | | | | | |
| MCL4012F06 | | | | | .3750 (9.525) | | | | | | | | | | | | |
| MCL4012F08 | | | | | .500 (12.7) | | | | | | | | | | | | |
| MCL4012F10 | | | | | .625 (15.875) | | | | | | | | | | | | |
| MCL40F08F08 | | | | | .500 (12.7) | | | | | | | | | | | | |
| MCL40F08F10 | | | | | .500 (12.7) | .3750 (9.525) | | | | | | | | | | | |
| MCL4014F06 | .500 (12.7) | | | | | | | | | | | | | | | | |
| MCL4014F08 | .625 (15.875) | | | | | | | | | | | | | | | | |
| MCL4014F10 | | | .5512 (14) | .3750 (9.525) | | | | | | | | | | | | | |
| MCL4015F08 | | | | .500 (12.7) | | | | | | | | | | | | | |
| MCL4015F10 | | | | .625 (15.875) | | | | | | | | | | | | | |
| MCL40F10F10 | | | .625 (15.875) | .625 (15.875) | | | | | | | | | | | | | |
| MCL5515F08 | | | | .500 (12.7) | | | | | | | | | | | | | |
| MCL5515F10 | 2.17 (φ55) | 2.99 (76) | .5906 (15) | .625 (15.875) | 512 (60) | 12.4 (350×10 ⁻³) | 547×10 ⁻³ (160×10 ⁻⁶) | | | +0.0551 0 (+1.4 0) | | | | | | | |
| MCL5515F12 | | | | .750 (19.05) | | | | | | | | | | | | | |
| MCL55F10F10 | | | | .625 (15.875) | | | | | | | | | | | | | |
| MCL55F10F12 | | | | .625 (15.875) | | | | | | | | | | | | | |
| MCL5518F10 | | | | .750 (19.05) | | | | | | | | | | | | | |
| MCL5518F12 | | | | .7087 (18) | | | | | | | | | | | | | |
| MCL6518F10 | | | | .750 (19.05) | | | | | | | | | | | | | |
| MCL6518F12 | 2.56 (φ65) | 3.44 (87.5) | .7087 (18) | .750 (19.05) | 1365 (160) | 20.1 (570×10 ⁻³) | 1264×10 ⁻³ (370×10 ⁻⁶) | | | +0.0591 0 (+1.5 0) | | | | | | | |

● Dimensions Unit = inch (mm)

MCL20

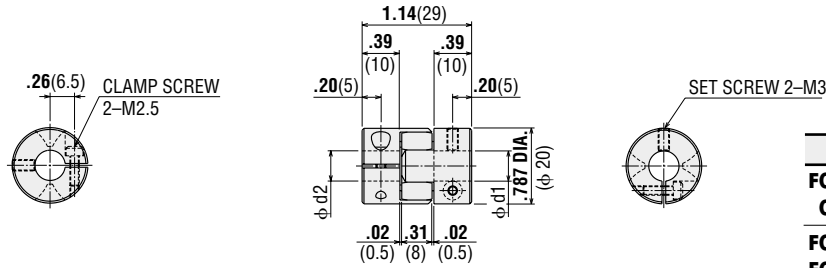

| BORE (φ d1, φ d2) | TOLERANCE |
|----------------------------------|-------------------------|
| F03 : .1875DIA. (φ 4.763) | +0.0071 (+0.018) |
| O6 : .2362DIA. (φ 6) | 0 (0) |
| F04 : .2500DIA. (φ 6.35) | +0.0087 (+0.022) |
| F05 : .3125DIA. (φ 7.938) | 0 (0) |
| O8 : .3150DIA. (φ 8) | 0 (0) |

MCL30

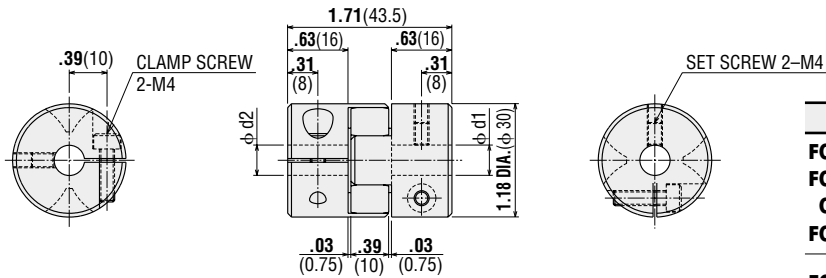

| BORE (φ d1, φ d2) | TOLERANCE |
|----------------------------------|-------------------------|
| F04 : .2500DIA. (φ 6.350) | +0.0087 (+0.022) |
| F05 : .3125DIA. (φ 7.938) | 0 (0) |
| O8 : .3150DIA. (φ 8) | 0 (0) |
| F06 : .3750DIA. (φ 9.525) | 0 (0) |
| F08 : 0.500DIA. (φ 12.7) | +0.0106 (+0.027) |
| | 0 (0) |

MCL3010F05
MCL3010F06
MCL3010F08
MCL3012F06
MCL3012F08

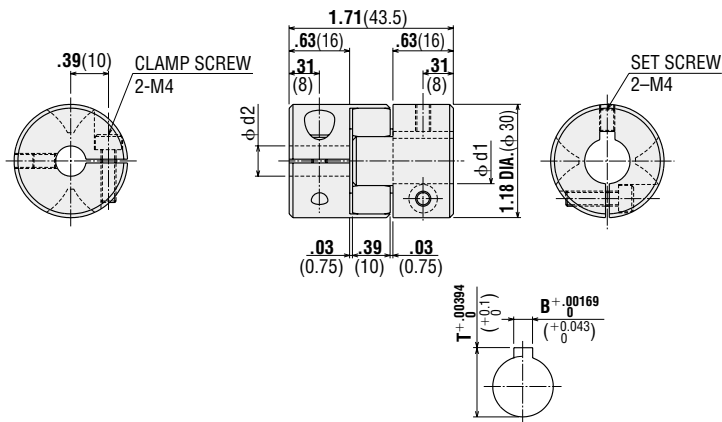

| BORE (φ d1) | TOLERANCE | WIDTH:B | LENGTH:T |
|------------------------------|-------------------------|--------------|--------------|
| 10 : .3937DIA. (φ 10) | +0.0087 (+0.022) | .1575 | .4645 (11.8) |
| 12 : .4724DIA. (φ 12) | +0.0106 (+0.027) | | .5433 (13.8) |
| | 0 (0) | (4) | |

| BORE (φ d2) | TOLERANCE |
|----------------------------------|-------------------------|
| F05 : .3125DIA. (φ 7.938) | +0.0087 (+0.022) |
| F06 : .3750DIA. (φ 9.525) | 0 (0) |
| F08 : .500DIA. (φ 12.7) | +0.0106 (+0.027) |
| | 0 (0) |

MCL40F05F06
MCL40F06F06
MCL40F06F08
MCL40F08F08

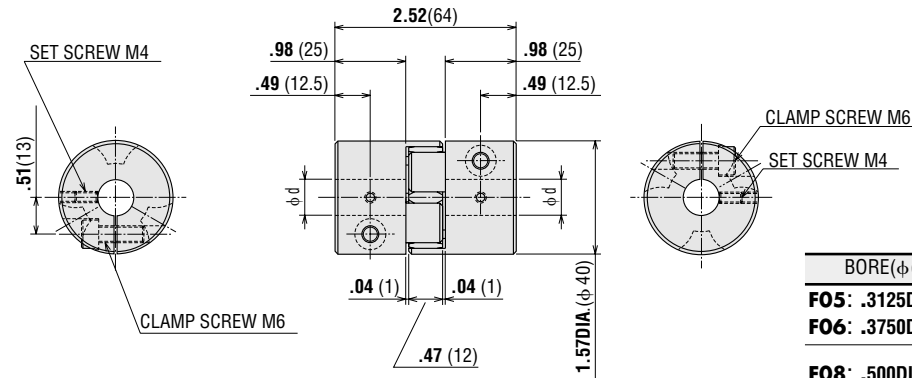

| BORE (φ d1, φ d2) | TOLERANCE |
|----------------------------------|-------------------------|
| F05 : .3125DIA. (φ 7.938) | +0.0087 (+0.022) |
| F06 : .3750DIA. (φ 9.525) | 0 (0) |
| F08 : .500DIA. (φ 12.7) | +0.0106 (+0.027) |
| | 0 (0) |

MCL4010F05
MCL4010F06
MCL4010F08
MCL4012F06
MCL4012F08
MCL40F08F10
MCL4014F06
MCL4014F08
MCL4015F08

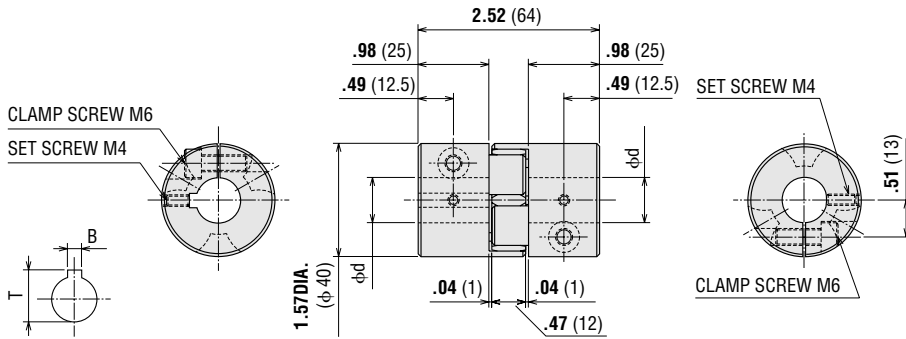

| BORE (φd1) | TOLERANCE | WIDTH: B | TOLERANCE | LENGTH: T | TOLERANCE |
|------------------------------------|--|---|--|--|--|
| 10: .3937DIA. (φ10) | +.00087 0 (+0.022) (0) | .1575 (4) | +.00169 0 (+0.043) (0) | .4645 (11.8) | +.00394 0 (+0.1) (0) |
| 12: .4724DIA. (φ12) | +.00106 0 (+0.027) (0) | | | .5433 (13.8) | |
| 14: .5512DIA. (φ14) | | | | .6417 (16.3) | |
| 15: .5906DIA. (φ15) | | | | .6811 (17.3) | |
| F10: .6250DIA. (φ15.875) | .1875 (4.763) | +.0020 0 (+0.051) (0) | .7090 (18.009) | +.010 0 (+0.254) (0) | |

| BORE (φd2) | TOLERANCE |
|--------------------------------|--|
| F05: .3125DIA. (φ7.938) | +.00087 0 (+0.022) (0) |
| F06: .3750DIA. (φ9.525) | +.00106 0 (+0.027) (0) |
| F08: .5000DIA. (φ12.7) | +.00106 0 (+0.027) (0) |

MCL4012F10
MCL4014F10
MCL4015F10
MCL40F10F10

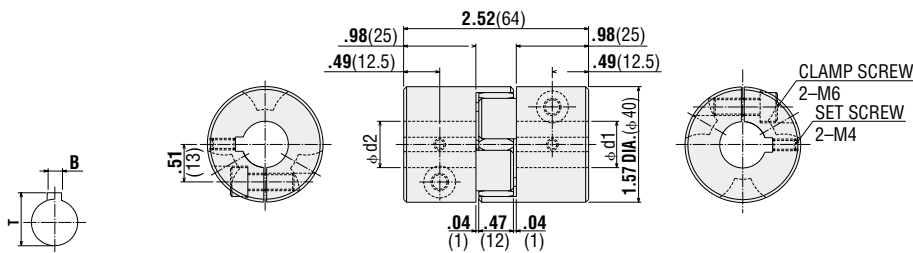

| BORE (φd1) | TOLERANCE | WIDTH: B | TOLERANCE | LENGTH: T | TOLERANCE |
|------------------------------------|--|---|--|--|--|
| 10: .3937DIA. (φ10) | +.00087 0 (+0.022) (0) | .1575 (4) | +.00169 0 (+0.043) (0) | .4645 (11.8) | +.00394 0 (+0.1) (0) |
| 12: .4724DIA. (φ12) | +.00106 0 (+0.027) (0) | | | .5433 (13.8) | |
| 14: .5512DIA. (φ14) | | | | .6417 (16.3) | |
| 15: .5906DIA. (φ15) | | | | .6811 (17.3) | |
| F10: .6250DIA. (φ15.875) | .1875 (4.763) | +.0020 0 (+0.051) (0) | .7090 (18.009) | +.010 0 (+0.254) (0) | |

MCL5515F08

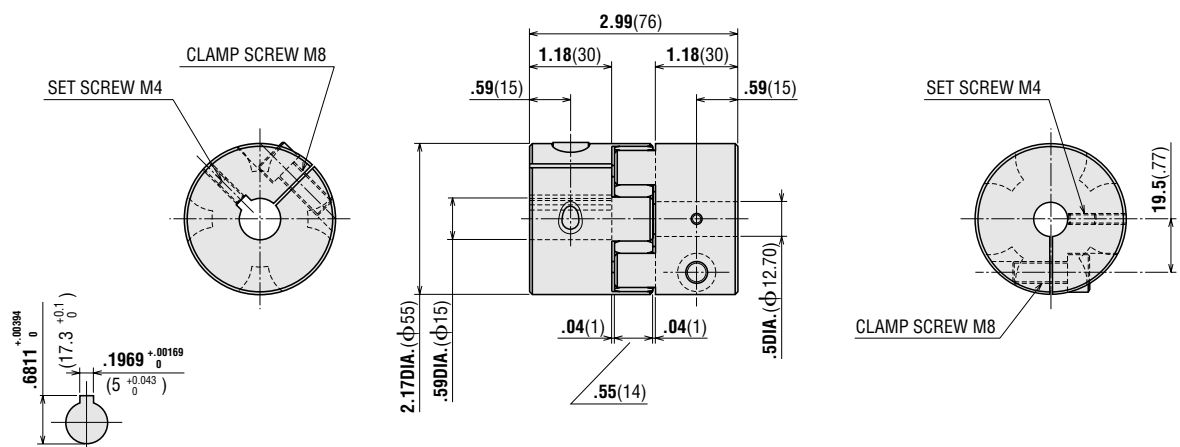

MCL55

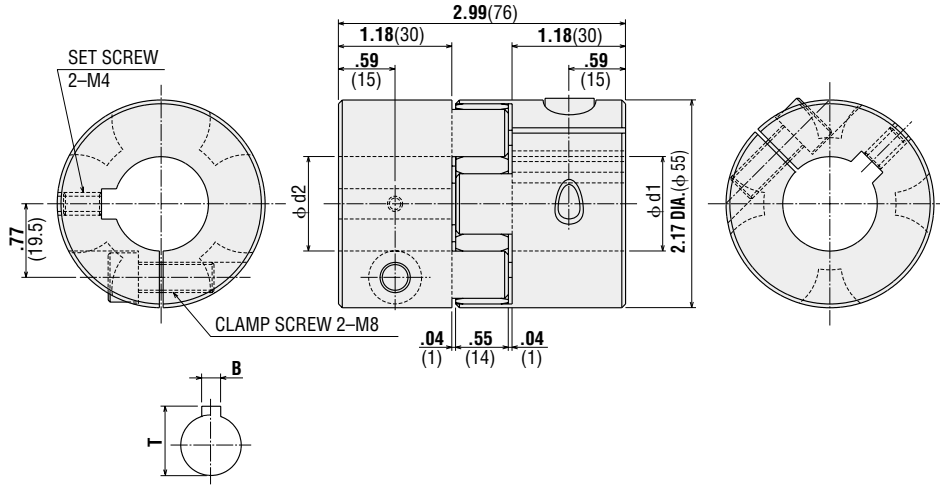

| BORE ($\phi d1, \phi d2$) | WIDTH: B | TOLERANCE | LENGTH: T | TOLERANCE |
|--|-------------------------|---|--------------------------|---------------------------------------|
| 15: .5906DIA. ($\phi 15$) | .1969 (5) | +.00169 (+0.043) 0 (0) | .6811 (17.3) | +.00394 (+0.1) 0 (0) |
| 18: .7087DIA. ($\phi 18$) | .2362 (6) | +.00205 (+0.052) 0 (0) | .8189 (20.8) | +.00394 (+0.1) 0 (0) |
| F10: .6250DIA. ($\phi 15.875$) | .1875 (4.763) | +.002 (+0.051) 0 (0) | .7090 (18.009) | +.01 (+0.254) 0 (0) |
| F12: .7500DIA. ($\phi 19.050$) | .1875 (4.763) | +.002 (+0.051) 0 (0) | .8370 (21.260) | +.01 (+0.254) 0 (0) |

MCL65

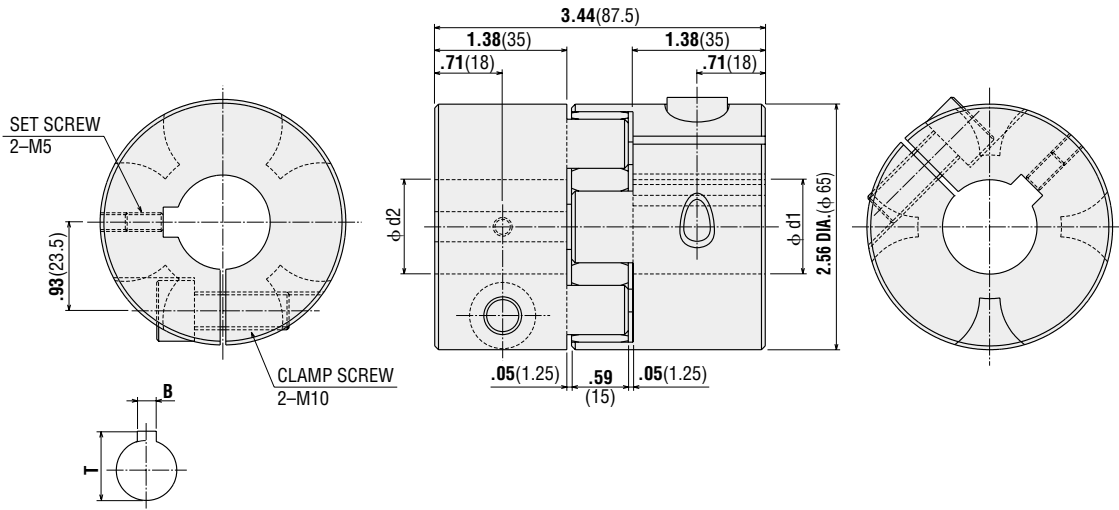

| BORE ($\phi d1, \phi d2$) | WIDTH: B | TOLERANCE | LENGTH: T | TOLERANCE |
|--|-------------------------|---|--------------------------|---------------------------------------|
| 18: .7087DIA. ($\phi 18$) | .2362 (6) | +.00205 (+0.052) 0 (0) | .8189 (20.8) | +.00394 (+0.1) 0 (0) |
| F10: .6250DIA. ($\phi 15.875$) | .1875 (4.763) | +.002 (+0.051) 0 (0) | .7090 (18.009) | +.01 (+0.254) 0 (0) |
| F12: .7500DIA. ($\phi 19.050$) | .1875 (4.763) | +.002 (+0.051) 0 (0) | .8370 (21.260) | +.01 (+0.254) 0 (0) |

■ Motor Mounting Brackets



Five kinds of mounting brackets for motors and gearheads are available as shown below. These brackets come with tapped holes. To mount the motor and gearhead, simply fasten with the screws provided with gearhead.

Please note that these mounting brackets cannot be used with the right-angle gearheads and flange mounting (**5GC□KA** and **5GCH□KA**).

● Dimensions Scale 1/4 Unit = inch (mm)

For 1.65 in. sq. (42mm sq.)

Model: **SOL0U04**

Weight: 2.8oz(80g) Material: Aluminium

Compatible Motor and Gearhead

● **0GN□KA**

- 1.65 in sq.(42mm sq.) frame size motors

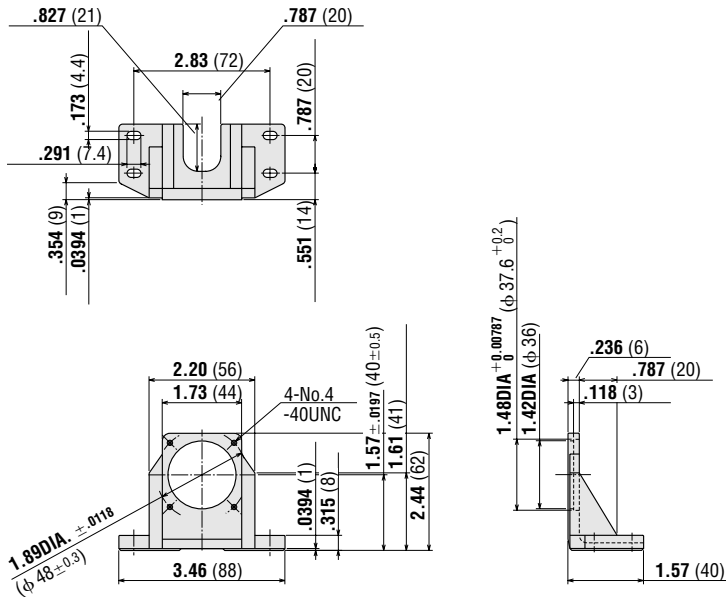

For 2.36 in. sq. (60mm sq.)

Model: **SOL2Uφ8**

Weight: 4.2oz(120g) Material: Aluminium

Compatible Motor and Gearhead

● **2GN□KA**

- 2.36 in sq.(60mm sq.) frame size motors

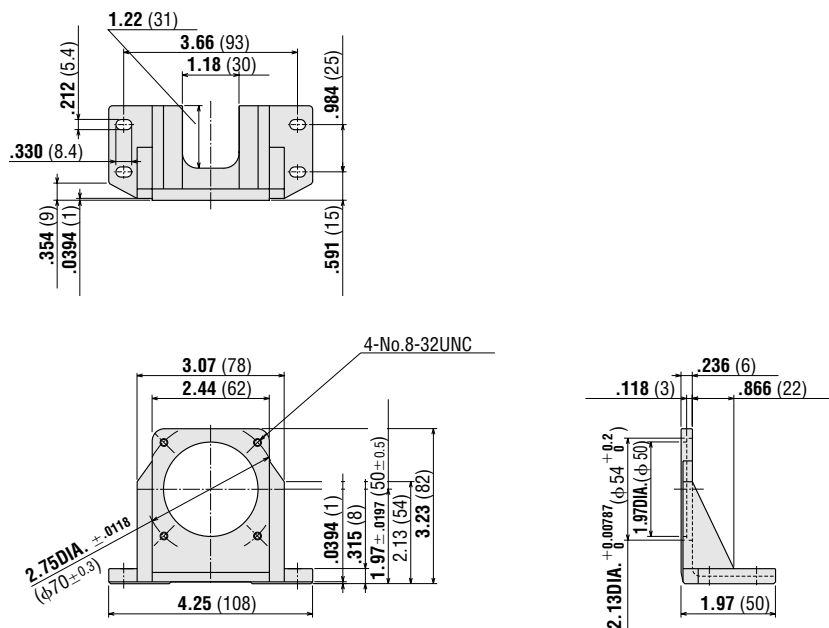

For 2.76 in. sq. (70mm sq.)

Model: **SOL3U10**
 Weight: 5.6oz(160g) Material: Aluminium

Compatible Motor and Gearhead

- **3GN□KA**
- 2.76 in sq.(70mm sq.) frame size motors

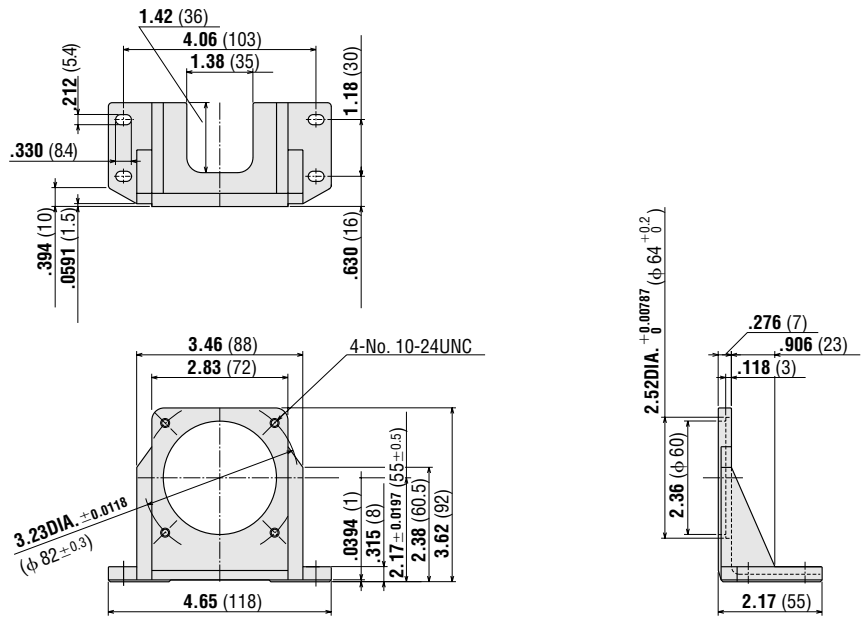

For 3.15 in. sq. (80mm sq.)

Model: **SOL4U10**
 Weight: 7.1oz(200g) Material: Aluminium

Compatible Motor and Gearhead

- **4GN□KA**
- 3.15 in sq.(80mm sq.) frame size motors

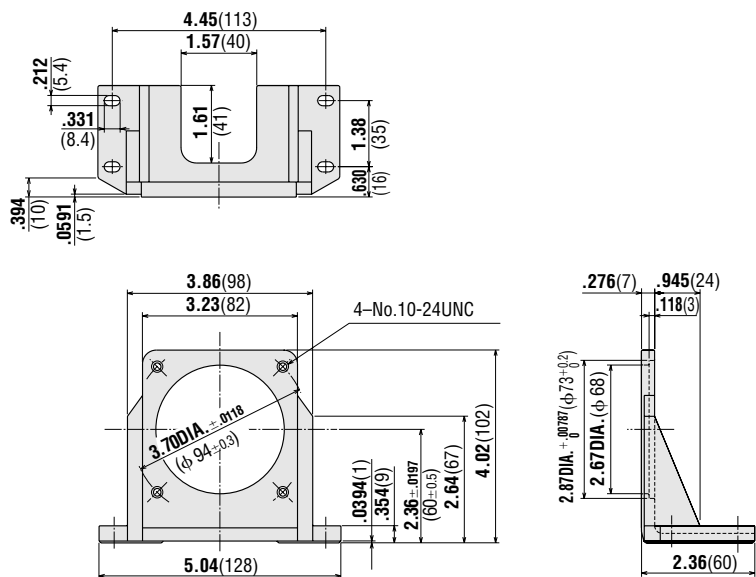

For 3.54 in. sq. (90mm sq.)

Model: **SOL5UA**
SOL5M8

Weight: 9.5oz(270g) Material: Aluminium

Compatible Motor and Gearhead

- **SOL5UA**
- **5GN□KA**
- **5GU□KA**
- 3.54 in sq.(90mm sq.) frame size motors
- **SOL5M8**
- **FBL II** Series

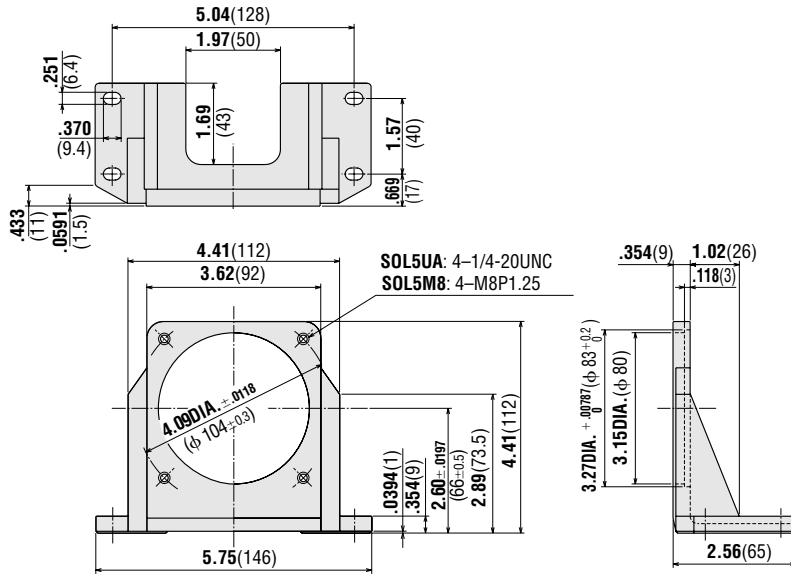

For 4.09 in. sq. (104mm sq.)

Model: **SOL6M8**

Weight: 13.4oz(380g) Material: Aluminium

Compatible Motor and Gearhead

- **BH**Series
- 4.09 in sq.(104mm sq.) frame size motors

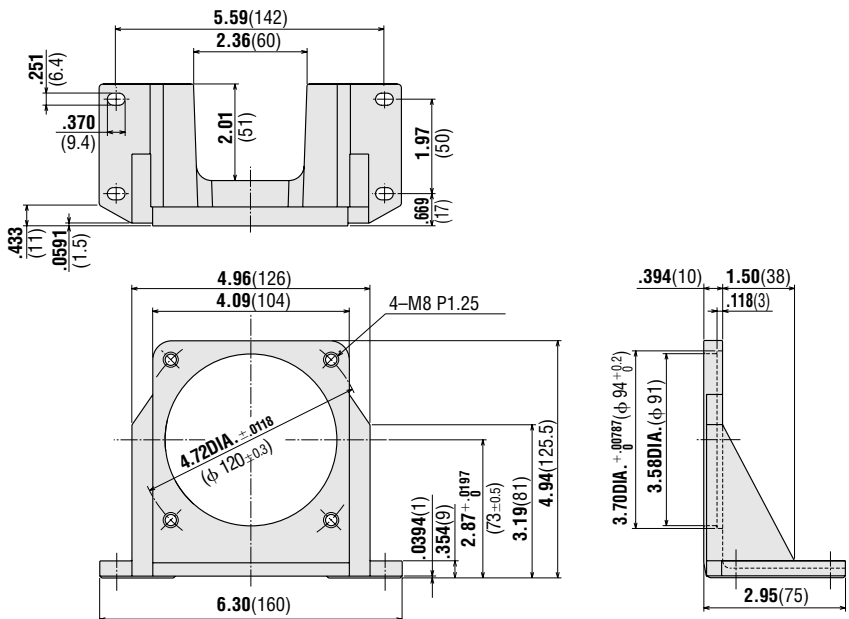

External Speed Indicator

To check the speed of speed control motors, connect the speed indicator.



Model: **SDM496** (Single-Phase 100~240VAC)

This digital speed indicator, displays a speed at the output shaft of the motor or gearhead.

Applicable Motor: **FBLII** series, **HBL** series, **US** series
Component type (**SS21-UL**)

Example of Connection with SS21UL Component Type

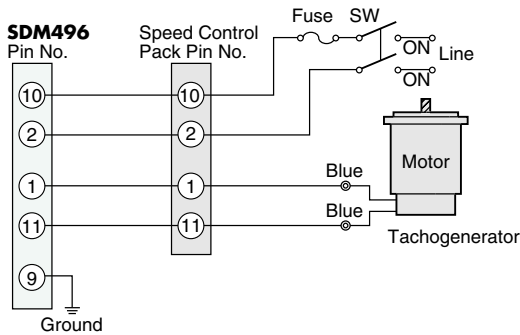

See page [A-163] for connection with unit type speed control motor.

Example of Connection with FBLII Series

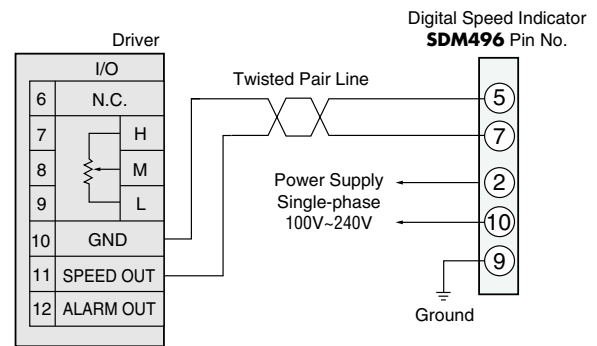

Dimensions Scale 1/4, Unit = inch (mm) Weight: 7.1 oz. (200 g)

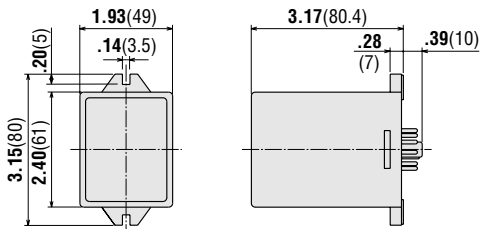

Dimensions with Adapter Attached Scale 1/4, Unit = inch (mm)

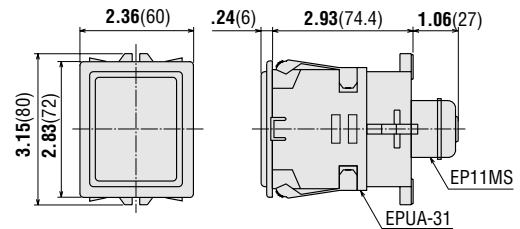

Optional Parts: A flush mounting adapter **EPUA-31** and round shape socket **EP11MS** are provided with the speed indicator.

External Speed Potentiometers

Model : **PAVR-20KY**
(20kΩ · 1/4W)

Dimensions Scale 1:2, Unit = inch (mm) Weight: 1.2 oz. (35 g)

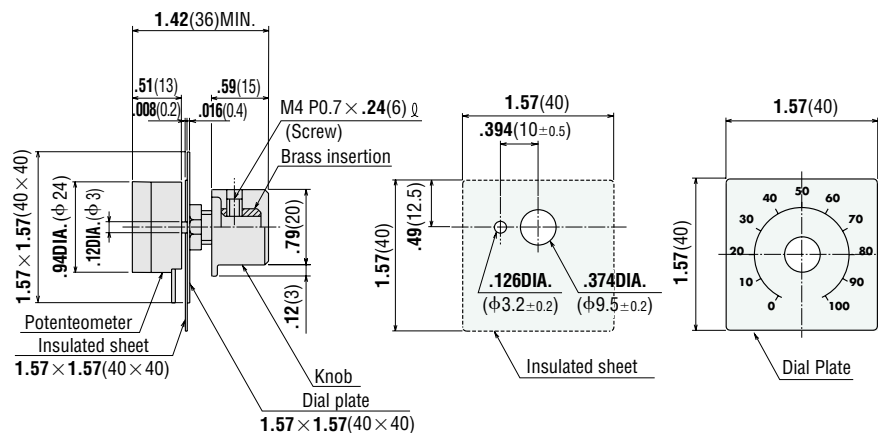

Model: **PAVR-20KZ**



● **Dimensions** Scale 1:2, Unit = inch (mm) Weight: 1.2 oz. (35 g)

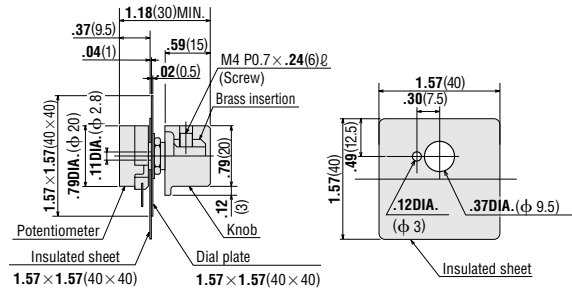

■ Extension Cables

● For **FBL II Series**

| Model | Length: ft. (m) |
|----------------|-----------------|
| CC01FBL | 3.3 (1) |
| CC02FBL | 6.6 (2) |
| CC03FBL | 9.8 (3) |
| CC05FBL | 16.4 (5) |
| CC07FBL | 23.0 (7) |
| CC10FBL | 32.8 (10) |

Maximum extension length is 34.4 ft (10.5m).

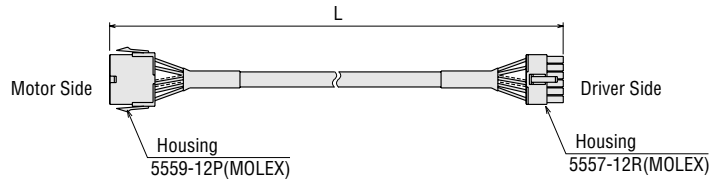

● For **HBL Series**

● **Applicable Products: HBL210, HBL425, HBL540** type

Model: **FC02HBL**

4.9ft (1.5m)

Maximum extension length is 6.6 ft. (2m)

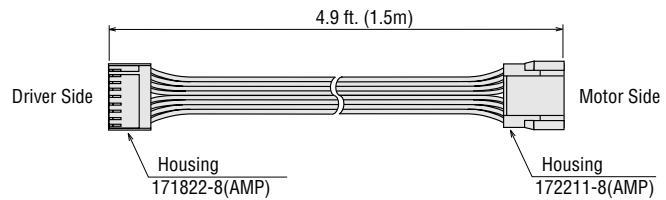

● **Applicable Products: HBL560, HBL5100** type

| Model | Length: ft. (m) |
|----------------|-----------------|
| CC01FBL | 3.3 (1) |
| CC02FBL | 6.6 (2) |
| CC03FBL | 9.8 (3) |
| CC05FBL | 16.4 (5) |

Maximum extension length is 18.8 ft. (5.5m)

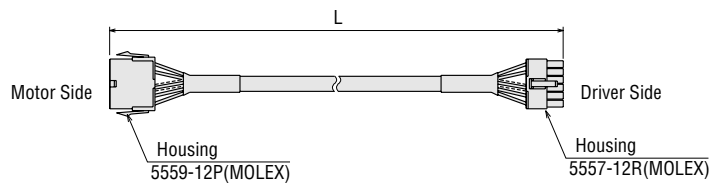

● For US Series

● Applicable Products:

US206, US315, US425, US540

| Model | Length: ft. (m) |
|------------------|-----------------|
| CC01SS052 | 3.3 (1) |
| CC02SS052 | 6.6 (2) |
| CC03SS052 | 9.8 (3) |
| CC04SS052 | 13.1 (4) |

● Applicable Products:

US560, US590

| Model | Length: ft. (m) |
|----------------|-----------------|
| CC01SS2 | 3.3 (1) |
| CC02SS2 | 6.6 (2) |
| CC03SS2 | 9.8 (3) |
| CC04SS2 | 13.1 (4) |

Maximum extension length is 15.0 ft. (4.75m)

Extension cable for connecting motor and control unit.

Two types are available, depending on the type of connector.

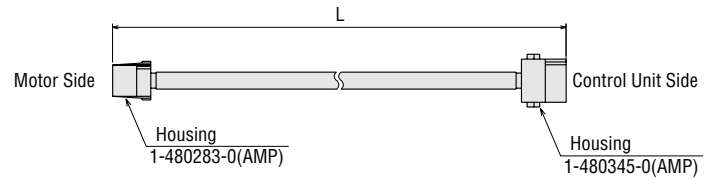
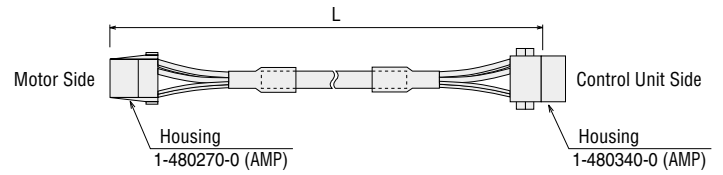

■ Din Rail Mounting Bracket

Use when installing the speed control pack and driver on DIN rails.

Model: **PADP01**

Applicable Products

● **FBL II** Series



● **Dimensions** Scale 1/4, Unit = inch (mm) Weight: 0.71oz (20g)

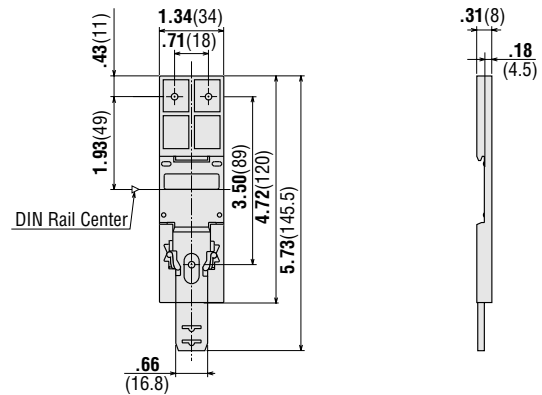

■ CR Circuit for Surge Suppression

This product is used to protect the contacts of the relay and/or switch used to control the motor direction.

Model: **EPCR1201-2**
AC250V (120Ω 0.1μF)



● **Dimensions** Scale 1:1, Unit = inch (mm) Weight: 0.18oz (5g)

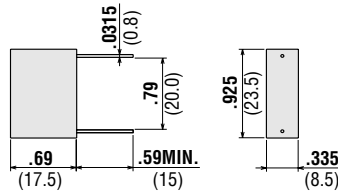

■ Power Relay Box

For use with the waterproof extension cable.

Model: **TB4-0608**



● **Dimensions** Unit = inch (mm) Weight: 5.3oz (150g)

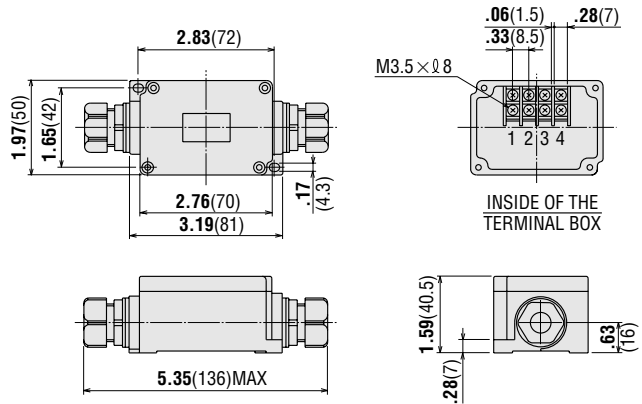

Applicable Motors

- Cable type:
FPW Series Induction type
BH Series
- Lead wire type:
Induction Motor
Reversible Motor
Torque Motor

Diameter of cable: .26DIA. (φ 6.5)~.33DIA. (φ 8.5)

- The relay box conforms to Protection Level IP65 when used with a waterproof extension cable on an FPW series induction motor.

The screws for the cover on the sealed connector and relay box should be adjusted to the torque shown below.

Sealed connector 8.7~13.0 lb-in (1.0~1.5 N·m)
Cover of power relay box 4.7~5.7 lb-in (0.54~0.66 N·m)

■ Extension Cable for Splashproof Motors

Use with the relay box above.

| Conductors | Model | Length : ft. (m) |
|------------|------------------|------------------|
| 3 | CC05AC33P | 16.4(5) |
| | CC10AC33P | 32.8 (10) |
| 4 | CC05AC43P | 16.4(5) |
| | CC10AC43P | 32.8 (10) |

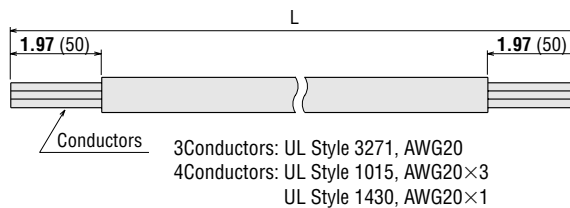

● Dog for Linear Head LH Series

● **Dimensions** Scale 1/4, Unit = inch (mm)

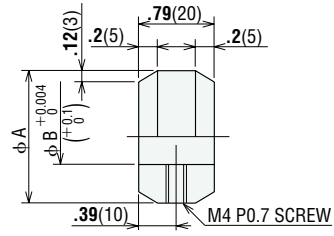

| Linear Head Model | Dog Model | A | | B | |
|--------------------|--------------|------|------|-----|--------|
| For 0L type | LXD0C | .17 | (18) | .31 | (8) |
| For 2L type | LXD2C | .94 | (24) | .54 | (13.8) |
| For 4L type | LXD4C | 1.18 | (30) | .78 | (19.8) |
| For 5L type | LXD5C | 1.38 | (35) | .98 | (24.8) |