

Technical Information



Imprint

As at:

8th edition, 2016

Copyright

by Dr. Fritz Faulhaber GmbH & Co. KG
Daimlerstr. 23 / 25 · 71101 Schönaich

All rights reserved, including translation rights. No part of this description may be duplicated, reproduced, stored in an information system or processed or transferred in any other form without prior express written permission of Dr. Fritz Faulhaber GmbH & Co. KG.

This document has been prepared with care. Dr. Fritz Faulhaber GmbH & Co. KG cannot accept any liability for any errors in this document or for the consequences of such errors. Equally, no liability can be accepted for direct or consequential damages resulting from improper use of the products.

Subject to modifications.

The respective current version of this document is available on FAULHABER's website: www.faulhaber.com

Contents

DC-Motors	DC-Micromotors Flat DC-Micromotors & DC-Gearmotors	4 – 15
Brushless DC-Motors	Brushless DC-Servomotors Brushless Flat DC-Micromotors & DC-Gearmotors Brushless DC-Motors with integrated Speed Controller	16 – 27
Motion Control Systems	Brushless DC-Servomotors with integrated Motion Controller	28 – 32
Stepper Motors	Stepper Motors	33 – 38
Linear DC-Servomotors	Linear DC-Servomotors	39 – 44
Precision Gearheads	Precision Gearheads	45 – 50
Linear Components	Ball Screws Lead Screws and Options	51 – 57
Encoders	Encoders – 2 Channel Encoders – 3 Channel Encoder – Absolute	58 – 64
Drive Electronics	Speed Controller Motion Controller	65 – 71

DC-Motors



DC-Micromotors

Technical Information

General information

The FAULHABER Winding:

Originally invented by Dr. Fritz Faulhaber Sr. and patented in 1958, the System FAULHABER coreless (or ironless) progressive, self-supporting, skew-wound rotor winding is at the heart of every System FAULHABER DC Motor. This revolutionary technology changed the industry and created new possibilities for customer application of DC Motors where the highest power, best dynamic performance, in the smallest possible size and weight are required. The main benefits of this technology include:

- No cogging torque resulting in smooth positioning and speed control and higher overall efficiency than other DC motor types
- Extremely high torque and power in relation to motor size and weight
- Absolute linear relationship between load to speed, current to torque, and voltage to speed
- Very low rotor inertia which results in superior dynamic characteristics for starting and stopping
- Extremely low torque ripple and EMI

DC Motor Types:

FAULHABER DC Motors are built with two different types of commutation systems: precious metal commutation and graphite commutation.

The term precious metal commutation refers to the materials used in the brushes and commutator which consist of high performance precious metal alloys. This type of commutation system is used mainly because of its very small size, very low contact resistance and the very precise commutation signal. This commutation system is particularly well suited for low current applications such as battery operated devices.

In general, precious metal commutated motors exhibit the best overall performance at continuous duty with a load at or around the point of maximum nominal efficiency.

The term graphite commutation refers to the brush material used in combination with a copper alloy commutator. This type of commutation system is very robust and is better suited to dynamic high power applications with rapid start / stops or periodic overload conditions.

Magnets:

FAULHABER DC Motors are designed with a variety of different types of magnets to suit the particular performance of the given motor type. These materials include AlNiCo magnets and high performance rare earth types such as SmCo and NdFeB.

Operational Lifetime:

The lifetime of a FAULHABER DC Motor depends mainly on the operational duty point and the ambient conditions during operation. The total hours of operation can therefore vary greatly from some hundreds of hours under extreme conditions to over 25 000 hours under optimal conditions. Under typical load conditions a FAULHABER DC motor will have an operational lifetime anywhere between 1 000 to 5 000 hours.

In general the operational lifetime of a FAULHABER DC Motor is limited by the effects of electrical and mechanical wear on the commutator and brushes. The electrical wear (sparking) depends heavily on the electrical load and the motor speed. As the electrical load and speed increase, the typical motor operational lifetime will normally decrease. The effects of electrical wear are more significant for motors with precious metal commutation and vary depending on the nominal voltage of the winding. Where necessary FAULHABER DC Motors are therefore fitted with integrated spark suppression to minimize the negative effects of sparking on the operational lifetime.

The mechanical wear of the commutation system is dependent on the motor speed and will increase with higher speeds. In general, for applications with higher than specified speeds and loads, a longer operational lifetime can be achieved by graphite commutated motors. It is also important not to exceed the load characteristics for the motor bearings given in the data sheet for continuous duty operation. Doing so will also limit the achievable motor lifetime.

Other effects limiting motor lifetime include ambient conditions like excessive humidity and temperature, excessive vibration and shock, and an incorrect or suboptimal mounting configuration of the motor in the application.

It is also important to note that the method of driving and controlling the motor will have a large effect on the operational lifetime of the motor. For example, for control using a PWM signal, FAULHABER recommends a minimum frequency of 20 kHz.

Modifications:

FAULHABER specializes in the configuration of its standard products to fit the customer application. Available modifications for FAULHABER DC Motors include:

- Many other nominal voltage types
- Motor leads (PTFE and PVC) and connectors
- Configurable shaft lengths and second shaft ends
- Modified shaft dimensions and pinion configurations such as flats, gears, pulley and eccenters
- Modifications for extreme high and low temperature operation
- Modifications for operation in a vacuum (ex. 10^{-7} Torr)
- Modifications for high speed and / or high load applications
- Modifications for motors with tighter than standard electrical or mechanical tolerances

Product Combinations

FAULHABER offers the industry's largest selection of complementary products tailor made for all of its DC Motors including:

- Precision Gearheads (planetary, spur, and low backlash spur)
- High resolution Encoders (Incremental and Absolute)
- High Performance Drive Electronics (Speed Controllers, Motion Controllers)

DC-Micromotors

Precious Metal Commutation

Series 0615 ... S

Values at 22°C and nominal voltage		0615 N
1	Nominal voltage	U_N
2	Terminal resistance	R
3	Output power	$P_{2nom.}$
4	Efficiency, max.	$\eta_{max.}$
5	No-load speed	
6	No-load current	

Notes on technical datasheet

The following values are measured or calculated at nominal voltage with an ambient temperature of 22 °C.

Nominal voltage U_N [V]

The nominal voltage at which all other characteristics indicated are measured and rated.

Terminal resistance R [Ω] $\pm 12\%$

The resistance measured across the motor terminals.

The value will vary according to the winding temperature. (temperature coefficient: $\alpha_{22} = 0,004 \text{ K}^{-1}$).

This type of measurement is not possible for the graphite commutated motors due to the transition resistance of the brushes.

Output power $P_{2nom.}$ [W]

The maximum mechanical power achieved at the nominal voltage.

$$P_{2nom.} = \frac{R}{4} \cdot \left(\frac{U_N}{R} - I_o \right)^2$$

Efficiency $\eta_{max.}$ [%]

The maximum ratio between the absorbed electrical power and the obtained mechanical power of the motor.

$$\eta_{max.} = \left(1 - \frac{I_o \cdot R}{U_N} \right)^2$$

No-load speed n_o [min^{-1}] $\pm 12\%$

Describes the motor speed under no-load conditions at steady state and 22 °C ambient temperature. If not otherwise defined the tolerance for the no-load speed is assumed to be $\pm 12\%$.

$$n_o = \frac{U_N - (I_o \cdot R)}{2\pi \cdot k_M}$$

No-load current (typical) I_o [A]

Describes the typical current consumption of the motor without load at an ambient temperature of 22 °C after reaching a steady state condition.

DC-Micromotors

Technical Information

The no-load current is speed and temperature dependent. Changes in ambient temperature or cooling conditions will influence the value. In addition, modifications to the shaft, bearing, lubrication, and commutation system or combinations with other components such as gearheads or encoders will all result in a change to the no-load current of the motor.

Stall torque M_H [mNm]

The torque developed by the motor at zero speed (locked rotor) and nominal voltage. This value may vary due to the magnet type and temperature and the temperature of the winding.

$$M_H = k_M \cdot \frac{U_N}{R} - M_R$$

Friction torque M_R [mNm]

Torque losses caused by the friction of brushes, commutator and bearings. This value varies due to temperature.

$$M_R = k_M \cdot I_o$$

Speed constant k_n [min^{-1}/V]

The speed variation per Volt applied to the motor terminals at constant load.

$$k_n = \frac{n_o}{U_N - I_o \cdot R} = \frac{1}{k_E}$$

Back-EMF constant k_E [$\text{mV}/\text{min}^{-1}$]

The constant corresponding to the relationship between the induced voltage in the rotor and the speed of rotation.

$$k_E = 2\pi \cdot k_M$$

Torque constant k_M [mNm/A]

The constant corresponding to the relationship between the torque developed by the motor and the current drawn.

Current constant k_I [A/mNm]

Describes the relation of the current in the motor winding and the torque developed at the output shaft.

$$k_I = \frac{1}{k_M}$$

Slope of n-M curve $\Delta n/\Delta M$ [$\text{min}^{-1}/\text{mNm}$]

The ratio of the speed variation to the torque variation. The smaller the value, the more powerful the motor.

$$\frac{\Delta n}{\Delta M} = \frac{R}{k_M^2} \cdot \frac{1}{2\pi}$$

Rotor inductance L [μH]

The inductance measured on the motor terminals at 1 kHz.

Mechanical time constant τ_m [ms]

The time required for the motor to reach a speed of 63% of its final no-load speed, from standstill.

$$\tau_m = \frac{R \cdot J}{k_M^2}$$

Rotor inertia J [gcm^2]

The dynamic moment of inertia of the rotor.

Angular acceleration α_{max} [rad/s^2]

The acceleration obtained from standstill under no-load-conditions and at nominal voltage.

$$\alpha_{\text{max}} = \frac{M_H}{J}$$

Thermal resistance R_{th1} ; R_{th2} [K/W]

R_{th1} corresponds to the thermal resistance between the winding and housing. R_{th2} corresponds to the thermal resistance between the housing and the ambient air. R_{th2} can be reduced by enabling exchange of heat between the motor and the ambient air (for example, a thermally coupled mounting configuration, using a heat sink, and / or forced air cooling).

Thermal time constant τ_{w1} ; τ_{w2} [s]

The thermal time constant specifies the time needed for the winding (τ_{w1}) and housing (τ_{w2}) to reach a temperature equal to 63% of final steady state value.

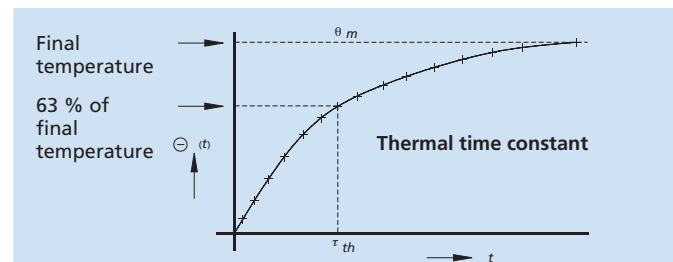

Operating temperature range [$^{\circ}\text{C}$]

Indicates the minimum and maximum standard motor operating temperature, as well as the maximum allowable temperature of the standard motor winding.

Shaft bearings

The bearings used for the DC-Micromotors.

Shaft load max. [N]

The output shaft load at a specified shaft diameter for the primary output shaft. For motors with ball bearings the load and lifetime are in accordance with the values given by the bearing manufacturers. This value does not apply to second, or rear shaft ends.

Shaft play [mm]

The play between the shaft and bearings, including the additional bearing play in the case of ball bearings.

Housing material

The housing material and the surface protection.

Mass [g]

The typical mass of the motor in its standard configuration.

Direction of rotation

The direction of rotation as viewed from the front face. Positive voltage applied to the (+) terminal gives clockwise rotation of the motor shaft. All motors are designed for clockwise (CW) and counter-clockwise (CCW) operation; the direction of rotation is reversible.

Speed up to n_{max} . [min^{-1}]

The maximum recommended motor speed for continuous operation. This value is based on the recommended operating range for the standard motor bearings, winding, and commutation system. All values in excess of this value will negatively affect the maximum achievable operational lifetime of the motor.

Number of pole pairs

Indicates the number of pole pairs of the standard motor.

Magnet material

Describes the basic type of the magnet used in the standard motor.

Unspecified mechanical tolerances:

Tolerances in accordance with ISO 2768.

≤ 6 = ± 0,1 mm

≤ 30 = ± 0,2 mm

≤ 120 = ± 0,3 mm

The tolerances of values not specified are given on request.

All mechanical dimensions related to the motor shaft are measured with an axial preload of the shaft toward the motor.

Rated Values for Continuous Duty Operation

The following values are measured or calculated at nominal voltage with an ambient temperature of 22 °C.

Rated Torque M_N [mNm]

For DC motors with precious metal commutation:

The maximum continuous duty torque at nominal voltage resulting in steady state current and speed not exceeding the capacity of the brush and commutation system. The motor is rated without a reduction to the R_{th2} value (without external cooling). This value can be safely exceeded if the motor is operated intermittently, for example, in S2 operation and/or if more cooling is applied. For the purposes of the rating, certain motors are limited by the resulting rated speed (< 2 500 min^{-1}) at nominal voltage.

Please note, when choosing a precious metal commutated motor that they exhibit the best overall continuous duty performance at or around the point of highest efficiency. For continuous duty operating conditions that require the motor to operate close to its thermal limits, a DC Motor with graphite commutation is recommended.

For DC Motors with graphite commutation:

The maximum continuous duty torque (S1 operation) at nominal voltage resulting in a steady state temperature not exceeding the maximum winding temperature and / or operating temperature range of the motor. The motor is rated with a reduction of the R_{th2} value of 25% which approximates the amount of cooling available from a typical mounting configuration of the motor. This value can be safely exceeded if the motor is operated intermittently, for example, in S2 operation and/or if more cooling is applied.

Rated Current (thermal limit) I_N [A]

The typical maximum continuous current at steady state resulting from the rated continuous duty torque. This value includes the effects of a loss of K_m (torque constant) as it relates to the temperature coefficient of the winding as well as the thermal characteristics of the given magnet material. This value can be safely exceeded if the motor is operated intermittently, during start / stop, in the ramp up phases of the operating cycle and/or if more cooling is applied. For certain series and lower voltage types this current is limited by the capacity of the brush and commutation system.

Rated Speed n_N [min^{-1}]

The typical speed at steady state resulting from the application of the given rated torque. This value includes the effects of motor heating on the slope of the n/M curve. Higher speeds can be achieved by increasing the input voltage to the motor, however the rated current (thermal limit) remains the same.

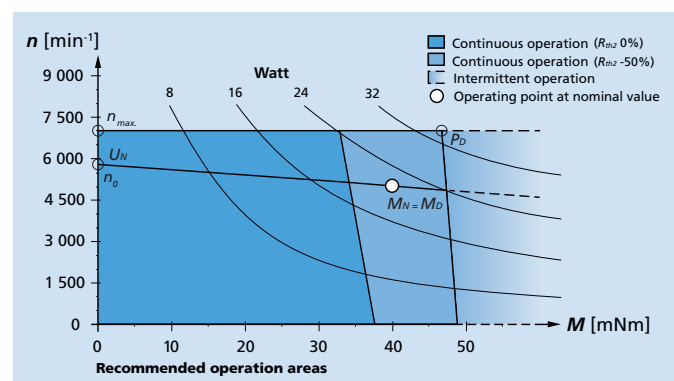

Example: Performance diagram for rated values with continuous operation (graphite commutation)

DC-Micromotors

Technical Information

Explanations on the Performance Diagram

The performance diagram shows the range of possible operating points of a drive at an ambient temperature of 22 °C and includes both the operation in the thermally insulated and in the cooled state. The possible speed ranges are shown in dependence on the shaft torque.

The sector shown dashed describes possible operating points in which the drive can be engaged in intermittent operation or with increased cooling.

Continuous torque M_D [mNm]

Describes the max. recommended continuous torque in the steady-state condition at nominal voltage and with thermal reduction of the $R_{th,2}$ value by 25 % for graphite commutation and by 0 % for precious metal commutation. With brush motors, the continuous torque corresponds to the respective rated torque M_N . The value is independent of the continuous output and can be exceeded if the motor is intermittently operated and/or more cooling is put to use.

Continuous output P_D [W]

Describes the max. possible output in continuous operation in the steady-state condition with thermal reduction of the $R_{th,2}$ value by 50 %. The value is independent of the continuous torque and can be exceeded if the motor is intermittently operated and/or more cooling is put to use.

Nominal voltage characteristic curve U_N [V]

The nominal voltage curve describes the operating points at U_N in the uncooled and cooled state. In steady-state, the starting point corresponds to the no-load speed n_0 of the drive. Operating points above this curve can be attained by an increase, operating points below by a reduction of the nominal voltage.

How to select a DC-Micromotor

This section provides a very basic step-by-step procedure of how to select a DC-Micromotor for an application that requires continuous duty operation under constant load and ambient conditions. The example describes the calculations necessary to create a basic motor characteristic curve to describe the behaviour of the motor in the application. To simplify the calculation, in this example continuous operation and optimum life performance are assumed and the influence of temperature and tolerances has been omitted.

Application data:

The basic data required for any given application are:

Required torque	M
Required speed	n
Duty cycle	δ
Available supply voltage, max.	U
Available current, max.	I
Available space, max.	diameter/length
Shaft load	radial/axial
Ambient temperature	

This example is based on the following application data:

Output torque	M	= 3	mNm
Speed	n	= 5 500	min ⁻¹
Duty cycle	δ	= 100	%
Supply voltage	U	= 20	V
Current source, max.	I	= 0,5	A
Space max	diameter	= 25	mm
	length	= 50	mm
Shaft load	radial	= 1,0	N
	axial	= 0,2	N
Ambient temperature		= 22 °C	constant

Preselection

The first step is to calculate the power the motor is expected to deliver:

$$P_2 = M \cdot 2 \cdot \pi n$$

$$P_2 = 3 \text{ mNm} \cdot 5\,500 \text{ min}^{-1} \cdot 2\pi = 1,73 \text{ W}$$

A motor is then selected from the catalogue which will give at least 1,5 to 2 times the output power $P_{2 \text{ nom}}$ than the one obtained by calculation, and where the nominal voltage is equal to or higher than the one required in the application data.

The physical dimensions (diameter and length) of the motor selected from the data sheets should not exceed the available space in the application.

$$P_{2 \text{ nom}} \geq P_2$$

$$U_N \geq U$$

The motor selected from the catalogue for this particular application, is **series 2224 U 024 SR** with the following characteristics:

Nominal voltage	U_N	= 24	V
Output power, max.	$P_{2\,nom.}$	= 3,88	W
Frame size:	\varnothing	= 22	mm
	L	= 24	mm
Shaft load, max.:	radial	= 1,5	N
	axial	= 0,2	N
No-load current	I_o	= 0,007	A
No-load speed	n_o	= 7 800	min ⁻¹
Stall torque	M_H	= 19	mNm

Caution:

Should the available supply voltage be lower than the nominal voltage U_N of the selected DC-Micromotor, it will be necessary to calculate $P_{2\,nom.}$ with the following equation:

$$P_{2\,nom.} = \frac{R}{4} \cdot \left(\frac{U}{R} - I_o \right)^2$$

$$P_{2\,nom.}(20\text{ V}) = \frac{36,3\ \Omega}{4} \cdot \left(\frac{20\text{ V}}{36,3\ \Omega} - 0,007\text{ A} \right)^2 = 2,69\ \text{W}$$

Optimizing the preselection

To optimize the motor's operation and life performance, the required speed n has to be higher than half the no-load speed n_o at nominal voltage, and the load torque M has to be less than half the stall torque M_H .

$$n \geq \frac{n_o}{2} \quad M \leq \frac{M_H}{2}$$

From the data sheet for the DC-Micromotor, **2224 U 024 SR** the parameters meet the above requirements.

$$n = 5\,500\ \text{min}^{-1} \quad \text{is higher than} \quad \frac{7\,800\ \text{min}^{-1}}{2} = 3\,900\ \text{min}^{-1} = \frac{n_o}{2}$$

$$M = 3\ \text{mNm} \quad \text{is lower than} \quad \frac{19\ \text{mNm}}{2} = 9,5\ \text{mNm} = \frac{M_H}{2}$$

This DC-Micromotor will be a good first choice to test in this application. Should the required speed n be less than half the no-load speed n_o , and the load torque M be less than half the stall torque M_H , the motor with the next higher nominal voltage U_N should be selected.

Should the required torque M be compliant but the required speed n be less than half the no-load speed n_o , try a lower supply voltage or another smaller frame size motor.

Should the required speed be well below half the no-load speed and or the load torque M be more than half the stall torque M_H , a gearhead or a larger frame size motor has to be selected.

Performance characteristics at nominal voltage (24 V)

A graphic presentation of the motor's characteristics can be obtained by calculating the stall current I_H and the torque $M_{opt.}$ at its point of max. efficiency. All other parameters are taken directly from the data sheet of the selected motor.

Stall current

$$I_H = \frac{U_N}{R}$$

$$I_H = \frac{24\text{ V}}{36,3\ \Omega} = 0,661\ \text{A}$$

Torque at max. efficiency

$$M_{opt.} = \sqrt{M_H \cdot M_R}$$

$$M_{opt.} = \sqrt{19\ \text{mNm} \cdot 0,2\ \text{mNm}} = 1,95\ \text{mNm}$$

It is now possible to make a graphic presentation and draw the motor diagram (see diagram 1).

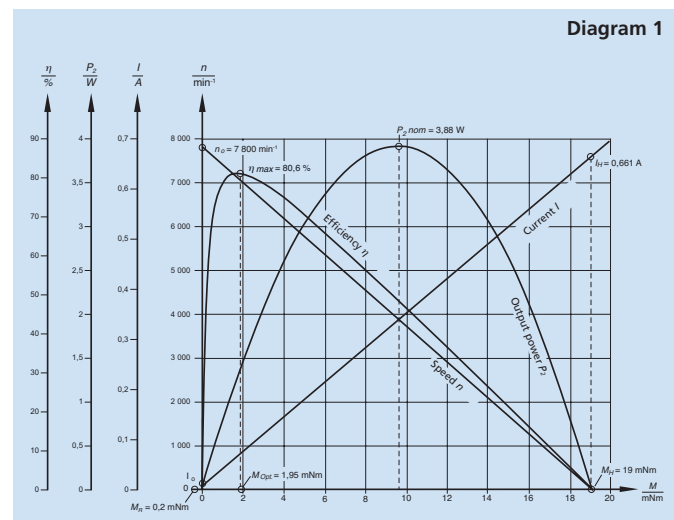

DC-Micromotors

Technical Information

Calculation of the main parameters

In this application the available supply voltage is lower than the nominal voltage of the selected motor.

The calculation under load therefore is made at 20 V.

No-load speed n_o at 20 V

$$n_o = \frac{U - (I_o \cdot R)}{2\pi \cdot k_M}$$

inserting the values

Supply voltage	U	=	20	V
Terminal resistance	R	=	36,3	Ω
No-load current	I_o	=	0,007	A
Torque constant	k_M	=	29,1	mNm / A

$$n_o = \frac{20 \text{ V} - (0,007 \text{ A} \cdot 36,3 \Omega)}{2\pi \cdot 29,1 \text{ mNm / A}} = 6\,481 \text{ min}^{-1}$$

Stall current I_H

$$I_H = \frac{U}{R}$$

$$I_H = \frac{20 \text{ V}}{36,3 \Omega} = 0,551 \text{ A}$$

Stall torque M_H

$$M_H = k_M \left(\frac{U}{R} - I_o \right)$$

$$M_H = 29,1 \text{ mNm / A} \cdot \left(\frac{20 \text{ V}}{36,3 \Omega} - 0,007 \text{ A} \right) = 15,83 \text{ mNm}$$

Output power, max. $P_{2 \text{ nom}}$

$$P_{2 \text{ nom}} = \frac{R}{4} \cdot \left(\frac{U}{R} - I_o \right)^2$$

$$P_{2 \text{ nom}}(20 \text{ V}) = \frac{36,3 \Omega}{4} \cdot \left(\frac{20 \text{ V}}{36,3 \Omega} - 0,007 \text{ A} \right)^2 = 2,69 \text{ W}$$

Efficiency, max. η_{max}

$$\eta_{\text{max}} = \left(1 - \sqrt{I_o \cdot \frac{R}{U}} \right)^2$$

$$\eta_{\text{max}} = \left(1 - \sqrt{0,007 \text{ A} \cdot \frac{36,3 \Omega}{20 \text{ V}}} \right)^2 = 78,9 \%$$

At the point of max. efficiency, the torque delivered is:

$$M_{\text{opt.}} = \sqrt{M_H \cdot M_R}$$

inserting the values

Friction torque and	M_R	=	0,2	mNm
Stall torque with 20 V	M_H	=	15,83	mNm

$$M_{\text{opt.}} = \sqrt{15,83 \text{ mNm} \cdot 0,2 \text{ mNm}} = 1,78 \text{ mNm}$$

Calculation of the operating point at 20 V

When the torque ($M=3 \text{ mNm}$) at the working point is taken into consideration I , n , P_2 and η can be calculated:

Current at the operating point

$$I_{\text{Last}} = \frac{M + M_R}{k_M}$$

$$I_{\text{Last}} = \frac{3 \text{ mNm} + 0,2 \text{ mNm}}{29,1 \text{ mNm / A}} = 0,11 \text{ A}$$

Speed at the operating point

$$n = \frac{U - R \cdot I_{\text{Last}}}{2\pi \cdot k_M}$$

$$n = \frac{20 \text{ V} - 36,3 \Omega \cdot 0,11 \text{ A}}{2\pi \cdot 29,1 \text{ mNm / A}} = 5\,253 \text{ min}^{-1}$$

Output power at the operating point

$$P_2 = M \cdot 2\pi \cdot n$$

$$P_2 = 3 \text{ mNm} \cdot 2\pi \cdot 5\,253 \text{ min}^{-1} = 1,65 \text{ W}$$

Efficiency at the operating point

$$\eta = \frac{P_2}{U \cdot I}$$

$$\eta = \frac{1,65 \text{ W}}{20 \text{ V} \cdot 0,11 \text{ A}} = 75,0 \%$$

In this example the calculated speed at the working point is different to the required speed, therefore the supply voltage has to be changed and the calculation repeated.

Supply voltage at the operating point

The exact supply voltage at the operating point can now be obtained with the following equation:

$$U = R \cdot I_{\text{Load}} + 2\pi \cdot n \cdot k_M$$

$$U = 36,3 \Omega \cdot 0,11 \text{ A} + 2\pi \cdot 5\,500 \text{ min}^{-1} \cdot 29,1 \text{ mNm / A} = 20,75 \text{ V}$$

In this calculated example, the parameters at the operating point are summarized as follows:

Supply voltage	U	=	20,75	V
Speed	n	=	5 500	min ⁻¹
Output torque	M_N	=	3	mNm
Current	I	=	0,11	A
Output power	P_2	=	1,73	W
Efficiency	η	=	75,7	%

Estimating the temperature of the motor winding in operation:

To ensure that the motor operates within a permissible temperature range, it is necessary to calculate the temperature of the winding and housing under load. First calculate the approximate motor losses using the following formula:

$$P_{Loss} = I_{Load}^2 \cdot R$$

inserting the values

Current	$I_{Load} = 0,11 \text{ A}$
Resistance	$R = 36,3 \Omega$

$$P_{Loss} = (0,11 \text{ A})^2 \cdot 36,3 \Omega = 0,44 \text{ W}$$

Then multiply the value for the power losses by the combined thermal resistances of the motor to estimate the change in the temperature of the motor due to the load.

$$\Delta T = P_{Loss} \cdot (R_{th1} + R_{th2})$$

inserting the values

Thermal resistance 1	$R_{th1} = 5 \text{ K/W}$
Thermal resistance 2	$R_{th2} = 20 \text{ K/W}$

$$\Delta T = 0,44 \text{ W} \cdot (5 \text{ K/W} + 20 \text{ K/W}) = 11 \text{ K}$$

Add the resulting change in temperature ΔT to the ambient temperature to estimate the motor winding temperature under load.

$$T_{Winding} = \Delta T + T_{Amb}$$

$$T_{Winding} = 11 \text{ K} + 22 \text{ °C} = 33 \text{ °C}$$

This calculation confirms that the temperature is well within the specified standard operating temperature range as well as the maximum winding temperature.

The calculation given above is for the purposes of a quick estimation only. The non-linear effects of temperature on the resistance of the winding and the resulting torque constant (k_M) of the motor due to the temperature coefficient of the magnet material used have not been taken into account and can have a large effect on motor performance at higher temperatures. A more detailed calculation should be performed before operating the motor close to its thermal limits.

Motor characteristic curves

For a specific torque, the various parameters can be read on diagram 2.

To simplify the calculation, the influence of temperature and tolerances has deliberately been omitted.

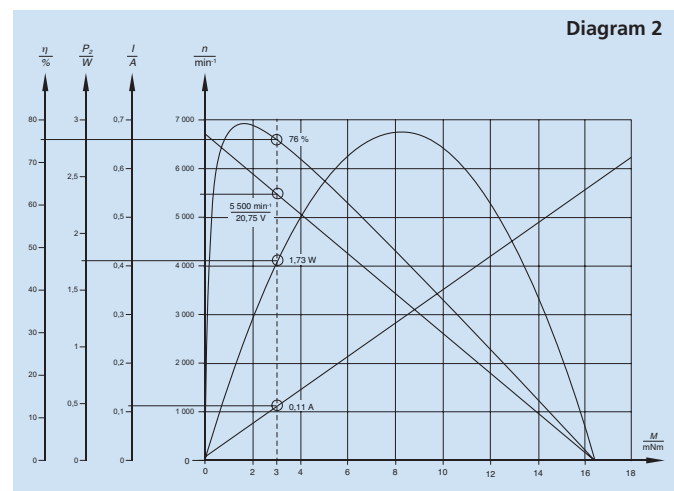

DC-Micromotors

Precious Metal Commutation

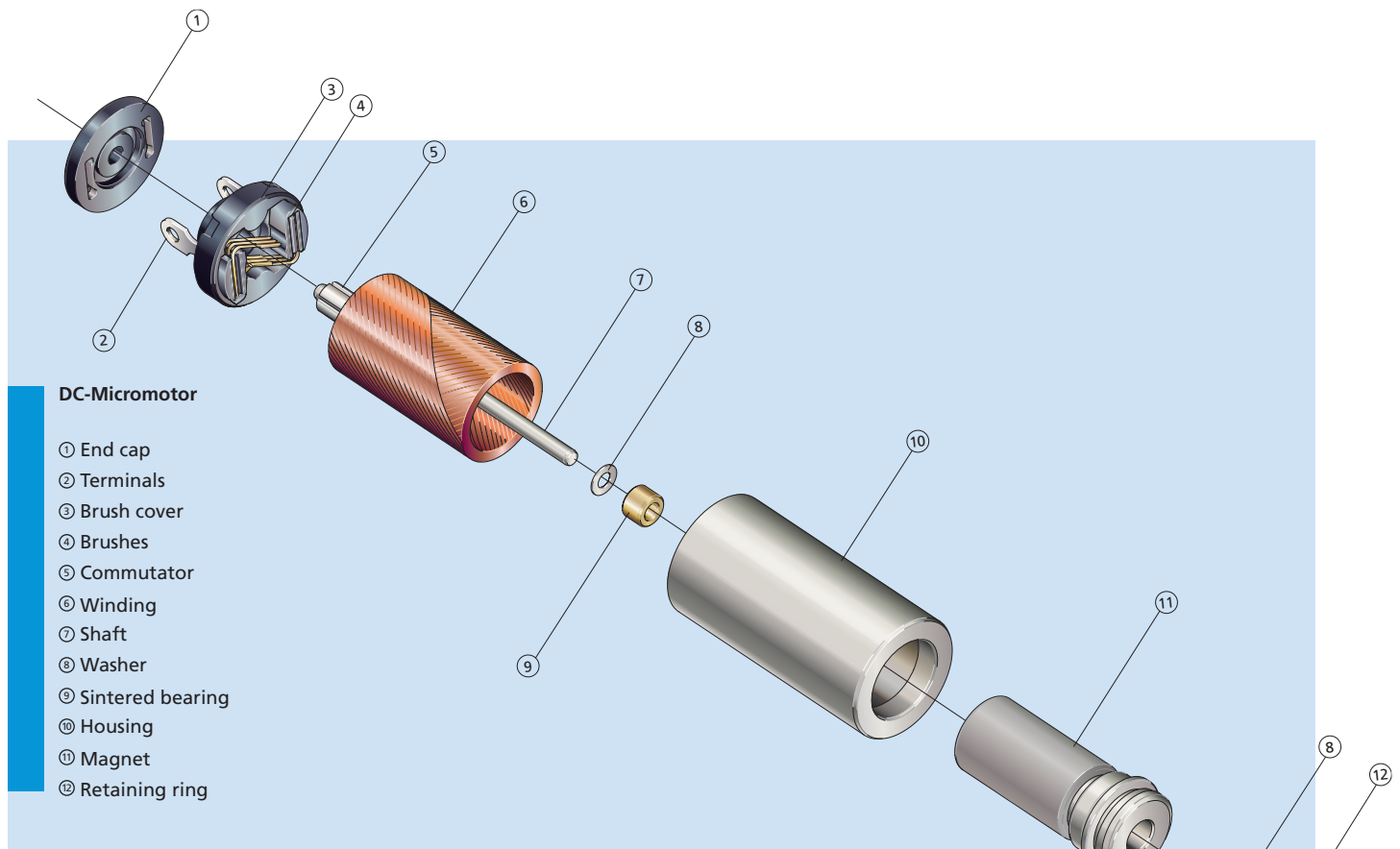

DC-Micromotor

- ① End cap
- ② Terminals
- ③ Brush cover
- ④ Brushes
- ⑤ Commutator
- ⑥ Winding
- ⑦ Shaft
- ⑧ Washer
- ⑨ Sintered bearing
- ⑩ Housing
- ⑪ Magnet
- ⑫ Retaining ring

Features

The main difference between FAULHABER DC-Micromotors and conventional DC motors is in the rotor. The rotor does not have an iron core but consists of a self-supporting skew-wound copper winding. This featherweight rotor has an extremely low moment of inertia, and it rotates without cogging. The result is the outstanding dynamics of FAULHABER motors. For low power motors, commutation systems using precious metals are the optimum solution because of their low contact resistance.

FAULHABER precious metal commutated motors range in size from just 6 mm to 22 mm in diameter.

FAULHABER completes the drive system by providing a variety of additional hightech standard components including high resolution encoders, precision gearheads, and drive electronics. FAULHABER specializes in the modification of their drive systems to fit the customer's particular application requirements. Common modifications include vacuum compatibility, extreme temperature compatibility, modified shaft geometry, additional voltage types, custom motor leads and connectors, and much more.

Benefits

- Ideal for battery operated devices
- No cogging
- Extremely low current consumption – low starting voltage
- Highly dynamic performance due to a low inertia, low inductance winding
- Light and compact
- Precise speed control
- Simple to control due to the linear performance characteristics

Product Code



08	Motor diameter
16	Motor length [mm]
N	Shaft type
012	Nominal voltage [V]
S	Type of commutation (precious metal)
R	Version (rare earth magnet)

0816 N 012 S R

DC-Micromotors

Graphite Commutation

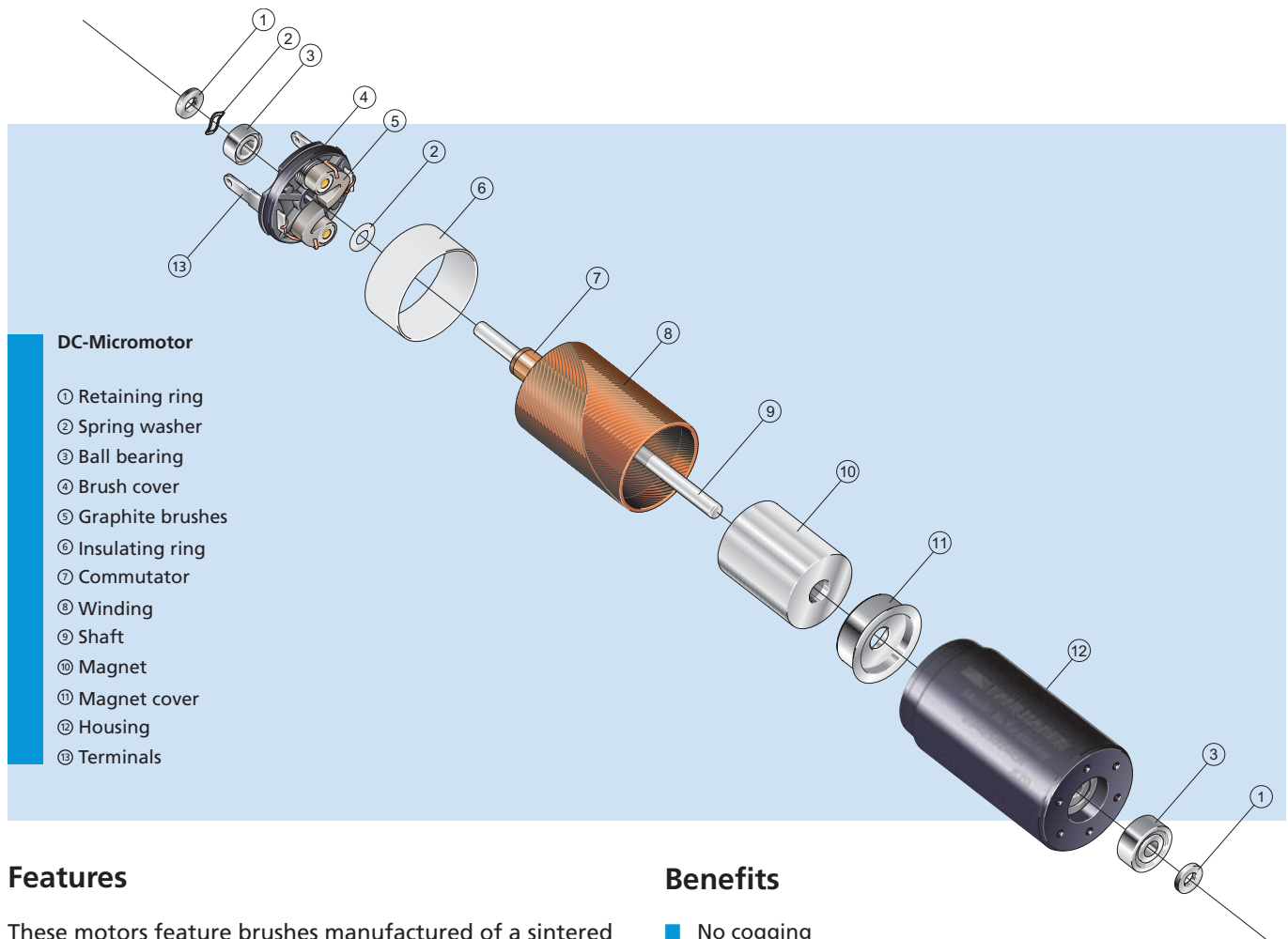

DC-Micromotor

- ① Retaining ring
- ② Spring washer
- ③ Ball bearing
- ④ Brush cover
- ⑤ Graphite brushes
- ⑥ Insulating ring
- ⑦ Commutator
- ⑧ Winding
- ⑨ Shaft
- ⑩ Magnet
- ⑪ Magnet cover
- ⑫ Housing
- ⑬ Terminals

Features

These motors feature brushes manufactured of a sintered metal graphite material and a copper commutator. This ensures that the commutation system can withstand more power and still deliver exceptionally long operational lifetimes.

A multitude of adaptations for customer specific requirements and special executions are available.

FAULHABER motors with graphite brushes range in size from just 13 mm to 38 mm in diameter.

FAULHABER completes the drive system by providing a variety of additional high-tech standard components including high resolution encoders, precision gearheads, drive electronics, brakes and other servo components. FAULHABER specializes in the modification of their drive systems to fit the customer's particular application requirements. Common modifications include vacuum compatibility, extreme temperature compatibility, modified shaft geometry, additional voltage types, custom motor leads and connectors, and much more.

Benefits

- No cogging
- High power density
- Highly dynamic performance due to a low inertia, low inductance winding
- Light and compact
- Precise speed control
- Simple to control due to the linear performance characteristics

Product Code



23	Motor diameter [mm]
42	Motor length [mm]
S	Shaft type
024	Nominal voltage [V]
C	Type of commutation (Graphite)
R	Version (rare earth magnet)

2342 S 024 CR

Flat DC-Micromotors

Precious Metal Commutation

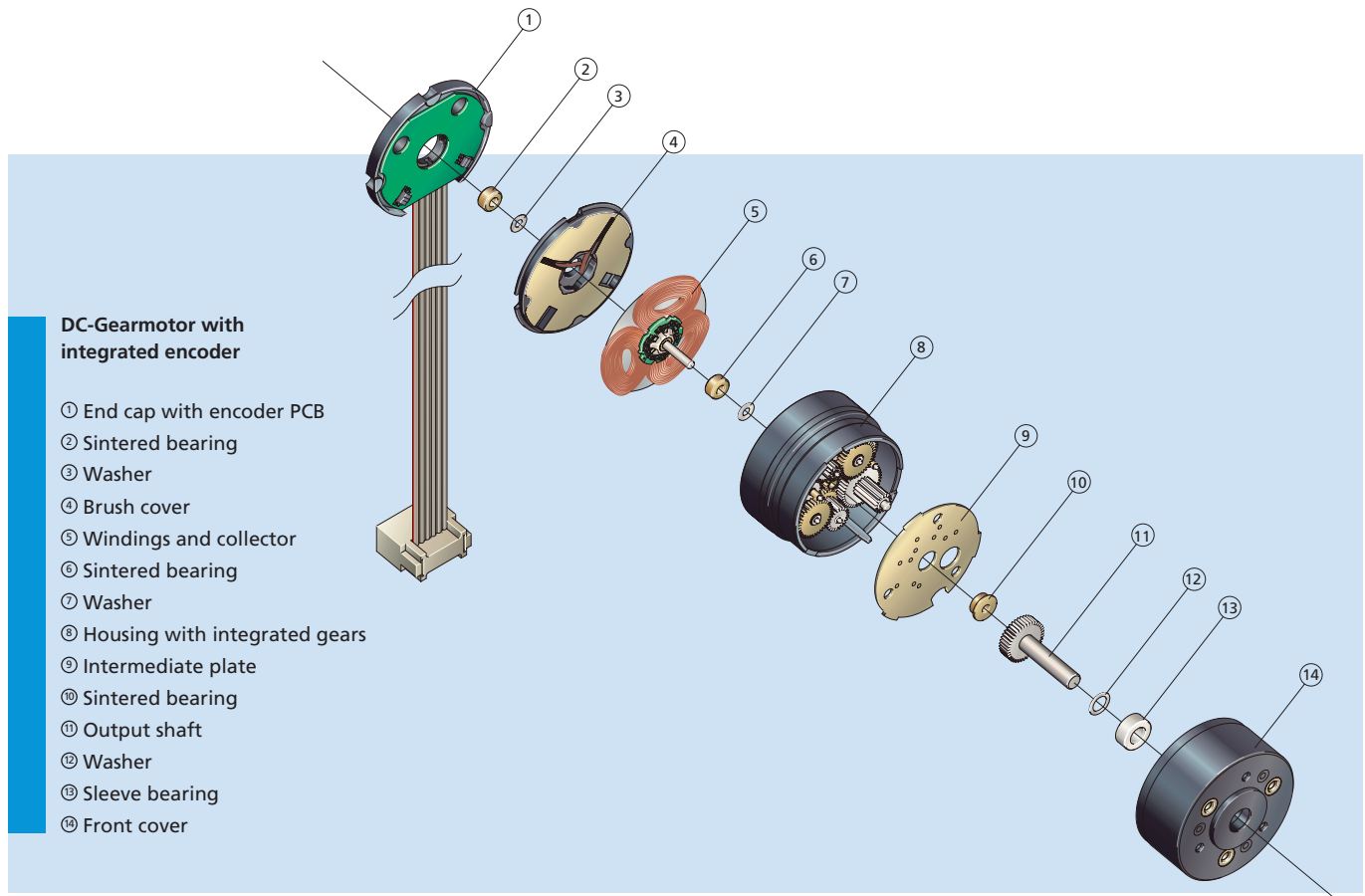

Features

The heart of these Flat DC-Micromotors is the ironless rotor made up of three flat self supporting windings. The rotor winding has exceptionally low inertia and inductance and rotates in an axial magnetic field.

Motor torque can be increased by the addition of an integrated reduction gearhead. This also reduces the speed to fit the specifications in the application.

FAULHABER specializes in the modification of their drive systems to fit the customer's particular application requirements. Common modifications include vacuum compatibility, extreme temperature compatibility, modified shaft geometry, additional voltage types, custom motor leads and connectors, and much more.

Benefits

- No cogging
- Extremely low current consumption – low starting voltage
- Highly dynamic performance due to a low inertia, low inductance winding
- Light and compact
- Precise speed control
- Simple to control due to the linear performance characteristics

Product Code



26	Motor diameter [mm]
19	Motor length [mm]
S	Shaft type
012	Nominal voltage [V]
S	Type of commutation (precious metal)
R	Version (rare earth magnet)

2619 S 012 SR

Brushless DC-Motors



Brushless DC-Servomotors

Technical Information

General Information

The FAULHABER winding:

Originally invented by Dr. Fritz Faulhaber Sr. and patented in 1958, the System FAULHABER coreless (or ironless) progressive, self-supporting, skew-wound rotor winding is at the heart of every FAULHABER DC-Motor. This revolutionary technology changed the industry and created new possibilities for customer application of DC-Motors where the highest power, best dynamic performance, in the smallest possible size and weight are required. Applied in a three phase brushless motor, the winding no longer rotates but rather becomes the basis of a slotless stator. The main benefits of this technology include:

- No cogging torque resulting in smooth positioning and speed control and higher overall efficiency than other brushless motor types
- Extremely high torque and high performance in relation to the size and weight of the motor
- Absolute linear relationship between load to speed, current to torque, and voltage to speed, with a highly sensitive current / torque behaviour
- Extremely low torque ripple

Brushless DC-Motor Types:

Whether it's high torque 4-pole DC-Servomotors, highly efficient flat DC-Micromotors, or compact slotless motors, FAULHABER specializes in getting the most performance out of the smallest package.

Due to their design FAULHABER Brushless DC-Motors are ideal for heavy duty servo applications with frequent overload conditions as well as for continuous duty applications where maximum operational lifetime is required.

FAULHABER high precision 2-pole Brushless DC-Motors are three phase slotless motors that have a wide speed and torque range and are ideal for mid- to high speed applications requiring smooth speed control, high efficiency, and long operational lifetimes.

For highly dynamic servo applications requiring very high torque in the most compact dimensions, the FAULHABER BX4 Series 4-pole, DC-Servomotors are ideal. Their robust design with very few parts and no glued components means that they are extremely durable and well suited for challenging ambient conditions such as extreme temperatures and high shock and vibration loads.

FAULHABER brushless flat DC-Micromotors are 3 phase, slotless, axial flux gap motors with a rotating back iron. They have a much higher efficiency than other flat brushless motors and their rotating back iron provides a high rotor inertia that is ideal for applications requiring low torque ripple and very precise continuous speed control.

FAULHABER also offers a range of 2-pole Brushless Motors with a cylindrical rotating back iron sometimes referred to as ironless outrunner motors. What sets the FAULHABER Motor apart is the slotless design which eliminates the cogging effect. The high inertia rotor makes these motors ideal for continuous duty applications requiring very precise speed control. These motors also have on-board speed control electronics that can be configured for different speed profiles.

Sensors:

FAULHABER 2-pole or 4-pole DC-Servomotors and Flat Brushless DC-Micromotors come standard with 3 digital Hall sensors with a 120° phase shift.

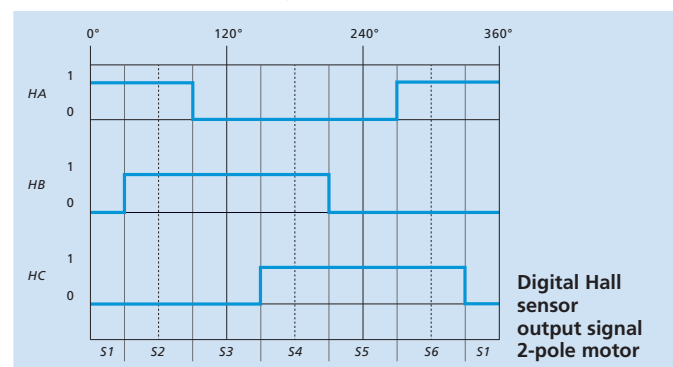

As an option, most FAULHABER Brushless DC-Servomotors are available with analogue (linear) Hall sensors.

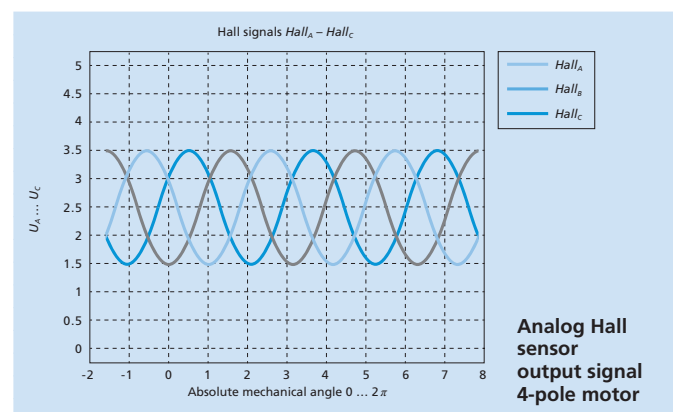

These sensors can replace the need for a high resolution encoder in many applications and provide the basic commutation signal for the Brushless DC-Servomotors in combination with FAULHABER Motion Controllers.

Magnets:

FAULHABER Brushless DC-Servomotors are designed with a variety of different types of magnets to suit the particular performance of the given motor type or application conditions. These materials include high performance rare earth magnet types such as SmCo and NdFeB.

Service life:

Due to the fact that motor commutation is achieved electronically and not mechanically, the operational lifetime of a FAULHABER Brushless DC-Servomotor depends mainly on the lifetime performance of the motor bearings. FAULHABER uses high precision preloaded ball bearings in all of its Brushless DC-Servomotors 6 mm in diameter and larger. Factors affecting the life of the motor bearings include the static and dynamic axial and radial bearing loads, the ambient thermal conditions, the motor speed, shock and vibrational loads, and the precision of the shaft coupling to the given application. If operated according to the data sheet Brushless DC-Servomotors have an operational lifetime many times that of mechanically commutated (brush) DC-Motors.

Modifications:

FAULHABER specialises in the adaptation of its standard products for customer-specific applications. Available modifications for FAULHABER Brushless DC-Servomotors include:

- Additional voltage types
- Connecting cables (PTFE and PVC) and plugs
- Configurable shaft lengths and second shaft ends
- Modified shaft dimensions and pinion configurations such as flats, gears, pulleys and eccenters
- Extended temperature range
- Vacuum compatibility (e.g. 10^{-7} Torr)
- Modifications for high speed and / or high load applications
- Modifications for high shock & vibration loads
- Autoclavable Motors
- Modifications for motors with tighter than standard electrical or mechanical tolerances

Product Combinations:

FAULHABER offers the industry's largest selection of complementary products tailor made for all of its Brushless DC-Servomotors including:

- Precision gearheads (planetary gearheads, spur gearheads and zero-backlash spur gearheads)
- High resolution Encoders (Incremental and Absolute)
- High Performance Drive Electronics (Speed Controllers, Motion Controllers)
- Integrated drive electronics (Motion and Speed Control)

Brushless DC-Servomotors

2 Pole Technology

Series 1628 ... B

Values at 22°C and nominal voltage		1628 T
1	Nominal voltage	U_N
2	Terminal resistance, phase-phase	R
3	Efficiency, max.	η_{max}
4	No-load speed	n_o
5	No-load current, typ. (with shaft \varnothing 1,5 mm)	I_o
6	Stall torque	
7	Friction torque	

Explanatory Notes for Data Sheets

The following values are measured or calculated at nominal voltage, without integrated drive electronics, at an ambient temperature of 22 °C.

Nominal voltage U_N [V]

This is the voltage applied between two winding phases using block commutation. This is the voltage at which the other data sheet parameters are measured or calculated. Depending on the required speed, higher or lower voltage can be applied to the motor within the given limits.

Terminal resistance, phase to phase R [Ω] ± 12 %

Is the resistance between two motor phases without an additional cable. This value will vary with the winding temperature (temperature coefficient: $\alpha_{22} = 0,004 \text{ K}^{-1}$).

Efficiency η_{max} [%]

The maximum ratio between the absorbed electrical power and the obtained mechanical power of the motor.

$$\eta_{max} = \left(1 - \sqrt{\frac{I_o \cdot R}{U_N}}\right)^2$$

No-load speed n_o [min^{-1}] ± 12 %

Describes the motor speed under no-load conditions at steady state and 22 °C ambient temperature. If not otherwise defined the tolerance for the no-load speed is assumed to be $\pm 12\%$.

$$n_o = \frac{U_N - (I_o \cdot R)}{2\pi \cdot k_M}$$

No-load current, typ. I_o [A]

Describes the typical current consumption of the motor without load at an ambient temperature of 22 °C after reaching a steady state condition.

The no-load current is speed and temperature dependent. Changes in ambient temperature or cooling conditions will influence the value. In addition, modifications to the

Brushless DC-Servomotors

Technical Information

shaft, bearing, lubrication, and commutation system or combinations with other components such as gearheads or encoders will all result in a change to the no-load current of the motor.

Stall torque M_H [mNm]

The torque developed by the motor at zero speed (locked rotor) and nominal voltage. This value may vary due to the magnet type and temperature and the temperature of the winding.

$$M_H = k_M \cdot \frac{U_N}{R} - C_o$$

Friction torque C_o [mNm]

The torque caused by static mechanical friction of the ball bearings and magnetic hysteresis of the stator.

Viscous damping factor C_V [mNm/min⁻¹]

This factor is made up of the torque due to the viscous friction of the ball bearings as well as the Foucault currents, caused by the cyclical changes in the magnetic field of the stator. These losses are proportional to the speed of the motor.

Speed constant k_n [min⁻¹/V]

The speed variation per Volt applied to the motor terminals at constant load.

$$k_n = \frac{n_o}{U_N - I_o \cdot R} = \frac{1}{k_E}$$

Back-EMF constant k_E [mV/min⁻¹]

The constant corresponding to the relationship between the induced voltage in the rotor and the speed of rotation.

$$k_E = 2\pi \cdot k_M$$

Torque constant k_M [mNm/A]

The constant corresponding to the relationship between the torque developed by the motor and the current drawn.

Current constant k_I [A/mNm]

Describes the relation of the current in the motor winding and the torque developed at the output shaft.

$$k_I = \frac{1}{k_M}$$

Slope of n-M curve $\Delta n / \Delta M$ [min⁻¹/mNm]

The ratio of the speed variation to the torque variation. The smaller the value, the more powerful the motor.

$$\frac{\Delta n}{\Delta M} = \frac{R}{k_M^2} \cdot \frac{1}{2\pi}$$

Terminal inductance, phase to phase L [μH]

The inductance measured between two phases at 1 kHz.

Mechanical time constant τ_m [ms]

The time required by the motor to reach a speed of 63 % of its final no-load speed, from standstill.

$$\tau_m = \frac{R \cdot J}{k_M^2}$$

Rotor inertia J [gcm²]

The dynamic moment of inertia of the rotor.

Angular acceleration α_{max} [rad/s²]

The acceleration obtained from standstill under no-load conditions and at nominal voltage.

$$\alpha_{max} = \frac{M_H}{J}$$

Thermal resistance R_{th1} ; R_{th2} [K/W]

R_{th1} corresponds to the thermal resistance between the winding and housing. R_{th2} corresponds to the thermal resistance between the housing and the ambient air. R_{th2} can be reduced by enabling exchange of heat between the motor and the ambient air (for example, a thermally coupled mounting configuration, using a heat sink, and / or forced air cooling).

Thermal time constant τ_{w1} ; τ_{w2} [s]

The thermal time constant specifies the time needed for the winding (τ_{w1}) and housing (τ_{w2}) to reach a temperature equal to 63% of final steady state value.

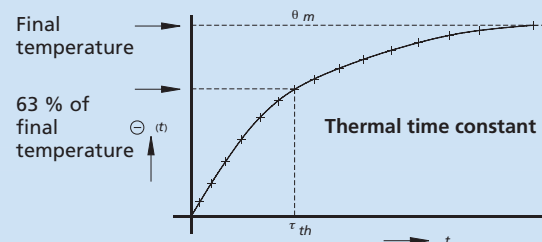

Operating temperature range [°C]

Indicates the minimum and maximum standard motor operating temperature, as well as the maximum allowable temperature of the standard motor winding.

Shaft bearings

The bearings used for the Brushless DC-Servomotor.

Shaft load max. [N]

The output shaft load at a specified shaft diameter for the primary output shaft. For motors with ball bearings the load and lifetime are in accordance with the values given by the bearing manufacturers. This value does not apply to second, or rear shaft ends.

Shaft play [mm]

The play between the shaft and bearings, including the additional bearing play in the case of ball bearings.

Housing material

The housing material and the surface protection.

Mass [g]

The average mass of the basic motor type.

Direction of rotation

Most motors are designed for clockwise (CW) and counter-clockwise (CCW) operation; the direction of rotation is reversible. The direction of rotation is given by the external servo amplifier.

Please note that for motors with integrated electronics, the direction of rotation may not be reversible.

Speed up to n_{max} [min^{-1}]

The maximum recommended motor speed for continuous operation at a given cooling level. This value is based on the recommended operating range for the standard motor bearings and the winding. All higher values have negative effects on the maximum achievable service life of the motor.

Number of pole pairs

Indicates the number of pole pairs of the standard motor.

Hall sensors

Describes the type of motor commutation feedback components in the standard motor.

Magnet material

Describes the basic type of the magnet used in the standard motor.

Unspecified mechanical tolerances:

Tolerances in accordance with ISO 2768.

$\leq 6 = \pm 0,1 \text{ mm}$

$\leq 30 = \pm 0,2 \text{ mm}$

$\leq 120 = \pm 0,3 \text{ mm}$

The tolerances of non-specified values are available on request.

All mechanical dimensions related to the motor shaft are measured with an axial preload of the shaft toward the motor.

Rated Values for Continuous Operation

The following values are measured at nominal voltage, without integrated drive electronics, at an ambient temperature of 22 °C.

Rated Torque M_N [mNm]

The maximum continuous duty torque (S1 Operation) at nominal voltage resulting in a steady state temperature not exceeding either the maximum winding temperature and/or operating temperature range of the motor. The motor is specified with a 25 % reduction of the R_{th2} value, which roughly corresponds to the cooling of the motor in a typical installation situation. This value can be exceeded if the motor is operated intermittently, for example, in S2 mode and/or if more cooling is applied.

Rated Current (thermal limit) I_N [A]

The typical maximum continuous current at steady state resulting from the rated continuous duty torque. This value includes the effects of a loss of k_M (torque constant) as it relates to the temperature coefficient of the winding, losses due to the effects of the dynamic coefficient of friction which include the Foucault (eddy current) losses, as well as the thermal characteristics of the given magnet material. This value can be exceeded if the motor is operated intermittently, in start/stop mode, in the starting phase and/or if more cooling is used.

Rated Speed n_N [min^{-1}]

The typical speed at steady state resulting from the application of the given rated torque. This value includes the effects of motor losses on the slope of the n/M curve.

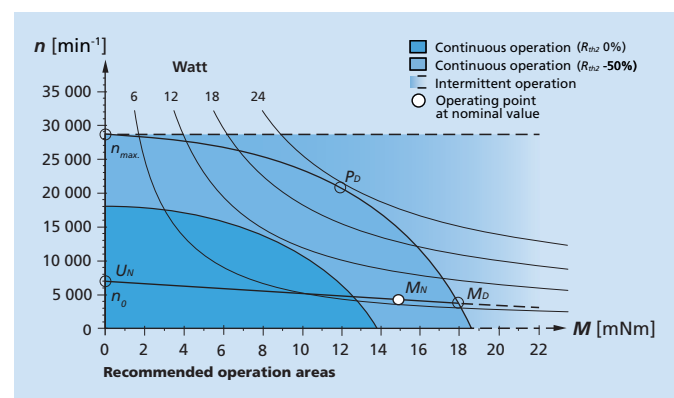

Example: Power diagram for rated values at continuous operation.

Brushless DC-Servomotors

Technical Information

Explanations on the Performance Diagram

The performance diagram shows the range of possible operating points of a drive at an ambient temperature of 22 °C and includes both the operation in the thermally insulated and in the cooled state. The possible speed ranges are shown in dependence on the shaft torque.

The sector shown dashed describes potential operating points in which the drive can be engaged in intermittent operation or with increased cooling.

Continuous torque M_D [mNm]

Describes the max. continuous torque in the steady state at nominal voltage and with a thermal reduction of the $R_{th\ 2}$ value by 50 %. The continuous speed decreases linearly vis-à-vis the continuous torque. The continuous torque is independent of the continuous output power and can be exceeded if the motor is operated intermittently, for example, in S2 operation and/or if more cooling is applied.

Continuous output power P_D [W]

Describes the max. possible output power in continuous operation in steady state with a thermal reduction of the $R_{th\ 2}$ value by 50 %. The value is independent of the continuous torque, responds linearly to the cooling factor and can be exceeded if the motor is operated intermittently, for example, in S2 operation and/or if more cooling is applied.

Nominal voltage curve U_N [V]

The nominal voltage curve describes the operating points at U_N in the uncooled and cooled state. In steady state, the starting point corresponds to the no-load speed n_0 of the drive. Operating points above this curve can be attained by an increase, operating points below by a reduction of the nominal voltage.

Brushless DC-Servomotors

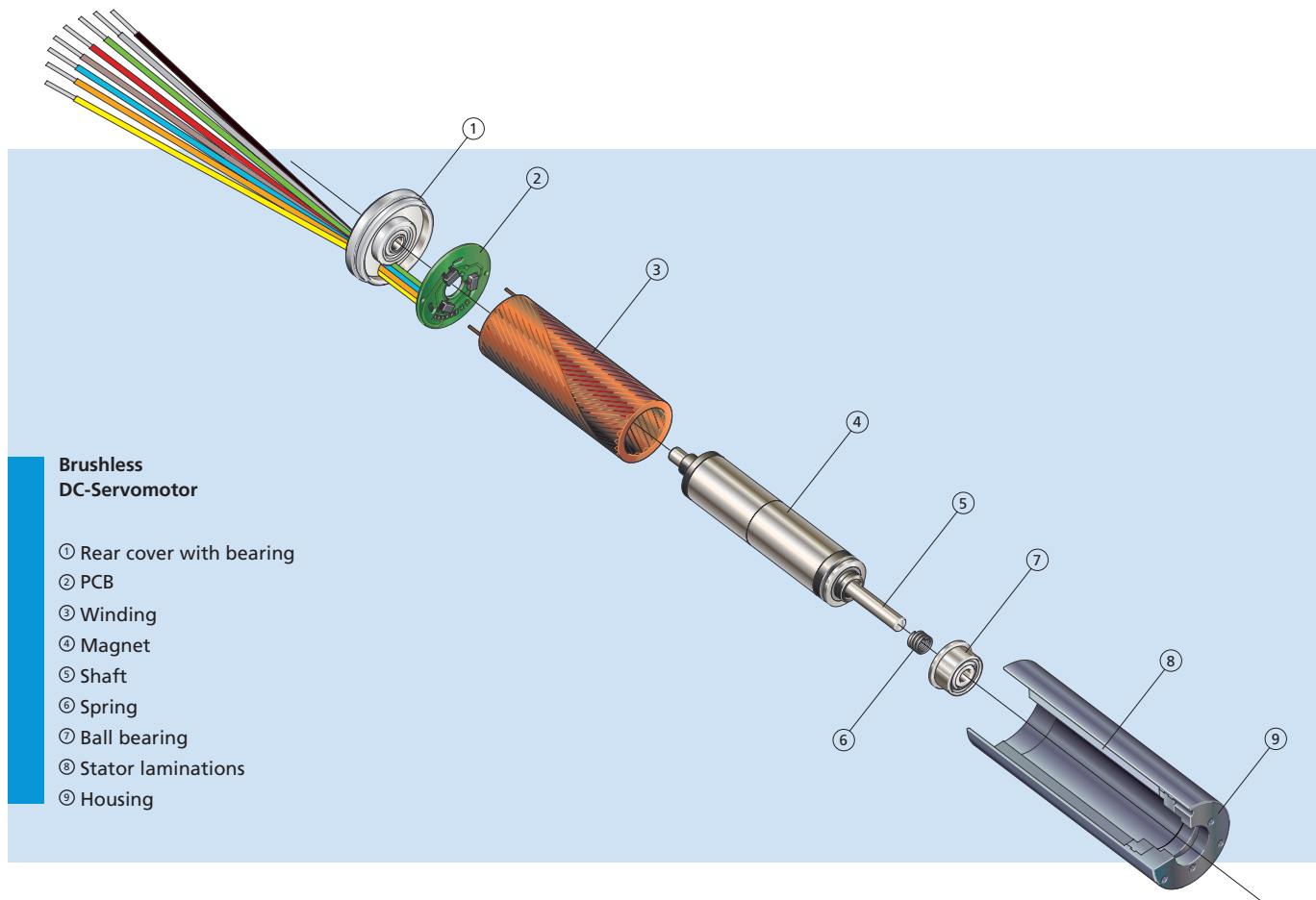

Features

The FAULHABER Brushless DC-Servomotors are built for extreme operating conditions. They are precise, have extreme long lifetimes and are highly reliable. Exceptional qualities such as smooth running and especially low noise level are of particular note. The rare-earth magnet as rotor, and FAULHABER skew winding technology ensure that these motors deliver top performance dynamics within minimum overall dimensions.

This series is also available in an autoclavable version and is ideally suited for application in laboratory and medical equipment.

Sterilizing conditions

- Temperature 134 °C ± 2 °C
- Water vapour pressure 2,1 bar
- Relative humidity 100 %
- Duration of cycle 20 min.
- Rated for a minimum of 100 cycles

Benefits

- System FAULHABER®, ironless stator winding
- High reliability and operational lifetime
- Wide range of linear torque / speed performance
- No sparking
- No cogging
- Dynamically balanced rotor
- Simple design
- Standard with digital Hall sensors with optional analogue Hall sensors

Product Code



Brushless DC-Servomotors

4 Pole Technology

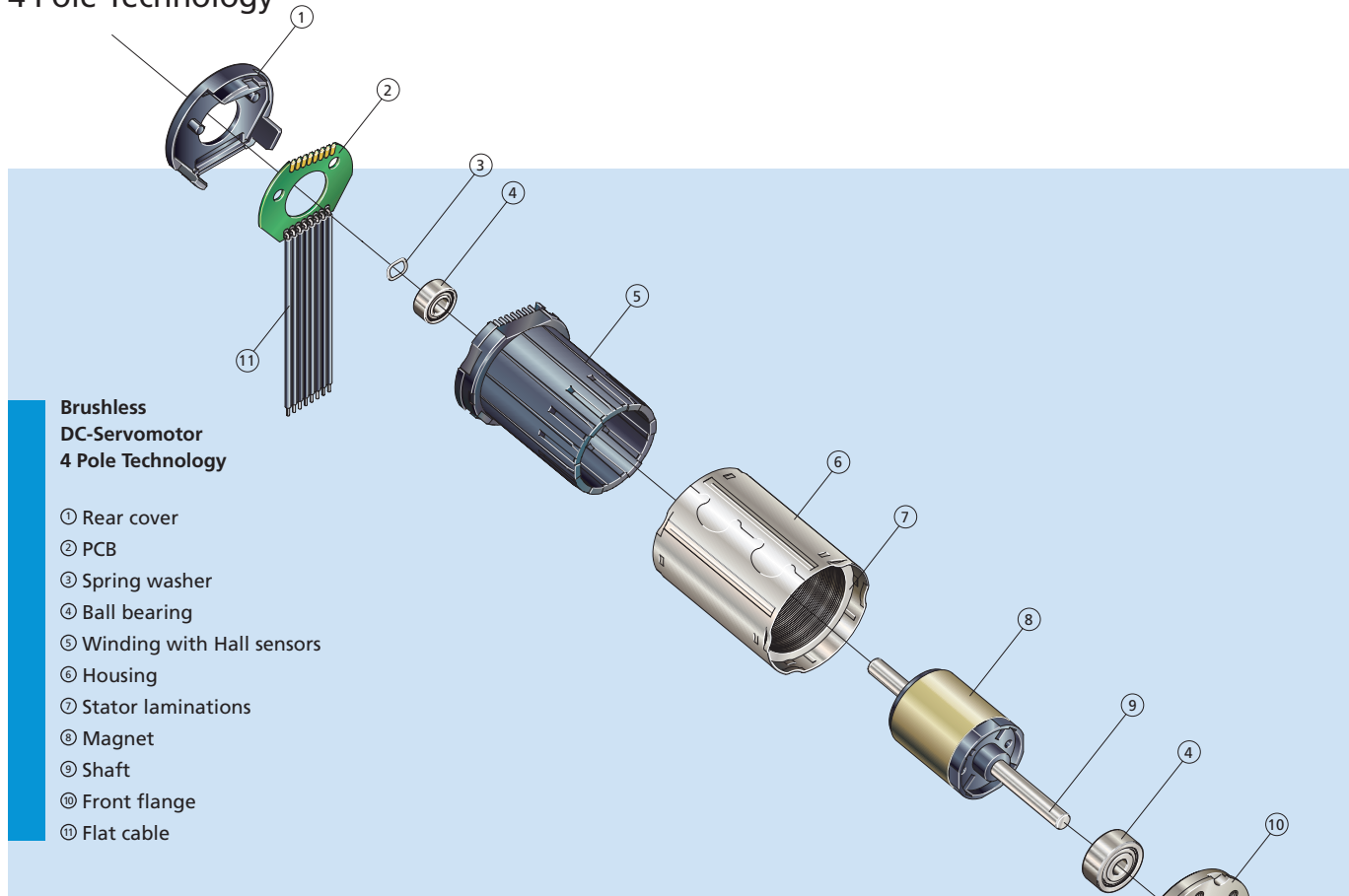

Features

The brushless servo motors in the FAULHABER BX4 series are characterised by their innovative design, which comprises just a few individual components.

Despite their compact dimensions, the 4 pole magnet technology gives these drives a high continuous torque with smooth running characteristics and a particularly low noise level. The modular rotor system makes it possible to tune the performance of the motor to the higher torque or higher speed needs of the application.

Thanks to the electronic commutation of the drives, the lifetime is much longer in comparison with mechanically commutated motors. Alongside the basic version in which the commutation is provided by an external control. The motors come standard with digital Hall sensors.

Due to the optional use of analog Hall sensors, stable regulation of low rotational speeds is also possible without the need for an additional encoder. The flexible motor concept of the BX4 series also includes versions with an integrated encoder, Speed Controller or Motion Controller.

Benefits

- High torque 4 Pole Technology
- Compact, robust design
- Modular concept
- Also available as a diameter-compliant version with an integrated encoder, Speed Controller or Motion Controller
- High reliability and operational lifetime
- No sparking
- No cogging
- Dynamically balanced rotor

Product Identification



22	Motor diameter [mm]	22
32	Motor length [mm]	32
5	Shaft type	5
012	Nominal Voltage [V]	012
BX4	Type of commutation (brushless), 4 Pole Technology	BX4

2232 S 012 BX4

Brushless DC-Servomotors

4 Pole Technology, High Power

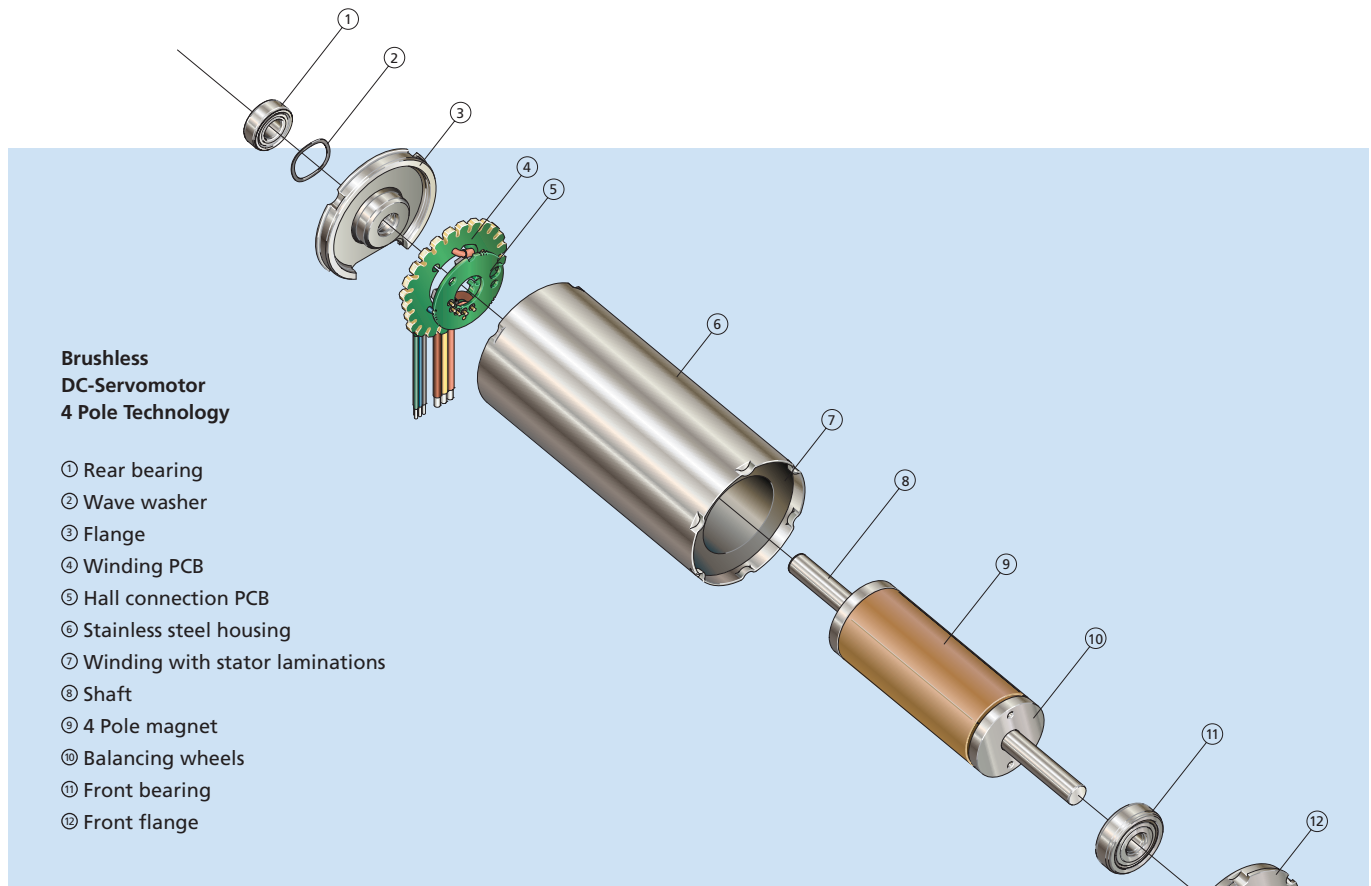

Features

The four-pole brushless DC servomotor is ideal for applications in which high power and dynamic start/stop operation with the lowest possible total weight is an important factor.

The series BP4 is overload-resistant and its operational lifetime is many times longer than that of a conventional DC-Micromotor. The motors can reliably deliver what the application demands even under the harshest ambient conditions, such as at low temperatures or high mechanical loads. This is made possible by, among other things, a robust stainless steel housing and the omission of adhesives used for assembly.

One particularly interesting feature of this motor series is the high flexibility in its design. The series BP4 is equipped as standard with digital hall sensors, alternatively analog. High-resolution optical and magnetic encoders can be attached simply to the rear multifunction flange. Finally, a large selection of performance-optimised precision gear-heads rounds off the complete drive system.

Benefits

- Innovative winding technology
- Significant improvement in electrical and geometrical winding symmetry
- High efficiency due to minimized losses
- Flexible sensor concept
- Extended temperature range
- Highest possible torque to weight ratio

Product Identification

32	Motor diameter [mm]
74	Motor length [mm]
G	Shaft type
024	Nominal Voltage [V]
BP4	Type of commutation (brushless), 4 Pole Technology

3274 G 024 BP4

Brushless Flat DC-Micromotors

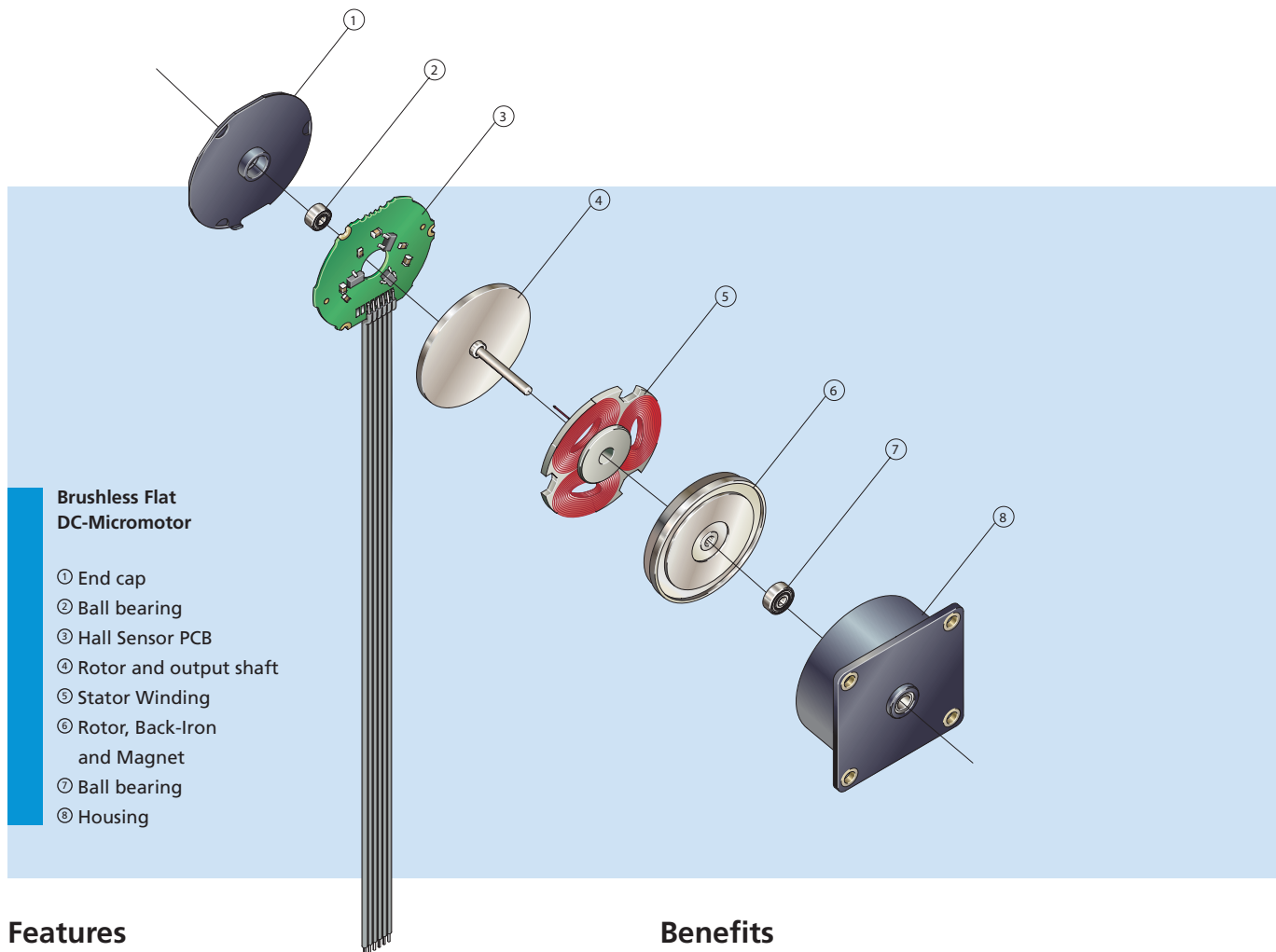

Features

The heart of each brushless flat DC-Motor consists of the flat stator windings. The rotor is constructed of a high power rare earth magnet and two rotating discs which provide the back iron for an optimal use of the magnetic flux.

The rotating back iron also serves to eliminate any cogging, or so-called detent torque which improves the inherent speed control properties of the motor drastically.

Thanks to the brushless commutation the motors can reach much higher operational lifetimes than conventional mechanically commutated DC-Motors.

Motor torque can be increased and motor speed reduced by the addition of an integrated reduction gearhead. The revolutionary integrated design provides for a wide variety of reduction ratios while maintaining a very flat profile.

Benefits

- No cogging torque
- Electronic commutation using three digital Hall sensors
- Precise speed control
- Flat, light, and very compact

Product Identification



26	Motor diameter [mm]
10	Motor length [mm]
T	Shaft type
012	Nominal Voltage [V]
B	Type of commutation (electronic)

26 10 T 012 B

Brushless DC-Motors with integrated Electronics

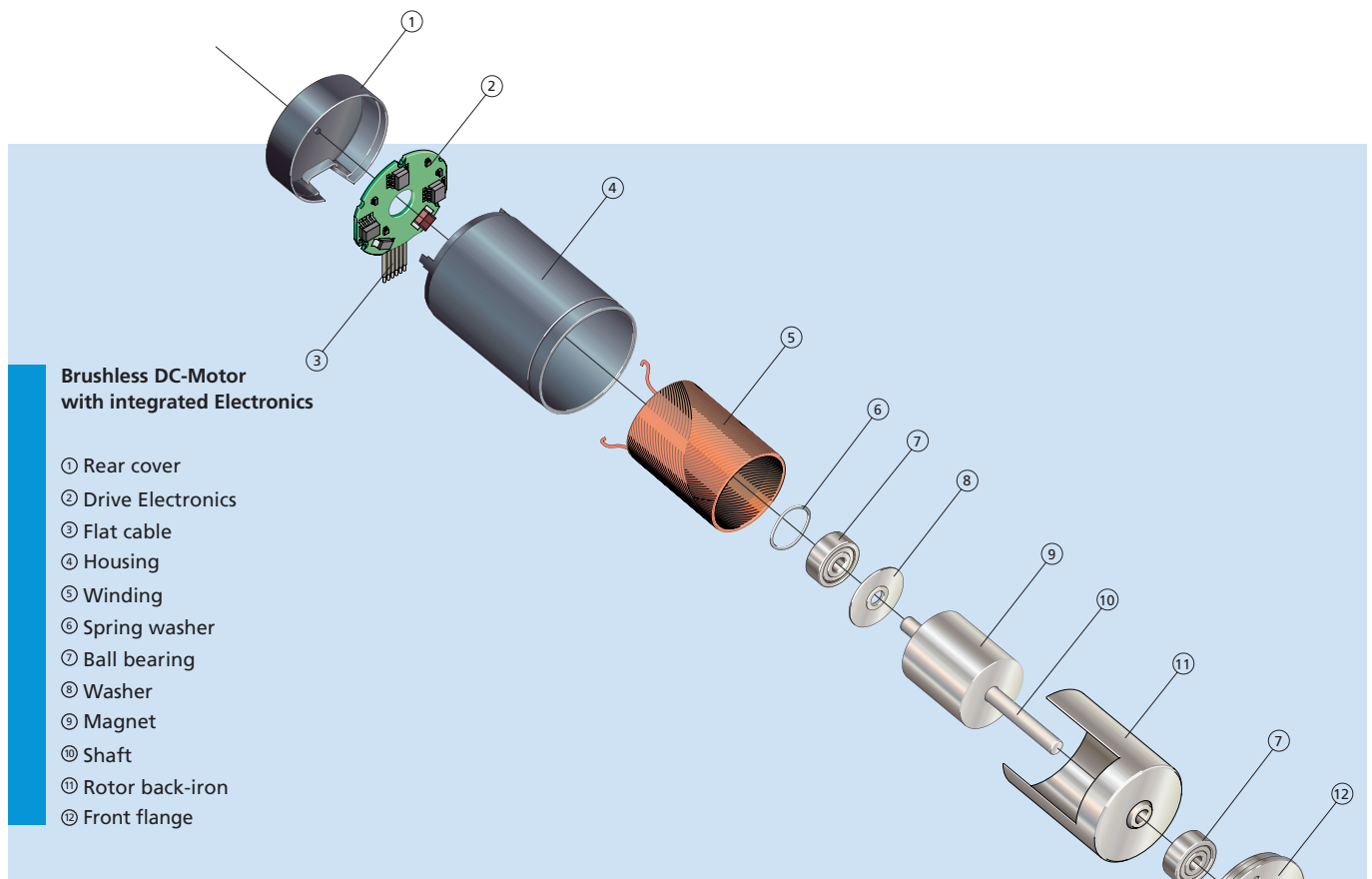

Features

These brushless DC-motors with integrated electronics combine the advantages of coreless winding technology with those of electronic commutation.

The motors are based on self-sustaining winding technology, System FAULHABER®, and primarily consist of a three-phase winding and a two-pole permanent magnet as well as the electronic commutation system.

For detecting the position of the rotor in relation to the rotating field of the winding, the retroactive generator voltage (EMK) is measured and evaluated. The rotor position is detected without sensors. Eddy current loss in the motor is prevented by the back iron rotating with the magnets.

Benefits

- Outstanding reliability, long service life
- Wide, more linear speed/torque range
- Programmable motor characteristics
- No sparking
- No clogging torque
- Coreless winding technology, System FAULHABER®
- Brushless commutation
- Position detection without sensors
- Integrated electronics
- Dynamically balanced rotor, quiet running

Product Identification



31	Motor diameter [mm]
53	Motor length [mm]
K	Shaft type
012	Nominal Voltage [V]
BRC	Type of commutation (brushless), with integrated electronics

3153 K 012 BRC

Brushless DC-Motors with integrated Speed Controller

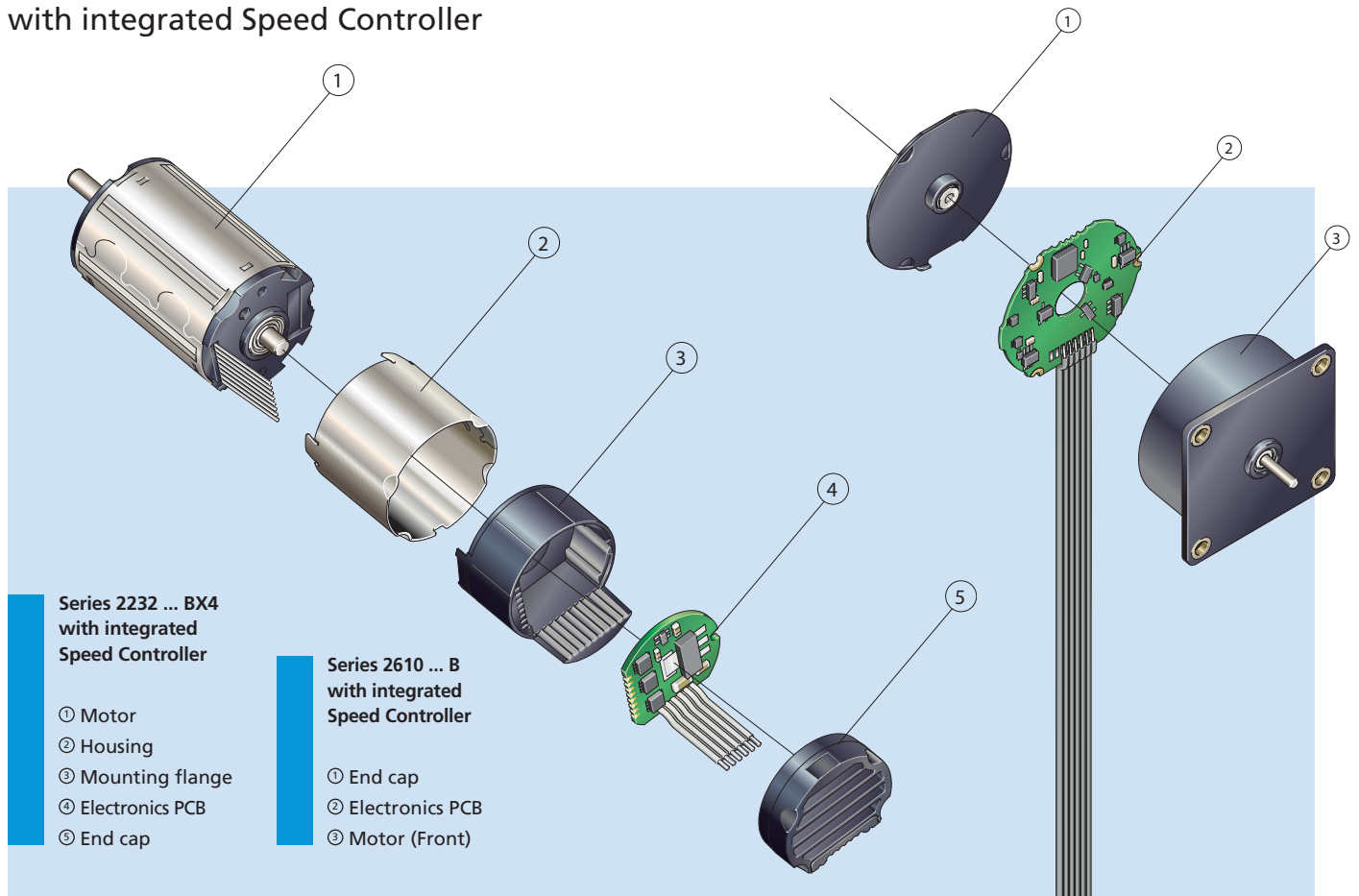

**Series 2232 ... BX4
with integrated
Speed Controller**

- ① Motor
- ② Housing
- ③ Mounting flange
- ④ Electronics PCB
- ⑤ End cap

**Series 2610 ... B
with integrated
Speed Controller**

- ① End cap
- ② Electronics PCB
- ③ Motor (Front)

Features

These new brushless DC-Motors combine the advantages of a slotless brushless motor with dedicated, high precision, speed control electronics.

Speed control is achieved using the on board PI controller with an external command voltage. The drives are protected from overload with the integrated current limiting.

The control parameters of the drive electronics can be modified to fit the application using our optional programming adapter and the easy to use FAULHABER Motion Manager software.

Many drives are also available in a simple 2 wire configuration for ease of integration or replacement of standard DC-Motors in some applications.

Benefits

- Integrated drive electronics
- Extremely compact
- Very robust construction
- Easy to use
- Integrated current limiting
- Control parameters can be tuned to the application

Product Identification



32 68 G 024 BX4 SC

32	Motor diameter [mm]
68	Motor length [mm]
G	Shaft type
024	Nominal Voltage [V]
BX4	Type of commutation (electronic)
SC	Integrated Speed Controller

Motion Control Systems



Motion Control Systems

Technical Information

Terminal Variations

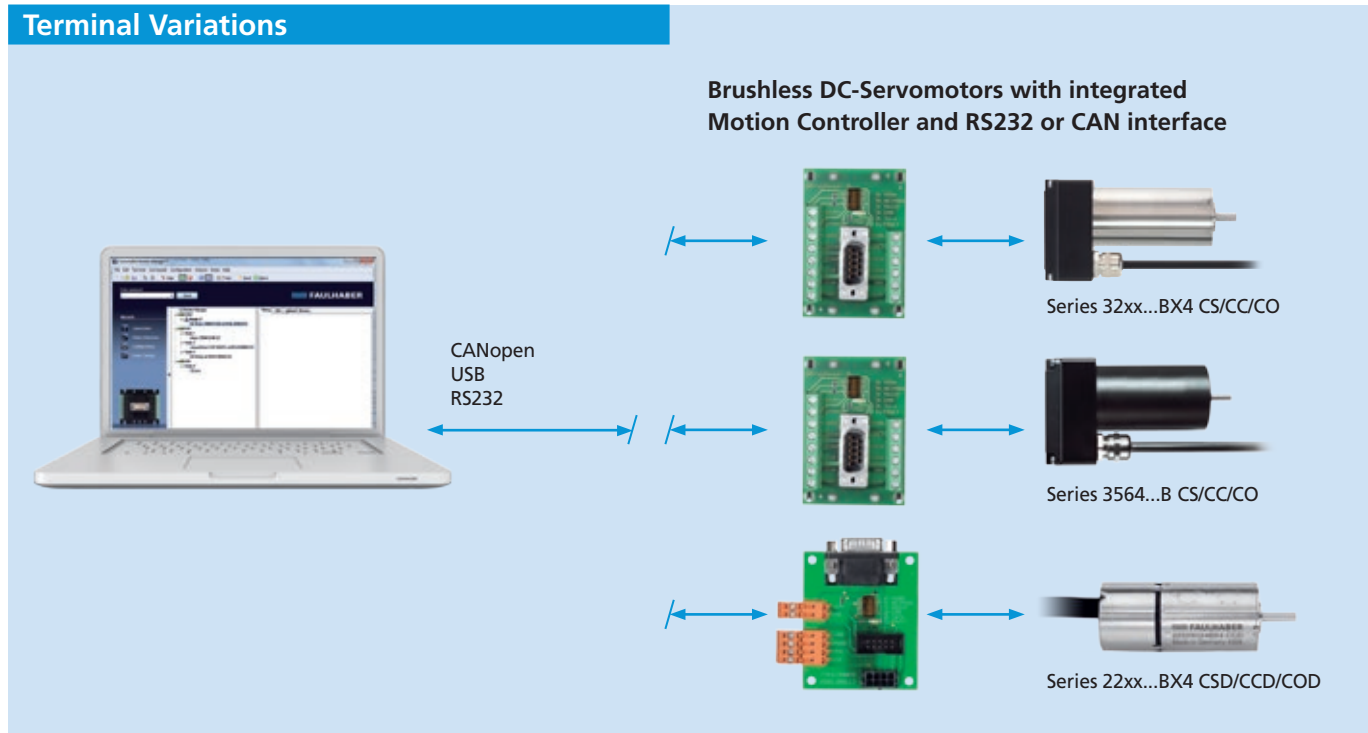

Features

FAULHABER Motion Controllers are highly dynamic positioning systems tailored specifically to the requirements of micromotor operations.

In addition to being deployed as a positioning system, they can also operate as speed or current controllers.

The drives can be supplied with an RS232 interface or with a CAN interface and CANopen protocol.

Using this technology, up to 127 drives can be interconnected and controlled with maximum efficiency.

Motion Control Systems – highly dynamic, low-maintenance BLDC servomotors with integrated motion control functionality – deliver the ultimate in slimline design. The integrated systems require less space, as well as making installation much simpler thanks to their reduced wiring.

Benefits

- Compact construction
- Modular design, various performance ratings
- Minimal wiring
- Parametrization via „FAULHABER Motion Manager“ software
- Extensive accessories
- Adapter for connection to USB interface

Product Code



3268	motor series
G	shaft type
024	nominal voltage
BX4	electronic commutation brushless
CS	Serial interface RS232

3268 G 024 BX4 CS

Motion Control Systems

Configuration, Networking, Interfaces

Operating Modes

Speed control

PI speed controls, even for demanding synchronization requirements.

Positioning

For moving to defined positions with a high level of resolution. Using a PD Controller, the dynamic response can be adjusted to suit the application. Reference and limit switches are evaluated by means of various homing modes.

Speed profiles

Acceleration ramps, deceleration ramps and maximum velocity can also be defined for each section. As a result, even complex profiles can be implemented quickly and effectively.

Current control

Protects the drive by limiting the motor current to the set peak current. The current is limited to the continuous current by means of integrated I²t monitoring if required.

Protective features

- Protection against ESD
- Overload protection for electronics and motor
- Self-protection from overheating
- Overvoltage protection in generator mode

Extended operating modes

- Stepper motor mode
- Gearing mode
- Position control to analog set point
- Operation as servo amplifier in voltage adjuster mode
- Torque/force controller using variable set current input

Options

Separate supply of power to the motor and electronic actuator is optional (important for safety-critical applications). No third input is required in such cases. Depending on the drive, additional programming adapters and connection aids are available. The modes and parameters can be specially pre-configured on request.

Interfaces - Discrete I/O

Setpoint input

Depending on the operating mode, setpoints can be input via the command interface, via an analog voltage value, a PWM signal or a quadrature signal.

Error output (Open Collector)

Configured as error output (factory setting). Also usable as digital input, free switch output, for speed control or signaling an achieved position.

Additional digital input

For evaluating reference switches.

Networking

FAULHABER Motion Controllers are available with three different interfaces.

RS: This indicates a system with an RS232 interface. It is ideal for applications that do not use a higher level controller. Operation is made simple through the use of a plain text command set which can be used to generate scripts and programs that can run autonomously on the controller itself.

CF: This indicates a system with a FAULHABER CAN interface. This version contains the CiA 402 commands and includes the RS232 interface commands which are translated into simple to use CAN commands. This version is intended as a user friendly, simple to use bridge into to the complex use of CAN communications. A CAN master is always required when using this version.

CO: This indicates a system with a CANopen interface. This version is ideal when integrating a FAULHABER motion controller into a system with a PLC, either directly or through the use of a gateway. All parameter settings are made via the object directory. Configuration is possible through the use of the FAULHABER Motion Manager 5.0 or better, or standard CAN configuration tools.

Motion Control Systems

Configuration, Networking, Interfaces

Interfaces – Bus Connection

Version with RS232

For coupling to a PC with a transfer rate of up to 115 kbaud. Multiple drives can be connected to a single controller using the RS232 interface. As regards the control computer, no special arrangements are necessary. The interface also offers the possibility of retrieving online operational data and values.

A comprehensive ASCII command set is available for programming and operation. This can be preset from the PC using the „FAULHABER Motion Manager“ software or from another control computer.

Additionally, there is the possibility of creating complex processes from these commands and storing them on the drive. Once programmed as a speed or positioning controller via the analog input, as step motor or electronic gear unit, the drive can operate independently of the RS232 interface.

Versions with CAN CF or CO

Two controller versions with a CANopen interface are available for optimal integration within a wide range of applications. CANopen is the perfect choice for networking miniature drives because the interface can also be integrated into small electronics. Due to their compact size and efficient communication methods, they are the ideal solution for complex fields of application such as industrial automation.

CF version: CANopen with FAULHABER channel

The CF version supports not only CiA 402 standard operating modes but also a special FAULHABER Mode. Via PDO2, operator control is thus analogous to that of the RS232 version. Extended operating modes such as operation with analog setpoint input or the stepper or gearing mode are also supported. The CF version is therefore particularly suitable for users who are already familiar with the RS232 version and wish to exploit the benefits of CAN in networking.

CO version: pure CANopen

The CO version provides the CiA 402 standard operating modes. All the parameters are directly stored in the object directory. Configuration can therefore be performed with the help of the FAULHABER Motion Manager or by applying available standardized configurations tools common to the automation market. The CO version is particularly suitable for users who already use various CANopen devices or operate the Motion Controllers on a PLC. With dynamic PDO mapping it is possible to achieve highly efficient networking on the CAN.

CF / CO comparison

	CF	CO
NMT with node guarding	•	•
Baud rate	1 Mbit max., LSS	1 Mbit max, LSS
EMCY object	•	•
SYNCH Objekt	•	•
Server SDO	1x	1x
PDOs	3 x Rx 3 x Tx each with static mapping	4 x Rx 4 x Tx each with dynamic mapping
PDO ID	fixed	adjustable
Configuration	Motion Manager	Motion Manager from V5
Trace	PDO3 (fixed)	Any PDO
Standard operating modes	•	•
- Profile Position Mode - Profile Velocity Mode - Homing		
Ext. operating modes	FAULHABER channel	-

Both versions support the CANopen communication profile to CiA 301 V4.02. The transfer rate and node number are set via the network in accordance with the LSS protocol conforming to CiA 305 V1.11.

For this purpose, we recommend using the latest version of the FAULHABER Motion Manager.

Notes

Device manuals for installation and start up, communication and function manuals, and the „FAULHABER Motion Manager“ software are available on request and on the Internet at www.faulhaber.com.

Motion Control Systems

Technical Information

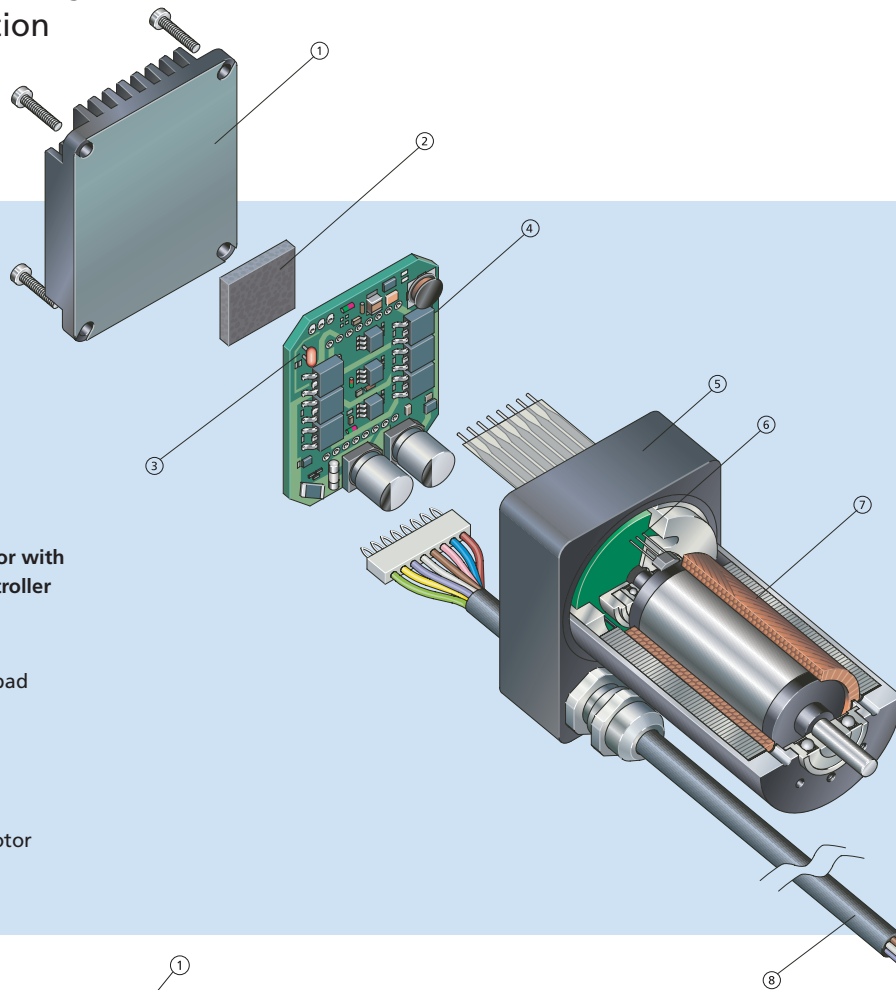

Brushless DC-Servomotor with integrated Motion Controller

- ① Heat sink/cover
- ② Thermal conduction pad
- ③ Thermal protection
- ④ Motion Controller
- ⑤ Housing
- ⑥ Analog Hall sensors
- ⑦ Brushless DC-Servomotor
- ⑧ Interface cable

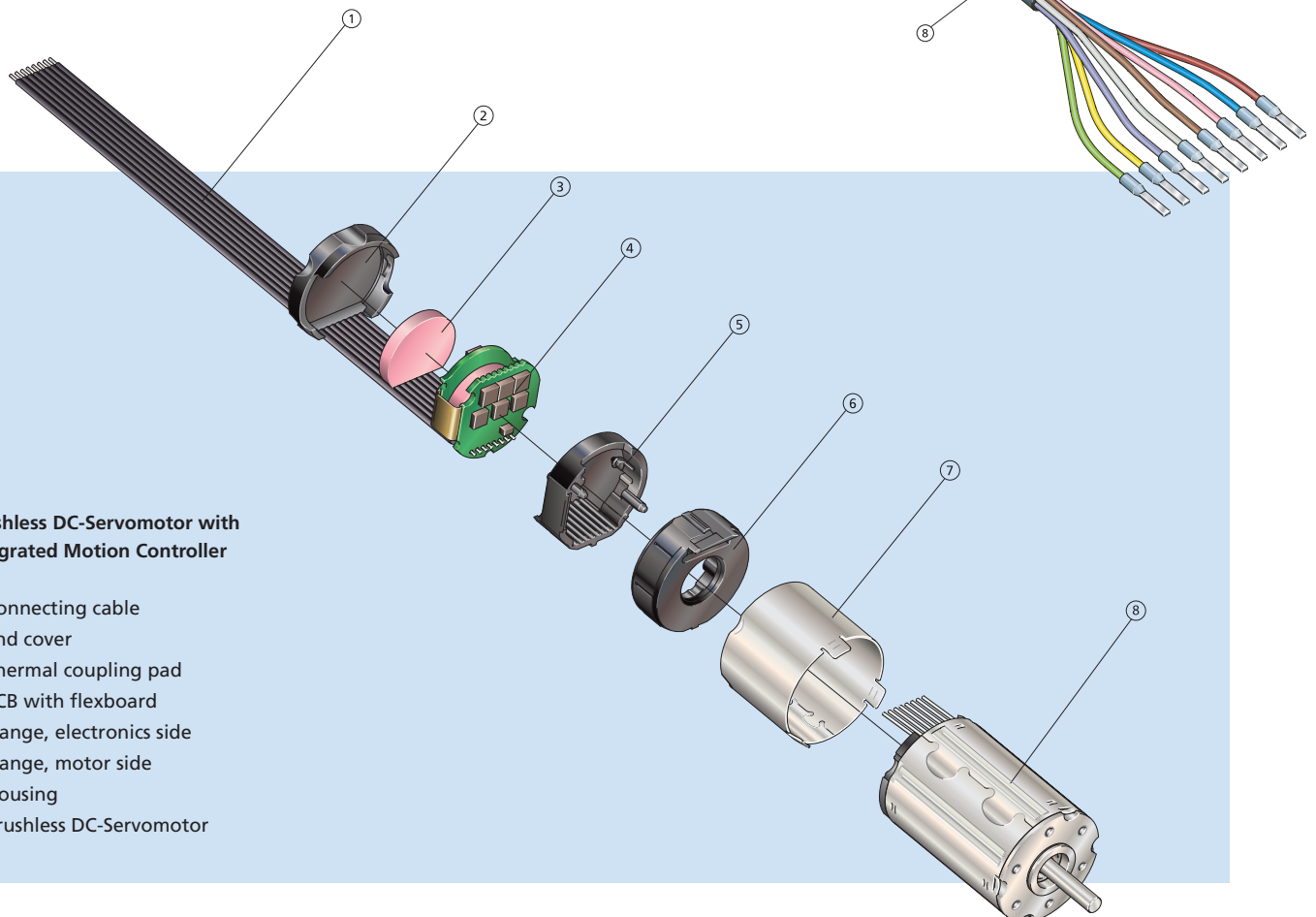

Brushless DC-Servomotor with integrated Motion Controller

- ① Connecting cable
- ② End cover
- ③ Thermal coupling pad
- ④ PCB with flexboard
- ⑤ Flange, electronics side
- ⑥ Flange, motor side
- ⑦ Housing
- ⑧ Brushless DC-Servomotor

Stepper Motors



Stepper Motors

Technical Information

Stepper Motors	
Two phase, 24 steps per revolution PRECstep® Technology	
AM2224-ww-ee	
	ww = A
	Current
1 Nominal current per phase (both phases ON) ¹⁾	1,0
2 Nominal voltage per phase (both phases ON) ¹⁾	-
3 Phase resistance (at 20°C)	
4 Phase inductance (at 20°C)	

Notes on technical data

Nominal current per phase [A]

The current supplied to both phases windings at an ambient temperature of 20 °C that will not exceed the thermal limits of the motor.

Nominal voltage per phase [V]

The voltage necessary to reach the nominal current per phase, measured at an ambient temperature of 20 °C.

Phase resistance ¹⁾ [Ω]

The winding resistance per phase at an ambient temperature of 20 °C. Tolerance +/- 12%, steady state.

Phase inductance [mH]

The winding inductance per phase measured at 1kHz.

Back-EMF amplitude ¹⁾ [V/k step/s]

The amplitude of the back-EMF measured at 1000 steps/s.

Holding torque (at nominal current in both phases) [mNm]

Is the torque of the motor at nominal current with two phases on.

Holding torque (at twice the nominal current) [mNm]

Is the torque of the motor at 2 x nominal current with two phases on. The magnetic circuit of the motor will not be affected by this boost current, however, to avoid thermal overload the motor should only be boosted intermittently. Ideally, the duty cycle should be reduced to 25% to avoid damage to the motor.

Step angle (full step) [degree]

Number of angular degrees the motor moves per full-step.

Angular accuracy [% of full step]

The percentage position error per full step, at no load, with identical phase current in both phases. This error is not cumulative between steps.

Residual torque, max. ¹⁾ [mNm]

The maximum torque applied to the shaft to rotate the shaft without current to the motor.

Residual torque is useful to hold a position without any current to save battery life or to reduce heat.

Rotor inertia [kgm²]

This value represents the inertia of the complete rotor.

Resonance frequency (at no load) [Hz]

The step rate at which the motor at no load will demonstrate resonance. The resonance frequency is load dependent. For the best results the motor should be driven at a higher frequency or in half-step or microstepping mode outside of the given frequency.

Electrical time constant [ms]

Is the time needed to establish 67% of the max. possible phase current under a given operation point.

Ambient temperature range [°C]

Temperatures at which the motor can operate.

Winding temperature tolerated max. [°C]

Maximum temperature supported by the winding and the magnets.

Thermal resistance R_{th1} ; R_{th2} [K/W]

R_{th1} corresponds to the value between the coil and the housing R_{th2} corresponds to the value between the housing and the ambient air R_{th2} can be reduced by enabling exchange of heat between the motor and the ambient air (for example using a heat sink or forced air cooling).

Thermal time constant τ_{w1} ; τ_{w2} [s]

The thermal time constant specifies the time needed for the winding respectively the housing to reach a temperature equal to 63% of the final value.

Shaft bearings

Self lubricating sintered sleeve bearings or preloaded ball bearings are available.

Shaft load, max. radial [N]

The maximum recommended radial shaft load for all bearing types.

Shaft load, max. axial [N]

The maximum recommended axial shaft load for all bearing types. For ball bearings this value corresponds to the axial preload. If this value is exceeded, irreversible displacement of the shaft may occur. The allowable axial travel of the shaft without damage to the motor is approximately 0,2mm.

Shaft play max., radial [μm]

The maximum clearance between shaft and bearing tested with the indicated force to move the shaft.

Shaft play max., axial [μm]

Represents the maximum axial play tested with the indicated force.

Mass [g]

Is the motor weight in grams.

¹⁾ These parameters are measured during final inspection on 100 % of the products delivered.

Stepper Motor Selection

The selection of a stepper motor requires the use of published torque speed curves based on the load parameters.

It is not possible to verify the motor selection mathematically without the use of the curves.

To select a motor the following parameters must be known:

- Motion profile
- Load friction and inertia
- Required resolution
- Available space
- Available power supply voltage

1. Definition of the load parameters at the motor shaft

The target of this step is to determine a motion profile needed to move the motion angle in the given time frame and to calculate the motor torque over the entire cycle using the application load parameters such as friction and load inertia.

The motion and load profiles of the movement used in this example are shown below:

Depending on the motor size suitable for the application it is required to recompute the load parameters with the motor inertia as well.

In the present case it is assumed that a motor with an outside diameter of maximum 15 mm is suitable and the data has been computed with the inertia of the AM1524.

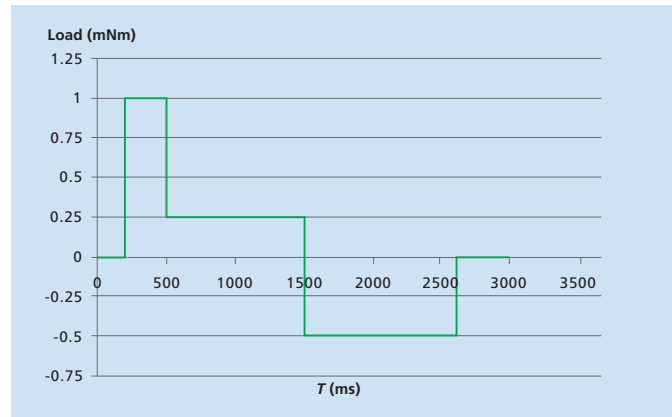
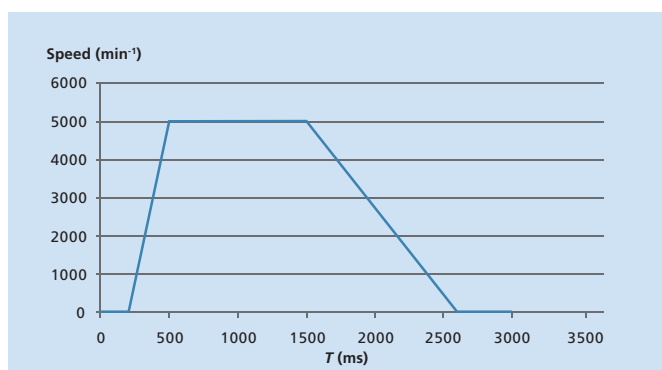

2. Verification of the motor operation.

The highest torque/speed point for this application is found at the end of the acceleration phase. The top speed is then $n = 5000 \text{ min}^{-1}$, the torque is $M = 1 \text{ mNm}$.

Using these parameters you can transfer the point into the torque speed curves of the motor as shown here with the AM1524 curves.

To ensure the proper operation of the motor in the application, it is highly recommended to use a safety factor of 30% during the torque calculation. The shown example assures that the motor will correctly fulfil the requested application conditions.

The use of a higher supply voltage (typically 3 to 5 x higher than the nominal voltage) provides a higher torque at higher speed (please refer to graph).

In case that no solution is found, it is possible to adapt the load parameters seen by the motor by the use of a reduction gearhead.

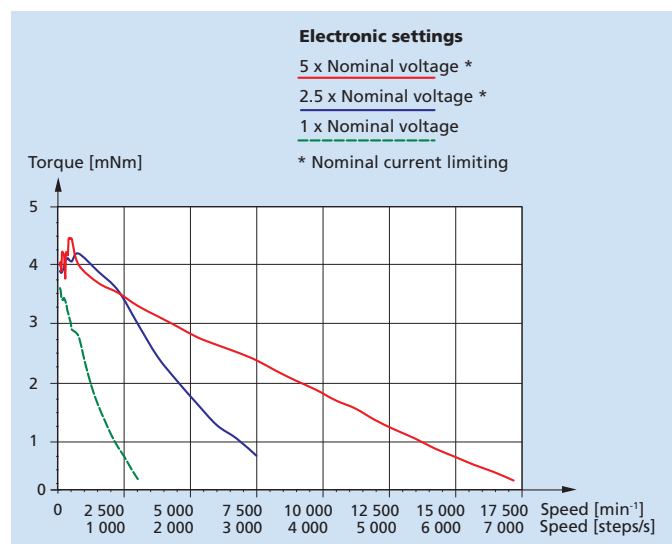

3. Verification of the resolution

It is assumed that the application requires a 9° angular resolution.

The motor selected, the AM1524, has a full step angle of 15° which is not suitable in full step mode. It can be operated either in half-step, which reduces the step angle to 7,5°, or in micro stepping. With micro stepping, the resolution can be increased even higher whereas the precision is reduced because the error angle without load of the motor (expressed in % of a full-step) remains the same independently from the number of micro-steps the motor is operated.

For that reason the most common solution for adapting the motor resolution to the application requirements is the use of a gearhead or a lead-screw where linear motion is required.

4. Operation at low speed

All stepper motors exhibit a resonance frequency. These are typically below 200Hz. When operating at this frequency stepper motors will exhibit uncontrolled perturbations in speed, direction of rotation and a reduced torque. Thus, if the application requires a speed lower or equal to the resonance frequency, it is recommended to drive the motor in microstepping mode where the higher the microstepping rate, the better performance can be achieved. This will greatly decrease the affects of the resonant frequency and result in smoother speed control.

General application notes

In principle each stepper motor can be operated in three modes: full step (one or two phases on), half step or microstep.

Holding torque is the same for each mode as long as dissipated power (I^2R losses) is the same. The theory is best presented on a basic motor model with two phases and one pair of poles where mechanical and electrical angle are equal.

- In full step mode (1 phase on) the phases are successively energised in the following way:
1. A+ 2. B+ 3. A- 4. B-
- Half step mode is obtained by alternating between 1-phase-on and 2-phases-on, resulting in 8 half steps per electrical cycle: 1. A+ 2. A+B+ 3. B+ 4. A-B+ 5. A- 6. A-B- 7. B- 8. A+B-
- If every half step should generate the same holding torque, the current per phase is multiplied by $\sqrt{2}$ each time only 1 phase is energised.

The two major advantages provided by microstep operation are lower running noise and higher resolution, both depending on the number of microsteps per full step which can in fact be any number but is limited by the system cost.

As explained above, one electrical cycle or revolution of the field vector (4 full steps) requires the driver to provide a number of distinct current values proportional to the number of microsteps per full step.

For example, 8 microsteps require 8 different values which in phase A would drop from full current to zero following the cosine function from 0° to 90°, and in phase B would rise from zero to full following the sine function.

These values are stored and called up by the program controlling the chopper driver. The rotor target position is determined by the vector sum of the torques generated in phase A and B:

$$M_A = k \cdot I_A = k \cdot I_o \cdot \cos \varphi$$

$$M_B = k \cdot I_B = k \cdot I_o \cdot \sin \varphi$$

where M is the motor torque, k is the torque constant and I_o the nominal phase current.

For the motor without load the position error is the same in full, half or microstep mode and depends on distortions of the sinusoidal motor torque function due to detent torque, saturation or construction details (hence on the actual rotor position), as well as on the accuracy of the phase current values.

5. Verification in the application

Any layout based on such considerations has to be verified in the final application under real conditions.

Please make sure that all load parameters are taken into account during this test.

Stepper Motors

Two phase

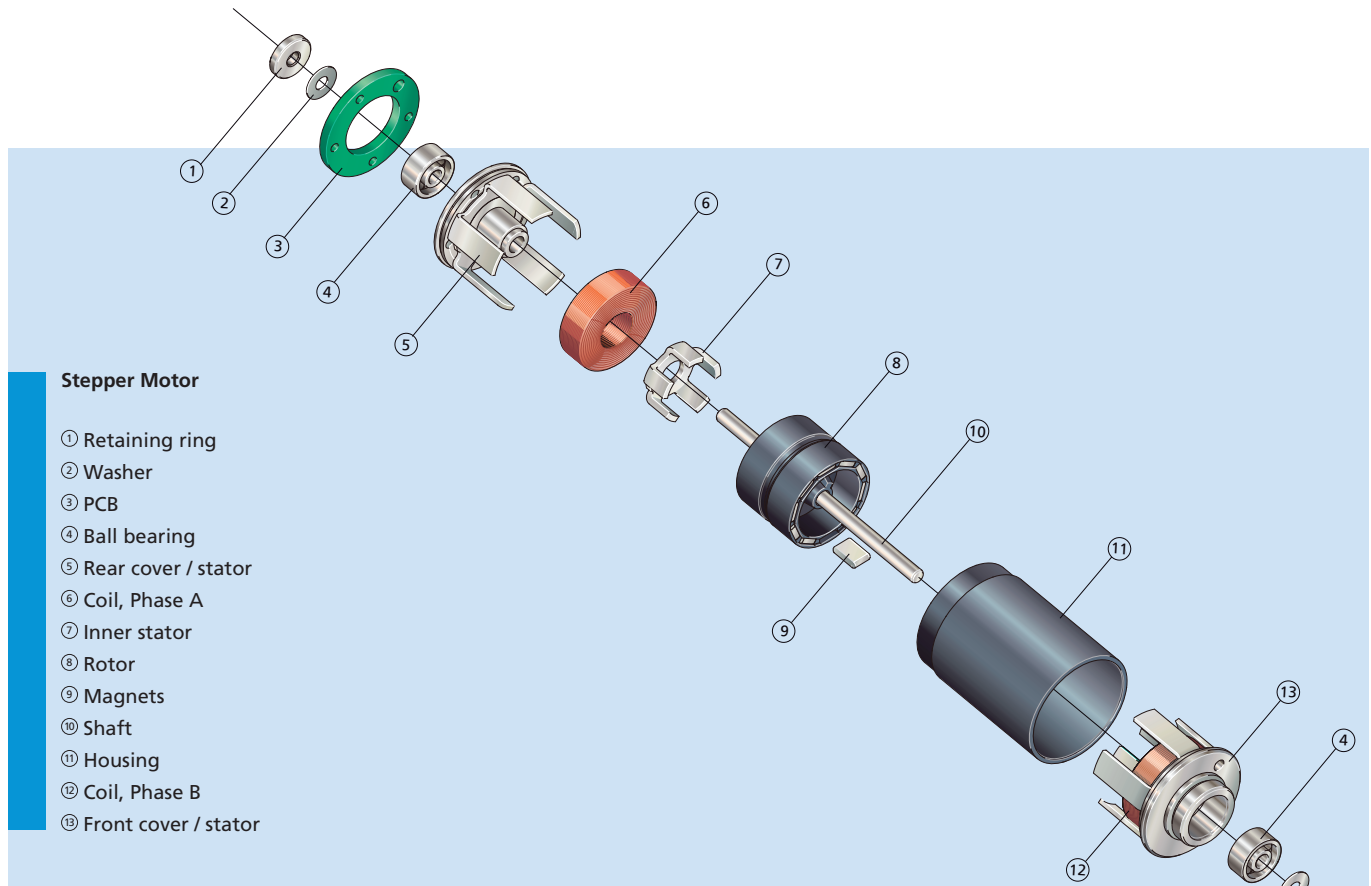

Stepper Motor

- ① Retaining ring
- ② Washer
- ③ PCB
- ④ Ball bearing
- ⑤ Rear cover / stator
- ⑥ Coil, Phase A
- ⑦ Inner stator
- ⑧ Rotor
- ⑨ Magnets
- ⑩ Shaft
- ⑪ Housing
- ⑫ Coil, Phase B
- ⑬ Front cover / stator

Features

PRECiStep® stepper motors are two phase multi-polar motors with permanent magnets. The use of rare-earth magnets provides an exceptionally high power to volume ratio. Precise, open-loop, speed control can be achieved with the application of full step, half step, or micro-stepping electronics.

The rotor consists of an injection moulded plastic support and magnets which are assembled in a 10 or 12 pole configuration depending on the motor type. The large magnet volume helps to achieve a very high torque density. The use of high power rare-earth magnets also enhances the available temperature range of the motors from extremely low temperatures up to 180 °C as a special configuration. The stator consists of two discrete phase coils which are positioned on either side of the rotor. The inner and outer stator assemblies provide the necessary radial magnetic field.

Benefits

- Cost effective positioning drive without an encoder
- High power density
- Long operational lifetimes
- Wide operational temperature range
- Speed range up to 16 000 min⁻¹ using a current mode chopper driver
- Possibility of full step, half step and microstep operation

Product Code



AM1524	Motor series
2R	Bearing type
V-12-150	Coil type
57	Motor version

AM1524-2R-V-12-150-57

Stepper Motors

Two phase with Disc Magnet

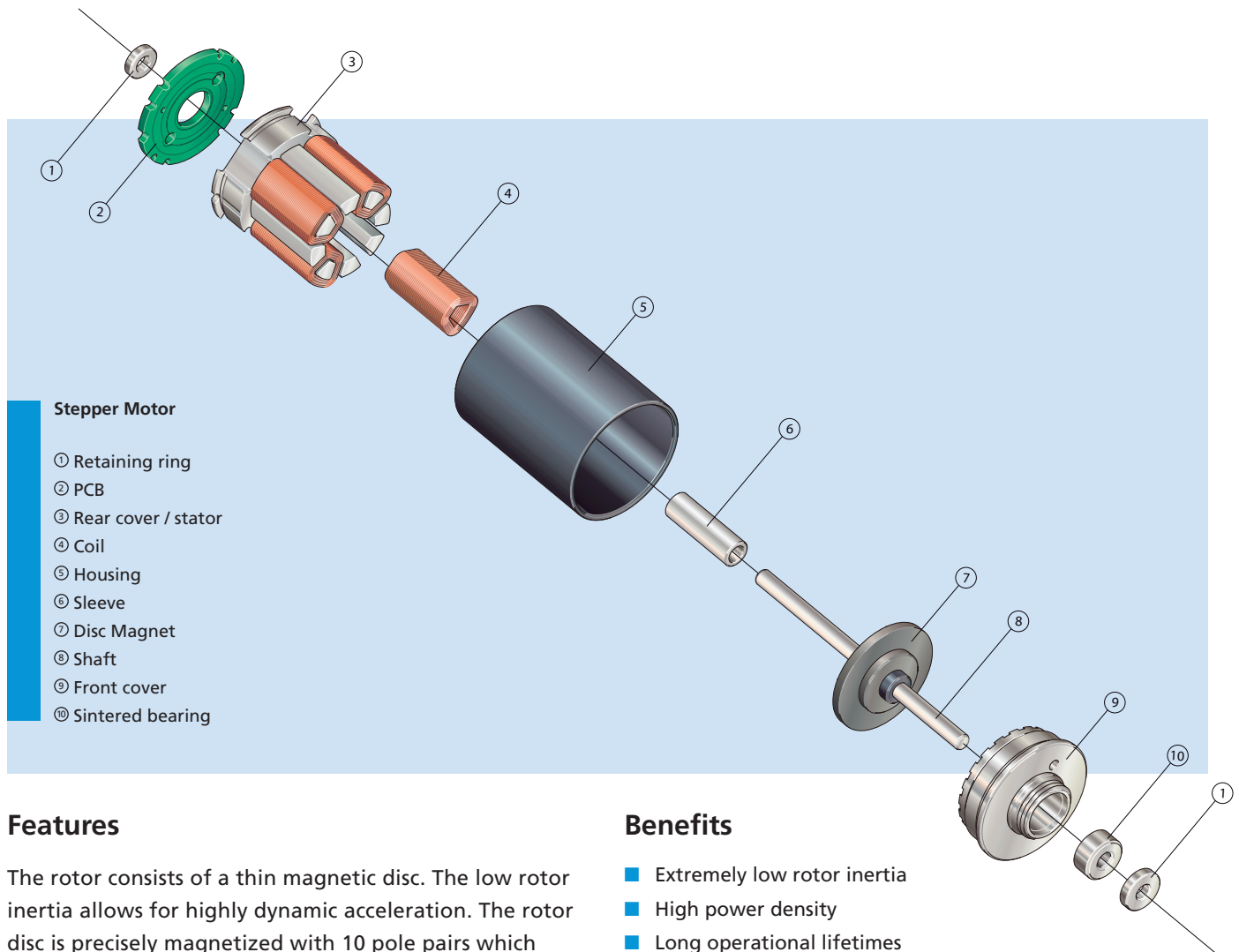

Stepper Motor

- ① Retaining ring
- ② PCB
- ③ Rear cover / stator
- ④ Coil
- ⑤ Housing
- ⑥ Sleeve
- ⑦ Disc Magnet
- ⑧ Shaft
- ⑨ Front cover
- ⑩ Sintered bearing

Features

The rotor consists of a thin magnetic disc. The low rotor inertia allows for highly dynamic acceleration. The rotor disc is precisely magnetized with 10 pole pairs which helps the motor achieve a very high angular accuracy. The stator consists of four coils, two per phase, which are located on one side of the rotor disc and provide the axial magnetic field.

Special executions with additional rotating back-iron are available for exceptionally precise micro-stepping performance.

Benefits

- Extremely low rotor inertia
- High power density
- Long operational lifetimes
- Wide operational temperature range
- Ideally suited for micro-stepping applications

Product Code



ADM1220S	Motor series
2R	Bearing type
V2	Coil type
51	Motor version

ADM1220S-2R-V2-51

Linear DC-Servomotors



Linear DC-Servomotors

Technical Information

Linear DC-Servomotors		
with Analog Hall Sensors QUICKSHAFT® Technology		
Series LM 1247 ... 11		
	LM 1247-	020-11
1 Continuous force ¹⁾	$F_e \text{ max.}$	3,6
2 Peak force ¹⁾²⁾	$F_p \text{ max.}$	10,7
3 Continuous current ¹⁾	$I_e \text{ max.}$	0,55
4 Peak current ¹⁾²⁾	$I_p \text{ max.}$	
5 Back-EMF constant		

Notes on technical data

All values at 22 °C.

Continuous force $F_e \text{ max.}$ [N]

The maximum force delivered by the motor at the thermal limit in continuous duty operation.

$$F_e \text{ max.} = k_F \cdot I_e \text{ max.}$$

Peak force $F_p \text{ max.}$ [N]

The maximum force delivered by the motor at the thermal limit in intermittent duty operation (max. 1 s, 10% duty cycle).

$$F_p \text{ max.} = k_F \cdot I_p \text{ max.}$$

Continuous current $I_e \text{ max.}$ [A]

The maximum motor current consumption at the thermal limit in continuous duty operation.

$$I_e \text{ max.} = \sqrt{\frac{T_{125} - T_{22}}{R \cdot (1 + \alpha_{22} \cdot (T_{125} - T_{22})) \cdot (R_{th1} + 0,45 \cdot R_{th2})}} \cdot \frac{\sqrt{2}}{\sqrt{3}}$$

Peak current $I_p \text{ max.}$ [A]

The maximum motor current consumption at the thermal limit in intermittent duty operation (max. 1 s, 10% duty cycle).

Back-EMF constant k_E [V/m/s]

The constant corresponding to the relationship between the induced voltage in the motor phases and the linear motion speed.

$$k_E = \frac{2 \cdot k_F}{\sqrt{6}}$$

Force constant k_F [N/A]

The constant corresponding to the relationship between the motor force delivered and current consumption.

Terminal resistance, phase-phase R [Ω] $\pm 12\%$

The resistance measured between two motor phases. This value is directly influenced by the coil temperature (temperature coefficient: $\alpha_{22} = 0,004 \text{ K}^{-1}$).

Terminal inductance, phase-phase L [μH]

The inductance measured between two phases at 1 kHz.

Stroke length $s_{\text{max.}}$ [mm]

The maximum stroke length of the moving cylinder rod.

Repeatability [μm]

The maximum measured difference when repeating several times the same movement under the same conditions.

Precision [μm]

The maximum positioning error. This value corresponds to the maximum difference between the set position and the exact measured position of the system.

Acceleration $a_e \text{ max.}$ [m/s^2]

The maximum no-load acceleration from standstill.

$$a_e \text{ max.} = \frac{F_e \text{ max.}}{m_m}$$

Speed $v_e \text{ max.}$ [m/s]

The maximum no-load speed from standstill, considering a triangular speed profile and maximum stroke length.

$$v_e \text{ max.} = \sqrt{a_e \text{ max.} \cdot s_{\text{max.}}}$$

Thermal resistance R_{th1} ; R_{th2} [K/W]

R_{th1} corresponds to the value between coil and housing.

R_{th2} corresponds to the value between housing and ambient air.

The listed values refer to a motor totally surrounded by air. R_{th2} can be reduced with a heat sink and/or forced air cooling.

Thermal time constant τ_{w1} ; τ_{w2} [s]

The thermal time constant of the coil and housing, respectively.

Operating temperature range [°C]

The minimum and maximum permissible operating temperature values of the motors.

Rod weight m_m [g]

The weight of the rod (cylinder with magnets).

Total weight m_t [g]

The total weight of the linear DC-Servomotor.

Linear DC-Servomotors

Technical Information

Magnetic pitch τ_m [mm]

The distance between two equal poles.

Rod bearings

The material and type of bearings.

Housing material

The material of the motor housing.

Direction of movement

The direction of movement is reversible, determined by the control electronics.

Force calculation

To move a mass on a slope, the motor needs to deliver a force to accelerate the load and overcome all forces opposing the movement.

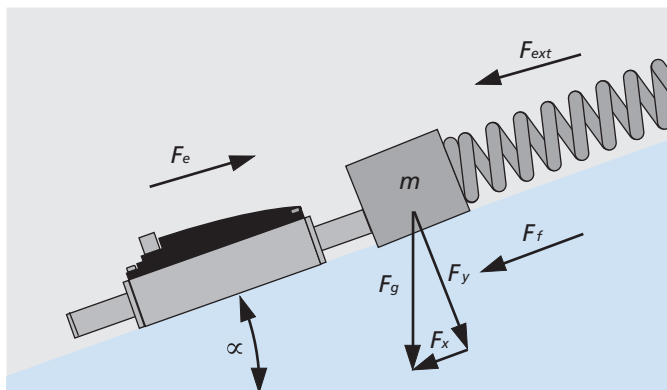

The sum of forces shown in above figure has to be equal to:

$$\sum F = m \cdot a \quad [\text{N}]$$

Entering the various forces in this equation it follows that:

$$F_e - F_{ext} - F_f - F_x = m \cdot a \quad [\text{N}]$$

where:

F_e :	Continuous force delivered by motor	[N]
F_{ext} :	External force	[N]
F_f :	Friction force $F_f = m \cdot g \cdot \mu \cdot \cos(\alpha)$	[N]
F_x :	Parallel force $F_x = m \cdot g \cdot \sin(\alpha)$	[N]
m :	Total mass	[kg]
g :	Gravity acceleration	[m/s ²]
a :	Acceleration	[m/s ²]

Speed profiles

Shifting any load from point A to point B is subject to the laws of kinematics.

Equations of a uniform straight-line movement and uniformly accelerated movement allow definition of the various speed vs. time profiles.

Prior to calculating the continuous duty force delivered by the motor, a speed profile representing the various load movements needs to be defined.

Triangular speed profile

The triangular speed profile simply consists of an acceleration and a deceleration time.

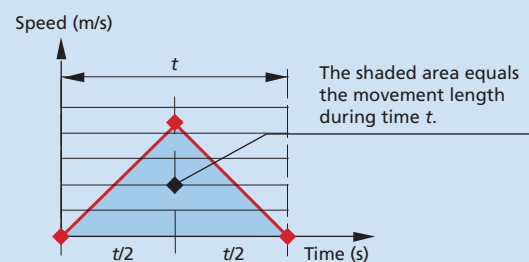

Displacement: $s = \frac{1}{2} \cdot v \cdot t = \frac{1}{4} \cdot a \cdot t^2 = \frac{v^2}{a} \quad [\text{m}]$

Speed: $v = 2 \cdot \frac{s}{t} = \frac{a \cdot t}{2} = \sqrt{a \cdot s} \quad [\text{m/s}]$

Acceleration: $a = 4 \cdot \frac{s}{t^2} = 2 \cdot \frac{v}{t} = \frac{v^2}{s} \quad [\text{m/s}^2]$

Trapezoidal speed profile

The trapezoidal speed profile, acceleration, speed and deceleration, allow simple calculation and represent typical real application cases.

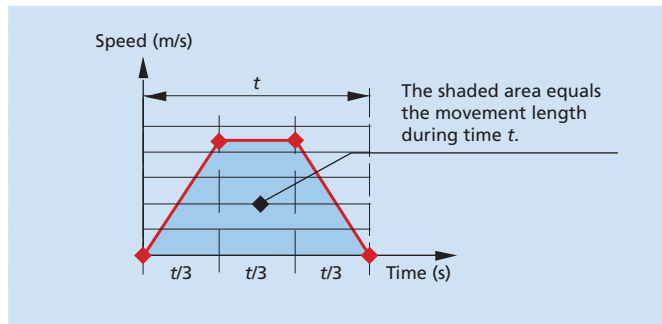

Displacement: $s = \frac{2}{3} \cdot v \cdot t = \frac{1}{4,5} \cdot a \cdot t^2 = 2 \cdot \frac{v^2}{a}$ [m]

Speed: $v = 1,5 \cdot \frac{s}{t} = \frac{a \cdot t}{3} = \sqrt{\frac{a \cdot s}{2}}$ [m/s]

Acceleration: $a = 4,5 \cdot \frac{s}{t^2} = 3 \cdot \frac{v}{t} = 2 \cdot \frac{v^2}{s}$ [m/s²]

How to select a linear DC-Servomotor

This section describes a step-by-step procedure to select a linear DC-Servomotor.

Speed profile definition

To start, it is necessary to define the speed profile of the load movements.

Movement characteristics are the first issues to be considered. Which is the maximum speed? How fast should the mass be accelerated? Which is the length of movement the mass needs to achieve? How long is the rest time?

Should the movement parameters not be clearly defined, it is recommended to use a triangular or trapezoidal profile.

Lets assume a load of 500 g that needs to be moved 20 mm in 100 ms on a slope having a rising angle of 20° considering a trapezoidal speed profile.

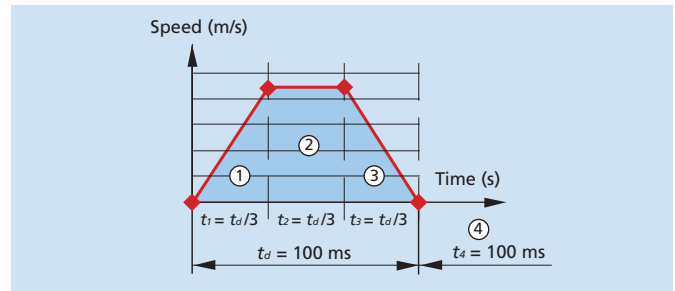

	Unit	①	②	③	④
s (displacement)	m	0,005	0,01	0,005	0
v (speed)	m/s	0 ... 0,3	0,3	0,3 ... 0	0
a (acceleration)	m/s ²	9,0	0	-9,0	0
t (time)	s	0,033	0,033	0,033	0,100

Calculation example

Speed and acceleration of part ①

$$v_{max} = 1,5 \cdot \frac{s}{t} = 1,5 \cdot \frac{20 \cdot 10^{-3}}{100 \cdot 10^{-3}} = 0,3 \text{ m/s}$$

$$a = 4,5 \cdot \frac{s}{t^2} = 4,5 \cdot \frac{20 \cdot 10^{-3}}{(100 \cdot 10^{-3})^2} = 9 \text{ m/s}^2$$

Force definition

Assuming a load of 500 g and a friction coefficient of 0,2, the following forces result:

Force	Unit	Symbol	Forward				Backward			
			①	②	③	④	①	②	③	④
Friction	N	F_f	0,94	0,94	0,94	-0,94	0,94	0,94	0,94	0,94
Parallel	N	F_x	1,71	1,71	1,71	1,71	-1,71	-1,71	-1,71	-1,71
Acceleration	N	F_a	4,5	0	-4,5	0	4,5	0	-4,5	0
Total	N	F_t	7,15	2,65	-1,85	0,77	3,73	-0,77	-5,27	-0,77

Calculation example

Friction and acceleration forces of part ①

$$F_f = m \cdot g \cdot \mu \cdot \cos(\alpha) = 0,5 \cdot 10 \cdot 0,2 \cdot \cos(20^\circ) = 0,94 \text{ N}$$

$$F_a = m \cdot a = 0,5 \cdot 9 = 4,5 \text{ N}$$

Motor selection

Now that the forces of the three parts of the profile are known, requested peak and continuous forces can be calculated in function of the time of each part.

The peak force is the highest one achieved during the motion cycle.

$$F_p = \max(|7,15|, |2,65|, |-1,85|, |0,77|, |3,73|, |-0,77|, |-5,27|, |-0,77|) = 7,15 \text{ N}$$

Linear DC-Servomotors

Technical Information

The continuous force is represented by the expression:

$$F_e = \sqrt{\frac{\sum (t \cdot F_t^2)}{2 \cdot \sum t}} = \dots$$

$$F_e = \sqrt{\frac{0,033 \cdot 7,15^2 + 0,033 \cdot 2,65^2 + 0,033 \cdot (-1,85)^2 + 0,1 \cdot 0,77^2 + 0,033 \cdot 3,73^2 + 0,033 \cdot (-0,77)^2 + 0,033 \cdot (-5,27)^2 + 0,1 \cdot (-0,77)^2}{2 \cdot (0,033 + 0,033 + 0,033 + 0,1)}} = 2,98 \text{ N}$$

With these two values it is now possible to select the suitable motor for the application.

Linearer DC-Servomotor **LM 1247-020-11**

$$s_{max} = 20 \text{ mm}; F_{e \text{ max.}} = 3,6 \text{ N}; F_{p \text{ max.}} = 10,7 \text{ N}$$

Coil winding temperature calculation

To obtain the coil winding temperature, the continuous motor current needs to be calculated.

For this example, considering a force constant k_f equal to 6,43 N/A, gives the result:

$$I_e = \frac{F_e}{k_f} = \frac{2,98}{6,43} = 0,46 \text{ A}$$

With an electrical resistance of 13,17 Ω , a total thermal resistance of 26,2 $^{\circ}\text{C}/\text{W}$ ($R_{th1} + R_{th2}$) and a reduced thermal resistance R_{th2} by 55% ($0,45 \cdot R_{th2}$), the resulting coil temperature is:

$$T_c(I) = \frac{R \cdot (R_{th1} + 0,45 \cdot R_{th2}) \cdot (I_e \cdot \frac{\sqrt{3}}{2})^2 \cdot (1 - \alpha_{22} \cdot T_{22}) + T_{22}}{1 - \alpha_{22} \cdot R \cdot (R_{th1} + 0,45 \cdot R_{th2}) \cdot (I_e \cdot \frac{\sqrt{3}}{2})^2} = \dots$$

$$T_c(I) = \frac{13,17 \cdot (8,1 + 0,45 \cdot 18,1) \cdot (0,46 \cdot \frac{\sqrt{3}}{2})^2 \cdot (1 - 0,0038 \cdot 22) + 22}{1 - 0,0038 \cdot 13,17 \cdot (8,1 + 0,45 \cdot 18,1) \cdot (0,46 \cdot \frac{\sqrt{3}}{2})^2} = 113,5 \text{ }^{\circ}\text{C}$$

Motor characteristic curves

Motion profile:

Trapezoidal ($t1 = t2 = t3$), back and forth

Motor characteristic curves of the linear DC-Servomotor with the following parameters:

Displacement distance: 20 mm

Friction coefficient: 0,2

Slope angle: 20 $^{\circ}$

Rest time: 0,1 s

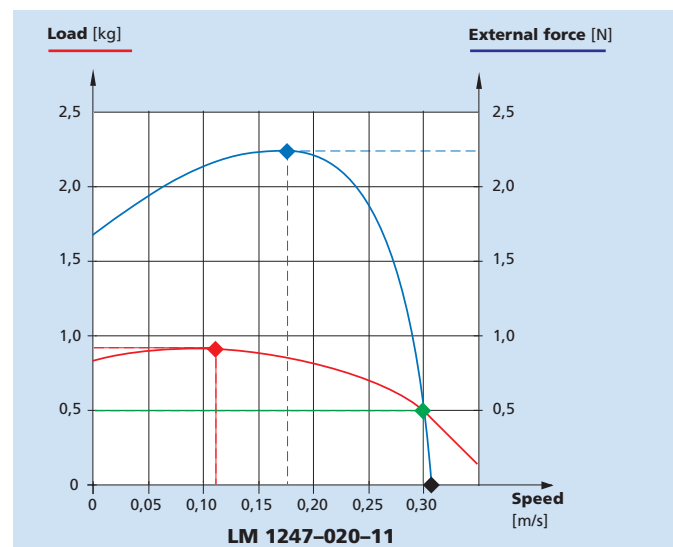

Load curve

Allows knowing the maximum applicable load for a given speed with 0 N external force.

The graph shows that a maximum load (◆) of 0,87 kg can be applied at a speed of 0,11 m/s.

External force curve

Allows knowing the maximum applicable external force for a given speed with a load of 0,5 kg.

The graph shows that the max. achievable speed (◆) without external forces, but with a load of 0,5 kg is 0,31 m/s.

Therefore, the maximum applicable external force (◆) at a speed of 0,3 m/s is 0,5 N.

The external peak force (◆) is achieved at a speed of 0,17 m/s, corresponding to a maximum applicable external force of 2,27 N.

Linear DC-Servomotors

QUICKSHAFT® Technology

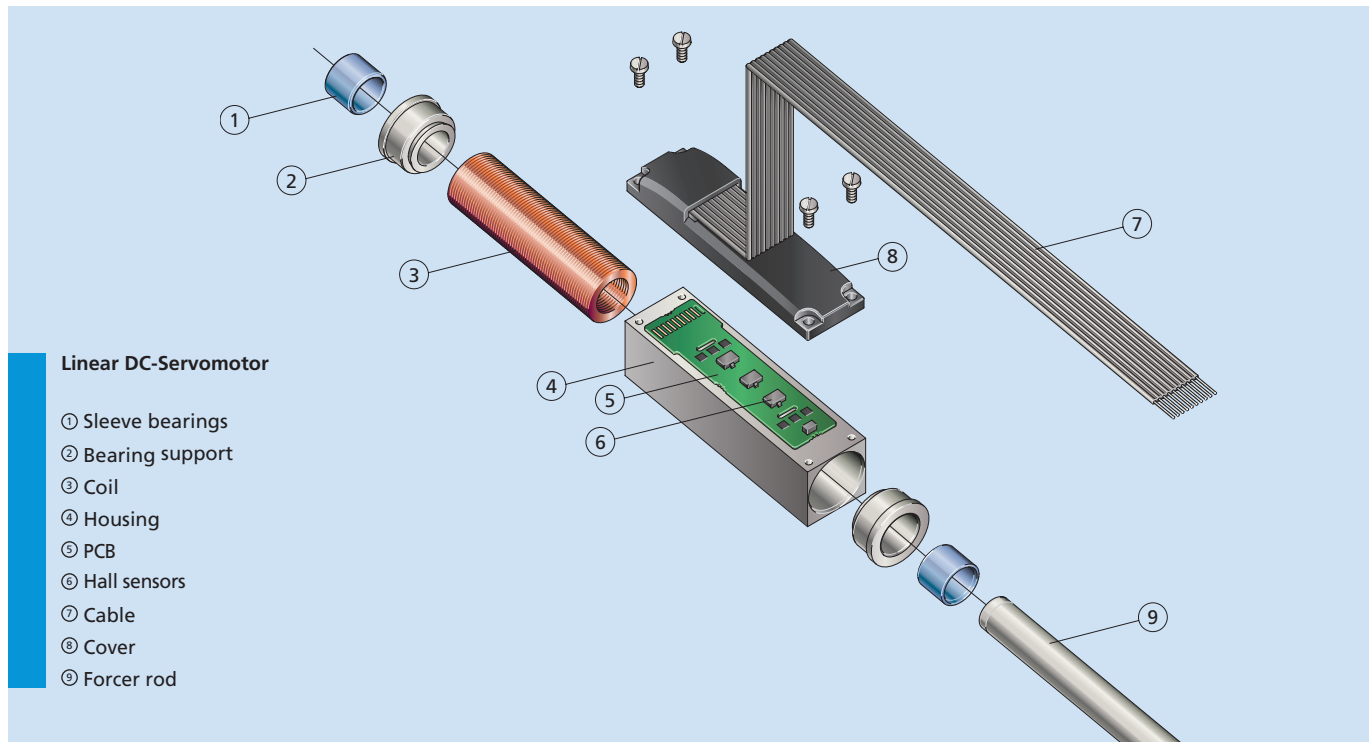

Features

QUICKSHAFT® combines the speed and robustness of a pneumatic system with the flexibility and reliability features of an electro-mechanical linear motor.

The innovative design with a 3-phase self-supporting coil and non-magnetic steel housing offers outstanding performance.

The absence of residual static force and the excellent relationship between the linear force and current make these motors ideal for use in micro-positioning applications. Position control of the QUICKSHAFT® Linear DC-Servomotor is made possible by the built-in Hall sensors.

Performance lifetime of the QUICKSHAFT® Linear DC-Servomotors is mainly influenced by the wear of the sleeve bearings, which depends on operating speed and applied load of the cylinder rod.

Benefits

- High dynamics
- Excellent force to volume ratio
- No residual force present
- Non-magnetic steel housing
- Compact and robust construction
- No lubrication required
- Simple installation and configuration

Product Code



LM	Linear Motor
12	Motor width □ [mm]
47	Motor length [mm]
020	Stroke length [mm]
11	Sensors type: linear

LM1247-020-11

Precision Gearheads



Precision Gearheads

Technical Information

General information

Life performance

The operational lifetime of a reduction gearhead and motor combination is determined by:

- Input speed
- Output torque
- Operating conditions
- Environment and Integration into other systems

Since a multitude of parameters prevail in any application, it is nearly impossible to state the actual lifetime that can be expected from a specific type of gearhead or motor-gearhead combination. A number of options to the standard reduction gearheads are available to increase life performance: ball bearings, all metal gears, reinforced lubrication etc.

Bearings – Lubrication

Gearheads are available with a range of bearings to meet various shaft loading requirements: sintered sleeve bearings, ball bearings and ceramic bearings. Where indicated, ball bearings are preloaded with spring washers of limited force to avoid excessive current consumption.

A higher axial shaft load or shaft pressfit force than specified in the data sheets will neutralise the preload on the ball bearings.

The satellite gears in the 38/1-2 Series Planetary Gearheads are individually supported on sintered sleeve bearings. In the 38A and 44/1 Series, the satellite gears are individually supported on needle or ball bearings.

All bearings are lubricated for life. Relubrication is not necessary and not recommended. The use of non-approved lubricants on or around the gearheads or motors can negatively influence the function and life expectancy.

The standard lubrication of the reduction gears is such as to provide optimum life performance at minimum current consumption at no-load conditions. For extended life performance, all metal gears and heavy duty lubrication are available. Specially lubricated gearheads are available for operation at extended temperature environments and under vacuum.

Notes on technical data

Unspecified tolerances

Tolerances in accordance with ISO 2768 medium.

≤ 6	=	± 0,1 mm
≤ 30	=	± 0,2 mm
≤ 120	=	± 0,3 mm

Input speed

The recommended maximum input speed for continuous operation serves as a guideline. It is possible to operate the gearhead at higher speeds. However, to obtain optimum life performance in applications that require continuous operation and long life, the recommended speed should be considered.

Ball bearings

Ratings on load and lifetime, if not stated, are according to the information from the ball bearing manufacturers.

Operating temperature range

Standard range as listed on the data sheets.

Special executions for extended temperature range available on request.

Reduction ratio

The listed ratios are nominal values only, the exact ratio for each reduction gearhead can be calculated by means of the stage ratio applicable for each type.

Output torque

Continuous operation.

The continuous torque provides the maximum load possible applied to the output shaft; exceeding this value will reduce the service life.

Intermittent operation.

The intermittent torque value may be applied for a short period. It should be for short intervals only and not exceed 5% of the continuous duty cycle.

Direction of rotation, reversible

All gearheads are designed for clockwise and counter-clockwise rotation. The indication refers to the direction of rotation as seen from the shaft end, with the motor running in a clockwise direction.

Backlash

Backlash is defined by the amount by which the width of a tooth space exceeds the width of the engaging tooth on the pitch circle. Backlash is not to be confused with elasticity or torsional stiffness of the system.

The general purpose of backlash is to prevent gears from jamming when making contact on both sides of their teeth simultaneously. A small amount of backlash is desirable to provide for lubricant space and differential expansion between gear components. The backlash is measured on the output shaft, at the last geartrain stage.

Precision Gearheads

Technical Information

Zero Backlash Gearheads

The spur gearheads, series 08/3, 12/5, 15/8, 16/8 and 22/5, with dual pass geartrains feature zero backlash when pre-loaded with a FAULHABER DC-Micromotor.

Preloaded gearheads result in a slight reduction in overall efficiency and load capability.

Due to manufacturing tolerances, the preloaded gearheads could present higher and irregular internal friction torque resulting in higher and variable current consumption in the motor.

However, the unusual design of the FAULHABER zero backlash gearheads offers, with some compromise, an excellent and unique product for many low torque, high precision positioning applications.

The preloading, especially with a small reduction ratios, is very sensitive. This operation is achieved after a defined burn-in in both directions of rotation. For this reason, gearheads with pre-loaded zero backlash are only available when factory assembled to the motor.

The true zero backlash properties are maintained with new gearheads only. Depending on the application, a slight backlash could appear with usage when the gears start wearing. If the wearing is not excessive, a new preload could be considered to return to the original zero backlash properties.

Assembly instructions

It is strongly recommended to have the motors and gearheads factory assembled and tested. This will assure perfect matching and lowest current consumption.

The assembly of spur and hybrid gearheads with motors requires running the motor at very low speed to ensure the correct engagement of the gears without damage.

The planetary gearheads must not be assembled with the motor running. The motor pinion must be matched with the planetary input-stage gears to avoid misalignment before the motor is secured to the gearhead.

When face mounting any gearhead, care must be taken not to exceed the specified screw depth. Driving screws beyond this point will damage the gearhead. Gearheads with metal housing can be mounted using a radial set screw.

How to select a reduction gearhead

This section gives an example of a step-by-step procedure on how to select a reduction gearhead.

Application data

The basic data required for any given application are:

Required torque	M	[mNm]
Required speed	n	[min ⁻¹]
Duty cycle	δ	[%]
Available space, max.	diameter/length	[mm]
Shaft load	radial/axial	[N]

The assumed application data for the selected example are:

Output torque	M	=	120 mNm
Speed	n	=	30 min ⁻¹
Duty cycle	δ	=	100%
Space dimensions, max.	diameter	=	18 mm
	length	=	60 mm
Shaft load	radial	=	20 N
	axial	=	4 N

To simplify the calculation in this example, the duty cycle is assumed to be continuous operation.

Preselection

A reduction gearhead which has a continuous output torque larger than the one required in the application is selected from the catalogue.

If the required torque load is for intermittent use, the selection is based on the output torque for intermittent operation.

The shaft load, frame size and overall length with the motor must also meet the minimum requirements.

The product selected for this application is the planetary gearhead, type 16/7.

Output torque, continuous operation	$M_{max.}$	=	300 mNm
Recommended max. input speed for			
- Continuous operation	n	≤	5 000 min ⁻¹
- Shaft load, max.	radial	≤	30 N
	axial	≤	5 N

Calculation of the reduction ratio

To calculate the theoretical reduction ratio, the recommended input speed for continuous operation is divided by the required output speed.

$$i_N = \frac{\text{Recommended max. input speed}}{\text{required output speed}}$$

From the gearhead data sheet, a reduction ratio is selected which is equal to or less than the calculated one.

For this example, the reduction ratio selected is 159 : 1.

Calculation of the input speed n_{input}

$$n_{input} = n \cdot i \quad [\text{min}^{-1}]$$

$$n_{input} = 30 \cdot 159 = 4\,770 \quad \text{min}^{-1}$$

Calculation of the input torque M_{input}

$$M_{input} = \frac{M \cdot 100}{i \cdot \eta} \quad [\text{mNm}]$$

The efficiency of this gearhead is 60%, consequently:

$$M_{input} = \frac{120 \cdot 100}{159 \cdot 60} = 1,26 \quad \text{mNm}$$

The values of

Input speed	n_{input}	= 4 770	min ⁻¹
and			

Input torque	M_{input}	= 1,26	mNm
--------------	-------------	--------	-----

are related to the motor calculation.

The motor suitable for the gearhead selected must be capable of producing at least two times the input torque needed.

For this example, the DC-Micromotor type 1624 E 024 S supplied with 14 VDC will produce the required speed and torque.

For practical applications, the calculation of the ideal motor-gearhead drive is not always possible.

Detailed values on torque and speed are usually not clearly defined.

It is recommended to select suitable components based on a first estimation, and then test the units in the application by varying the supply voltage until the required speed and torque are obtained.

Recording the applied voltage and current at the point of operation, along with the type numbers of the test assembly, we can help you to select the ideal motor-gearhead.

The success of your product will depend on the best possible selection being made!

For confirmation of your selection and peace of mind, please contact our sales engineers.

Precision Gearheads

Planetary Gearheads

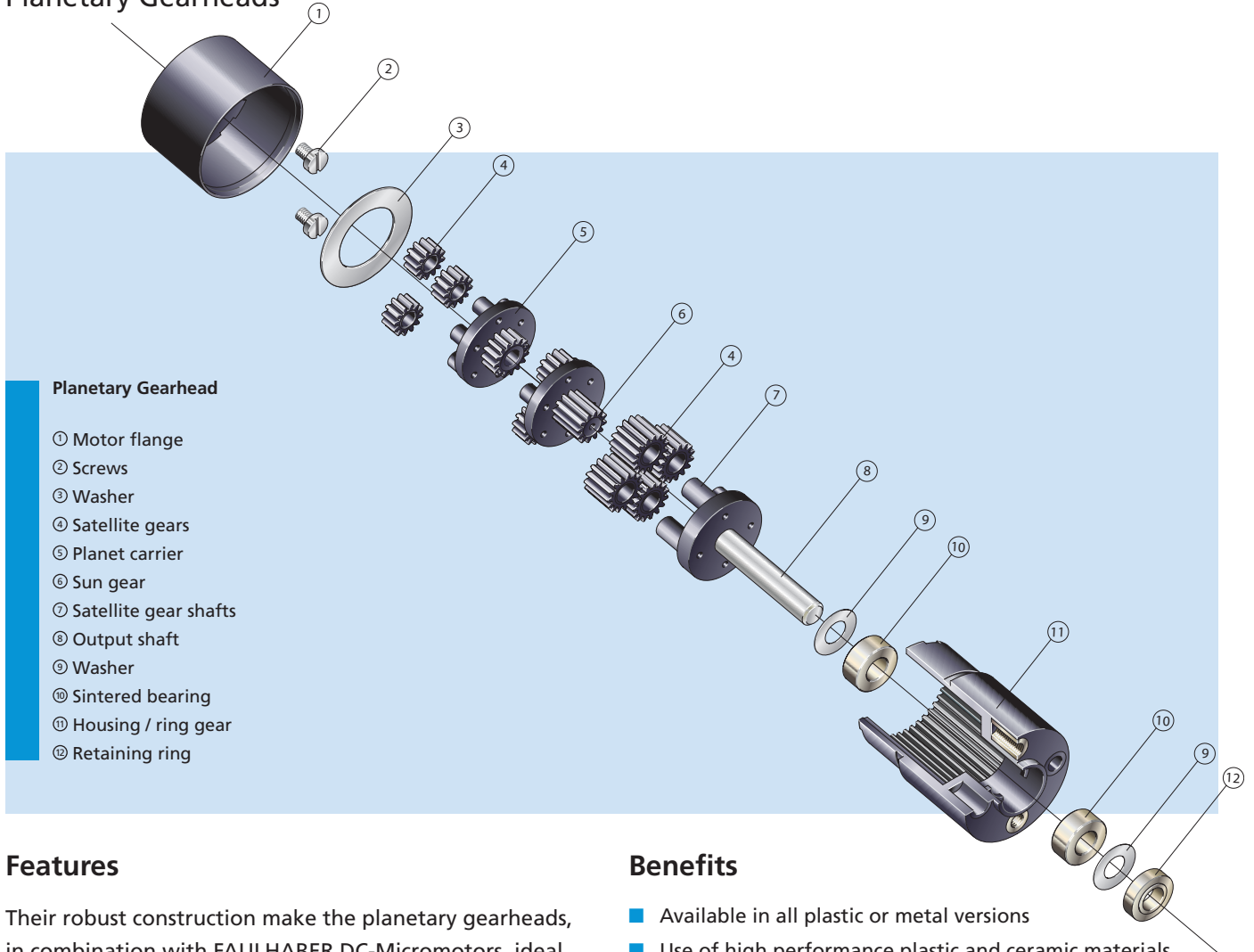

Planetary Gearhead

- ① Motor flange
- ② Screws
- ③ Washer
- ④ Satellite gears
- ⑤ Planet carrier
- ⑥ Sun gear
- ⑦ Satellite gear shafts
- ⑧ Output shaft
- ⑨ Washer
- ⑩ Sintered bearing
- ⑪ Housing / ring gear
- ⑫ Retaining ring

Features

Their robust construction make the planetary gearheads, in combination with FAULHABER DC-Micromotors, ideal for high torque, high performance applications. In most cases, the geartrain of the input stage is made of plastic to keep noise levels as low as possible at higher speed. All steel input gears as well as a modified lubrication are available for applications requiring very high torque, vacuum, or higher temperature compatability.

For applications requiring medium to high torque FAULHABER offers planetary gearheads constructed of high performance plastics. They are ideal solutions for applications where low weight and high torque density play a decisive role. The gearhead is mounted to the motor with a threaded flange to ensure a solid fit.

Benefits

- Available in all plastic or metal versions
- Use of high performance plastic and ceramic materials
- Available with a variety of shaft bearings including sintered, ceramic, and ball bearings
- Modified versions for extended temperature and special environmental conditions are available
- Custom modifications available

Product Code



All metal planetary gearhead series 12/4

26	Outer diameter [mm]
A	Version
64:1	Reduction ratio

26A 64:1

Precision Gearheads

Spur Gearheads

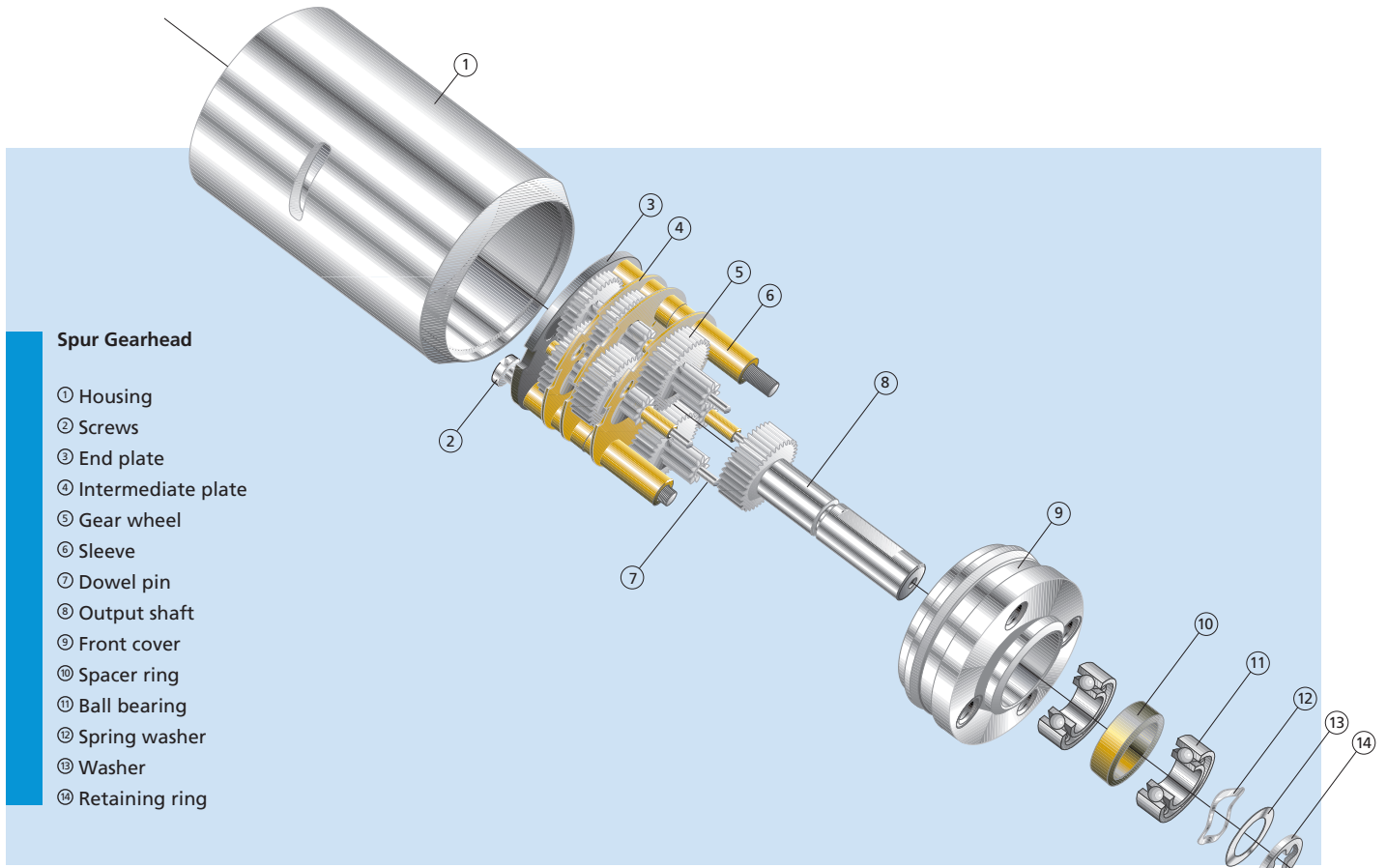

Spur Gearhead

- ① Housing
- ② Screws
- ③ End plate
- ④ Intermediate plate
- ⑤ Gear wheel
- ⑥ Sleeve
- ⑦ Dowel pin
- ⑧ Output shaft
- ⑨ Front cover
- ⑩ Spacer ring
- ⑪ Ball bearing
- ⑫ Spring washer
- ⑬ Washer
- ⑭ Retaining ring

Features

A wide range of high quality spur gearheads are available to compliment FAULHABER DC-Micromotors. The all metal or plastic input-stage geartrain assures extremely quiet running. The precise construction of the gearhead causes very low current consumption in the motor, giving greater efficiency. The gearhead is sleeve mounted on the motor, providing a seamless in-line fit. The FAULHABER Spur Gearheads are ideal for high precision, low torque and low noise applications.

gear passes to each other and locking them in place on the motor pinion gear. They are ideal for positioning applications with a very high resolution and moderate torque. Zero backlash gearheads can only be delivered preloaded from the factory.

Benefits

- Available in a wide variety of reduction ratios including very high ratios
- Zero backlash versions are available
- Available with a variety of shaft bearings including sintered, ceramic, and ball bearings

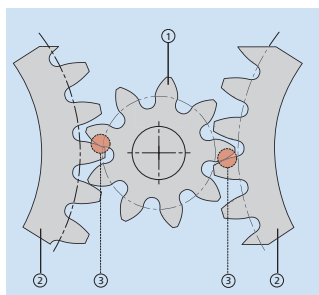

Zero Backlash Spur Gearhead

- ① Motor pinion
- ② Dual-pass geartrain input stage
- ③ Zero backlash preloaded engagement

FAULHABER offers a special version of a spur gearhead with zero backlash. These gearheads consist of a dual pass spur geartrain with all metal gears. The backlash is reduced to a minimum by counter-rotating the two individual

Product Code



22	Outer diameter [mm]
/5	Version
377:1	Reduction ratio

22/5 377:1

Linear Components



Ball Screw

Technical information

General information

Function:

Ball screws convert rotational movements into an axial movement. Ball screws, which are designed as a recirculating ball screw, have a very high level of efficiency in comparison with planetary screw drives (such as trapezoidal screws or metric screws) due to the lower rolling friction that occurs. In addition, the superior manufacturing precision enables a very low axial play, accompanied by a very high positioning accuracy.

In addition to the ball screw, the BS product series also includes both the bearing and the coupling to the motor. The duplex bearing used in this case – a pair of angular ball bearings with backlash-free mounting – enables the absorption of axial tensile and compressive forces. The high-precision pin coupling transmits the motor torque to the screw virtually backlash-free.

Mounting

A number of threaded holes are provided on the front of the housing for the purpose of attaching the motor-screw combination.

Because of the high-precision raceways and the low-backlash or backlash-free adjustment, the ball screw nut cannot compensate for radial deviations between screw axis and any additional guides of an attachment to the nut. A radial decoupling element must be provided here if necessary. This relates to deviations of the radial distance (misalignment) and angular deviations (tipping) of the guides.

In order to reduce radial forces on the bearing, it is recommended that the screw is supported by an additional bearing.

Handling

The ball raceways on the ball screws are exposed. For this reason, the screw drives have to be protected against dirt and contamination. The ball screw nut must never, either in operation or during mounting, be moved out beyond the raceway area of the ball screw.

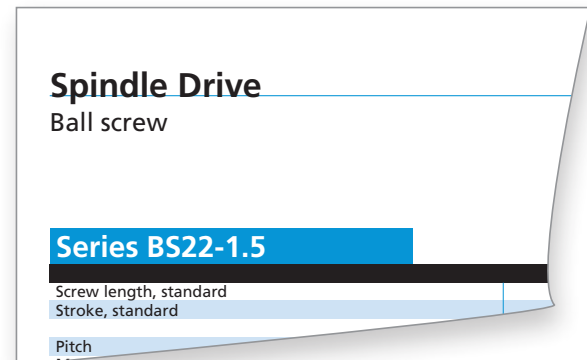

Explanations regarding the data sheets

Ball screw length, standard [mm]

Designates the length of the ball screw between the front of the housing and the end of the ball screw.

Stroke [mm]

Maximum path which the ball screw nut may axially travel. The metric fastening thread of the ball screw nut can protrude beyond the raceway area of the ball screw.

Pitch P_h [mm]

Axial displacement when rotating the ball screw by 360° relative to the ball screw nut.

Average actual travel deviation, max. permissible e_p [μm]

The averaged deviation of the actual travel from the ideal nominal travel is called the average actual travel deviation e_{0a} . This is limited by the value e_p over the entire travel ($e_{0a} \leq e_p$).

Tolerance of travel variation v_{up} [μm]

In parallel with the average actual travel deviation, short-wave travel variations can occur. The bandwidth, represented as a blue band in the following, is limited by the value of the tolerance of travel variation v_{up} .

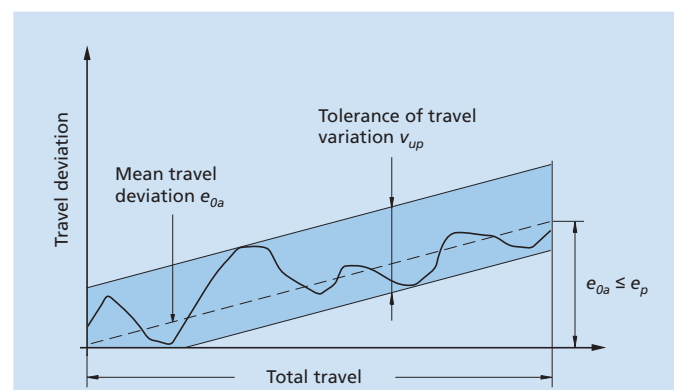

Ball Screw

Technical information

Efficiency η_{max} [%]

Describes the ratio between the power input and power output of the ball screw at axial load $F_{m\ max}$.

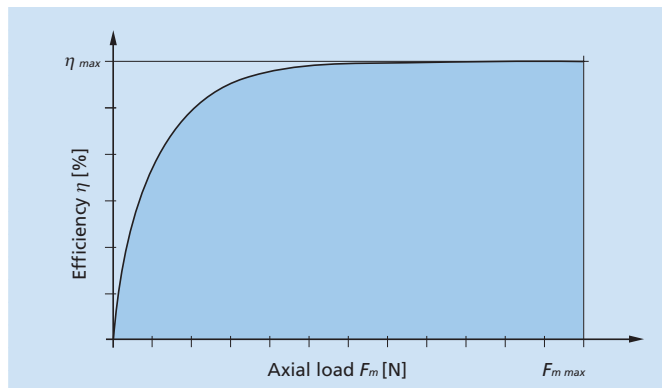

Please observe the dependence of the efficiency on the axial load, especially for small axial loads.

Operating temperature range [C°]

Designates the maximum and minimum permissible operating temperature of the ball screw.

Axial load capacity, dynamic C_{am} [N]

Parameter for calculating the theoretical service life. This corresponds to a constant axial load in a constant direction, at which a theoretical service life of 10^6 revolutions is achieved. This is based on a life expectancy of 90%.

Axial load capacity, static C_{oa} [N]

Maximum permissible axial loading of the ball screw nut. Unless specified otherwise, this is also the maximum permissible axial loading of the ball screw. To prevent exceeding of the permissible loading, the motor current must be limited if necessary.

Max. permissible shaft loading, radial $F_{rs\ max}$ [N]

Maximum permissible radial loading of the ball screw. This is dependent on the acting lever arm.

Screw nut, axial play [μ m]

Maximum axial displacement of the ball screw nut in relation to the ball screw, if these are not twisted towards each other. This is determined using an axial test force of 3.5 N.

Max. permissible nut loading, radial $F_{rn\ max}$ [N]

Maximum permissible radial loading of the ball screw nut.

Direction of rotation

Direction of rotation of the ball screw, observed from the direction of the ball screw. With a right-hand thread the clockwise direction of rotation of the drive shaft (= rotating clockwise) results in an increase in the distance between drive and ball screw nut.

Recommended values

The maximum permissible values for continuous operation in order to obtain an optimal service life are listed below. The values are mathematically independent of each other.

Continuous axial load $F_{m\ max}$ [N]

Designates the maximum recommended axial load during continuous operation.

Intermittent axial load $F_{p\ max}$ [N]

Designates the maximum permissible axial load. The motor current must be limited if necessary in order to prevent exceeding of the permissible loading.

Rotational speed, max. [min^{-1}]

Designates the maximum permissible rotational speed.

Linear speed, max. [mm/s]

Designates the maximum permissible linear speed. This results from the product of the maximum permissible rotational speed and the pitch P_h .

Calculations

Calculation of the motor drive torque

The minimum required motor drive torque can be derived as follows

$$M_{mot} = \frac{F_m \cdot P_h \cdot 100}{2\pi \cdot \eta}$$

Required motor torque	M_{mot}	[mNm]
Continuous axial load	F_m	[N]
Pitch	P_h	[mm]
Efficiency	η	[%]

Calculation of the motor drive speed

$$n_{mot} = \frac{v \cdot 60}{P_h}$$

Required motor speed	n_{mot}	[min ⁻¹]
Linear speed	v	[mm/s]
Pitch	P_h	[mm]

Calculation of the theoretical lifetime

The service life depends on the following factors:

- Axial load
- Linear speed
- Operating conditions
- Environment and installation in other systems

As a very large number of parameters come into play in any application, a precise service life definition is not possible.

As a non-binding reference value a theoretical service life can be calculated on the basis of standard ISO 3408:

The theoretical service life is generally defined by the number of revolutions. Alternatively, it can also be specified in hours or as travel. It is based on a life expectancy of 90%.

The theoretical service life is calculated as follows:

$$L_{rev} = \left(\frac{C_{am}}{F_m} \right)^3 \cdot 10^6$$

$$L_h = \frac{L_{rev}}{n_m \cdot 60}$$

$$L_s = P_h \cdot \left(\frac{C_{am}}{F_m} \right)^3 \cdot 10^3$$

Service life in revolutions	L_{rev}	[rev]
Service life in hours	L_h	[h]
Service life in meters	L_s	[m]
Dynamic axial load capacity	C_{am}	[N]
Continuous axial load	F_m	[N]
Average motor speed	n_m	[min ⁻¹]
Pitch	P_h	[mm]

Ball Screw

Technical information

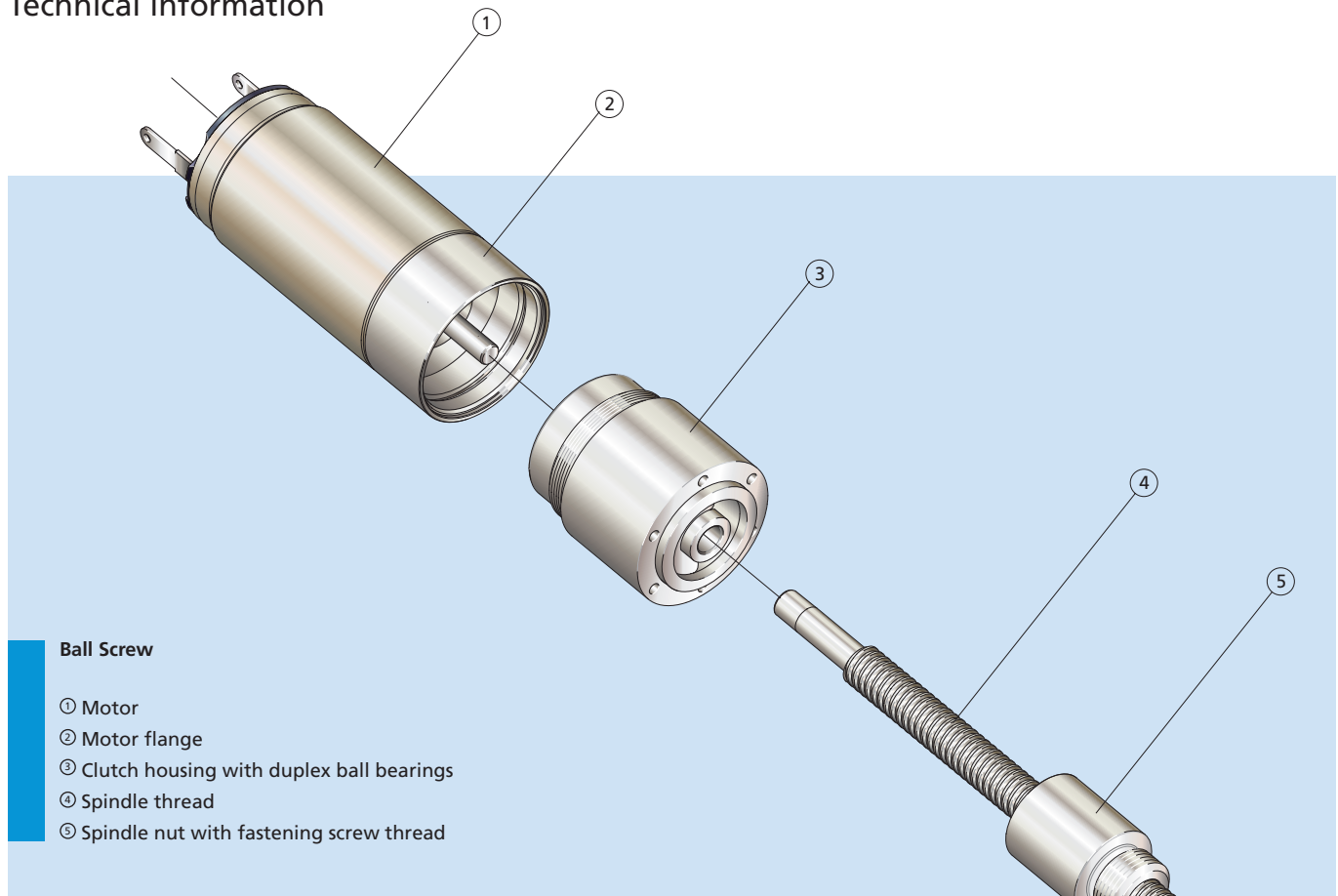

Ball Screw

- ① Motor
- ② Motor flange
- ③ Clutch housing with duplex ball bearings
- ④ Spindle thread
- ⑤ Spindle nut with fastening screw thread

Features

Thanks to their high-precision mechanical design, FAULHABER ball screws are ideally suited for positioning tasks requiring a high degree of accuracy. Combinations with DC-Micromotors with high-resolution encoders, integrated Motion Controllers or Stepper Motors represent a superior system solution for the most demanding applications in optical systems, special machine construction, automation or medical technology.

Compact design in conjunction with numerous modification options translates into the perfect drive solution for a wide range of applications.

Benefits

- Long service life
- High efficiency
- Variable length
- Customized versions with special lubrication for extended application areas
- High positioning accuracy thanks to considerably reduced play

Product Code



BS	Ball screw
22	Coupling diameter [mm]
1.5	Pitch [mm]

BS 22-1.5

Lead Screws and Options

Technical Information

Lead Screws Parameters

Resolution (travel/step)

A lead screw combined with a PRECIstep® stepper motor can achieve a positioning with a resolution of 10µm.

The resolution of the position depends on the pitch and number of steps per revolution:

$$P = \frac{P_h}{n}$$

With P_h the pitch of the screw and n the number of steps per revolution of the motor.

Driving the motor with half-stepping or microstepping will improve the resolution up to a certain extent.

The resolution must be balanced with another parameter: the precision.

Precision

The motor step angle accuracy is one parameter, together with the axial play between the nut and the lead screw, influencing the precision of the linear displacement. It varies between ± 3 and $\pm 10\%$ of a full step angle depending on the motor model (see line 9 on motor datasheet) and remains the same with microstepping. It is however not cumulative.

Axial play

An axial play up to 30µm is measured with optional nuts offered in this catalogue. However, it is possible to negate the axial play by implementing a preloading system in the design of the application (for instance with a spring mechanism).

The "zero" axial play between the lead screw and motor housing is ensured thanks to a preload of the motor ball bearings (in standard configuration: spring washer on rear ball bearing). An axial play up to 0.2 mm will occur if the axial load on the lead screw exceeds the ball bearing preload.

This does not cause any damage to the motor and is reversible. This occurs only while pulling on the shaft. On request, customization can overcome this limitation.

Lead Screw

Linear actuation for positioning tasks
PRECIstep® Technology

Series M2 x 0,2 x L1

Nominal diameter	2,0
Pitch	0,2
Material	

Backdriving

Backdriving the motors while applying an axial load on the lead screws is impossible. The pitch vs. diameter ratio does not allow it.

Force vs speed curves

The force that a linear system can provide depends on the type of screw and stepper motor selected. Torque vs speed curves for each solution are provided in this catalogue. Those curves do already consider a 40% safety factor on the motor torque as well as the lead screw efficiency in the calculation.

Tip for bearings

Ideally, the application should handle radial loads and the lead screw only axial loads. If it is not the case, it is possible to get lead screws with a tip suitable for bearing at its front end in order to handle radial loads. With this configuration, a special care to the alignment of the motor and bearing must be paid to not deteriorate the thrust force achievable. Optional mating ball bearings are available in the dedicated datasheet for options.

Nut

Optional nuts offered in this catalogue are shaped with a flat in order to prevent its rotations in the application. Alternatively, tapped holes on the application are a convenient solution since metric taps are readily available.

Lead Screws and Options

Technical Information

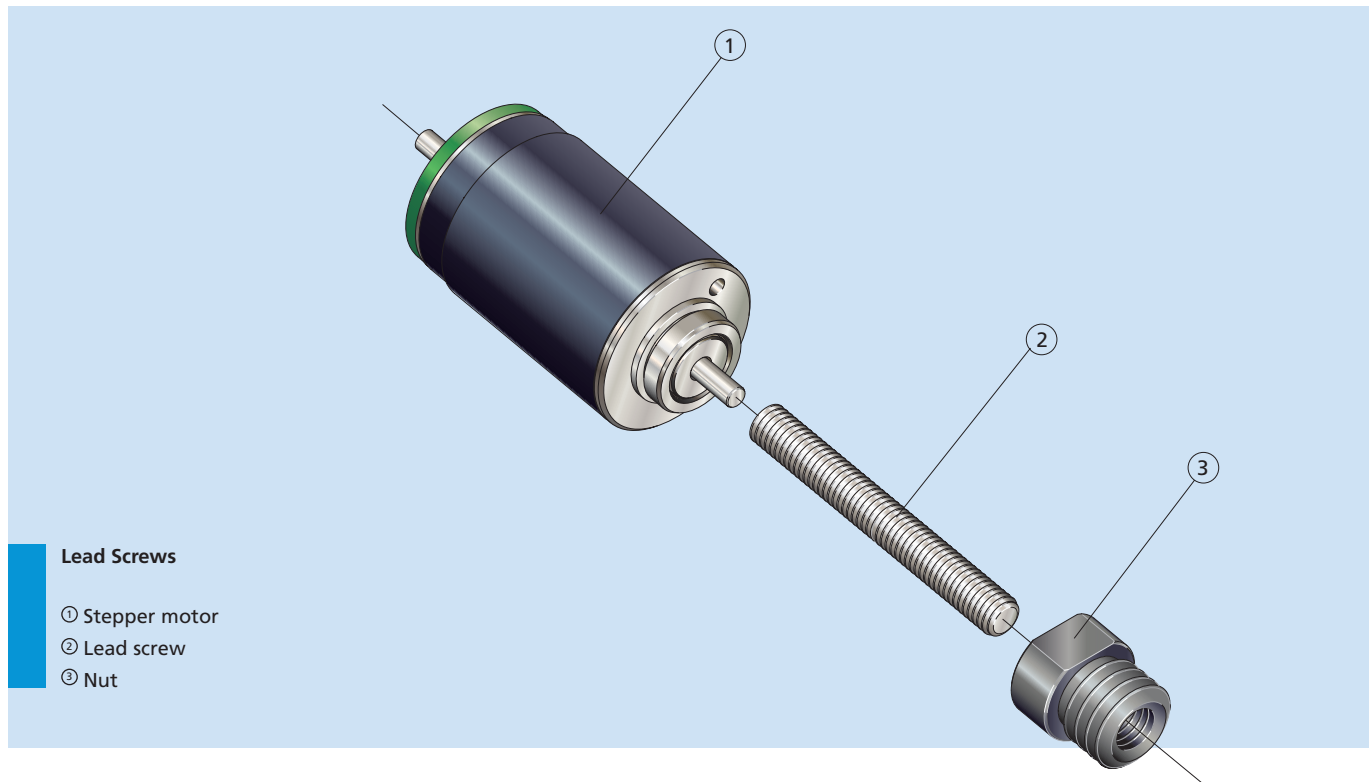

Lead Screws

- ① Stepper motor
- ② Lead screw
- ③ Nut

Features

Stepper motors can be used for more than just a rotation. When combined with lead screws, they provide a high accuracy linear positioning system that provides the benefits of a stepper (open loop control, long life, high torque density, etc.).

The lead screws available on stepper motors are all based on metric dimensions (M1.2 up to M3) and specifically designed to be assembled with PRECistep® stepper motors. The technique used to produce the thread ensures a very high precision and consistency of quality. A large choice of standard lengths is available from stock and customization is possible on request.

Such a combination is ideal for any application such as requiring accurate linear movement or lens adjustment (zoom, focus), microscope stages or medical syringes.

Benefits

- Cost effective positioning drive without encoder
- High accuracy
- Wide range of lead screws available
- Short lead time for standard length
- Flexibility offered by optional nuts and ball bearings
- Custom length on request

Product Code



AM1524-2R-V-12-150-55

M3 x 0,5 x 15

AM1524	Motor series	M3	Screw type
2R	Bearing type	0.5	Pitch (mm)
V-12-150	Winding type	15	Length (mm)
55	Motor version		

Encoders



Encoders

Technical Information

Encoders
magnetic Encoder, digital outputs,
2 channels, 16 - 4096 lines per revolution

Series IEH2-4096

	IEH2	- 16
Lines per revolution	<i>N</i>	16
Frequency range, up to ¹⁾	<i>f</i>	5
Signal output, square wave		2
Supply voltage	<i>U_{DD}</i>	4.5
Current consumption, typical ²⁾		
Output current, max. ³⁾		

Notes on technical data

Lines per revolution (*N*)

The number of incremental encoder pulses per revolution per channel.

The output signal is a quadrature signal which means that both the leading and following edge, or flank, can be evaluated. For example, an encoder with two channels and 256 lines per revolution has 1024 edges, or flanks per revolution.

Output signal

The number of output channels. For example, the IE3 encoders offer 2 channels, *A* and *B*, plus 1 additional index channel.

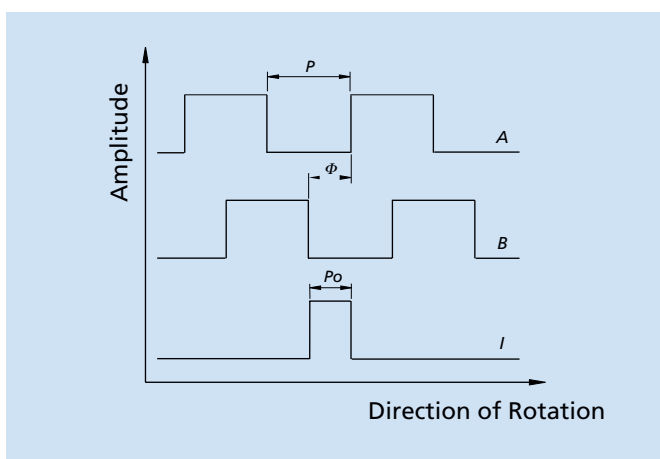

Supply Voltage (*U_{DD}*)

Defines the range of supply voltage necessary for the encoder to function properly.

Current consumption, typical (*I_{DD}*)

Indicates the typical current consumption of the encoder at the given supply voltage.

Output current, max. (*I_{OUT}*)

Indicates the maximum allowable load current at the signal outputs.

Puls width (*P*)

Width of the output signal in electrical degrees (°e) of the channels *A* and *B*. The value corresponds to one full period, or 360 °e at channel *A* or *B*.

Index pulse width (*P₀*)

Indicates the width of the index pulse signal in electrical degrees.

Tolerance ΔP_0 :

$$\Delta P_0 = \left| 90^\circ - \frac{P_0}{P} * 180^\circ \right|$$

Phase shift, channel *A* to *B* (Φ)

The phase shift in electrical degrees between the following edge of output channel *A* and the leading edge of output channel *B*.

Phase shift tolerance ($\Delta\Phi$)

Indicates the allowable position error, in electrical degrees, between the following edge of channel *A* to the leading edge of channel *B*.

$$\Delta\Phi = \left| 90^\circ - \frac{\Phi}{P} * 180^\circ \right|$$

Signal period (*C*)

The total period, measured in electrical degrees of one pulse on channel *A* or *B*.

Typically one period is 360 °e.

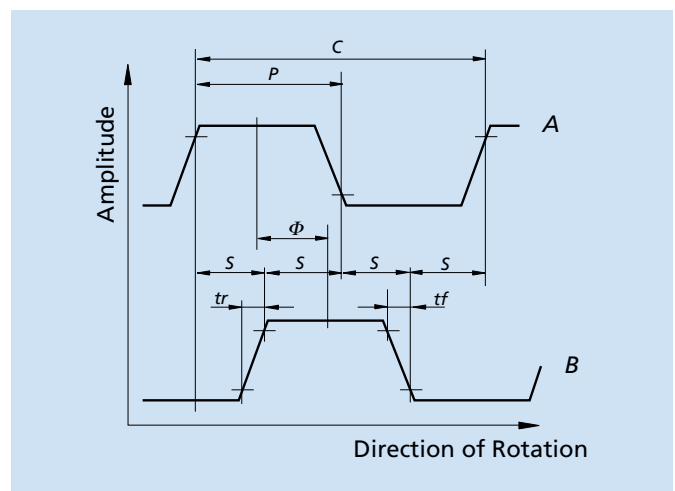

Logic state width (S)

The distance measured in electrical degrees (°e) between two neighbouring signal edges, for example the leading edge of signal *A* to the leading edge of signal *B*.

Typically this has a value of 90 °e.

Signal rise/fall time, typical (tr/tf)

Corresponds to the slope of the rising and falling signal edges.

Frequency range (f)

Indicates the maximum encoder frequency. The maximum achievable motor speed can be derived using the following formula.

$$n = \frac{60 \cdot f}{N}$$

Inertia of the code disc (J)

Indicates the additional inertial load due on the motor due to the code wheel.

Operating temperature range

Indicates the minimum and maximum allowable temperature range for encoder operation.

Test speed

The speed at which the encoder specifications were measured.

Line Driver

This is an integrated signal amplifier in the encoder that makes it possible to send the encoder signals through much longer connection cables. It is a differential signal with complementary signals to all channels which eliminates sensitivity to ambient electrical noise.

Synchronous serial interface

The synchronous serial interface (SSI) is an interface for absolute encoders with which absolute position information is supplied via serial data transfer. Position value transfer is synchronized with a clock rate defined by a control.

Steps per revolution

Steps per revolution indicates the number of position values per motor revolution.

Set-up time after power on

Maximum time to availability of the output signals, as of when supply voltage is applied.

Clock frequency max.

Maximal permissible clock frequency for reading the extended synchronous serial interface.

Timeout

Refers to the time after which communication is terminated by the encoder, when the master is no longer transmitting a clock rate.

Optical Encoders

Technical Information

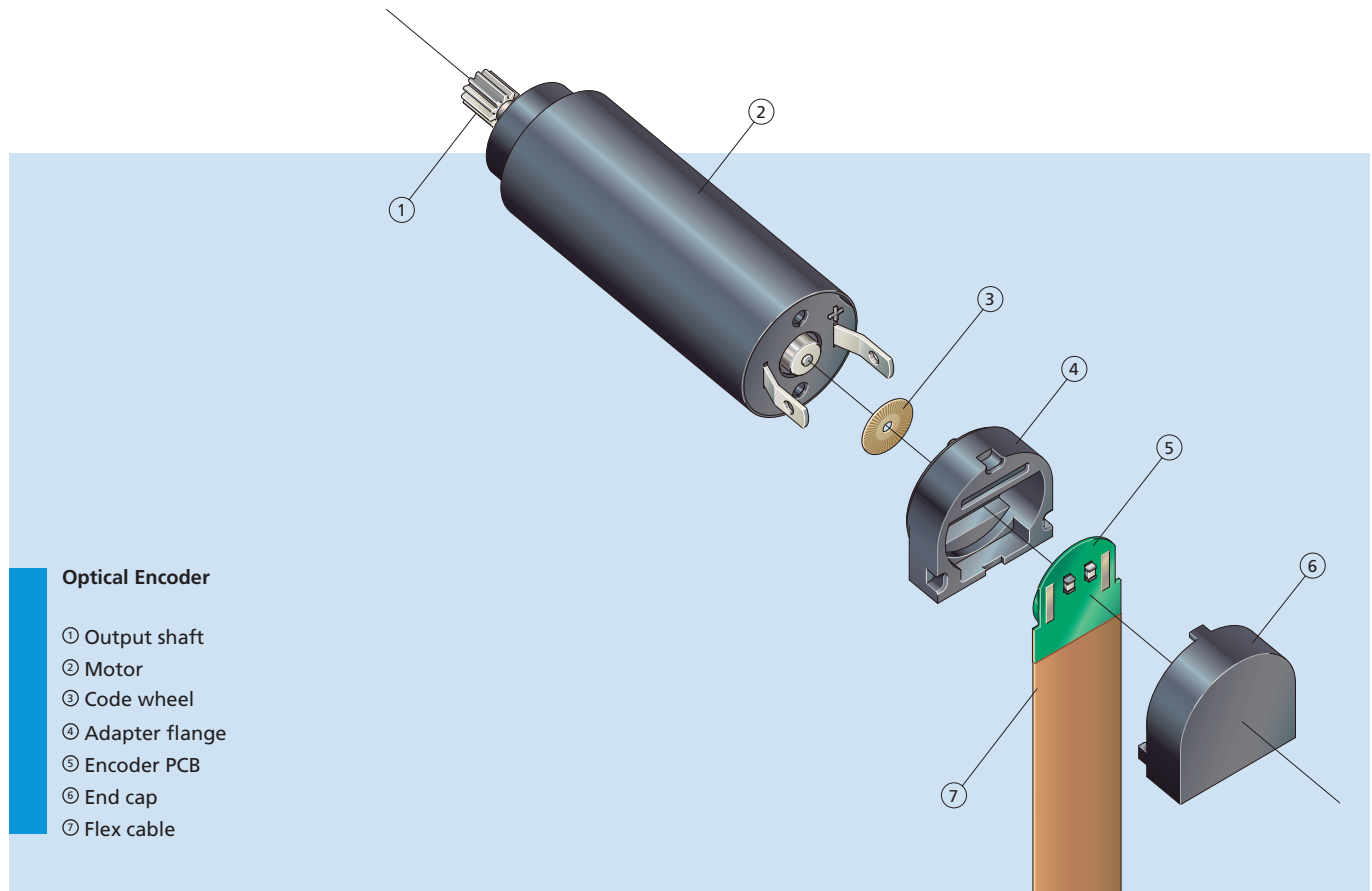

Optical Encoder

- ① Output shaft
- ② Motor
- ③ Code wheel
- ④ Adapter flange
- ⑤ Encoder PCB
- ⑥ End cap
- ⑦ Flex cable

Features

Optical encoders use a continuous infrared light source transmitting through a low-inertia multi-section rotor disk which is fitted directly on the motor rear end shaft. The unit thus generates two output signals with a 90° phase shift.

In optoreflexive encoders, the light source is sent and reflected back or alternately absorbed to create the necessary phase shifted pulse.

Benefits

- Very low current consumption
- Precise signal resolution
- Ideal for low voltage battery operation
- Insensitive to magnetic interference
- Extremely light and compact

Product Code



PA	Encoder series
2	Number of Channels
50	Resolution

PA2 - 50

Integrated Encoders

Technical Information

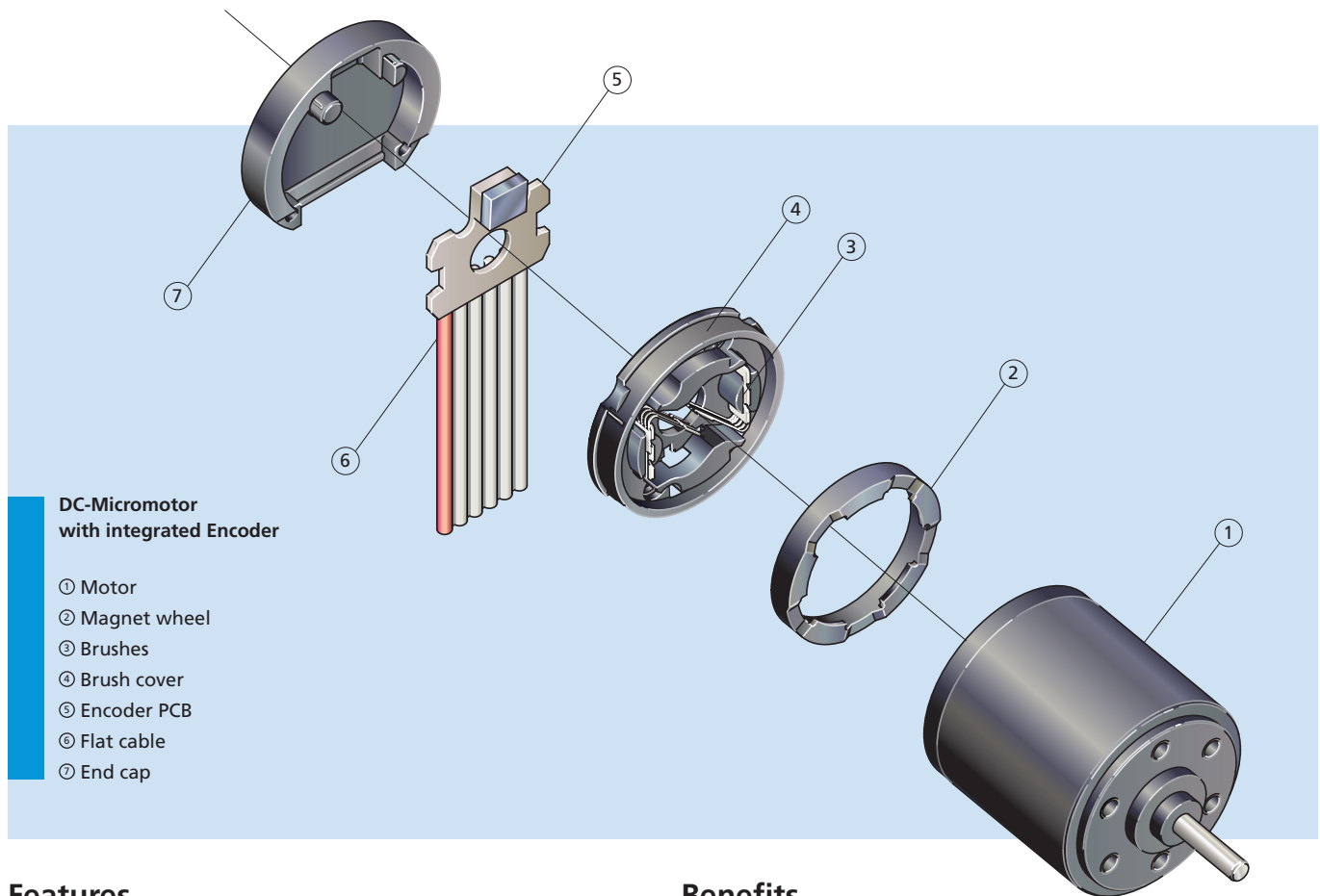

Features

The encoders of the IEH2 / IEH3 series consist of a multi-part magnetic ring, which is attached to the rotor, and a single-chip angle sensor. The angle sensor comprises all necessary functions, such as Hall sensors, an interpolator and driver stages. Analogue signals of the sensor magnets are detected by the Hall sensors and, after suitable amplification, passed along to the interpolator. By means of a special processing algorithm, the interpolator generates the high-resolution encoder signal. With this, two square wave signals that are phase-shifted by 90°, with up to 4096 pulses per rotation plus 1 additional index channel, are available at the outputs. The encoder is integrated in the motors of the SR series and lengthens these by just 1.4 mm.

Benefits

- Extremely compact
- High resolution of up to 16,384 steps per rotation (corresponds to a 0.02° angle resolution)
- No pull-up resistors are necessary at the outputs because there are no open collector outputs
- Symmetric switching edges, CMOS and TTL-compatible
- Different resolutions, according to type, from 16 to 4096 pulses, are available for standard delivery
- Installation space-compatible with IE2-1024

Product Code



IEH Incremental Encoder
2 Number of Channels
4096 Resolution

IEH2 - 4096

Magnetic Encoders

Single Chip

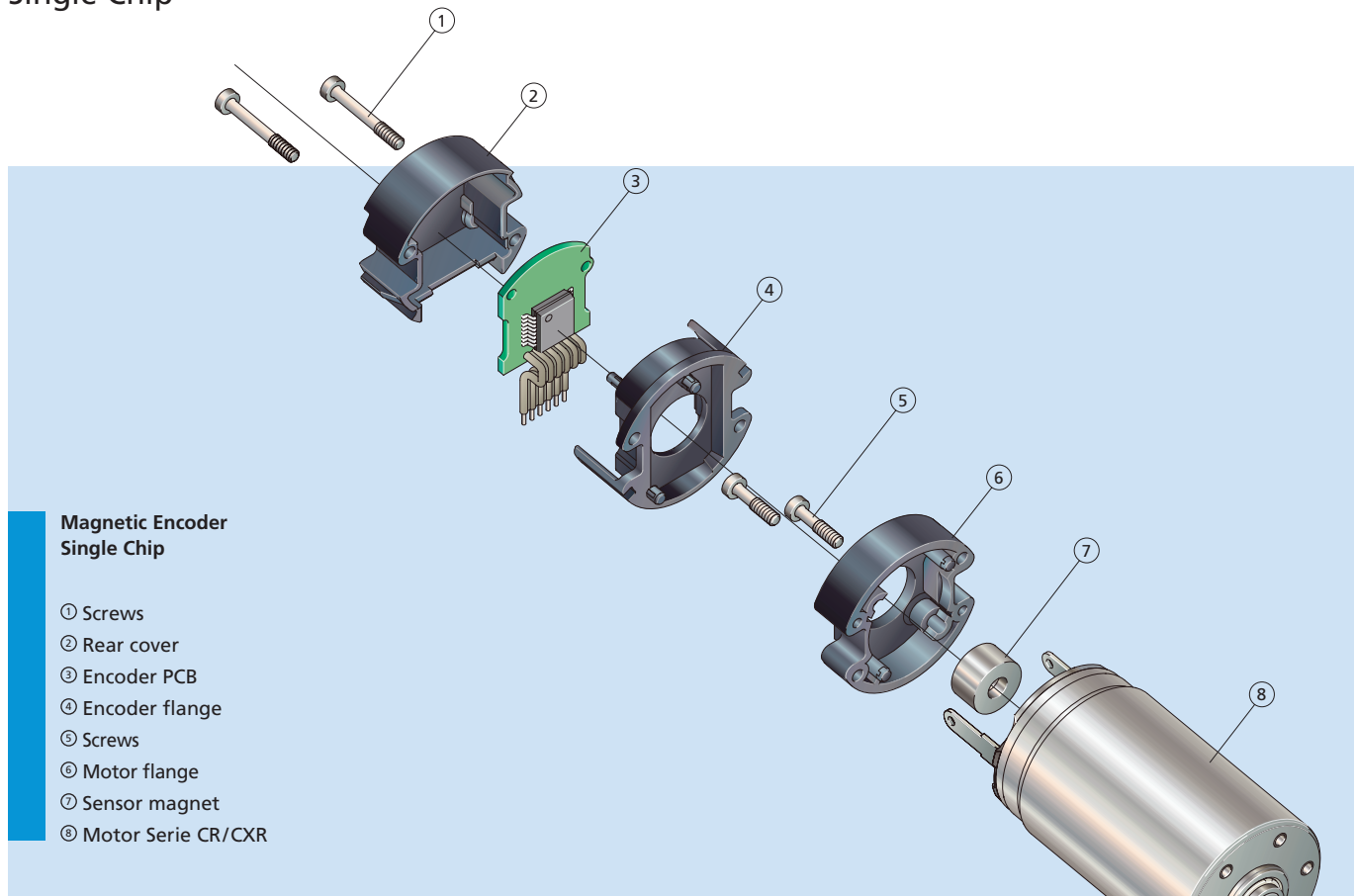

Features

FAULHABER IE3 encoders are designed with a diametrically magnetized code wheel which is pressed onto the motor shaft and provides the axial magnetic field to the encoder electronics. The electronics contain all the necessary functions of an encoder including Hall sensors, interpolation, and driver. The Hall sensors sensed the rotational position of the sensor magnet and the signal is interpolated to provide a high resolution position signal.

The encoder signal is a two channel quadrature output with a 90 °e phase shift between channels. A third channel provides a single index pulse per revolution. These encoders are available as attachable kits or preassembled to FAULHABER DC-Motors with graphite commutation, or as integrated assemblies for many FAULHABER Brushless DC-Servomotors.

Benefits

- Compact modular system
- A wide range of resolutions are available
- Index channel
- Line Drivers are available
- Standardized encoder outputs
- Ideal for combination with FAULHABER Motion Controllers and Speed Controllers
- Custom modifications including custom resolution, index position and index pulse width are possible

Product Code



IE	Incremental Encoder
3	Number of Channels
1024	Resolution
L	with integrated Line Driver

IE3 - 1024 L

Encoders Absolute

Single Chip

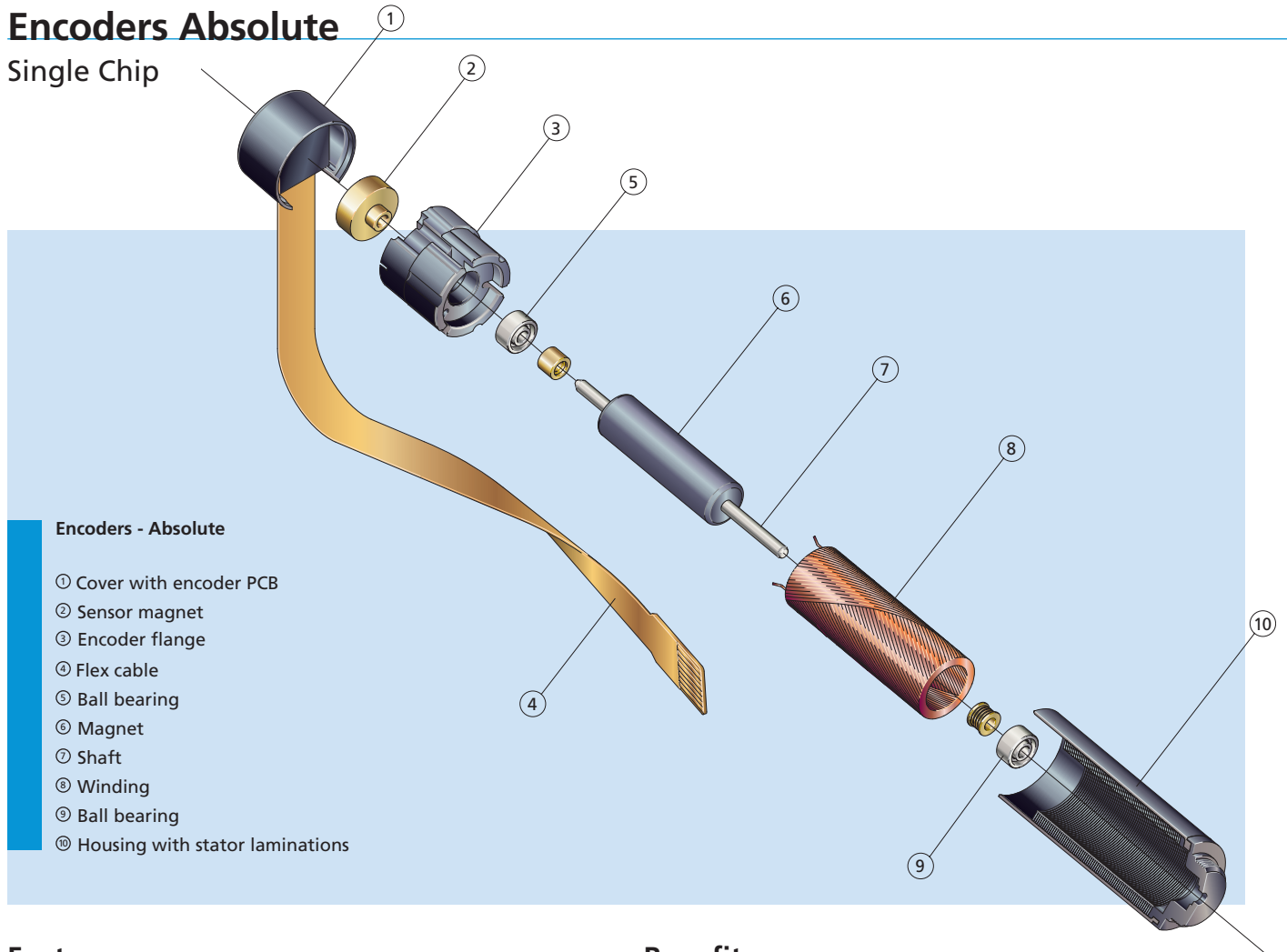

Encoders - Absolute

- ① Cover with encoder PCB
- ② Sensor magnet
- ③ Encoder flange
- ④ Flex cable
- ⑤ Ball bearing
- ⑥ Magnet
- ⑦ Shaft
- ⑧ Winding
- ⑨ Ball bearing
- ⑩ Housing with stator laminations

Features

Encoders in the AES series consist of a diametrically magnetized 2-pole sensor magnet mounted on the motor shaft. A special single-chip angle sensor for detecting the drive shaft position is positioned in an axial direction in relation to the sensor magnet. The angle sensor contains all the necessary functions such as Hall sensors, interpolator and driver stages. The analog signal of the sensor magnet detected by the Hall sensors is processed, after appropriate amplification, by a special algorithm to produce a high-resolution encoder signal. At the output there is absolute angle information available with a resolution of 4096 steps per revolution. This data can be scanned by an extended serial interface (SSI). The absolute encoder is ideal for commutation, rotational speed control and position control.

Benefits

- Minimal wiring
- Absolute angle information directly after power-on
- No referencing necessary
- Enhanced control characteristics even at low rotational speeds
- Ideal for combination with FAULHABER Motion Controllers and FAULHABER Speed Controllers
- Flexible customization of resolution and direction of rotation is possible

Product Code



AESM	Encoder Series
4096	Steps per revolution

AESM - 4096

Drive Electronics

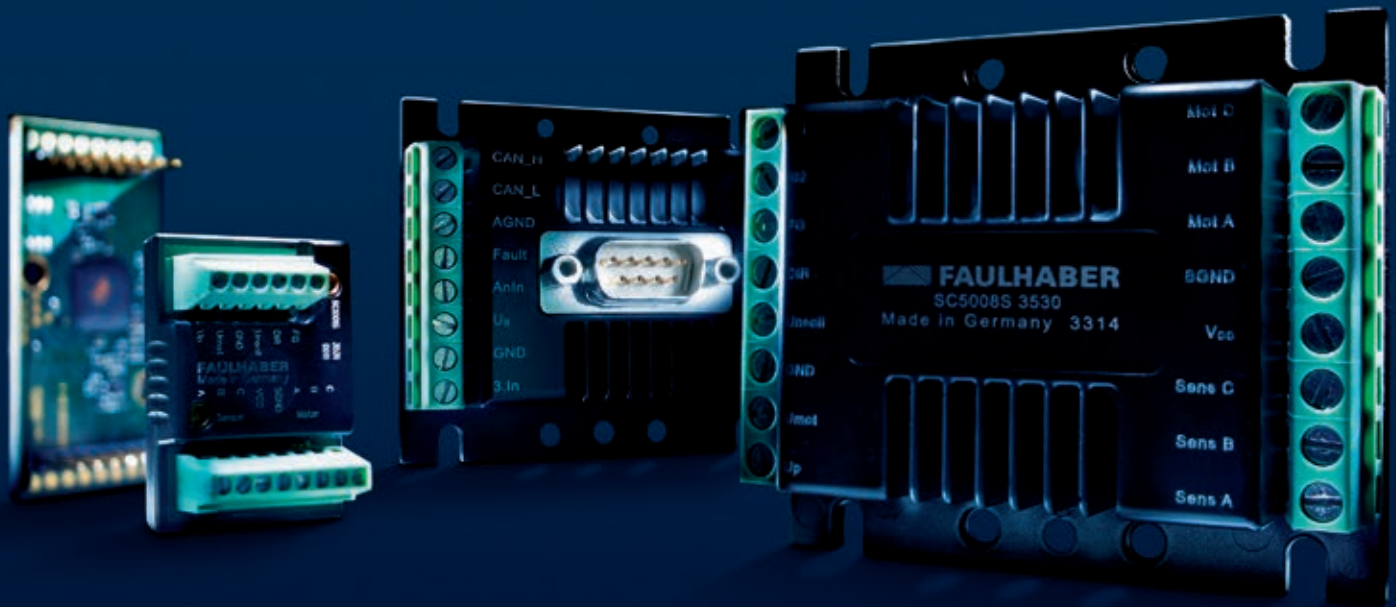

Speed Controller

Technical Information

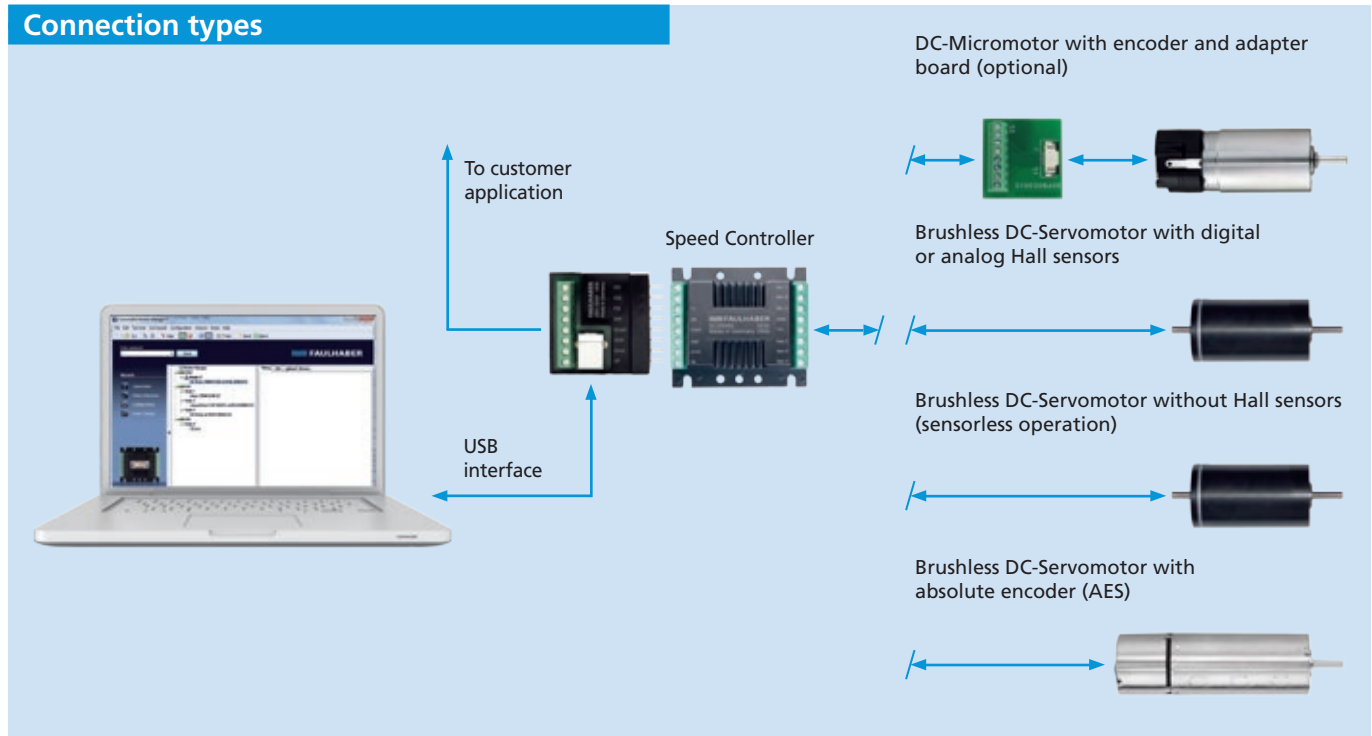

Function

FAULHABER Speed Controllers are highly dynamic speed governors that are optimized for the operation of micro-motors.

The Speed Controllers are available as separate controllers for

- DC-Micromotors
- Brushless DC-Servomotors.

The minimal wiring requirement and compact design of the Speed Controllers allow them to be used in a wide range of applications. The flexible interfacing options make them suitable for a variety of uses in all areas, e.g. in distributed automation systems, handling and tooling devices or pumps.

Benefits

- Compact design
- Flexible reconfiguration capacity
- Minimal wiring required
- Parameter setting using FAULHABER Motion Manager software and USB interface adapter
- Wide range of accessories

Product code

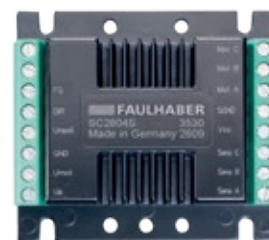

SC	Speed Controller
28	Max. supply voltage (28V)
04	Max. continuous output current (4A)
S	Housing with screw terminal
3530	Operating mode (brushless motor with digital Hall sensors)

SC_28_04_S_3530

Speed Controller

Description & Operating Modes

Description

Covering almost the entire range of FAULHABER GROUP motors, Faulhaber Speed Controllers are suitable for both Brushless DC-Servomotors (BL motors) and DC-Micromotors (DC motors).

- The Speed Controllers are extremely versatile and can be configured as required using a programming adapter and FAULHABER Motion Manager software.
- Depending on configuration, either a BL motor or DC motor can be run with the appropriate sensors for rotational speed measurement.
- The Speed Controllers are designed as velocity regulators. Control is via a PI controller.
- Sensorless operation, in which the rotational speed is determined by evaluating the counter-EMF (also known as back electromotive force), is also available.
- All Speed Controllers have a current limiter that limits the maximum motor current in the event of excessive thermal loads. In the standard configuration this current limiter is set to the maximum admissible value for the respective Speed Controller.

Standard models

To allow fast setup without programming adapter and software, the Speed Controllers come in various standard models. The variants specified for each type of controller can be reconfigured as required.

Operating modes

Depending on the type of controller, the Speed Controllers can be reconfigured to some or all of the following operating modes (cf. „Note“ below) using a programming adapter and FAULHABER Motion Manager software.

BL motors with digital or analog Hall sensors

In this configuration, the motors are operated with speed control, using the signals from the Hall sensors to commute and determine the actual speed.

BL motors without Hall sensors (sensorless operation)

Instead of applying Hall sensors, this configuration uses the counter-EMF of the motor for commutation and speed control.

BL motors with absolute encoder

This mode can only be used in conjunction with the relevant hardware. In this configuration the encoder provides absolute position data, which is used for commutation and speed control. Thanks to the encoder signal's high resolution, low rotational speeds can be achieved in this operating mode.

BL motors with digital Hall sensors and brake/enable input

In this configuration the motors are operated with speed control. Thanks to the additional brake/enable inputs, it is easier to connect the controller – e.g. to a PLC or fail-safe circuits.

BL motors with digital Hall sensors and encoder

In this configuration the Hall sensors provide the information for the commutation. The speed is adjusted to the signal from the incremental encoder. This is why a high resolution encoder is able to achieve very low speeds.

DC motors with encoder

In this configuration the motors are operated with speed control. An incremental encoder is necessary to transmit the actual rpm value.

DC motors without encoder

In the sensorless DC motor configuration the motors are operated with speed control using either the counter-electromotive force or an IxR compensation to register the actual rotational speed, depending on load. This operating mode has to be matched to the motor type.

In addition, other parameters can be modified using the **FAULHABER Motion Manager software**:

- Controller parameters
- Output current limitation
- Fixed rotational speed
- Encoder resolution
- Rpm setpoint via analog or PWM signal
- Maximum rotational speed or speed range

Note

Device manuals for installation and putting into operation and the „FAULHABER Motion Manager“ software are available on request and on the Internet at www.faulhaber.com. Please note that not all Speed Controllers are suitable for all operating modes. Detailed information on the various operating modes is provided in the respective data sheets.

Motion Controller

Technical Information

Connection options

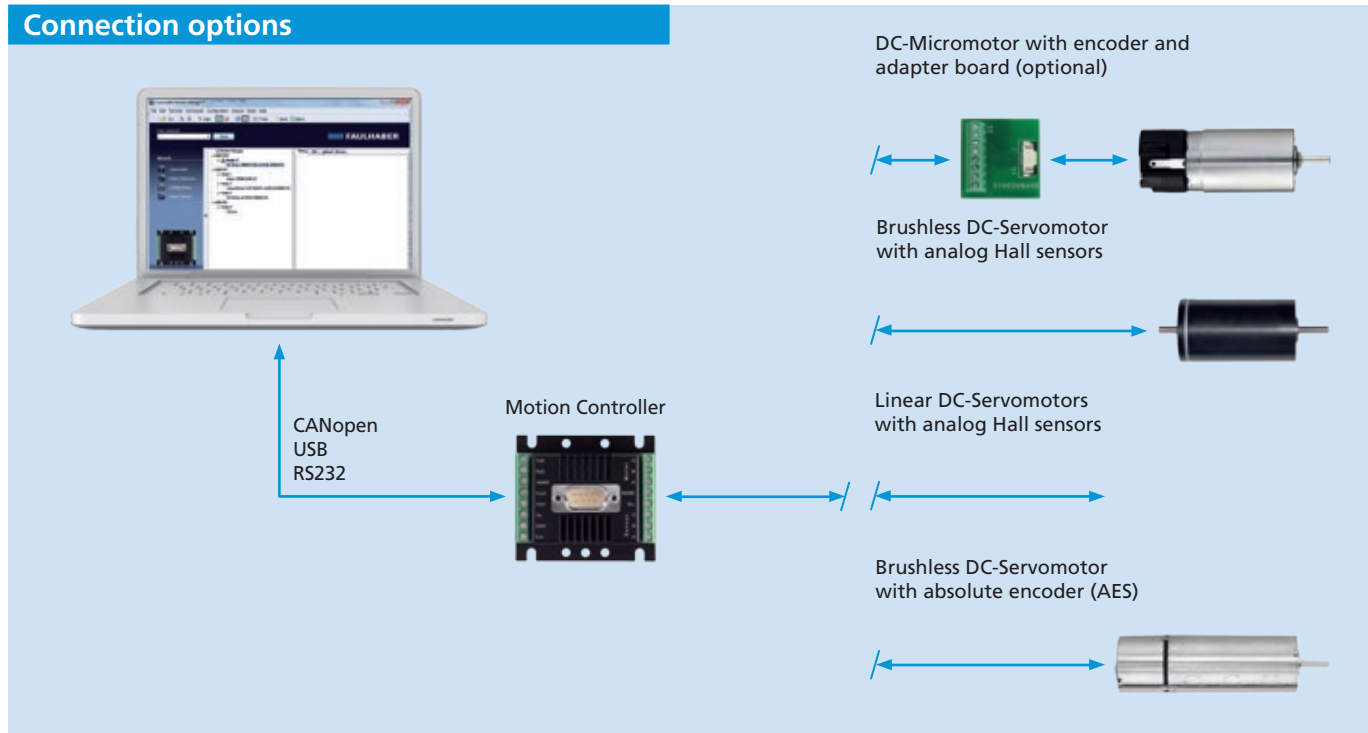

Features

FAULHABER Motion Controllers are highly dynamic positioning systems tailored specifically to the requirements of micromotor operations.

In addition to being deployed as a positioning system, they can also operate as speed or current controllers.

The Motion Controllers are available as separate controllers for:

- DC-Micromotors (MCDC)
- Brushless DC-Servomotors (MCBL)
- Linear DC-Servomotors (MCLM)

Motion Control Systems – highly dynamic, low-maintenance BLDC servomotors with integrated motion controls – deliver the ultimate in slimline design. The integrated systems require less space, as well as making installation much simpler thanks to their reduced wiring.

Benefits

- Compact construction
- Controlled via RS232 or CAN interface
- Minimal wiring
- Parametrization with „FAULHABER Motion Manager“ software and USB interface
- Extensive accessories

Product Code

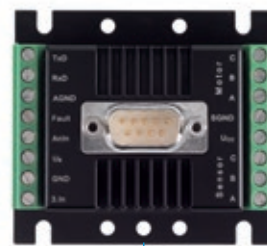

MC	Motion Controller
BL	For Brushless DC-Motors
30	Max. supply voltage (30 V)
06	Max. continuous output current (6 A)
S	Housing with screw terminal
AES	Only for BLDC-Motors with absolute encoders
CF	CAN interface, FAULHABER CAN

MC BL 30 06 S AES CF

Motion Controller

Configuration, Networking, Interfaces

Operating Modes

Speed control

PI speed controls, even for demanding synchronization requirements

Positioning

For moving to defined positions with a high level of resolution. Using a PD Controller, the dynamic response can be adjusted to suit the application. Reference and limit switches are evaluated by means of various homing modes.

Speed profiles

Acceleration ramps, deceleration ramps and maximum velocity can also be defined for each section. As a result, even complex profiles can be implemented quickly and effectively.

Current control

Protects the drive by limiting the motor current to the set peak current. The current is limited to the continuous current by means of integrated I²t monitoring if required.

Protective features

- Protection against ESD
- Overload protection for electronics and motor
- Self-protection from overheating
- Overvoltage protection in generator mode

Extended operating modes

- Stepper motor mode
- Gearing mode
- Position control to analog set point
- Operation as servo amplifier in voltage adjuster mode
- Torque/force controller using variable set current input

Options

Separate supply of power to the motor and electronic actuator is optional (important for safety-critical applications). Third Input is not available with this option. Depending on the controller, additional programming adapters and connection aids are available. The modes and parameters can be specially pre-configured on request.

Interfaces - Discrete I/O

Setpoint input

Depending on the operating mode, setpoints can be input via the command interface, via an analog voltage value, a PWM signal or a quadrature signal.

Error output (Open Collector)

Configured as error output (factory setting). Also usable as digital input, free switch output, for speed control or signaling an achieved position.

Additional digital inputs

For evaluating reference switches.

Interfaces - Position Sensor

Depending on the model, one of the listed interfaces for the position and speed sensor is supported.

Analog Hall signals

Three analog Hall signals, offset by 120°, in Brushless DC-Motors and Linear DC-Servomotors.

Incremental encoders

In DC-Micromotors and as additional sensors for Brushless DC-Motors.

Absolute encoders

Serial SSI port, matching Brushless DC-Servomotors with AES encoders

Networking

FAULHABER Motion Controllers are available with three different interfaces.

RS: This indicates a system with an RS232 interface. It is ideal for applications that do not use a higher level controller. Operation is made simple through the use of a plain text command set which can be used to generate scripts and programs that can run autonomously on the controller itself.

CF: This indicates a system with a FAULHABER CAN interface. This version contains the CiA 402 commands and includes the RS232 interface commands which are translated into simple to use CAN commands. This version is intended as a user friendly, simple to use bridge into to the complex use of CAN communications. A CAN master is always required when using this version.

CO: This indicates a system with a CANopen interface. This version is ideal when integrating a FAULHABER motion controller into a system with a PLC, either directly or through the use of a gateway. All parameter settings are made via the object directory. Configuration is possible through the use of the FAULHABER Motion Manager 5.0 or better, or standard CAN configuration tools.

Motion Controller

Configuration, Networking, Interfaces

Interfaces – Bus Connection

Version with RS232

For coupling to a PC with a transfer rate of up to 115 kbaud. Multiple drives can be connected to a single controller using the RS232 interface. As regards the control computer, no special arrangements are necessary. The interface also offers the possibility of retrieving online operational data and values.

A comprehensive ASCII command set is available for programming and operation. This can be preset from the PC using the „FAULHABER Motion Manager“ software or from another control computer.

Additionally, there is the possibility of creating complex processes from these commands and storing them on the drive. Once programmed as a speed or positioning controller via the analog input, as step motor or electronic gear unit, the drive can operate independently of the RS232 interface.

Versions with CAN CF or CO

Two controller versions with a CANopen interface are available for optimal integration within a wide range of applications. CANopen is the perfect choice for networking miniature drives because the interface can also be integrated into small electronics. Due to their compact size and efficient communication methods, they are the ideal solution for complex fields of application such as industrial automation.

CF version: CANopen with FAULHABER channel

The CF version supports not only CiA 402 standard operating modes but also a special FAULHABER Mode. Via PDO2, operator control is thus analogous to that of the RS232 version. Extended operating modes such as operation with analog setpoint input or the stepper or gearing mode are also supported. The CF version is therefore particularly suitable for users who are already familiar with the RS232 version and wish to exploit the benefits of CAN in networking.

CO version: pure CANopen

The CO version provides the CiA 402 standard operating modes. All the parameters are directly stored in the object directory. Configuration can therefore be performed with the help of the FAULHABER Motion Manager or by applying available standardized configurators tools common to the automation market. The CO version is particularly suitable for users who already use various CANopen devices or operate the Motion Controllers on a PLC. With dynamic PDO mapping it is possible to achieve highly efficient networking on the CAN.

CF / CO comparison

	CF	CO
NMT with node guarding	•	•
Baud rate	1 Mbit max., LSS	1 Mbit max, LSS
EMCY object	•	•
SYNCH Objekt	•	•
Server SDO	1x	1x
PDOs	3 x Rx 3 x Tx each with static mapping	4 x Rx 4 x Tx each with dynamic mapping
PDO ID	fixed	adjustable
Configuration	Motion Manager	Motion Manager from V5
Trace	PDO3 (fixed)	Any PDO
Standard operating modes	•	•
- Profile Position Mode - Profile Velocity Mode - Homing		
Ext. operating modes	FAULHABER channel	-

Both versions support the CANopen communication profile to CiA 301 V4.02. The transfer rate and node number are set via the network in accordance with the LSS protocol conforming to CiA 305 V1.11.

For this purpose, we recommend using the latest version of the FAULHABER Motion Manager.

Notes

Device manuals for installation and start up, communication and function manuals, and the „FAULHABER Motion Manager“ software are available on request and on the Internet at www.faulhaber.com.

Motion Controller Software

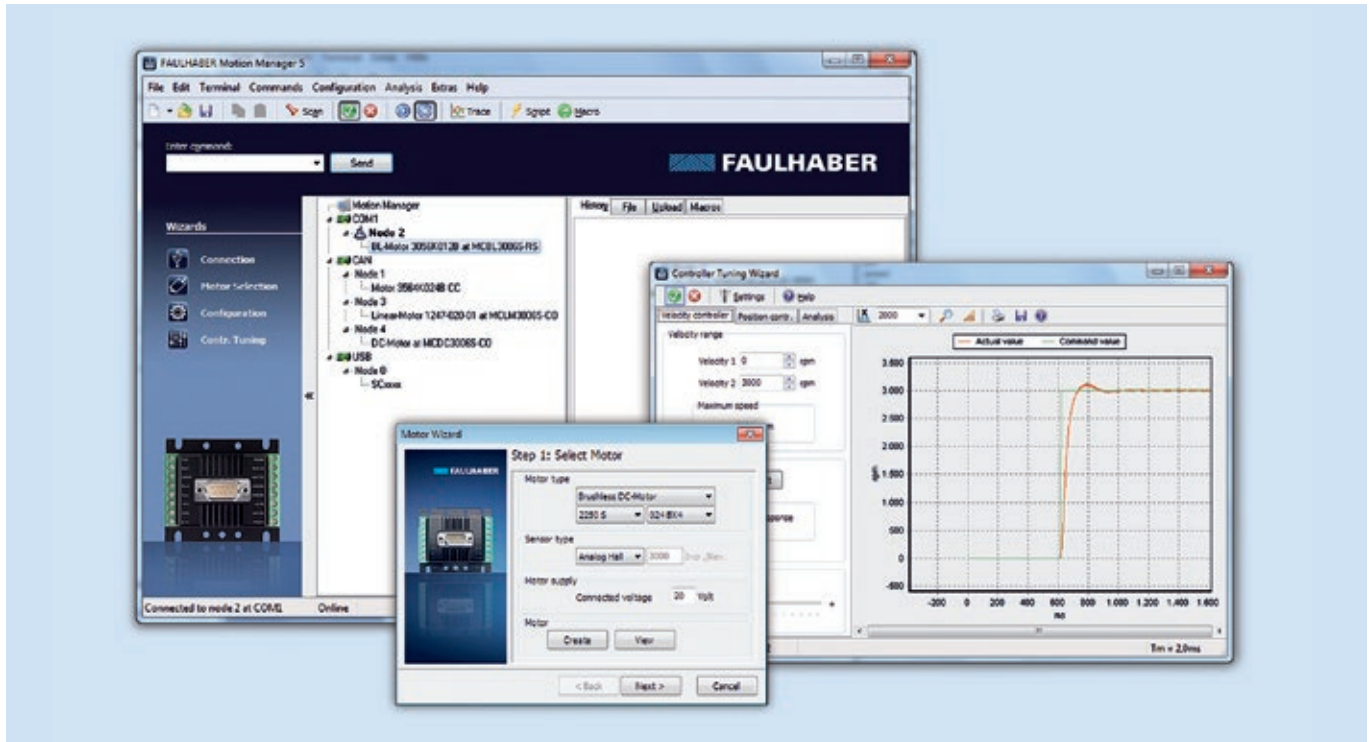

Motion Manager

The high-performance software solution „FAULHABER Motion Manager“ enables users to control and configure drive systems with Speed- and Motion Controllers.

The RS232, USB and CAN interfaces are supported. All the interface versions can be operated in a standardized manner via a graphical user interface. This also represents a user-friendly introduction to CAN technology, especially when using the CANopen Motion Controllers with FAULHABER-CAN (CF version).

„FAULHABER Motion Manager“ for Microsoft Windows can be downloaded free of charge from www.faulhaber.com.

Startup and Configuration

The software provides convenient access to the settings and parameters of connected motor controls.

The graphical user interface can be used to read out, change and reload configurations. Individual commands or complete parameter sets and program sequences can be entered and transferred to the control.

In addition, analysis options are available in the form of status displays and graphic trace windows.

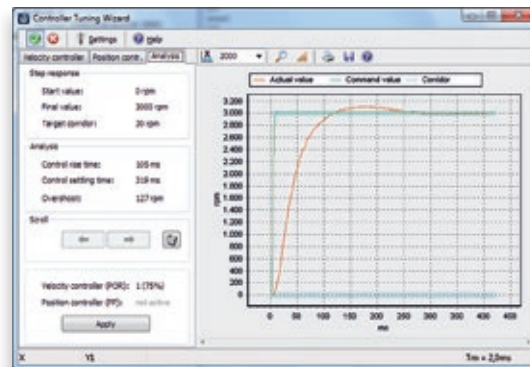

Operation of drives is also supported by a

- connection wizard
- motor selection wizard
- configuration wizard
- controller tuning wizard

The program also includes an Online Help and the integrated Visual Basic Script language.

More information



faulhaber.com



[faulhaber.com/facebook](https://www.facebook.com/faulhaber.com)



[faulhaber.com/youtubeEN](https://www.youtube.com/faulhaber.com)



[faulhaber.com/linkedin](https://www.linkedin.com/company/faulhaber.com)



[faulhaber.com/instagram](https://www.instagram.com/faulhaber.com)