

NB: Pinza e ghiera vengono fornite a richiesta.
 NB: Collet and ring nut only on your request.

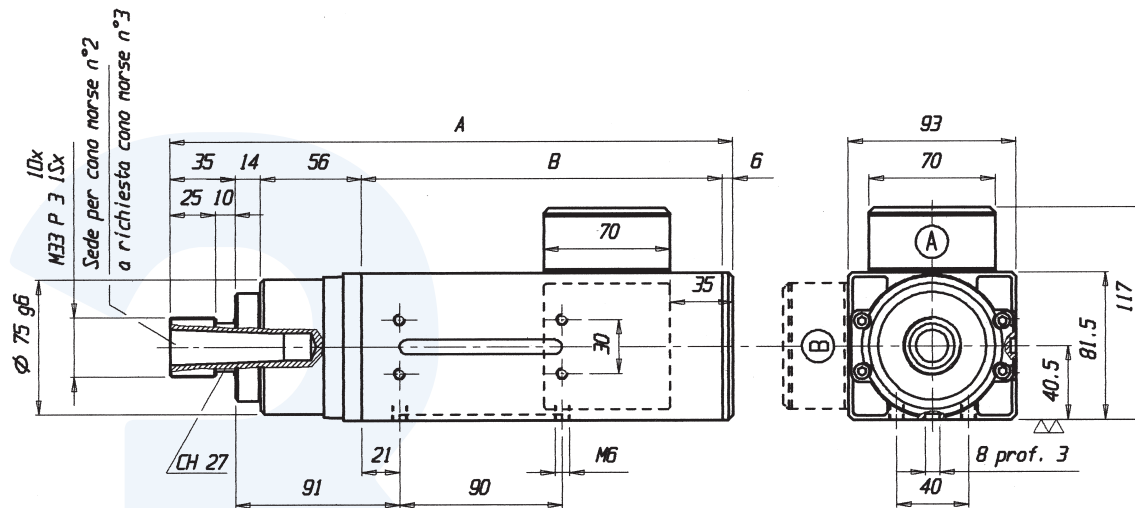

Sporgenza per pinza ER 25
 Nose type for collet ER 25

Tipo/Type	A	B
TMPE3 9/2	311	200
TMPE3 12/2	351	240



NB: Posizione morsetti standard come da posizione "A" con forature lato largo. Su richiesta in posizione "B" con forature lato stretto.
 NB: Standard terminal box in "A" position with fixing holes on wide part. On request terminal box in "B" position with fixing holes on narrow part.



Sporgenza per cono morse 2-3
 Nose type for MK 2-3

Tipo/Type	A	B
TMPE3 9/2	311	200
TMPE3 12/2	351	240

dimensioni