

GRAND-TOURING 500 '97
GRAND-TOURING 583 '97

LOCATION OF CONNECTORS

- C-1, C-2, C-3, C-3A, C-4 NEAR ENGINE
- C-5 : NEAR REGULATOR UNDER ENGINE
- C-6, C-6A, BETWEEN SEAT AND FUEL TANK
- C-7 : ON THE LUGGAGE RACK
- C-8 : UNDER OIL INJECTION RESERVOIR
- C-9 : JUNCTION BETWEEN HOOD AND FRAME
- C-10 @ C-17 : IN HOOD, NEAR INSTRUMENT LOCATION
- C-18 @ C-24 : NEAR STEERING COLUMN
- C-25 : ABOVE CHAINCASE
- C-26 : ON IGNITION SWITCH

WARNING

- ENSURE ALL TERMINALS ARE PROPERLY CRIMPED ON THE WIRES AND ALL CONNECTOR HOUSINGS ARE PROPERLY FASTENED

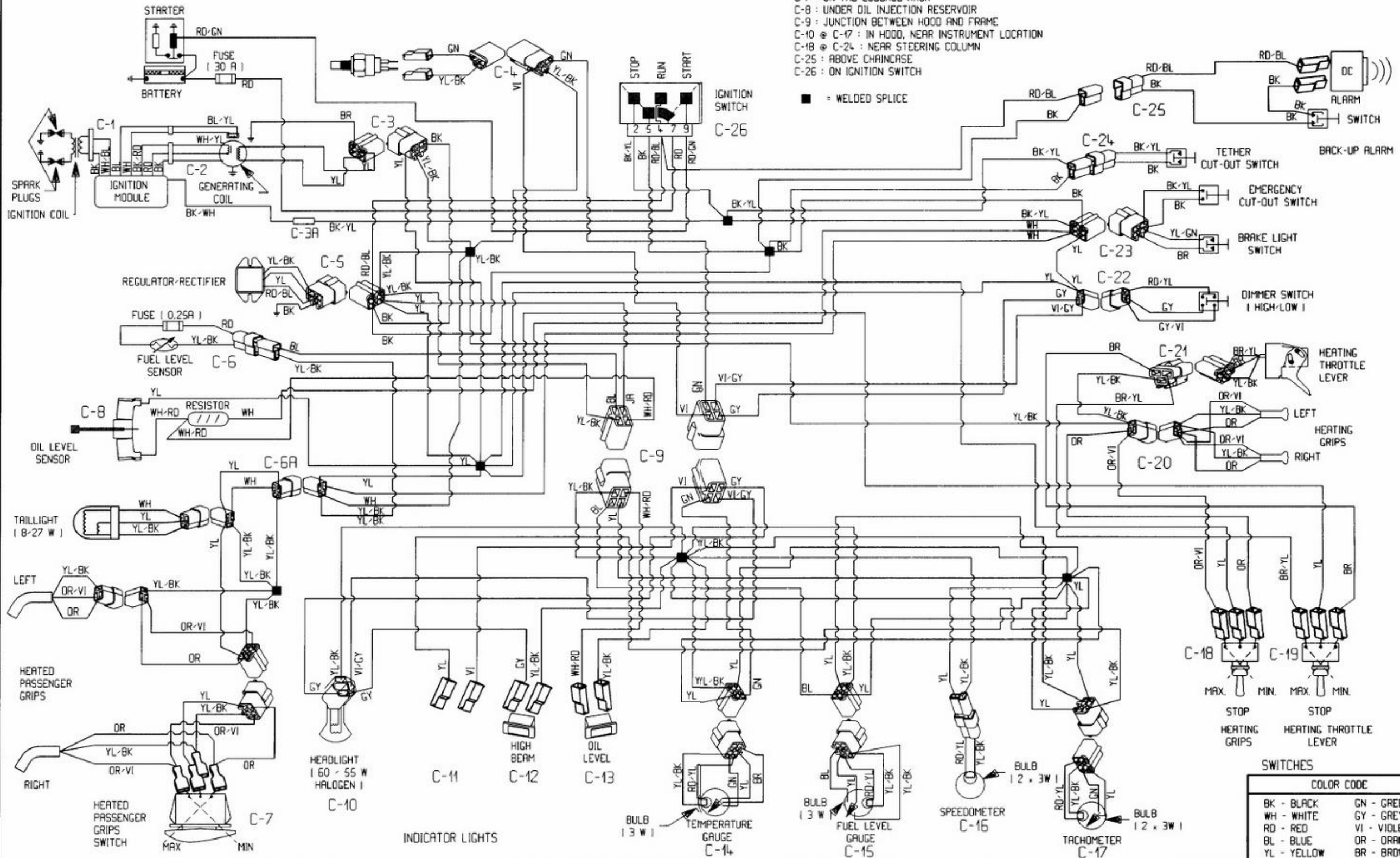

■ = WELDED SPLICE

SWITCHES

COLOR CODE	
BK - BLACK	GN - GREEN
WH - WHITE	GY - GREY
RD - RED	VI - VIOLET
BL - BLUE	OR - ORANGE
YL - YELLOW	BR - BROWN